



GC24003 Shown
FTA Style

Applications: General purpose fixed speed including conveyors, material handling equipment and packaging machinery.

Features: PSC motor design providing 100% starting torque. High strength bronze gearing, hardened and ground worm for quiet operation. High performance low friction, bidirectional motor seals. Factory lubricated with synthetic grease, no routine maintenance is required. Can be mounted in all positions including vertical motor below gearbox.

Input Motor Hp	Output RPM 50/60 Hz	Gear Ratio	Max. Safe Torque In. Lbs.	Catalog Number	List Price	Mult. Sym.	Ap'x. Shpg. Wgt.	Motor Type & Gear Style	Enclosure	Voltage	Notes ^(b)
Single Phase											
1/50	59/71.4	24:1	7.5	GC24003	406	DS	7	2412C-FTA	TENV	115	19,20

^(b) See notes on inside back flap.

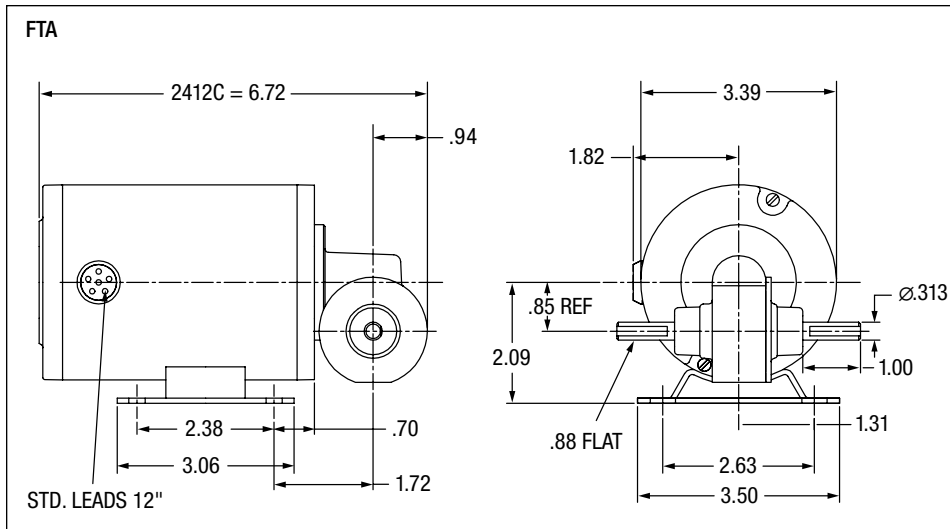



Applications: General purpose fixed speed including conveyors, material handling equipment and packaging machinery.

Features: Three and single-phase motor designs. High strength bronze gearing, hardened and ground worm for quiet operation. High performance low friction, bidirectional motor seals. Factory lubricated for life, no routine maintenance is required. Internal oil expansion bladder allows for multiple mounting positions, without relocating a breather vent.

Input Motor Hp	Output RPM 50/60 Hz	Gear Ratio	Max. Safe Torque In. Lbs.	Catalog (a) Number	List Price	Mult. Sym.	Ap'x. Shpg. Wgt.	Motor Type & Gear Style	Enclosure	Voltage	Notes (b)	Drawing Number
Single Phase												
1/20	35/42	40:1	30	GC24310	503	DS	10	2416C-BB	TENV	115	19,20,78	1
	68/82.7	20:1	24	GC24306	503	DS	10	2416C-BB	TENV	115	19,20,78	1
	133/160	10:1	14	GC24302	503	DS	10	2416C-BB	TENV	115	19,20,78	1
Three Phase												
1/12	95/115	15:1	30	GM25026	542	DS	12	2516M-BA	TENV	190/380//230/460	19,20	2
1/8	143/174	10:1	30	GM25024	558	DS	13	2516M-BA	TENV	190/380//230/460	19,20	3
	285/345	5:1	15	GM25022	558	DS	13	2516M-BA	TENV	190/380//230/460	19,20	3
1/6	230	15:1	27	GM3329	703	DS	11	2512M-BA	TEFC	208-230/460	20,33	4

(a) Vertical motor below gearhead not recommended. Avoiding those positions where the high speed oil seal is immersed in oil, will provide greater security against high speed input seal wear.
 (b) See notes on inside back flap.

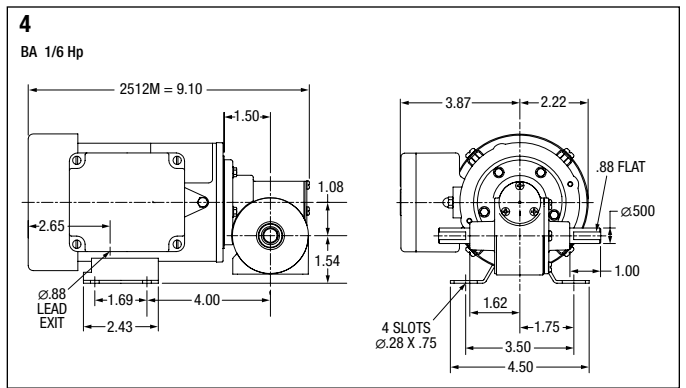
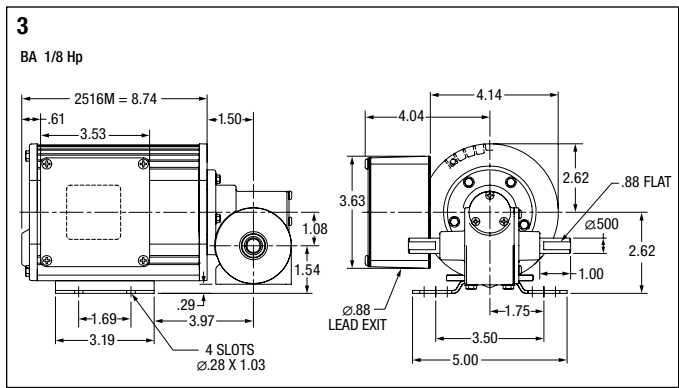
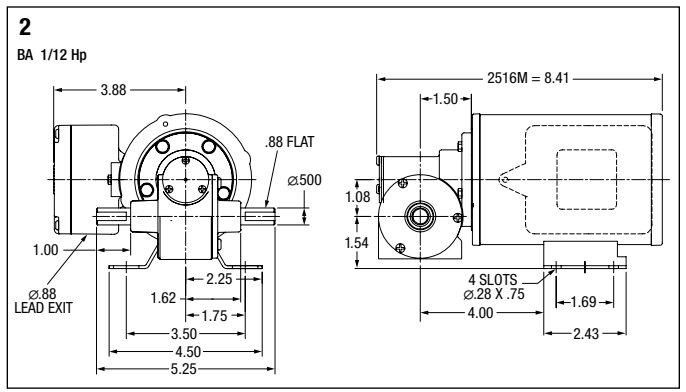
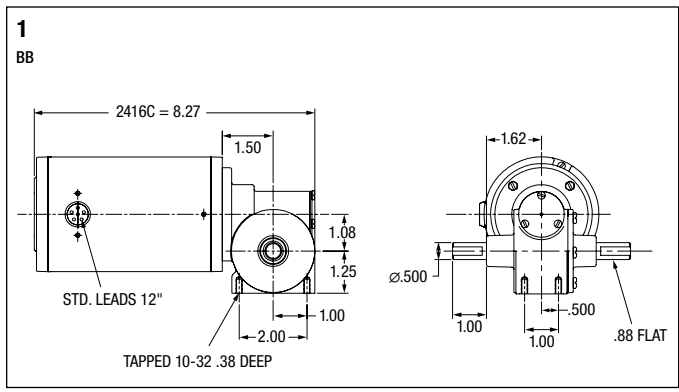



GC24208 Shown
DB Style

Applications: General purpose fixed speed including conveyors, material handling equipment and packaging machinery.

Features: PSC motor design provides 100% starting torque. High strength bronze gearing, hardened and ground worm for quiet operation. High performance low friction, bidirectional motor seals. Factory lubricated for life, no maintenance required. Internal oil expansion bladder allows for multiple mounting positions, without relocating a bladder vent.

Input Motor Hp	Output RPM 50/60 Hz	Gear Ratio	Max. Safe Torque In. Lbs.	Catalog Number ^(a)	List Price	Mult. Sym.	Ap'x. Shpg. Wgt.	Motor Type & Gear Style	Enclosure	Voltage	Notes ^(b)
Single Phase											
1/40	11.8/14	117:1	40	GC24208	540	DS	10	2412C-DB	TENV	115	19,20,78

^(a) Vertical motor below gearhead not recommended.

Avoiding those positions where the high speed oil seal is immersed in oil, will provide greater security against high speed input seal wear.

^(b) See notes on inside back flap.

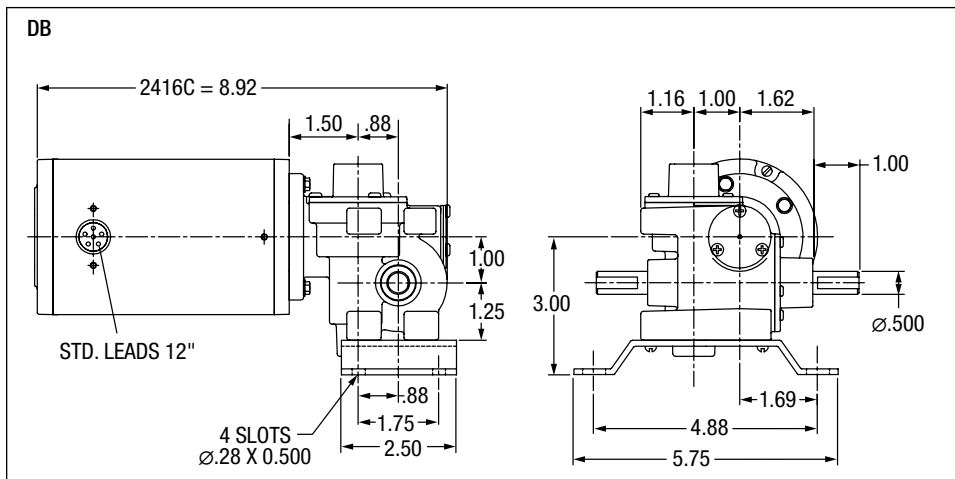



GC24314 Shown
EB Style

Applications: General purpose fixed speed including conveyors, material handling equipment and packaging machinery.

Features: Three and single-phase motor designs. High strength bronze gearing, hardened and ground worm for quiet operation. High performance low friction, bidirectional motor seals. Factory lubricated for life, no maintenance required. Internal oil expansion bladder allows for multiple mounting positions, without relocating a breather vent.

Input Motor Hp	Output RPM 50/60 Hz	Gear Ratio	Max. Safe Torque In. Lbs.	Catalog Number ^(a)	List Price	Mult. Sym.	Ap'x. Shpg. Wgt.	Motor Type & Gear Style	Enclosure	Voltage	Notes ^(b)	Drawing Number
Single Phase												
1/13	7.7/9.3	180:1	175	GC24314	690	DS	14	2416C-EB	TENV	115	19,20,78	1
1/20	12.7/16	100:1	100	GC24312	690	DS	12	2416C-EB	TENV	115	19,20,78	1
Three Phase												
1/12	1.5	1200:1	175	GM25021	730	DS	15	2516M-EB	TENV	208/230-460	20,33	2
	11.3	150:1	125	GM25016	730	DS	15	2516M-EB	TENV	208/230-460	20,33	2

(a) Vertical motor below gearhead not recommended.

Avoiding those positions where the high speed oil seal is immersed in oil, will provide greater security against high speed input seal wear.

(b) See notes on inside back flap.

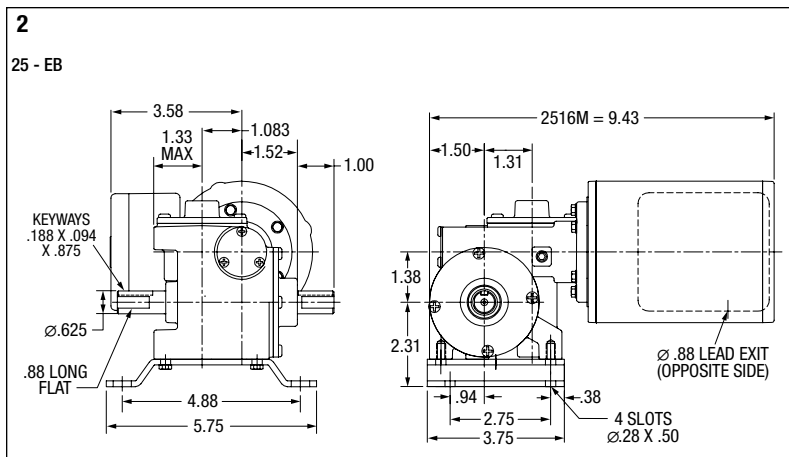
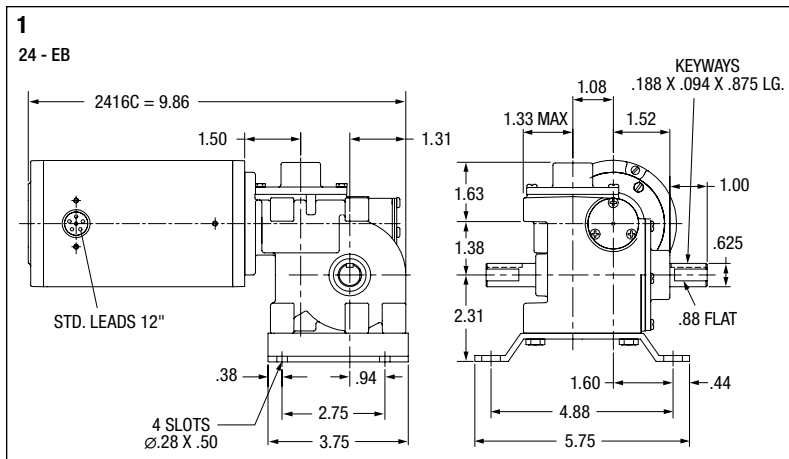



GC25280 Shown
G Style

Applications: General purpose fixed speed including conveyors, material handling equipment and packaging machinery.

Features: Three and single-phase motor designs. PSC, single-phase gearmotors supplied with capacitor and conduit box. High strength bronze, ground worm first-stage and helical output stage. High performance low friction, bidirectional motor seals. Factory lubricated for life, no maintenance required. Completely sealed from the environment.

Input Motor Hp	Output RPM 60 Hz	Gear Ratio	Max. Safe Torque In. Lbs.	Catalog (a) Number	List Price	Mult. Sym.	Ap'x. Shpg. Wgt.	Motor Type & Gear Style	Enclosure	Voltage	Notes (b)
Single Phase											
1/6	4.9/5.9	280:1	400	GC25280	881	DS	20	2520C-G	TEFC	115	19,20
	7.4/8.9	190:1	385	GC25190	881	DS	21	2520C-G	TEFC	115	19,20
	11.6/14	120:1	300	GC25120	881	DS	20	2520C-G	TEFC	115	19,20
	17.5/21	80:1	290	GC25080	881	DS	15	2520C-G	TEFC	115	19,20
	23/28	60:1	220	GC25060	881	DS	20	2520C-G	TEFC	115	19,20
Three Phase											
1/6	4.9/5.9	280:1	400	GM25280	959	DS	12	2516M-G	TEFC	190/380//230/460	19,20
	7.3/8.9	190:1	385	GM25190	959	DS	20	2516M-G	TEFC	190/380//230/460	19,20
	11.3/13.3	120:1	300	GM25120	959	DS	10	2516M-G	TEFC	190/380//230/460	19,20
	16.5/20.4	80:1	310	GM25080	959	DS	20	2516M-G	TEFC	190/380//230/460	19,20
	22.5/27.5	60:1	250	GM25060	959	DS	20	2516M-G	TEFC	190/380//230/460	19,20

(a) Vertical motor below gearhead not recommended.

Avoiding those positions where the high speed oil seal is immersed in oil, will provide greater security against high speed input seal wear.

(b) See notes on inside back flap.

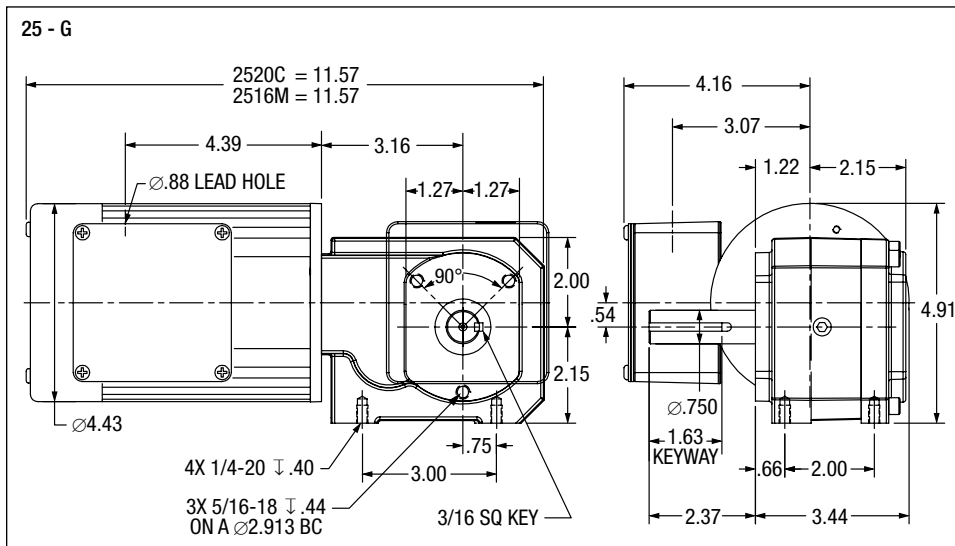



GC24307 Shown
KA Style

Applications: General purpose fixed speed including conveyors, material handling equipment and packaging machinery.

Features: Three and single-phase motor designs. High strength bronze gearing, hardened and ground worm for quiet operation. High performance low friction, bidirectional motor seals. Factory lubricated for life, no maintenance required. Internal oil expansion bladder allows for multiple mounting positions, without relocating a breather vent.

Input Motor Hp	Output RPM 50/60 Hz	Gear Ratio	Max. Safe Torque In. Lbs.	Catalog Number ^(a)	List Price	Mult. Sym.	Ap'x. Shpg. Wgt.	Motor Type & Gear Style	Enclosure	Voltage	Notes ^(b)	Drawing Number
Single Phase												
1/15	23/28	60:1	45	GC24307	537	DS	11	2416C-KA	TEFC	110//115	19,20	1
	35/42	40:1	49	GC24308	537	DS	11	2416C-KA	TEFC	110//115	19,20	1
	68/82.5	20:1	32	GC24309	537	DS	11	2416C-KA	TEFC	110//115	19,20	1
	135/165	10:1	18	GC24311	537	DS	11	2416C-KA	TEFC	110//115	19,20	1
1/8	34/41	40:1	90	GC25004	635	DS	16	2520C-KA	TEFC	110//115	19,20	2
	46/55	30:1	78	GC25006	635	DS	16	2520C-KA	TEFC	110//115	19,20	2
	69/82	20:1	57	GC25007	635	DS	16	2520C-KA	TEFC	110//115	19,20	2
	130/160	10:1	33	GC25008	635	DS	16	2520C-KA	TEFC	110//115	19,20	2
	36/43	40:1	90	GC25009	635	DS	17	2520S-KA	TEFC	110//115	19,20	2
	48/57	30:1	78	GC25011	635	DS	15	2520S-KA	TEFC	110//115	19,20	2
	71/86	20:1	57	GC25012	635	DS	15	2520S-KA	TEFC	110//115	19,20	2
	140/170	10:1	33	GC25014	635	DS	15	2520S-KA	TEFC	110//115	19,20	2
1/6	33/41	40:1	130	GC3320	701	DS	15	2524C-K	TEFC	110//115	19,20	3
	67/82	20:1	75	GC3321	701	DS	15	2524C-K	TEFC	110//115	19,20	3
	135/165	10:1	43	GC3322	701	DS	15	2524C-K	TEFC	110//115	19,20	3
	265/320	5:1	23	GC3324	701	DS	15	2524C-K	TEFC	110//115	19,20	3
	35/42	40:1	130	GC3326	701	DS	18	2528L-K	TEFC	110//115	19,20	4
	71/85	20:1	75	GC3327	701	DS	21	2528L-K	TEFC	110//115	19,20	4
	135/165	10:1	43	GC3328	701	DS	21	2528L-K	TEFC	110//115	19,20	4
280/335	5:1	23	GC3329	701	DS	18	2528L-K	TEFC	110//115	19,20	4	
Three Phase												
1/4	35/42.8	40:1	170	GM3340	848	DS	16	2524M-K	TEFC	190/380//230/460	19,20	3
	70/85	20:1	112	GM3345	848	DS	16	2524M-K	TEFC	190/380//230/460	19,20	3
	140/170	10:1	72	GM3347	848	DS	16	2524M-K	TEFC	190/380//230/460	19,20	3
	279/340	5:1	36	GM3349	848	DS	16	2524M-K	TEFC	190/380//230/460	19,20	3

(a) Vertical motor below gearhead not recommended. Avoiding those positions where the high speed oil seal is immersed in oil, will provide greater security against high speed input seal wear.
(b) See notes on inside back flap.

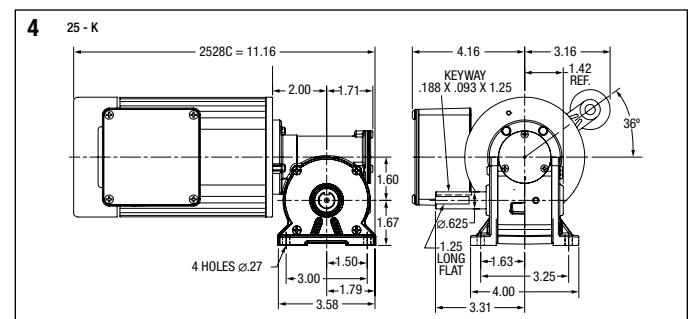
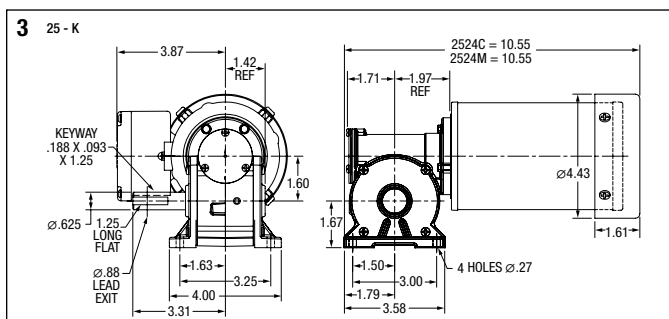
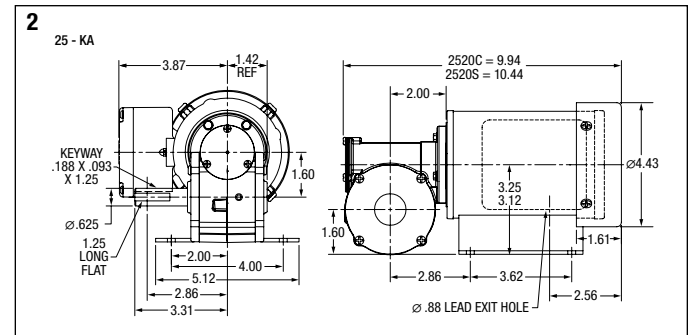
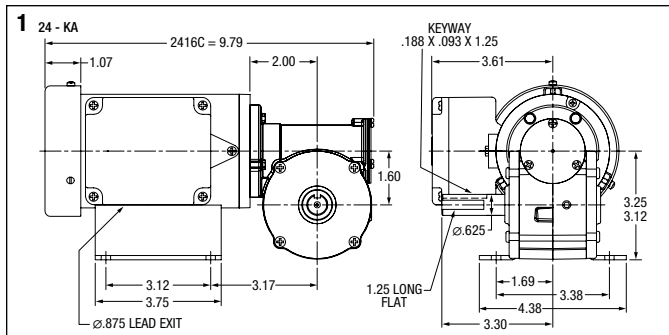



GC24322 Shown
CB Style

Applications: General purpose fixed speed including conveyors, material handling equipment and packaging machinery.

Features: Three and single-phase designs. High strength bronze gearing, hardened and ground worm for quiet operation. High performance low friction, bidirectional motor seals. Factory lubricated for life, no maintenance required. Internal oil expansion bladder allows for multiple mounting positions, without relocating a breather vent.

Input Motor Hp	Output RPM 50/60 Hz	Gear Ratio	Max. Safe Torque In. Lbs.	Catalog Number (a)	List Price	Mult. Sym.	Ap'x. Shpg. Wgt.	Motor Type & Gear Style	Enclosure	Voltage	Notes (b)	Drawing Number
Single Phase												
1/12	23/27.7	58:1	75	GC24322	540	DS	13	2420C-CB	TENV	110//115	19,20,78	1
	41/49.6	33:1	62	GC24320	540	DS	13	2420C-CB	TENV	110//115	19,20,78	1
	60/71	22.5	49	GC24318	540	DS	13	2420C-CB	TENV	110//115	19,20,78	1
	123/148	11:1	25	GC24316	540	DS	13	2420C-CB	TENV	110//115	19,20,78	1
Three Phase												
1/6	156	22.5:1	42	GM3331	738	DS	13	2512M-CA	TEFC	208-230/460	20,33	2

(a) Vertical motor below gearhead not recommended.

Avoiding those positions where the high speed oil seal is immersed in oil, will provide greater security against high speed input seal wear.

(b) See notes on inside back flap.

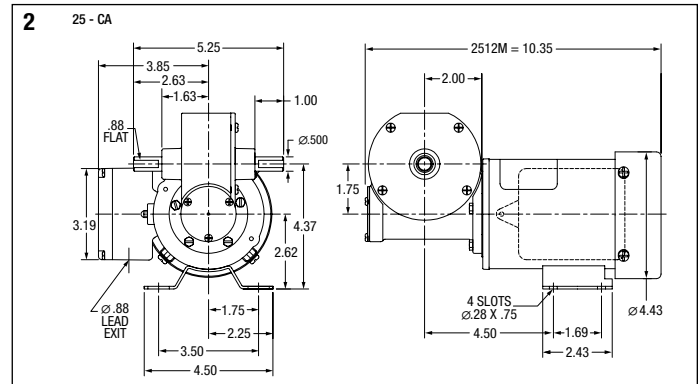
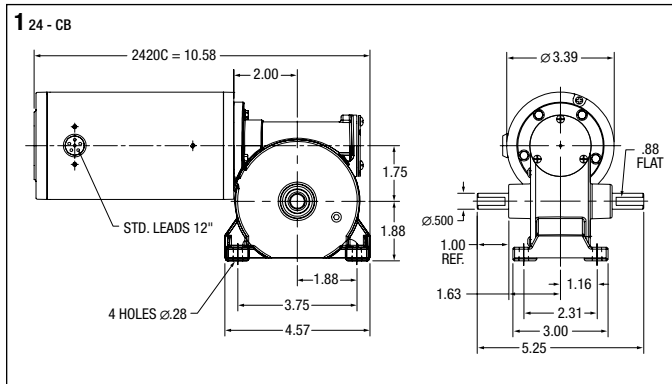

Inverter Gear Motor - 3/8 Hp Right Angle -TEFC



Applications: Ideally suited for conveyors, material handling, packaging equipment applications requiring adjustable speed and no maintenance. Available in a broad range of gear ratios to meet your demanding application needs.

Features: Superior insulation system designed to comply with NEMA MG-1 part 31 for inverter power. IP44 environmental protection. Designed for use on Baldor Series 15J, 15P and Series 5 Inverters operating on 230 volts output. Both Parallel shaft and Right Angle gearmotors are lubricated for life and require no routine maintenance. Right Angle gearmotors feature our internal oil expansion bladder which eliminates the need for a breather while allowing the gearmotor to be mounted in any position (see note below).

Input Motor Hp	Output RPM 60 Hz.	Gear Ratio	Speed Range	Maximum Safe Torque In-Lbs @ 60 Hz	Catalog Number	List Price	Mult. Sym.	Ap'x. Shpg. Wgt.	Motor Type & Gear Style	Volt Code
Right Angle										
3/8	22	75	3.4-33	315	IDGM2509	766	E2	17	2528M-K	C
	28	60	4.5-41	252	IDGM2508	766	E2	17	2528M-K	C
	41	40	6.6-62	228	IDGM2506	766	E2	18	2528M-K	C
	83	20	12-123	138	IDGM2503	766	E2	17	2528M-K	C
	165	10	23.246	105	IDGM2501	766	E2	17	2528M-K	C
	330	5	43-490	68	IDGM2500	766	E2	17	2528M-K	C

NOTE: Avoiding those positions where the high speed oil seal is immersed in oil, will provide greater security against seal wear.

Vertical motor below gearbox mounting is possible with modification, contact Baldor for details.

Voltage: @ 60 Hz: C = 230 volts



GM2503 Shown
JH Style

Applications: General purpose fixed speed including conveyors, material handling equipment and packaging machinery.

Features: Three and single-phase motor designs. High strength bronze gearing, hardened and ground worm for quiet operation. High performance low friction, bidirectional motor seals. Factory lubricated for life, no maintenance required. Internal oil expansion bladder allows for multiple mounting positions, without relocating a breather vent.

Input Motor Hp	Output RPM 50/60 Hz	Gear Ratio	Max. Safe Torque In. Lbs.	Catalog (a) Number	List Price	Mult. Sym.	Ap'x. Shpg. Wgt.	Motor Type & Gear Style	Enclosure	Voltage	Notes (b)	Drawing Number
Single Phase												
1/8	30/37	45:1	125	GC25020	643	DS	16	2524S-JK	TEFC	115	19,20	1
	43/50	33:1	100	GC25015	643	DS	16	2524S-JK	TEFC	115	19,20	1
	62/74	22.5:1	79	GC25010	643	DS	16	2524S-JK	TEFC	115	19,20	1
1/4	126/152	11:1	41	GC25005	643	DS	16	2524S-JK	TEFC	115	19,20	1
	74	22.5:1	125	GC3330	701	DS	26	3324S-JK	TEFC	115	33	2
	151	11:1	70	GC3325	701	DS	26	3324S-JK	TEFC	115	33	2
Three Phase												
1/6	38	45:1	125	GM3337	852	DS	16	2520M-JK	TEFC	208-230/460	20,33	3
	75	22.5:1	85	GM3334	852	DS	15	2520M-JK	TEFC	208-230/460	20,33	3
1/4	104	33:1	75	GM3338	852	DS	16	2520M-JK	TEFC	208-230/460	20,33	3
1/3	34	50:1	256	GM2507	867	DS	18	2528M-JH	TEFC	208-230/460	20,33	4
	42	40:1	230	GM2506	867	DS	18	2528M-JH	TEFC	208-230/460	20,33	4
	84	20:1	155	GM2503	867	DS	18	2528M-JH	TEFC	208-230/460	20,33	4
	168	10:1	90	GM2501	867	DS	18	2528M-JH	TEFC	208-230/460	20,33	4
1/2	35	50:1	295	GM3307	873	DS	26	3320M-JH	TEFC	208-230/460	33	5
	44	40:1	280	GM3306	873	DS	26	3320M-JH	TEFC	208-230/460	33	5
	88	20:1	200	GM3303	873	DS	27	3320M-JH	TEFC	208-230/460	33	5
	175	10:1	135	GM3301	873	DS	26	3320M-JH	TEFC	208-230/460	33	5

(a) Vertical motor below gearhead not recommended. Avoiding those positions where the high speed oil seal is immersed in oil, will provide greater security against high speed input seal wear. (b) See notes on inside back flap.

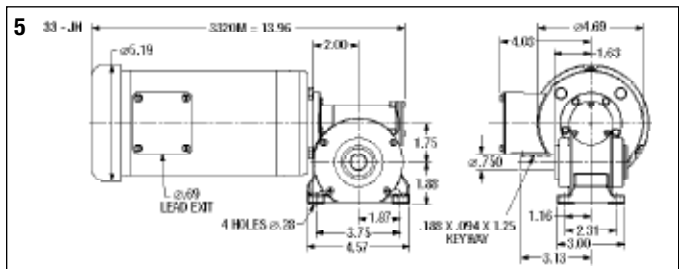
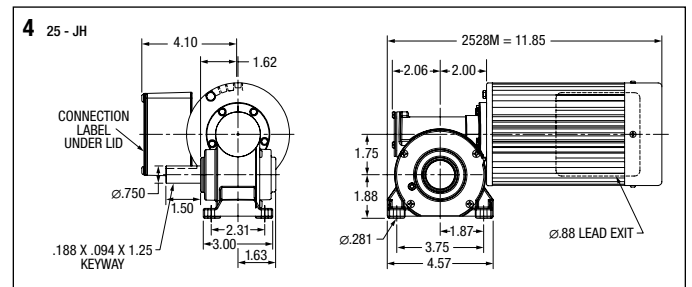
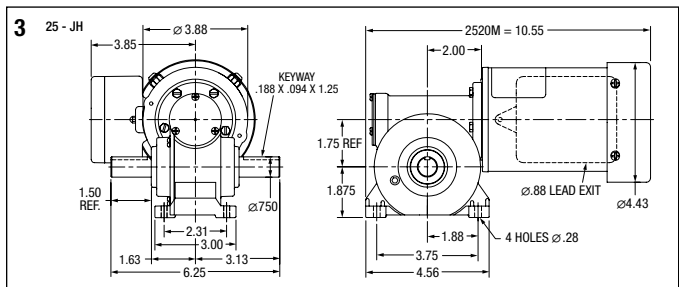
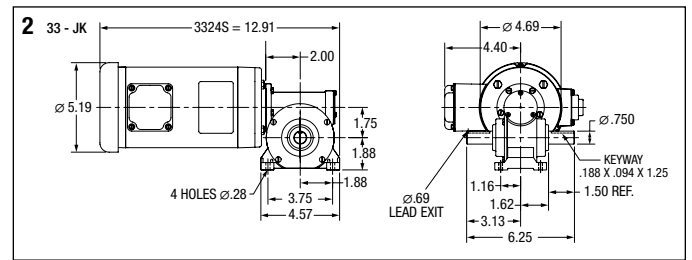
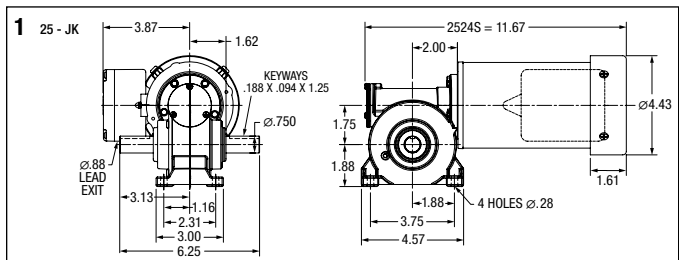

Applications: General purpose fixed speed including conveyors, material handling equipment and packaging machinery.

Features: Three and single-phase motor designs. High strength bronze gearing, hardened and ground worm for quiet operation. Permanently lubricated with synthetic Klubersynth UH1-6-460 oil, USDA food grade lubrication for H1 applications. Internal oil expansion bladder allows for multiple mounting positions, without relocating a breather vent. Double output hollow output bore is 1.00" with keyway for greater mounting flexibility. Supplied with torque arm and cover for exposed end of shaft.



GHL and GHM Shown
H Style

Input Motor Hp	Output RPM 60 Hz	Gear Ratio	Max. Safe Torque In. Lbs.	Catalog (a) Number	List Price	Mult. Sym.	Ap'x. Shpg. Wgt.	Motor Type & Gear Style	Enclosure	Voltage	Notes (b)
Single Phase											
1/2	29	60:1	600	GHL35060	1,123	DS	45	3421L-H	TEFC	115/230	33
	58	30:1	350	GHL35030	1,123	DS	45	3421L-H	TEFC	115/230	33
	88	20:1	250	GHL35020	1,123	DS	45	3421L-H	TEFC	115/230	33
	175	10:1	150	GHL35010	1,123	DS	45	3421L-H	TEFC	115/230	33
3/4	58	30:1	550	GHL37530	1,208	DS	50	3428LC-H	TEFC	115/230	33
	88	20:1	420	GHL37520	1,208	DS	50	3428LC-H	TEFC	115/230	33
	175	10:1	230	GHL37510	1,208	DS	50	3428LC-H	TEFC	115/230	33
1	58	30:1	750	GHL31030	1,379	DS	55	3524L-H	TEFC	115/230	33
	88	20:1	550	GHL31020	1,379	DS	55	3524L-H	TEFC	115/230	33
	175	10:1	300	GHL31010	1,379	DS	55	3524L-H	TEFC	115/230	33
Three Phase											
1/2	29	60:1	600	GHM35060	1,083	DS	40	3416M-H	TEFC	230/460	30,33
	35	50:1	609	GHM35050	1,083	DS	40	3416M-H	TEFC	230/460	30,33
	44	40:1	528	GHM35040	1,083	DS	27	3416M-H	TEFC	230/460	30,33
	58	30:1	350	GHM35030	1,083	DS	40	3416M-H	TEFC	230/460	30,33
	87	20:1	200	GHM35020	1,083	DS	40	3416M-H	TEFC	230/460	30,33
	174	10:1	135	GHM35010	1,083	DS	40	3416M-H	TEFC	230/460	30,33
3/4	58	30:1	550	GHM37530	1,114	DS	42	3420M-H	TEFC	208-230/460	33
	88	20:1	420	GHM37520	1,114	DS	42	3420M-H	TEFC	208-230/460	33
	175	10:1	230	GHM37510	1,114	DS	42	3420M-H	TEFC	208-230/460	33
1	58	30:1	750	GHM31030	1,144	DS	48	3426M-H	TEFC	208-230/460	33
	88	20:1	550	GHM31020	1,144	DS	45	3426M-H	TEFC	208-230/460	33
	175	10:1	300	GHM31010	1,144	DS	45	3426M-H	TEFC	208-230/460	33

(a) Vertical motor below gearhead not recommended.

Avoiding those positions where the high speed oil seal is immersed in oil, will provide greater security against high speed input seal wear.

(b) See notes on inside back flap.

H Gearbox Accessories



Baldor offers optional base and shaft kits for H style gearmotors. Adding a base and shaft kit allows them to be used in applications requiring a right-angle shaft extension. The shaft can be used for either right or left hand output applications.

Catalog Number	Description	List Price	Mult. Sym.	Ap'x. Shpg. Wgt.
B19H71	Horiz Base Kit	82	A8	1
SH10HS	Output Shaft Kit	26	A8	2



GP231003 Shown
FTA Style

Applications: Conveyors, medical and laboratory equipment, printing presses, commercial ovens, machine tools and other applications requiring adjustable speed.

Features: DCPM motor provides exceptional starting torque, adjustable speed, and predictable performance over a wide range of operating conditions. Bronze sleeve bearing on output for smooth torque transmission. High strength bronze gearing and hardened and ground worm for quiet operation. Hardened and ground worm for quiet operation. Permanently lubricated with synthetic grease lubrication, can be mounted in all positions including vertical motor below gearhead.

Input Motor Hp	Output Base Speed	Gear Ratio	Max. Safe Torque In. Lbs.	Catalog Number	List Price	Mult. Sym.	Ap'x. Shpg. Wgt.	Motor Type & Gear Style	Voltage D.C. Armature	Full Load Amperage Armature	Notes (a)
90 VDC											
1/50	87	20:1	7.3	GP231003	407	DS	5	2308P-FTA	90	0.34	20
1/25	140	12:1	11	GP231002	439	DS	5	2314P-FTA	90	0.54	20
1/17	312	8:1	6	GP231001	439	DS	5	2314P-FTA	90	0.62	20
1/25	344	5:1	5.1	GP232001	439	DS	5	2314P-FTA	90	0.49	20

(a) See notes on inside back flap.

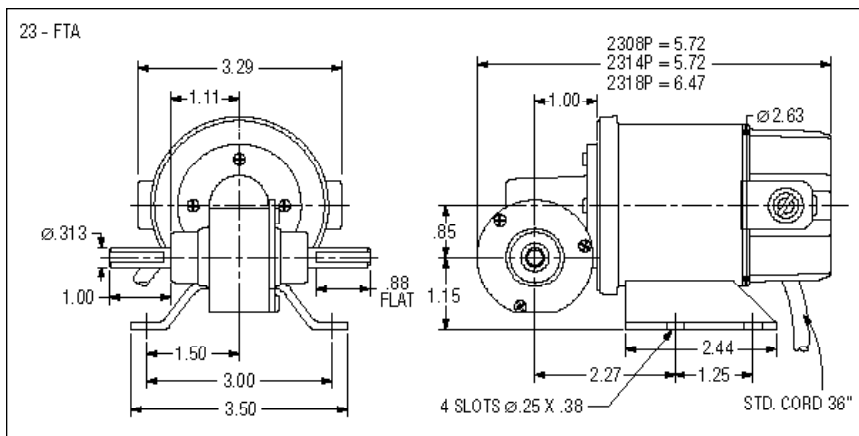



Applications: Conveyors, medical and laboratory equipment, printing presses, commercial ovens, machine tools and other applications requiring adjustable speed.

Features: DCPM motor provides exceptional starting torque, adjustable speed, and predictable operating conditions. High strength bronze gearing for increased torque capacity. High performance low friction, bidirectional motor seals. Permanently lubricated for life with synthetic grease lubrication, can be mounted in all positions including vertical motor below gearhead.

GP231005 Shown
GNA Style

Input Motor Hp	Output Base Speed	Gear Ratio	Max. Safe Torque In. Lbs.	Catalog Number	List Price	Mult. Sym.	Ap'x. Shpg. Wgt.	Motor Type & Gear Style	Voltage D.C. Armature	Full Load Amperage Armature	Notes (a)
90 VDC											
1/97	8.2	225:1	15	GP231005	427	DS	5	2308P-GNA	90	0.19	20

(a) See notes on inside back flap.

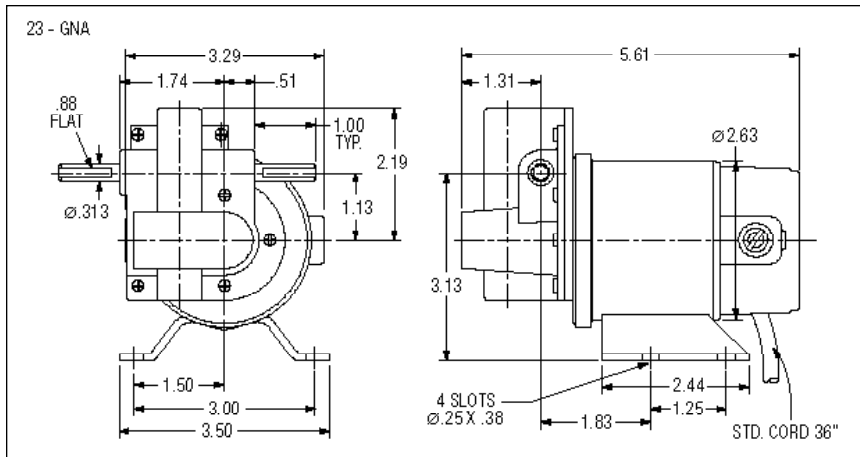

Gearmotors and Gear Products

Motor Accessories

PT Components

Grinders

Baldor Mod Express

ABB Mod Express

Product Index



GP232002 Shown
BA Style

Applications: Conveyors, medical and laboratory equipment, printing presses, commercial ovens, machine tools and other applications requiring adjustable speed.

Features: DCPM motor provides exceptional starting torque, adjustable speed, and predictable performance over a wide range of operating conditions. Permagliding sleeve bearing on output for smooth torque transmission. High strength bronze gearing, hardened and ground worm for quiet operation. High performance low friction, bidirectional motor seals. Permanently lubricated with synthetic oil. Internal oil expansion chamber allows for all position mounting without relocating a breather vent.

Input Motor Hp	Output Base Speed	Gear Ratio	Max. Safe Torque In. Lbs.	Catalog (a) Number	List Price	Mult. Sym.	Ap'x. Shpg. Wgt.	Motor Type & Gear Style	Voltage D.C. Armature	Full Load Amperage Armature	Notes (b)
90 VDC											
1/22	40	40:1	30	GP232002	542	DS	7	2314P-BA	90	0.60	20
1/16	60	30:1	33	GP233003	561	DS	8	2318P-BA	90	0.72	20
	90	20:1	27	GP233002	561	DS	7	2318P-BA	90	0.75	20
	120	15:1	22	GP233007	561	DS	7	2318P-BA	90	0.78	20
	173	10:1	17	GP233001	561	DS	7	2318P-BA	90	0.85	20
180 VDC											
1/16	60	30:1	33	GP233023	561	DS	7	2318P-BA	180	0.42	20
1/14	86	20:1	28	GP233022	561	DS	7	2318P-BA	180	0.42	20
1/16	175	10:1	17	GP233021	561	DS	7	2318P-BA	180	0.42	20

(a) Vertical motor below gearhead not recommended.

Avoiding those positions where the high speed oil seal is immersed in oil, will provide greater security against high speed input seal wear.

(b) See notes on inside back flap.

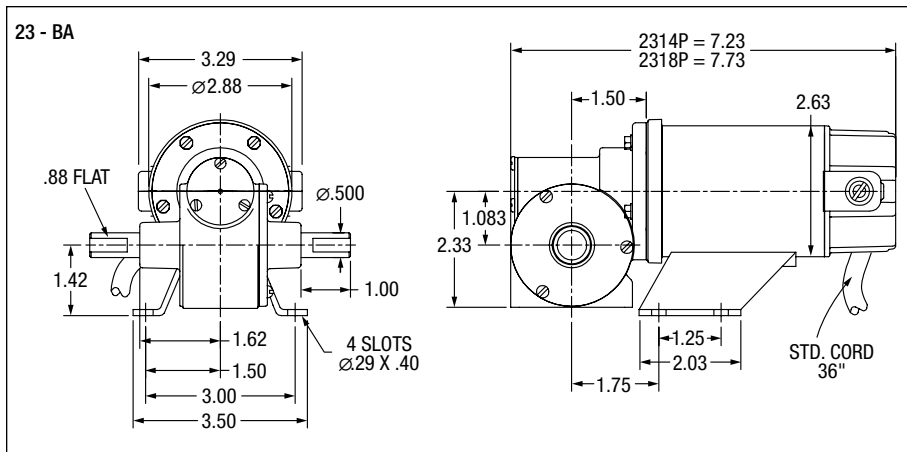



GP232004 Shown
DA Style

Applications: Conveyors, medical and laboratory equipment, printing presses, commercial ovens, machine tools and other applications requiring adjustable speed.

Features: DCPM motor provides exceptional starting torque, adjustable speed and predictable operating conditions. High strength bronze gearing for increased torque capacity. High performance low friction, bidirectional motor seals. Permanently lubricated with synthetic grease lubrication, can be mounted in all positions including vertical motor below gearhead.

Input Motor Hp	Output Base Speed	Gear Ratio	Max. Safe Torque In. Lbs.	Catalog (a) Number	List Price	Mult. Sym.	Ap'x. Shpg. Wgt.	Motor Type & Gear Style	Voltage D.C. Armature	Full Load Amperage Armature	Notes (b)
90 VDC											
1/66	1.7	1100:1	75	GP232004	606	DS	7	2308P-DA	90	0.18	20
1/49	3.7	660:1	75	GP232005	606	DS	7	2308P-DA	90	0.34	20
1/27	8.7	310:1	66	GP232006	606	DS	7	2314P-DA	90	0.44	20
1/15	19.6	130:1	64	GP232007	632	DS	7	2314P-DA	90	0.68	20
180 VDC											
1/83	1.9	1100:1	75	GP233020	632	DS	7	2314P-DA	180	0.11	20
1/31	4.1	660:1	75	GP233029	632	DS	7	2314P-DA	180	0.20	20
1/22	8.5	310:1	66	GP233028	632	DS	7	2314P-DA	180	0.26	20
1/20	19.7	130:1	64	GP233027	660	DS	7	2314P-DA	180	0.31	20

(a) Vertical motor below gearhead not recommended.

Avoiding those positions where the high speed oil seal is immersed in oil, will provide greater security against high speed input seal wear.

(b) See notes on inside back flap.

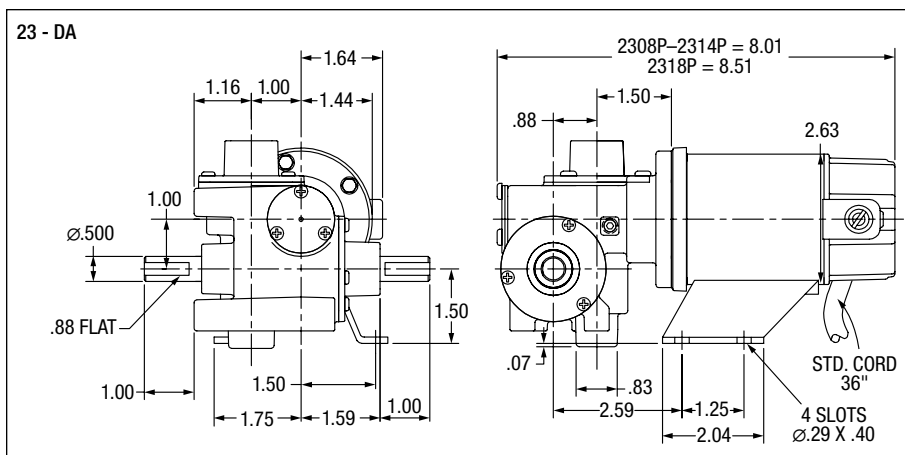



GP7409 Shown
EB Style

Applications: Conveyors, medical and laboratory equipment, printing presses, commercial ovens, machine tools and other applications requiring adjustable speed.

Features: DCPM motor provides exceptional starting torque, adjustable speed, and predictable operating conditions. High strength bronze gearing for increased torque capacity. High performance low friction, bidirectional motor seals. Permanently lubricated with synthetic grease lubrication, can be mounted in all positions including vertical motor below gearhead.

Input Motor Hp	Output Base Speed	Gear Ratio	Max. Safe Torque In. Lbs.	Catalog Number	List Price	Mult. Sym.	Ap'x. Shpg. Wgt.	Motor Type & Gear Style	Voltage D.C. Armature	Full Load Amperage Armature	Notes (a)
90 VDC											
1/8	6	600:1	150	GP7304	889	DS	13	2412P-EB	90	1.00	20
1/4	20	180:1	175	GP7409	848	DS	15	2424P-EB	90	2.00	20
180 VDC											
1/4	20	180:1	175	GP7429	875	DS	15	2424P-EB	180	1.00	20

(a) See notes on inside back flap.

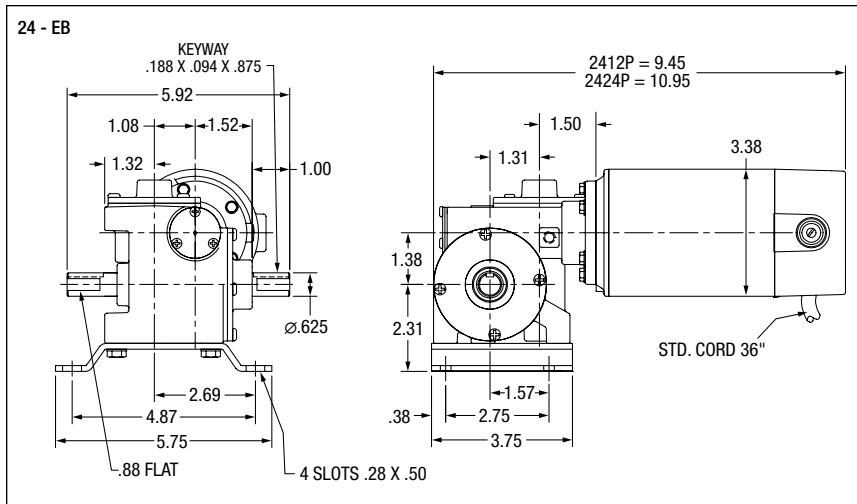



GP24280 Shown
G Style

Applications: Conveyors, medical and laboratory equipment, printing presses, commercial ovens, machine tools and other applications requiring adjustable speed.

Features: Bronze and hardened steel worm gear first stage, hardened steel helical output stage for improved overall efficiency and dependable torque transmission. Completely sealed from the environment and pre-lubricated with synthetic oil, it can be put into immediate service and does not require periodic oil changes. G gear style can be face mounted on the output shaft side, or from the bottom of the gear housing.

Input Motor Hp	Output Base Speed	Gear Ratio	Max. Safe Torque In. Lbs.	Catalog (a) Number	List Price	Mult. Sym.	Ap'x. Shpg. Wgt.	Motor Type & Gear Style	Voltage D.C. Armature	Full Load Amperage Armature	Notes (b)
90 VDC											
1/8	6.2	280:1	400	GP24280	965	DS	16	2424P-G	90	1.80	20
	9.1	190:1	385	GP24190	965	DS	15	2424P-G	90	1.80	20
	14	120:1	280	GP24120	965	DS	16	2424P-G	90	1.80	20
	29	60:1	163	GP24060	965	DS	16	2424P-G	90	1.80	20

(a) Vertical motor below gearhead not recommended.

Avoiding those positions where the high speed oil seal is immersed in oil, will provide greater security against high speed input seal wear.

(b) See notes on inside back flap.

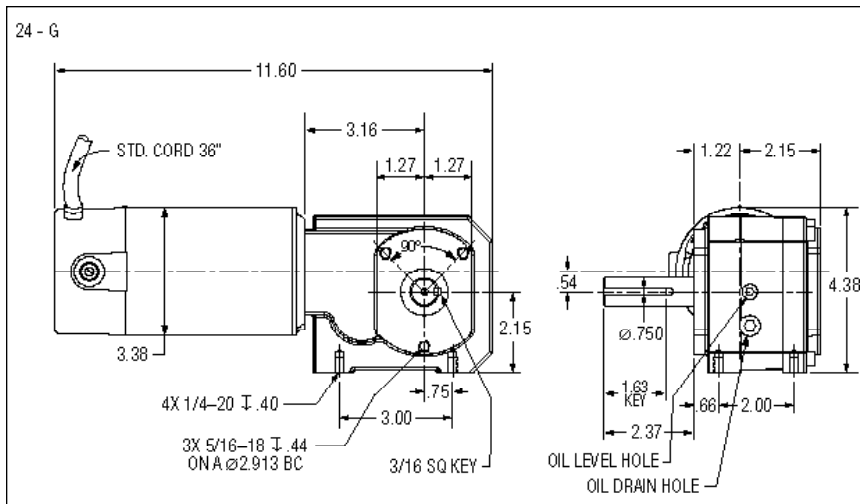



GP13530 Shown
K Style

Applications: Conveyors, medical and laboratory equipment, printing presses, commercial ovens, machine tools and other applications requiring adjustable speed.

Features: DCPM motor provides exceptional starting torque, adjustable speed, and predictable operating conditions. Ball bearing on output for smooth torque transmission and increased radial load capacity. High strength bronze gearing, hardened and ground worm for quiet operation. High performance low friction, bi-directional motor seals. Permanently lubricated with synthetic oil. Internal oil expansion chamber allows for all position mounting without relocating a breather vent.

Input Motor Hp	Output Base Speed	Gear Ratio	Max. Safe Torque In. Lbs.	Catalog (a) Number	List Price	Mult. Sym.	Ap'x. Shpg. Wgt.	Motor Type & Gear Style	Voltage D.C. Armature	Full Load Amperage Armature	Notes (b)
90 VDC											
1/12	43	40:1	73	GP12511	690	DS	10	125-K	90	0.90	20
	86	20:1	39	GP12512	690	DS	10	125-K	90	0.90	20
	173	10:1	22	GP12514	690	DS	10	125-K	90	0.90	20
	346	5:1	10	GP12516	690	DS	10	125-K	90	0.90	20
1/6	43	40:1	135	GP13530	725	DS	13	135-K	90	1.73	20
	57	30:1	111	GP13531	725	DS	13	135-K	90	1.73	20
	88	20:1	88	GP13532	725	DS	13	135-K	90	1.73	20
	173	10:1	48	GP13533	725	DS	13	135-K	90	1.73	20
	346	5:1	24	GP13536	725	DS	13	135-K	90	1.73	20

(a) Vertical motor below gearhead not recommended.

Avoiding those positions where the high speed oil seal is immersed in oil, will provide greater security against high speed input seal wear.

(b) See notes on inside back flap.

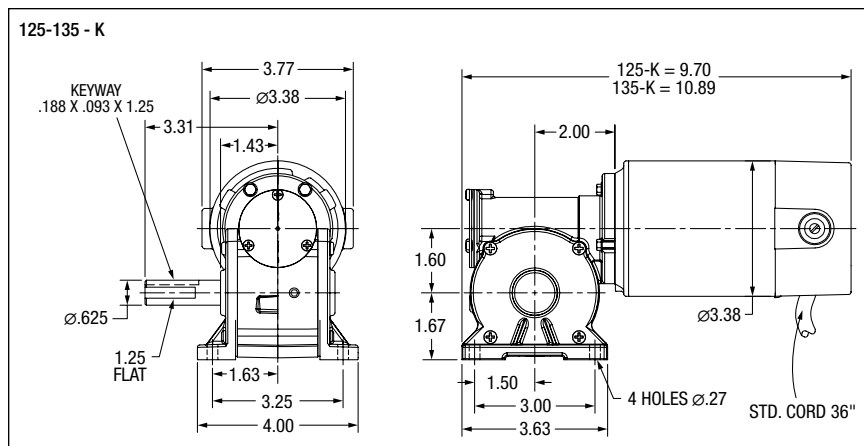



GP231004 Shown
CB Style

Applications: Conveyors, medical and laboratory equipment, printing presses, commercial ovens, machine tools and other applications requiring adjustable speed.

Features: DCPM motor provides exceptional starting torque, adjustable speed, and predictable performance over a wide range of operating conditions. Permaglide sleeve bearing on output for smooth torque transmission. High strength bronze gearing, hardened and ground worm for quiet operation. High performance low friction, bidirectional motor seals. Permanently lubricated with synthetic oil. Internal oil expansion chamber allows for all position mounting without relocating a breather vent.

Input Motor Hp	Output Base Speed	Gear Ratio	Max. Safe Torque In. Lbs.	Catalog (a) Number	List Price	Mult. Sym.	Ap'x. Shpg. Wgt.	Motor Type & Gear Style	Voltage D.C. Armature	Full Load Amperage Armature	Notes (b)
90 VDC											
1/25	22	72:1	45	GP231004	542	DS	8	2314P-CB	90	0.53	20
	30	58:1	38	GP232003	542	DS	8	2314P-CB	90	0.53	20
1/16	38	45:1	57	GP233006	561	DS	8	2318P-CB	90	0.80	20
	52	33:1	48	GP233005	561	DS	8	2318P-CB	90	0.75	20
	76	22.5:1	33	GP233004	561	DS	8	2318P-CB	90	0.85	20
180 VDC											
1/16	41	45:1	57	GP233026	561	DS	8	2318P-CB	180	0.42	20
	53	33:1	48	GP233025	561	DS	8	2318P-CB	180	0.40	20
1/14	76	22.5:1	76	GP233024	561	DS	8	2318P-CB	180	0.42	20

(a) Vertical motor below gearhead not recommended.

Avoiding those positions where the high speed oil seal is immersed in oil, will provide greater security against high speed input seal wear.

(b) See notes on inside back flap.

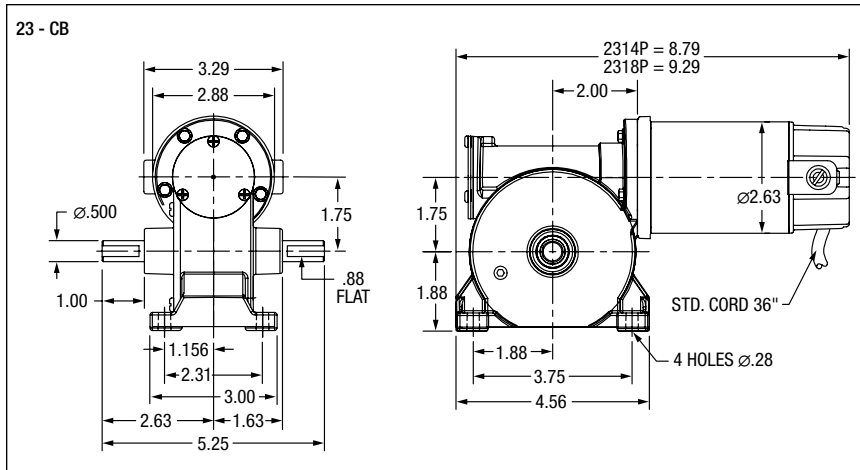



GP7404 Shown
JK Style

Applications: Conveyors, medical and laboratory equipment, printing presses, commercial ovens, machine tools and other applications requiring adjustable speed.

Features: DCPM motor provides exceptional starting torque, adjustable speed, and predictable operating conditions. Ball bearing on output for smooth torque transmission and increased radial load capacity High strength bronze gearing, hardened and ground worm for quiet operation. High performance low friction, bidirectional motor seals. Factory lubricated with synthetic oil. Internal oil expansion chamber allows for all position mounting without relocating a breather vent.

Input Motor Hp	Output Base Speed	Gear Ratio	Max. Safe Torque In. Lbs.	Catalog Number ^(a)	List Price	Mult. Symb.	Ap'x. Shpg. Wgt.	Motor Type & Gear Style	Voltage D.C. Armature	Full Load Amperage Armature	Notes ^(b)	Drawing Number
90 VDC												
1/8	30	58:1	120	GP7404	770	DS	14	2424P-JK	90	1.30	20	1
	38	45:1	100	GP7403	770	DS	14	2424P-JK	90	1.30	20	1
	52	33:1	75	GP7402	770	DS	14	2424P-JK	90	1.30	20	1
	75	22.5:1	60	GP7401	770	DS	14	2424P-JK	90	1.30	20	1
1/5	173	11:1	32	GP7400	770	DS	14	2424P-JK	90	1.30	20	1
	50	45:1	120	GP7408	770	DS	14	2428P-JK	90	2.20	20	1
1/4	68	33:1	112	GP7405	770	DS	14	2428P-JK	90	2.40	20	1
	76	45:1	100	GP7407	770	DS	14	2428P-JK	90	2.60	20	1
	104	33:1	75	GP7406	770	DS	14	2428P-JK	90	2.60	20	1
	314	8:1	32	GP7413	770	DS	14	2428P-JK	90	2.60	20	1
1/3	48	50:1	150	GP2507	944	DS	21	2532P-JH	90	3.36	20	2
	62	40:1	137	GP2506	944	DS	21	2532P-JH	90	3.36	20	2
	123	20:1	95	GP2503	944	DS	21	2532P-JH	90	3.36	20	2
	245	10:1	65	GP2501	944	DS	21	2532P-JH	90	3.36	20	2
1/2	50	50:1	234	GP3307	1,096	DS	30	3327P-JH	90	5.00	20	3
	63	40:1	215	GP3306	1,096	DS	30	3327P-JH	90	5.00	20	3
	125	20:1	145	GP3303	1,096	DS	30	3327P-JH	90	5.00	20	3
	250	10:1	100	GP3301	1,096	DS	30	3327P-JH	90	5.00	20	3
180 VDC												
1/8	30	58:1	120	GP7424	770	DS	14	2420P-JK	180	0.64	20	1
	38	45:1	100	GP7423	770	DS	14	2420P-JK	180	0.64	20	1
	52	33:1	75	GP7422	770	DS	14	2420P-JK	180	0.64	20	1
	78	22.5:1	60	GP7421	770	DS	14	2420P-JK	180	0.64	20	1
1/5	173	11:1	32	GP7420	770	DS	14	2420P-JK	180	0.65	20	1
	50	45:1	120	GP7428	770	DS	14	2428P-JK	180	1.10	20	1
1/4	68	45:1	135	GP7425	770	DS	14	2428P-JK	180	1.30	20	1
	76	45:1	100	GP7427	770	DS	14	2428P-JK	180	1.30	20	1
	104	33:1	75	GP7426	770	DS	14	2428P-JK	180	1.30	20	1
	314	11:1	32	GP7433	770	DS	14	2428P-JK	180	1.30	20	1

^(a) Vertical motor below gearhead not recommended. Avoiding those positions where the high speed oil seal is immersed in oil, will provide greater security against high speed input seal wear.

^(b) See notes on inside back flap.

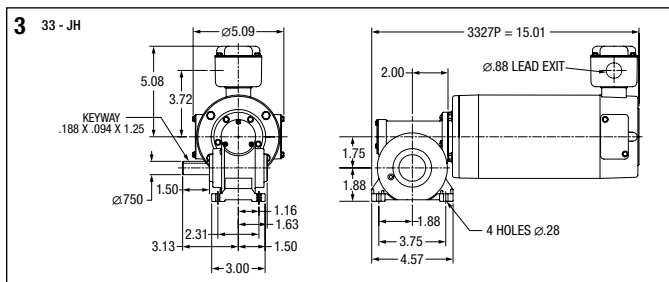
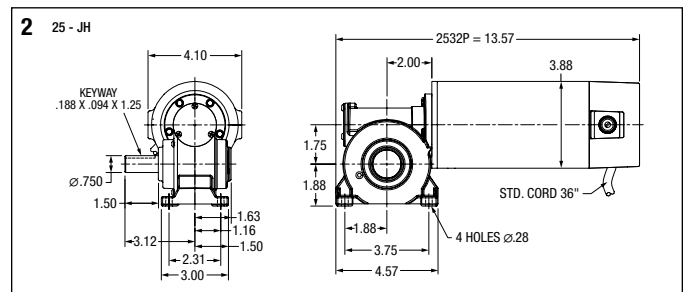
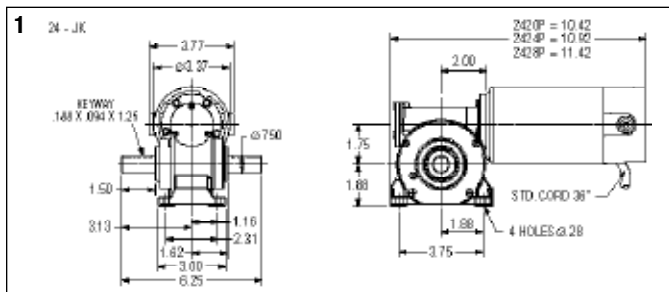



GPF13517 Shown
JAF Style

Applications: Conveyors, medical and laboratory equipment, printing presses, commercial ovens, machine tools and other applications requiring adjustable speed.

Features: DCPM motor provides exceptional starting torque, adjustable speed, and predictable operating conditions. Ball bearing on output for smooth torque transmission and increased radial load capacity. High strength bronze gearing, hardened and ground worm for quiet operation. High performance low friction, bi-directional motor seals. Factory lubricated with synthetic oil. Internal oil expansion chamber allows for all position mounting without relocating a breather vent.

Input Motor Hp	Output Base Speed	Gear Ratio	Max. Safe Torque In. Lbs.	Catalog Number ^(a)	List Price	Mult. Sym.	Ap'x. Shpg. Wgt.	Motor Type & Gear Style	Voltage D.C. Armature	Full Load Amperage Armature	Notes ^(b)
90 VDC											
1/4	312	8:1	38.0	GPF13514	799	DS	15	2428P-JAF	90	2.5	20
	167	15:1	69.0	GPF13515	799	DS	15	2428P-JAF	90	2.5	20
	111	22.5:1	96.0	GPF13516	799	DS	15	2428P-JAF	90	2.6	20
	76	33:1	110.0	GPF13517	799	DS	15	2428P-JAF	90	2.2	20
180 VDC											
1/5	167	15:1	55.0	GPF13530	799	DS	15	135-JAF	180	1.0	20
	76	33:1	88.0	GPF13532	799	DS	15	135-JAF	180	1.0	20

(a) Vertical motor below gearhead not recommended.

Avoiding those positions where the high speed oil seal is immersed in oil, will provide greater security against high speed input seal wear.

(b) See notes on inside back flap.

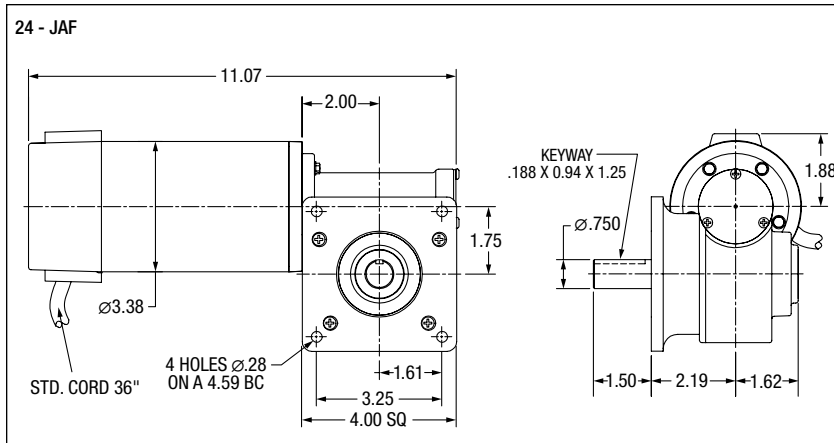



GCP24114 Shown
PSSH Style

Applications: Conveyors, packaging machines, machine tools and laboratory equipment requiring constant speed.

Features: Induction hardened helical and spur gears for extra strength. Ball and needle-bearing construction for improved torque capacity. Factory lubricated for life, no maintenance required. Industry standard dimensions. See optional mounting bracket on pages 292 and 327.

Input Motor Hp	Output RPM 50/60 Hz.	Gear Ratio	Stages	Max. Safe Torque In. Lbs.	Catalog (a) Number	List Price	Mult. Sym.	Ap'x. Shpg. Wgt.	Motor Type & Gear Style	Enclosure	Voltage	Notes (b)	Drawing Number
Single Phase													
1/100	1.1/1.3	1320	5	101	GCP24369	595	DS	10	2412C-PSSH	TENV	115	19,20,78	2
	1.9/2.3	720	5	100	GCP24702	595	DS	10	2412C-PSSH	TENV	115	19,20,78	2
1/80	4.3/5.2	320	4	100	GCP24362	595	DS	10	2412C-PSSH	TENV	115	19,20,78	2
	7.7/9.2	180	4	76	GCP24186	567	DS	10	2412C-PSSH	TENV	115	19,20,78	2
1/40	7.6/9.4	180:1	4	120	GCP24114	557	DS	10	2412C-PSSH	TENV	115	19,20,78	2
1/25	15.3/18	90:1	4	120	GCP24122	561	DS	10	2416C-PSSH	TENV	115	19,20,78	2
	23/27.3	60:1	3	80.7	GCP24124	561	DS	10	2416C-PSSH	TENV	115	19,20,78	1
1/20	14/16	100	3	100	GCP24100	588	DS	10	2416C-PSSH	TENV	115	19,20,78	2
	18/22	75	3	100	GCP24072	588	DS	10	2416C-PSSH	TENV	115	19,20,78	2
	28/33	50	3	96	GCP24050	542	DS	10	2416C-PSSH	TENV	115	19,20,78	1
	36/43	37.95	3	62	GCP24037	542	DS	10	2416C-PSSH	TENV	115	19,20,78	1
	55/66	25	2	49	GCP24026	542	DS	10	2416C-PSSH	TENV	115	19,20,78	1
	84/100	16.43	2	30	GCP24017	508	DS	10	2416C-PSSH	TENV	115	19,20,78	1
	109/130	12.65	2	25	GCP24013	508	DS	10	2416C-PSSH	TENV	115	19,20,78	1
	138/165	10	2	20	GCP24010	508	DS	10	2416C-PSSH	TENV	115	19,20,78	1
	210/252	6.55	2	13	GCP24007	508	DS	10	2416C-PSSH	TENV	115	19,20,78	1
1/12	275/330	5	2	10	GCP24005	508	DS	10	2416C-PSSH	TENV	115	19,20,78	1
	45/54.8	30:1	3	83.7	GCP24134	540	DS	10	2424C-PSSH	TENV	115	19,20,78	1
	68/82.5	20:1	2	55.8	GCP24136	540	DS	10	2424C-PSSH	TENV	115	19,20,78	1
	90/109	15:1	2	42.8	GCP24138	540	DS	10	2424C-PSSH	TENV	115	19,20,78	1
	136/163	10:1	2	28.5	GCP24140	540	DS	10	2424C-PSSH	TENV	115	19,20,78	1
	272/326	5:1	2	14.3	GCP24142	540	DS	10	2424C-PSSH	TENV	115	19,20,78	1

(a) Vertical motor below gearhead not recommended.

Avoiding those positions where the high speed oil seal is immersed in oil, will provide greater security against high speed input seal wear.

(b) See notes on inside back flap.

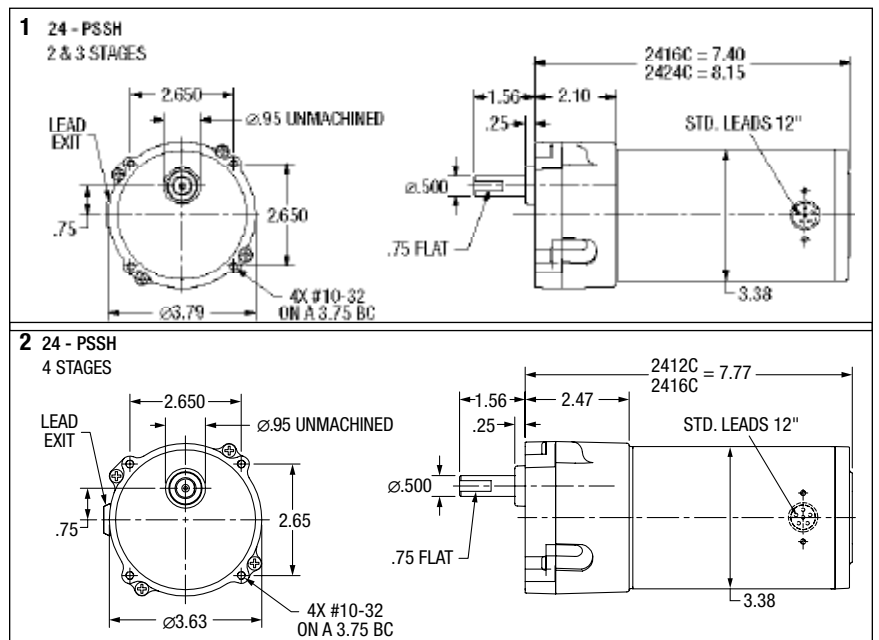

Gearmotors and Gear Products

Motor Accessories

PT Components

Grinders

Baldor Mod Express

ABB Mod Express

Product Index



GCP24232 Shown
PSM Style

Applications: Conveyors, packaging machines, machine tools and laboratory equipment requiring constant speed.

Features: Induction hardened helical and spur gears for extra strength. Ball and needle-bearing construction for improved torque capacity. Factory lubricated for life, no maintenance required. Industry standard dimensions. Optional bases for foot or 3-point face mounting, see below.

Input Motor Hp	Output RPM 50/60 Hz.	Gear Ratio	Stages	Max. Safe Torque In. Lbs.	Catalog (a) Number	List Price	Mult. Sym.	Ap'x. Shpg. Wgt.	Motor Type & Gear Style	Enclosure	Voltage	Notes (b)	Drawing Number
Single Phase													
1/15	15/18	90:1	4	237	GCP24232	647	DS	14	2424C-PSM	TENV	115	19,20,78	1
1/12	23/27	60:1	3	167	GCP24234	612	DS	14	2424C-PSM	TENV	115	19,20,78	1
1/9	43/36	40:1	3	149	GCP25052	617	DS	14	2524S-PSM	TEFC	115	19,20	2
	47/57	30:1	3	112	GCP25054	617	DS	14	2524S-PSM	TEFC	115	19,20	2
	84/70	20:1	3	74	GCP25056	587	DS	14	2524S-PSM	TEFC	115	19,20	2
	92/111	15:1	2	57	GCP25058	587	DS	14	2524S-PSM	TEFC	115	19,20	2
	138/166	10:1	2	38	GCP25060	587	DS	14	2524S-PSM	TEFC	115	19,20	2
	275/330	5:1	2	19	GCP25062	587	DS	14	2524S-PSM	TEFC	115	19,20	2

(a) Vertical motor below gearhead not recommended.

Avoiding those positions where the high speed oil seal is immersed in oil, will provide greater security against high speed input seal wear.

(b) See notes on inside back flap.

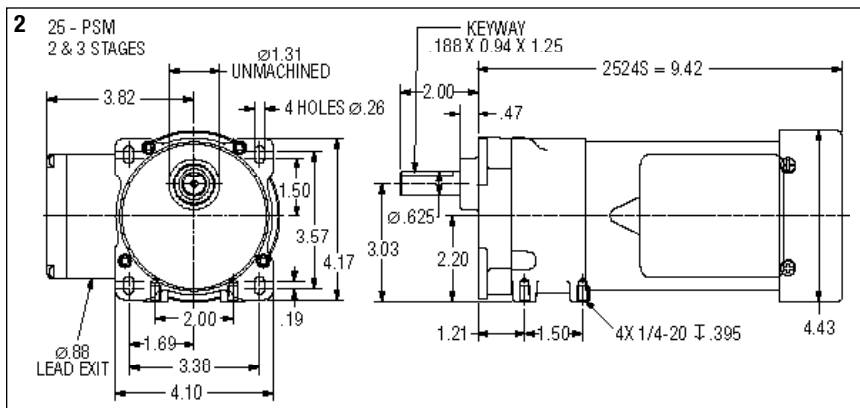
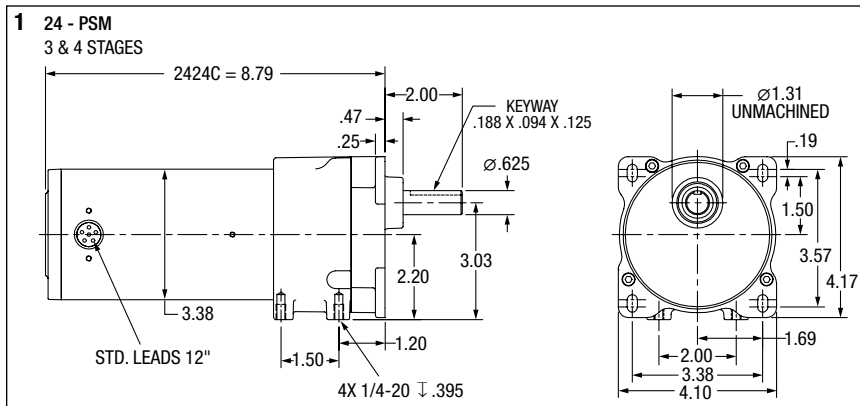

PSM Mounting Adapters

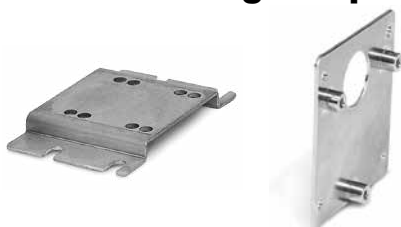

B92 is formed steel mounting base that bolts to machined surface on bottom of PSM gear box casting. Provides secure foot mounting of gearmotor and drop-in interchangeability with other major manufacturers.

B93 is a three point face mounting adapter. Provides interchangeability with other manufacturers.

Catalog Number	Description	List Price	Mult. Sym.	Ap'x. Shpg. Wgt.
B92	Foot Mount	49	A8	1
B93	3 Point Face Mount	62	A8	1



PSL Style

Applications: Conveyors, packaging machines, machine tools and laboratory equipment requiring constant speed.

Features: Three and single-phase. Induction hardened helical gears for added strength. Ball and needle-bearing construction for improved torque capacity. Factory lubricated for life, no maintenance required. Industry standard dimensions. An optional bolt-on base is available for foot mounting on pages 292 and 327.

Input Motor Hp	Output RPM 50/60 Hz.	Gear Ratio	Stages	Max. Safe Torque In. Lbs.	Catalog Number ^(a)	List Price	Mult. Sym.	Ap'x. Shpg. Wgt.	Motor Type & Gear Style	Enclosure	Voltage	Notes ^(b)	Drawing Number
Single Phase													
1/25	4.5/5.5	300:1	4	325	GCP24002	830	DS	15	2416C-PSL	TENV	110//115	19,20,78	1
	7.6/9.1	180:1	4	235	GCP24004	830	DS	15	2416C-PSL	TENV	110//115	19,20,78	1
1/12	11/13.7	120:1	4	330	GCP24020	896	DS	15	2424C-PSL	TENV	110//115	19,20,78	1
	15/18.2	90:1	4	250	GCP24022	803	DS	15	2424C-PSL	TENV	110//115	19,20,78	1
1/8	23/28	60:1	3	270	GCP25002	870	DS	18	2524S-PSL	TEFC	110//115	19,20	2
	45/55	30:1	3	135	GCP25004	870	DS	18	2524S-PSL	TEFC	110//115	19,20	2
	71/85	20:1	2	92	GCP25006	840	DS	18	2524S-PSL	TEFC	110//115	19,20	3
	141/170	10:1	2	46	GCP25008	840	DS	18	2524S-PSL	TEFC	110//115	19,20	3
	283/340	5:1	2	23	GCP25010	840	DS	18	2524S-PSL	TEFC	110//115	19,20	3
	6.4/7.7	215.6	4	310	GCP25216	848	DS	15	2524C-PSL	TEFC	115/230	19,20	2
1/6	13/16	102.4	3	350	GCP25102	848	DS	15	2524C-PSL	TEFC	115/230	19,20	2
	17/20	81.8	3	300	GCP25082	848	DS	15	2524C-PSL	TEFC	115/230	19,20	2
	23/28	58.3	3	300	GCP25658	796	DS	15	2524C-PSL	TEFC	115/230	19,20	2
	58	30:1	3	164	GCP3305	881	DS	24	3316C-PSL	TENV	115	33	4
	86	20:1	2	112	GCP3310	849	DS	24	3316C-PSL	TENV	115	33	4
	173	10:1	2	56	GCP3315	849	DS	24	3316C-PSL	TENV	115	33	4
1/4	39/47	35.8	3	294	GCP25036	870	DS	24	3324S-PSL	TEFC	115/230	19,20	5
	48/58	28.1	3	227	GCP25029	870	DS	24	3324S-PSL	TEFC	115/230	19,20	5
	73/88	19.1	2	163	GCP25019	819	DS	24	3324S-PSL	TEFC	115/230	19,20	5
	94/113	15	2	128	GCP25015	819	DS	24	3324S-PSL	TEFC	115/230	19,20	5
	133/159	10.6	2	91	GCP25011	819	DS	24	3324S-PSL	TEFC	115/230	19,20	5
	282/338	5	2	41	GCP25005	819	DS	24	3324S-PSL	TEFC	115/230	19,20	5
Capacitor Start - Single Phase													
1/4	29	60:1	3	483	GLP3310	952	DS	25	3320L-PSLH	TEFC	115/208-230	33	5
	35	50:1	3	438	GLP3328	990	DS	28	3324L-PSLH	TEFC	115/208-230	20,33	5
	57.5	30:1	3	320	GLP3330	990	DS	25	3324L-PSLH	TEFC	115/208-230	20,33	5
1/3	86.3	20:1	2	218	GLP3332	931	DS	25	3324L-PSLH	TEFC	115/208-230	20,33	5
	172.5	10:1	2	109	GLP3336	931	DS	27	3324L-PSLH	TEFC	115/208-230	20,33	5
	345	5:1	2	55	GLP3338	931	DS	25	3324L-PSLH	TEFC	115/208-230	20,33	5
1/2	58	30:1	3	484	GLP3342	1,044	DS	32	3328L-PSLH	TEFC	115/208-230	20,33	5
	88	20:1	2	326	GLP3344	985	DS	31	3328L-PSLH	TEFC	115/208-230	20,33	5
	117	15:1	2	245	GLP3346	985	DS	31	3328L-PSLH	TEFC	115/208-230	20,33	5
	175	10:1	2	164	GLP3348	985	DS	31	3328L-PSLH	TEFC	115/208-230	20,33	5
Three Phase													
1/3	57	30:1	3	320	GMP3330	980	DS	27	3320M-PSLH	TEFC	208-230/460	33	6
	86	20:1	2	218	GMP3332	921	DS	27	3320M-PSLH	TEFC	208-230/460	33	6
	173	10:1	2	109	GMP3336	921	DS	25	3320M-PSLH	TEFC	208-230/460	33	6
	345	5:1	2	55	GMP3338	921	DS	24	3320M-PSLH	TEFC	208-230/460	33	6
1/2	43	40:1	3	627	GMP3340	1,035	DS	27	3320M-PSLH	TEFC	208-230/460	33	6
	58	30:1	3	484	GMP3342	1,035	DS	27	3320M-PSLH	TEFC	208-230/460	33	6
	86	20:1	2	326	GMP3344	977	DS	25	3320M-PSLH	TEFC	208-230/460	33	6
	173	10:1	2	164	GMP3348	977	DS	25	3320M-PSLH	TEFC	208-230/460	33	6

^(a) Vertical motor below gearhead not recommended.

Avoiding those positions where the high speed oil seal is immersed in oil, will provide greater security against high speed input seal wear.

^(b) See notes on inside back flap.

Input Motor Hp	Output RPM 60 Hz.	Gear Ratio	Speed Range	Maximum Safe Torque In-Lbs @ 60 Hz	Catalog Number	List Price	Mult. Sym.	Ap'x. Shpg. Wgt.	Motor Type & Gear Style	Volt Code
Inverter Duty Parallel Shaft										
3/8	55	30	8.0-82	350	IDGMP2505	742	E2	20	2528M-PS	C
	83	20	12-123	233	IDGMP2503	699	E2	20	2528M-PS	C
	165	10	23-246	116	IDGMP2501	699	E2	18	2528M-PS	C
	330	5	43-490	58	IDGMP2500	699	E2	18	2528M-PS	C

NOTE: Avoiding those positions where the high speed oil seal is immersed in oil, will provide greater security against seal wear.

Vertical motor below gearbox mounting is possible with modification, contact Baldor for details.

Voltage: @ 60 Hz: C = 230 volts

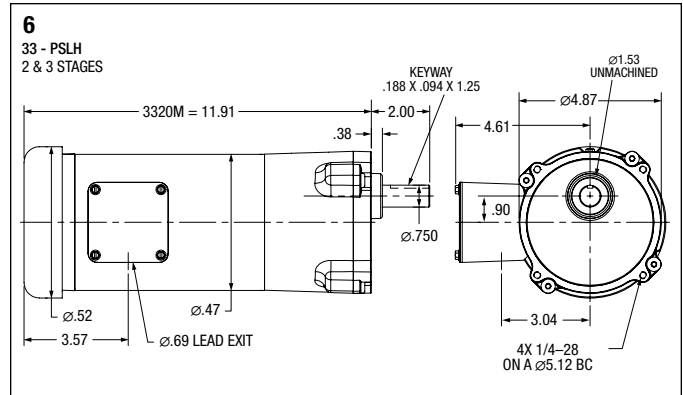
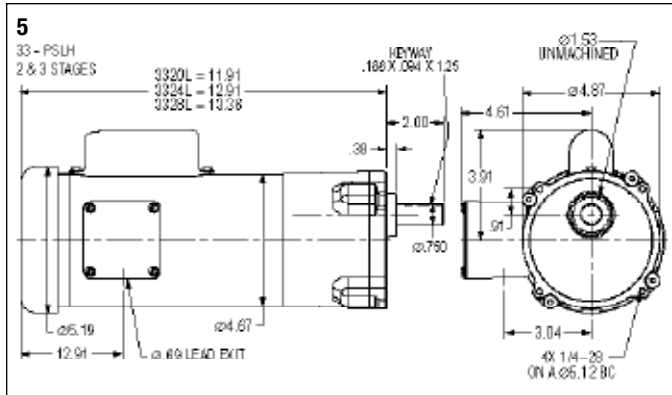
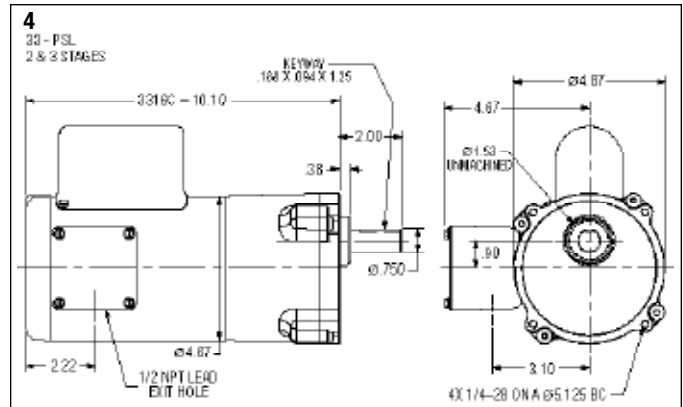
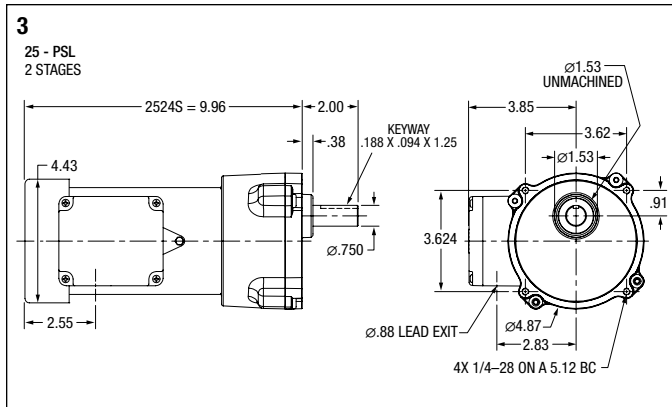
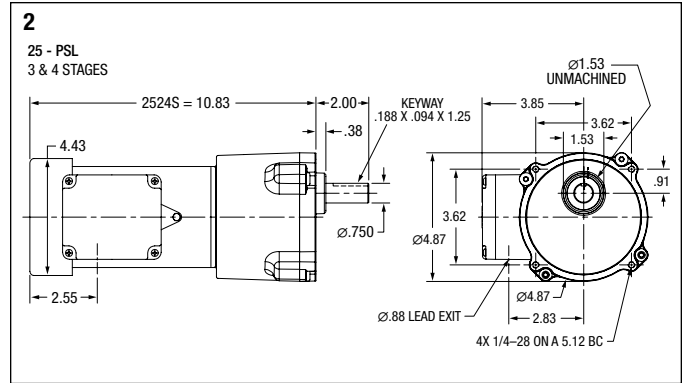
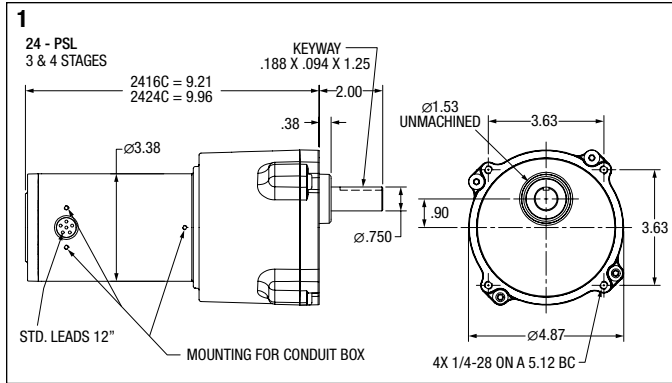

"L" Type Mounting Brackets



Applications: Mounting bracket for PSSH and PSL gear motors. Securely mounts to gear face in 90 degree locations for floor, wall or ceiling mount. Catalog LB74 is not recommended for PSL/PSLH units weighing over 20 lbs. For units weighing more than 20 lbs. use LB75.

Catalog Number	List Price	Mult. Sym.	Ap'x. Shpg. Wgt
LB73	49	A8	2
LB73GR	49	A8	2
LB74	69	A8	2
LB75	96	A8	7

NOTE: Painted Baldor gray. LB73 & LB73GR for PSSH style gearmotors, LB74 & LB75 for PSL/PSLH style gearmotors.



GP12505 Shown
PSSH Style

Applications: Conveyors, medical and laboratory equipment, printing presses, commercial ovens, machine tools and many other applications requiring adjustable speed.

Features: Induction hardened helical and spur gears for extra strength. Ball and needle-bearing construction for improved torque capacity. Factory lubricated for life, no maintenance required. PSSH is face mounted with industry standard dimensions. An optional bolt on base is available for foot mounting, see pages 292 and 327.

Input Motor Hp	Output Base Speed	Gear Ratio	Stages	Max. Safe Torque In. Lbs.	Catalog (a) Number	List Price	Mult. Sym.	Ap'x. Shpg. Wgt.	Motor Type & Gear Style	Voltage D.C. Armature	Full Load Amperage Armature	Notes (b)	Drawing Number
1/40	10	180:1	4	100	GPP230186	552	DS	8	2308P-PSSH	90	0.30	20	1
	13	135:1	4	100	GPP230139	552	DS	8	2308P-PSSH	90	0.30	20	1
1/45	9	180:1	4	100	GPP231108	542	DS	6	2308P-PSSH	90	0.29	20	1
1/21	19	90:1	4	118	GPP232110	542	DS	7	2314P-PSSH	90	0.57	20	1
1/50	29	60:1	3	40	GPP231109	514	DS	8	2308P-PSSH	90	0.35	20	2
1/20	25	75:1	3	100	GPP230072	608	DS	8	2318P-PSSH	90	0.70	20	1
	30	60:1	3	100	GPP233112	561	DS	8	2318P-PSSH	90	0.70	20	2
	49	37.95:1	3	55	GPP230037	572	DS	8	2318P-PSSH	90	0.70	20	1
	71	25:1	2	40	GPP230025	572	DS	8	2318P-PSSH	90	0.70	20	2
	95	20:1	2	30	GPP230019	537	DS	8	2318P-PSSH	90	0.70	20	2
	139	12.65:1	2	20	GPP230013	537	DS	8	2318P-PSSH	90	0.70	20	2
	185	10:1	2	15	GPP230010	537	DS	8	2318P-PSSH	90	0.70	20	2
	269	6.55:1	2	11	GPP230007	537	DS	8	2318P-PSSH	90	0.70	20	2
359	5:1	2	8	GPP230005	537	DS	8	2318P-PSSH	90	0.70	20	2	
1/17	60	30:1	3	50	GPP233111	561	DS	8	2318P-PSSH	90	0.65	20	2
1/35	120	20:1	2	9.5	GPP231110	514	DS	6	2308P-PSSH	90	0.36	20	2
1/12	43	60:1	3	112	GPP12505	623	DS	8	2412P-PSSH	90	1.00	20	3
	58	44:1	3	83	GPP12504	623	DS	8	2412P-PSSH	90	1.00	20	3
	125	20:1	2	38.5	GPP12502	593	DS	8	2412P-PSSH	90	1.00	20	3
	115	22:1	2	43	GPP12503	593	DS	8	2412P-PSSH	90	1.00	20	3
	250	10:1	2	19.7	GPP12501	593	DS	8	2412P-PSSH	90	1.00	20	3
1/22	19	90:1	4	118	GPP233120	561	DS	8	2314P-PSSH	180	0.30	20	1
1/12	43	40:1	3	112	GPP12525	600	DS	11	2420P-PSSH	180	0.45	20	3
1/20	60	30:1	3	50	GPP233121	561	DS	8	2318P-PSSH	180	0.35	20	2
1/12	250	10:1	2	19.7	GPP12521	600	DS	9	2416P-PSSH	180	0.49	20	3

(a) Vertical motor below gearhead not recommended. Avoiding those positions where the high speed oil seal is immersed in oil, will provide greater security against high speed input seal wear.

(b) See notes on inside back flap.

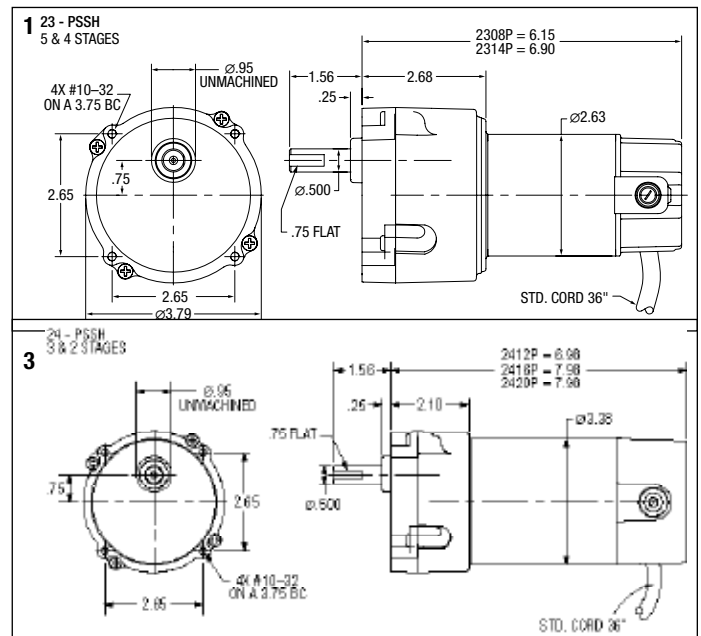
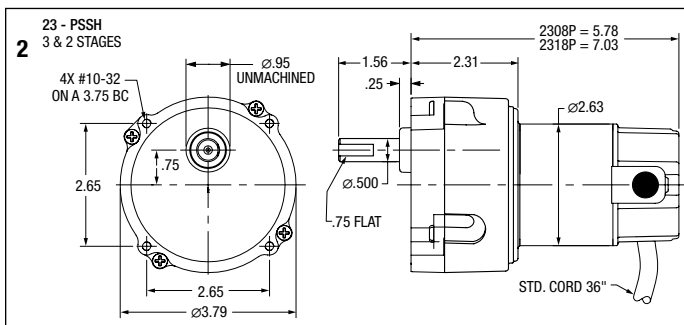



GPP233141 Shown
PSM Style

Applications: Conveyors, medical and laboratory equipment, printing presses, commercial ovens, machine tools and many other applications requiring adjustable speed.

Features: Induction hardened helical and spur gears for extra strength. Ball and needle-bearing construction for improved torque capacity. Factory lubricated for life, no maintenance required. PSM is face or foot mounted with industry standard dimensions. Optional bases are available for foot or 3-point face mounting, see pages 292 and 327.

Input Motor Hp	Output Base Speed	Gear Ratio	Stages	Max. Safe Torque In. Lbs.	Catalog Number ^(a)	List Price	Mult. Sym.	Ap'x. Shpg. Wgt.	Motor Type & Gear Style	Voltage D.C. Armature	Full Load Amperage Armature	Notes ^(b)	Drawing Number
1/20	34	52.9:1	3	85	GPP230053	637	DS	10	2318P-PSM	90	0.30	20	1
	7.5	329.1	4	183	GPP231329	675	DS	10	2318P-PSM	90	0.30	20	1
1/16	15.4	120:1	4	197	GPP233141	693	DS	8	2318P-PSM	90	0.66	20	1
1/15	18.6	90:1	4	180	GPP233140	693	DS	10	2318P-PSM	90	0.77	20	1
1/8	30	58.3:1	3	174	GPP12556	698	DS	12	2416P-PSM	90	1.35	20	2
	42	60:1	3	165	GPP12547	694	DS	12	2416P-PSM	90	1.35	20	2
	63	40:1	3	116	GPP12545	694	DS	12	2416P-PSM	90	1.35	20	2
	83	30:1	3	90	GPP12544	694	DS	12	2416P-PSM	90	1.35	20	2
1/8	94	19.1	2	76	GPP12559	714	DS	12	2416P-PSM	90	1.35	20	2
	125	20:1	2	58	GPP12543	663	DS	12	2416P-PSM	90	1.35	20	2
	167	15:1	2	45	GPP12542	663	DS	10	2416P-PSM	90	1.35	20	2
	360	5:1	2	20	GPP12555	714	DS	12	2416P-PSM	90	1.35	20	2
	250	10:1	2	30	GPP12541	663	DS	10	2416P-PSM	90	1.35	20	2
	500	5:1	2	15	GPP12540	663	DS	10	2416P-PSM	90	1.35	20	2
1/4	94	19.1:1	2	160	GPP24019	726	DS	14	2424P-PSM	90	2.50	20	2
	170	10.6:1	2	90	GPP24011	726	DS	14	2424P-PSM	90	2.50	20	2
	360	5:1	2	40	GPP24005	726	DS	14	2424P-PSM	90	2.50	20	2
1/8	42	60:1	3	174	GPP12567	670	DS	11	2416P-PSM	180	0.65	20	2
	83	30:1	3	87	GPP12564	670	DS	11	2416P-PSM	180	0.65	20	2
	250	10:1	2	30	GPP12561	663	DS	11	2416P-PSM	180	0.65	20	2
	500	5:1	2	14.8	GPP12560	663	DS	11	2416P-PSM	180	0.65	20	2

(a) Vertical motor below gearhead not recommended.
Avoiding those positions where the high speed oil seal is immersed in oil, will provide greater security against high speed input seal wear.

(b) See notes on inside back flap.

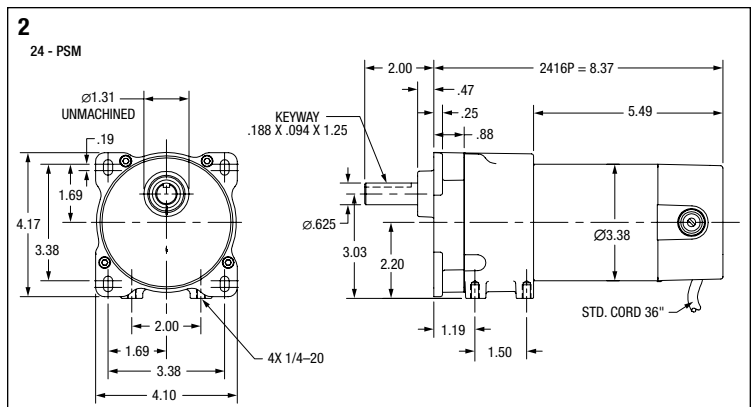
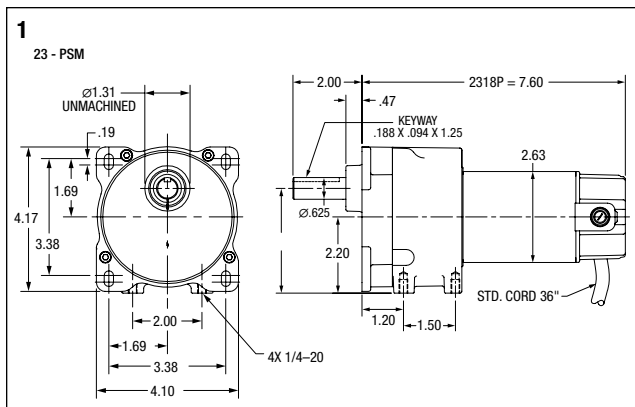



GPP7459 Shown
PSL Style

Applications: Conveyors, medical and laboratory equipment, printing presses, commercial ovens, machine tools and many other applications requiring adjustable speed.

Features: Induction hardened helical gears for added strength. Ball and needle-bearing construction for improved torque capacity. Factory lubricated for life, no maintenance required. PSL is face mounted with industry standard dimensions. An optional bolt on base is available for foot mounting. See pages 292 and 327.

Input Motor Hp	Output Base Speed	Gear Ratio	Stages	Max. Safe Torque In. Lbs.	Catalog Number ^(a)	List Price	Mult. Sym.	Ap'x. Shpg. Wgt.	Motor Type & Gear Style	Voltage D.C. Armature	Full Load Amperage Armature	Notes ^(b)	Drawing Number
1/8	8.3	300:1	4	330	GPP7459	875	DS	13	2416P-PSL	90	0.76	20	1
1/8	10.4	240:1	4	330	GPP7462	875	DS	13	2416P-PSL	90	0.71	20	1
1/4	14	180:1	4	365	GPP7458	875	DS	15	2424P-PSL	90	1.20	20	1
1/4	21	120:1	4	365	GPP7457	875	DS	15	2424P-PSL	90	1.70	20	1
1/4	28	90:1	4	390	GPP7461	875	DS	15	2424P-PSL	90	2.25	20	1
1/4	42	60:1	3	280	GPP7456	840	DS	14	2424P-PSL	90	2.50	20	1
1/4	50	50:1	3	250	GPP7460	840	DS	14	2424P-PSL	90	2.50	20	1
1/4	62	40:1	3	200	GPP7455	840	DS	14	2424P-PSL	90	2.50	20	1
1/4	83	30:1	3	150	GPP7454	840	DS	14	2424P-PSL	90	2.50	20	1
1/4	125	20:1	2	100	GPP7453	840	DS	13	2424P-PSL	90	2.50	20	2
1/4	165	15:1	2	75	GPP7452	772	DS	13	2424P-PSL	90	2.50	20	2
1/4	250	10:1	2	50	GPP7451	772	DS	13	2424P-PSL	90	2.50	20	2
1/4	500	5:1	2	25	GPP7450	772	DS	13	2424P-PSL	90	2.50	20	2
1/3	58	30:1	3	320	GPP2530	1,146	DS	24	2532P-PSLH	90	3.20	20	3
1/3	113	15:1	2	164	GPP2534	1,091	DS	24	2532P-PSLH	90	3.20	20	3
1/3	345	5:1	2	55	GPP2538	1,091	DS	24	2532P-PSLH	90	3.20	20	3
1/2	83	30:1	3	337	GPP3340	1,288	DS	31	3327P-PSLH	90	5.00	20	4
1/2	167	15:1	2	171	GPP3344	1,288	DS	31	3327P-PSLH	90	5.00	20	4
1/2	500	5:1	2	57	GPP3348	1,232	DS	31	3327P-PSLH	90	5.00	20	4
1/8	8.3	300:1	4	330	GPP7479	875	DS	14	2424P-PSL	180	0.38	20	1
1/4	14	180:1	4	365	GPP7478	875	DS	17	2424P-PSL	180	0.60	20	1
1/4	21	120:1	4	365	GPP7477	875	DS	15	2424P-PSL	180	0.85	20	1
1/4	42	60:1	3	280	GPP7476	840	DS	14	2424P-PSL	180	1.25	20	1
1/4	62	40:1	3	200	GPP7475	840	DS	14	2424P-PSL	180	1.25	20	1
1/4	83	30:1	3	155	GPP7474	840	DS	14	2424P-PSL	180	1.25	20	1
1/4	125	20:1	2	100	GPP7473	840	DS	13	2424P-PSL	180	1.25	20	2
1/4	165	15:1	2	75	GPP7472	772	DS	13	2424P-PSL	180	1.25	20	2
1/4	250	10:1	2	50	GPP7471	772	DS	13	2424P-PSL	180	1.25	20	2
1/4	500	5:1	2	25	GPP7470	772	DS	13	2424P-PSL	180	1.25	20	2
1/3	58	30:1	3	320	GPP3370	1,288	DS	31	3327P-PSLH	180	1.50	20	4
1/3	115	15:1	2	164	GPP3374	1,232	DS	31	3327P-PSLH	180	1.50	20	4
1/3	345	5:1	2	55	GPP3378	1,232	DS	31	3327P-PSLH	180	1.60	20	4
1/2	83	30:1	3	337	GPP3380	1,288	DS	31	3327P-PSLH	180	2.50	20	4
1/2	167	15:1	2	171	GPP3384	1,232	DS	31	3327P-PSLH	180	2.50	20	4
1/2	500	5:1	2	57	GPP3388	1,232	DS	31	3327P-PSLH	180	2.50	20	4

(a) Vertical motor below gearhead not recommended.

Avoiding those positions where the high speed oil seal is immersed in oil, will provide greater security against high speed input seal wear.

(b) See notes on inside back flap.

1 24 - PSL
3 & 4 STAGES

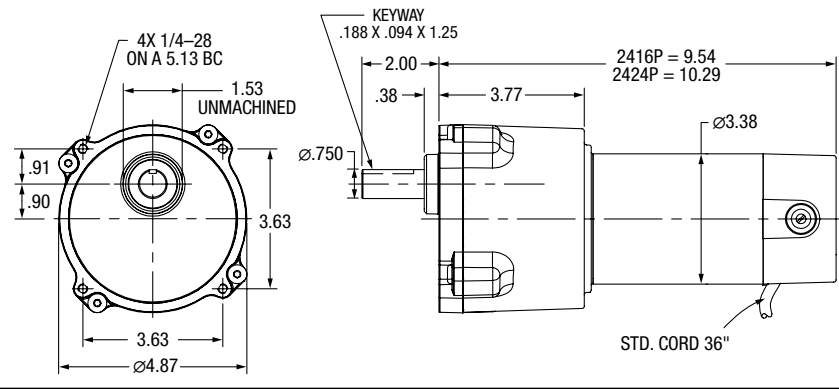

2 24 - PSL
2 STAGES

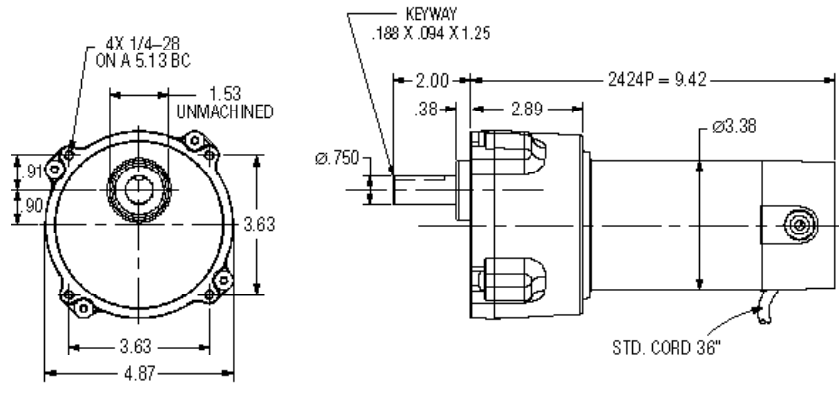

3 25 - PSLH
3 & 2 STAGES

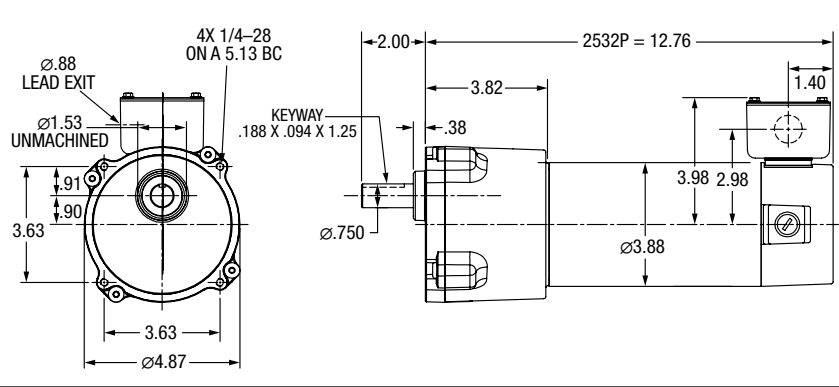

4 33 - PSLH
2 & 3 STAGES

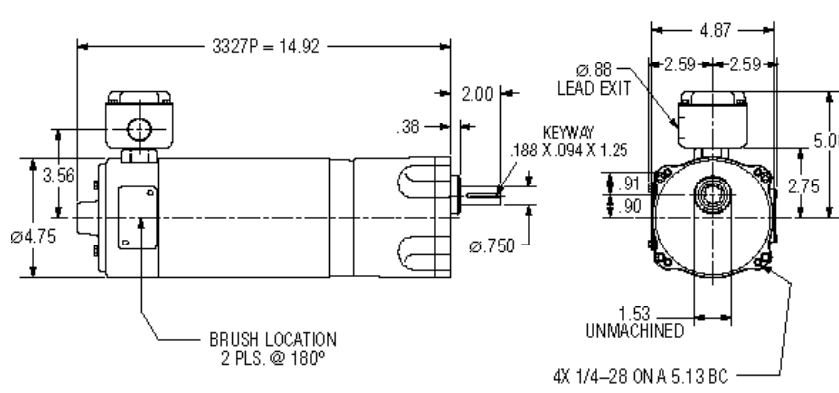

900 Series – Right Angle – Quill Type Solid Shaft

1.33 thru 3.75 CD

NEMA 56C thru 210TC

Applications: Ideal for conveyors, material handling, textile machines, packaging machinery. etc. (slow speed and high torque).

Features: Heavy duty cast iron housing, chill cast bronze gearing, precision ground hardened worm, ball bearing on input shaft, tapered roller bearings on output shaft. Industry-standard mounting dimensions. Pre-filled with food grade (H1) Klubersynth UH1-6-460 synthetic oil, sealed housing provides maintenance-free lubed for life operation.



Nominal Output RPM @ 1750 RPM In	Gear Ratio	Continuous Duty Output Torque (In-Lbs) Based on 1750 RPM Motor										Max Input Hp	Max Output Torque Rating In-Lbs	NEMA Motor Mount	Style Number	Catalog Number	List Price	Mult. Sym.	Ap'x Shpg. Wgt.		
		0.25	0.33	0.5	0.75	1	1.5	2	3	5	7.5									10	
350	5:1		75	112	149								1.11	165	56C	F-913-05-B5-G	GF0513AG	504	GB	20	
			75	112	149									1.11	165	56C	F-913-05-B5-J	GF0513AJ	504	GB	20
				115	154	231								1.50	231	56C	F-915-05-B5-G	GF0515AG	539	GB	25
				115	154	231								1.50	231	140TC	F-915-05-B7-G	GF0515BG	539	GB	25
				115	154	231								1.50	231	56C	F-915-05-B5-H	GF0515AH	571	GB	25
					160	240	320							2.00	320	56C	F-918-05-B5-G	GF0518AG	552	GB	30
					160	240	320							2.00	320	140TC	F-918-05-B7-G	GF0518BG	552	GB	30
						246	327	491						3.14	514	140TC	F-921-05-B7-G	GF0521BG	691	GB	35
						246	327	491						3.14	514	140TC	F-921-05-B7-J	GF0521BJ	691	GB	35
							339	507						4.17	705	180TC	F-924-05-B9-G	GF0524CG	815	GB	49
							339	508	847					5.43	919	180TC	F-926-05-B9-G	GF0526CG	945	GB	59
								502	837	1255				7.64	1279	180TC	F-930-05-B9-G	GF0530CG	1,285	GB	68
							837	1255	1674			13.7	2315	210TC	F-938-05-B11-H	GF0538DH	1,798	GB	123		
175	10:1		82	125	187								0.90	225	56C	F-913-10-B5-G	GF1013AG	504	GB	20	
			82	125	187									0.90	225	56C	F-913-10-B5-J	GF1013AJ	504	GB	20
			82	125	187									0.90	225	56C	F-913-10-B5-H	GF1013AH	533	GB	20
				141	211	282								1.03	290	56C	F-915-10-B5-G	GF1015AG	539	GB	26
				141	211	282								1.03	290	140TC	F-915-10-B7-G	GF1015BG	539	GB	20
				141	211	282								1.03	290	56C	F-915-10-B5-H	GF1015AH	571	GB	25
					214	285	428							1.50	428	56C	F-918-10-B5-G	GF1018AG	552	GB	30
					214	285	428							1.50	428	56C	F-918-10-B5-J	GF1018AJ	552	GB	30
					214	285	428							1.50	428	56C	F-918-10-B5-H	GF1018AH	585	GB	29
						214	285	428						1.50	428	140TC	F-918-10-B7-G	GF1018BG	552	GB	30
						312	468	624						2.02	630	56C	F-921-10-B5-G	GF1021AG	691	GB	35
						312	468	624						2.02	630	56C	F-921-10-B5-J	GF1021AJ	691	GB	35
				312	468	624						2.02	630	56C	F-921G-10-B5-G	GF10G21AG	691	GB	30		

NOTE: Service Class I Torque Ratings (1.0 Service Factor)
 Service Class II Torque Ratings (≥ 1.4 Service Factor)
 Service Class III Torque Ratings (≥ 2.0 Service Factor)

Vertical motor below gearhead not recommended.
 Avoiding those positions where the high speed oil seal is immersed in oil, will provide greater security against high speed input seal wear.
 Replacement oil – 1 Qt P/N MJ0006A05SP (Klubersynth UH1-6-460)

Assembly Types

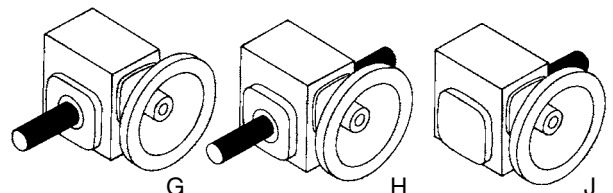

Gearmotors and Gear Products

Motor Accessories

PT Components

Grinders

Baldor Mod Express

ABB Mod Express

Product Index

900 Series - Right Angle - Quill Type - Solid Shaft continued...

Nominal Output RPM @ 1750 RPM In	Gear Ratio	Continuous Duty Output Torque (In-Lbs) Based on 1750 RPM Motor									Max Input Hp	Max Output Torque Rating In-Lbs	NEMA Motor Mount	Style Number	Catalog Number	List Price	Mult. Sym.	Ap'x Shpg. Wgt.		
		0.25	0.33	0.5	0.75	1	1.5	2	3	5									7.5	
175	10:1					312	468	624				2.02	630	56C	F-921-10-B5-H	GF1021AH	728	GB	35	
						312	468	624				2.02	630	140TC	F-921-10-B7-G	GF1021BG	691	GB	35	
						317	475	634				2.73	893	140TC	F-924-10-B7-G	GF1024BG	815	GB	40	
									655	983			3.59	1177	140TC	F-926-10-B7-G	GF1026BG	945	GB	52
									655	983			3.59	1177	180TC	F-926-10-B9-G	GF1026CG	945	GB	60
								641	961	1602			5.48	1755	180TC	F-930-10-B9-G	GF1030CG	1,285	GB	72
										990	1649		6.36	2106	180TC	F-932-10-B9-G	GF1032CG	1,393	GB	97
117	15:1		89	118	179							0.66	225	56C	F-913-15-B5-G	GF1513AG	504	GB	20	
			89	118	179							0.66	225	56C	F-913-15-B5-J	GF1513AJ	504	GB	20	
			89	118	179							0.66	225	56C	F-913-15-B5-H	GF1513AH	533	GB	20	
				127	193	289						0.81	312	56C	F-915-15-B5-G	GF1515AG	539	GB	25	
				127	193	289						0.81	312	56C	F-915-15-B5-H	GF1515AH	571	GB	25	
					209	314	419					1.07	448	56C	F-918-15-B5-G	GF1518AG	552	GB	30	
					209	314	419					1.07	448	56C	F-918-15-B5-J	GF1518AJ	552	GB	30	
					209	314	419					1.07	448	56C	F-918-15-B5-H	GF1518AH	585	GB	30	
					246	369	492					1.35	664	56C	F-921-15-B5-G	GF1521AG	691	GB	35	
					246	369	492					1.35	664	56C	F-921-15-B5-J	GF1521AJ	691	GB	35	
					246	369	492					1.35	664	56C	F-921-15-B5-H	GF1521AH	728	GB	35	
					246	369	492					1.35	664	140TC	F-921-15-B7-G	GF1521BG	691	GB	35	
						470	705	939				2.11	992	56C	F-924-15-B5-G	GF1524AG	815	GB	40	
						470	705	939				2.11	992	56C	F-924-15-B5-J	GF1524AJ	815	GB	40	
						470	705	939				2.11	992	140TC	F-924-15-B7-G	GF1524BG	815	GB	40	
						473	710	947				2.58	1225	140TC	F-926-15-B7-G	GF1526BG	945	GB	55	
							686	915	1373			4.14	1903	180TC	F-930-15-B9-G	GF1530CG	1,285	GB	68	
								959	1438			4.66	2241	140TC	F-932-15-B7-G	GF1532BG	1,393	GB	87	
								959	1438			4.66	2241	180TC	F-932-15-B9-G	GF1532CG	1,393	GB	97	
									1409	2349		6.64	3118	180TC	F-938-15-B9-G	GF1538CG	1,701	GB	119	
88	20:1		113	149	226							0.53	239	56C	F-913-20-B5-G	GF2013AG	504	GB	20	
			113	149	226							0.53	239	56C	F-913-20-B5-H	GF2013AH	533	GB	20	
			128	169	256							0.62	317	56C	F-915-20-B5-G	GF2015AG	539	GB	25	
			128	169	256							0.62	317	56C	F-915-20-B5-H	GF2015AH	571	GB	25	
				165	251	376						0.92	461	56C	F-918-20-B5-G	GF2018AG	552	GB	30	
				165	251	376						0.92	461	56C	F-918-20-B5-J	GF2018AJ	552	GB	30	
				165	251	376						0.92	461	56C	F-918-20-B5-H	GF2018AH	585	GB	30	
					323	484	645					1.06	684	56C	F-921-20-B5-G	GF2021AG	691	GB	35	
					323	484	645					1.06	684	56C	F-921-20-B5-J	GF2021AJ	691	GB	35	
					323	484	645					1.06	684	56C	F-921G-20-B5-G	GF20G21AG	691	GB	35	

NOTE: Service Class I Torque Ratings (1.0 Service Factor)
 Service Class II Torque Ratings (≥ 1.4 Service Factor)
 Service Class III Torque Ratings (≥ 2.0 Service Factor)

See notes on inside back flap.

Vertical motor below gearhead not recommended. Avoiding those positions where the high speed oil seal is immersed in oil, will provide greater security against high speed input seal wear.

Assembly Types

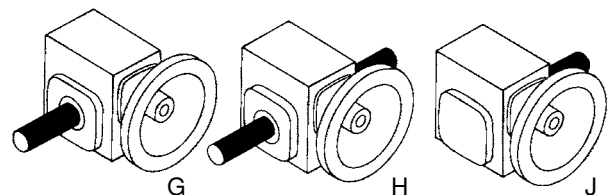

900 Series – Right Angle – Quill Type – Solid Shaft continued...

Nominal Output RPM @ 1750 RPM In	Gear Ratio	Continuous Duty Output Torque (In-Lbs) Based on 1750 RPM Motor									Max Input Hp	Max Output Torque Rating In-Lbs	NEMA Motor Mount	Style Number	Catalog Number	List Price	Mult. Sym.	Ap'x Shpg. Wgt.		
		0.25	0.33	0.5	0.75	1	1.5	2	3	5									7.5	
88	20:1			323	484	645						1.06	684	56C	F-921-20-B5-H	GF2021AH	728	GB	35	
				323	484	645							1.06	684	140TC	F-921-20-B7-G	GF2021BG	691	GB	35
				323	484	645							1.06	684	140TC	F-921G-20-B7-G	GF20G21BG	691	GB	30
					451	602	902						1.72	1038	56C	F-924-20-B5-G	GF2024AG	815	GB	40
					451	602	902						1.72	1038	140TC	F-924-20-B7-G	GF2024BG	815	GB	40
						609	913	1218					2.15	1308	56C	F-926-20-B5-G	GF2026AG	945	GB	55
						609	913	1218					2.15	1308	140TC	F-926-20-B7-G	GF2026BG	945	GB	52
							880	1174	1761				3.31	1955	140TC	F-930-20-B7-G	GF2030BG	1,285	GB	68
							880	1174	1761				3.31	1955	180TC	F-930-20-B9-G	GF2030CG	1,285	GB	68
							880	1174	1761				3.31	1955	180TC	F-930-20-B9-J	GF2030CJ	1,285	GB	68
							924	1232	1848				3.85	2383	140TC	F-932-20-B7-G	GF2032BG	1,393	GB	87
							924	1232	1848				3.85	2383	180TC	F-932-20-B9-G	GF2032CG	1,393	GB	97
						1176	1764	2940			5.43	3193	180TC	F-938-20-B9-G	GF2038CG	1,701	GB	120		
70	25:1	119	157	238							0.50	238	56C	F-913-25-B5-G	GF2513AG	504	GB	20		
		156	206	312								0.51	318	56C	F-915-25-B5-G	GF2515AG	539	GB	25	
		156	206	312								0.51	318	56C	F-915-25-B5-H	GF2515AH	571	GB	25	
			183	277	416							0.8	444	56C	F-918-25-B5-G	GF2518AG	552	GB	28	
			183	277	416							0.8	444	56C	F-918-25-B5-J	GF2518AJ	552	GB	30	
			250	379	569							0.89	675	56C	F-921-25-B5-G	GF2521AG	691	GB	35	
			250	379	569							0.89	675	56C	F-921-25-B5-J	GF2521AJ	691	GB	35	
			250	379	569							0.89	675	56C	F-921G-25-B5-G	GF25G21AG	691	GB	40	
				365	547	729						1.37	1002	56C	F-924-25-B5-G	GF2524AG	815	GB	36	
				365	547	729						1.37	1002	140TC	F-924-25-B7-G	GF2524BG	815	GB	40	
					567	756	1134					1.73	1307	140TC	F-926-25-B7-G	GF2526BG	945	GB	52	
						711	1066	1422				2.78	1978	56C	F-930-25-B5-G	GF2530AG	1,285	GB	68	
						711	1066	1422				2.78	1978	140TC	F-930-25-B7-G	GF2530BG	1,285	GB	68	
							1134	1513	2269			3.13	2355	140TC	F-932-25-B7-G	GF2532BG	1,393	GB	91	
								1440	2160			4.50	3222	180TC	F-938-25-B9-H	GF2538CH	1,798	GB	126	
58	30:1	148	195								0.42	248	56C	F-913-30-B5-G	GF3013AG	504	GB	20		
		148	195								0.42	248	56C	F-913-30-B5-H	GF3013AH	533	GB	20		
		159	210	318								0.50	318	56C	F-915-30-B5-G	GF3015AG	539	GB	25	
		159	210	318								0.50	318	56C	F-915-30-B5-H	GF3015AH	571	GB	25	
			216	327								0.72	470	56C	F-918-30-B5-G	GF3018AG	552	GB	30	
			216	327								0.72	470	56C	F-918-30-B5-J	GF3018AJ	552	GB	30	
			216	327								0.72	470	56C	F-918-30-B5-H	GF3018AH	585	GB	30	
			275	416	624							0.83	691	56C	F-921-30-B5-G	GF3021AG	691	GB	35	
			275	416	624							0.83	691	56C	F-921-30-B5-J	GF3021AJ	691	GB	35	
			275	416	624							0.83	691	56C	F-921-30-B5-H	GF3021AH	728	GB	35	
			275	416	624							0.83	691	56C	F-921G-30-B5-G	GF30G21AG	691	GB	30	
				420	630	840						1.32	1111	56C	F-924-30-B5-G	GF3024AG	815	GB	40	
				420	630	840						1.32	1111	56C	F-924-30-B5-J	GF3024AJ	815	GB	40	
				420	630	840						1.32	1111	140TC	F-924-30-B7-G	GF3024BG	815	GB	40	
					641	854	1281					1.54	1313	56C	F-926-30-B5-G	GF3026AG	945	GB	52	
					641	854	1281					1.54	1313	140TC	F-926-30-B7-G	GF3026BG	945	GB	55	
						804	1206	1608				2.47	1978	56C	F-930-30-B5-G	GF3030AG	1,285	GB	68	
						804	1206	1608				2.47	1978	56C	F-930-30-B5-J	GF3030AJ	1,285	GB	68	
						804	1206	1608				2.47	1978	140TC	F-930-30-B7-G	GF3030BG	1,285	GB	65	
						881	1322	1763				2.81	2482	140TC	F-932-30-B7-G	GF3032BG	1,393	GB	91	
							1626	2438				3.97	3226	180TC	F-938-30-B9-G	GF3038CG	1,701	GB	126	

NOTE: Refer to Brochure CA1600 for Dimensions and Engineering Information.

See notes on inside back flap.

- Service Class I Torque Ratings (1.0 Service Factor)
- Service Class II Torque Ratings (≥ 1.4 Service Factor)
- Service Class III Torque Ratings (≥ 2.0 Service Factor)

Vertical motor below gearhead not recommended.

Avoiding those positions where the high speed oil seal is immersed in oil, will provide greater security against high speed input seal wear.

Gearmotors and Gear Products

Motor Accessories

PT Components

Grinders

Baldor Mod Express

ABB Mod Express

Product Index

900 Series – Right Angle – Quill Type – Solid Shaft continued...

Nominal Output RPM @ 1750 RPM In	Gear Ratio	Continuous Duty Output Torque (In-Lbs) Based on 1750 RPM Motor										Max Input Hp	Max Output Torque Rating In-Lbs	NEMA Motor Mount	Style Number	Catalog Number	List Price	Mult. Sym.	Ap'x Shpg. Wgt.	
		0.25	0.33	0.5	0.75	1	1.5	2	3	5	7.5									
44	40:1	174	230									0.33	230	56C	F-913-40-BG-G	GF4013AG	504	GB	20	
		174	230									0.33	230	56C	F-913-40-B5-H	GF4013AH	533	GB	20	
		208	275									0.38	317	56C	F-915-40-B5-G	GF4015AG	539	GB	25	
		208	275									0.38	317	56C	F-915-40-B5-J	GF4015AJ	539	GB	25	
		180	238	360								0.64	461	56C	F-918-40-B5-G	GF4018AG	552	GB	30	
		180	238	360								0.64	461	56C	F-918-40-B5-J	GF4018AJ	552	GB	30	
			340	515								0.66	680	56C	F-921-40-B5-G	GF4021AG	691	GB	35	
			340	515								0.66	680	56C	F-921-40-B5-J	GF4021AJ	691	GB	35	
				521	781							0.99	1030	56C	F-924-40-B5-G	GF4024AG	815	GB	40	
				521	781							0.99	1030	56C	F-924-40-B5-J	GF4024AJ	815	GB	40	
				521	781							0.99	1030	56C	F-924-40-B5-H	GF4024AH	861	GB	40	
				524	786	1049						1.23	1296	56C	F-926-40-B5-G	GF4026AG	945	GB	55	
				524	786	1049						1.23	1296	56C	F-926-40-B5-J	GF4026AJ	945	GB	52	
				524	786	1049						1.23	1296	140TC	F-926-40-B7-G	GF4026BG	945	GB	55	
					794	1059	1589					1.84	1960	56C	F-930-40-B5-G	GF4030AG	1,285	GB	68	
					794	1059	1589					1.84	1960	140TC	F-930-40-B7-G	GF4030BG	1,285	GB	68	
		35	50:1					1180	1620	2160			2.20	2374	140TC	F-932-40-B7-G	GF4032BG	1,393	GB	88
									1596	2129	3192			3.00	3192	180TC	F-938-40-B9-G	GF4038CG	1,701	GB
							1596	2129	3192			3.00	3192	180TC	F-938-40-B9-H	GF4038CH	1,798	GB	126	
177	234											0.33	234	56C	F-913-50-B5-G	GF5013AG	504	GB	20	
177	234											0.33	234	56C	F-913-50-B5-H	GF5013AH	533	GB	20	
230	303											0.33	303	56C	F-915-50-B5-G	GF5015AG	539	GB	25	
222	294											0.49	436	56C	F-918-50-B5-G	GF5018AG	552	GB	30	
222	294											0.49	436	56C	F-918-50-B5-J	GF5018AJ	552	GB	30	
280	370			561								0.58	651	56C	F-921-50-B5-G	GF5021AG	691	GB	35	
280	370			561								0.58	651	56C	F-921-50-B5-J	GF5021AJ	691	GB	35	
280	370			561								0.58	651	56C	F-921-50-B5-H	GF5021AH	728	GB	35	
	401			608	912							0.83	1014	56C	F-924-50-B5-G	GF5024AG	815	GB	40	
				621	932	1242						1.00	1242	56C	F-926-50-B5-G	GF5026AG	945	GB	55	
				621	932	1242						1.00	1242	140TC	F-926-50-B7-G	GF5026BG	945	GB	52	
					850	1134	1701					1.67	1890	56C	F-930-50-B5-G	GF5030AG	1,285	GB	68	
					850	1134	1701					1.67	1890	140TC	F-930-50-B7-G	GF5030BG	1,285	GB	68	
29	60:1												1.83	2366	56C	F-932-50-B5-G	GF5032AG	1,393	GB	87
													1.83	2366	140TC	F-932-50-B7-G	GF5032BG	1,393	GB	87
											2.67	3076	140TC	F-938-50-B7-G	GF5038BG	1,701	GB	117		
											2.67	3076	140TC	F-938-50-B7-H	GF5038BH	1,798	GB	126		
		218	288									0.33	288	56C	F-915-60-B5-G	GF6015AG	539	GB	25	
		218	288									0.33	288	56C	F-915-60-B5-H	GF6015AH	571	GB	25	
		220	290									0.47	413	56C	F-918-60-B5-G	GF6018AG	552	GB	30	
		220	290									0.47	413	56C	F-918-60-B5-J	GF6018AJ	552	GB	30	
		220	290									0.47	413	56C	F-918-60-B5-H	GF6018AH	585	GB	30	

NOTE: Service Class I Torque Ratings (1.0 Service Factor)
 Service Class II Torque Ratings (≥ 1.4 Service Factor)
 Service Class III Torque Ratings (≥ 2.0 Service Factor)

See notes on inside back flap.

Vertical motor below gearhead not recommended.
 Avoiding those positions where the high speed oil seal is immersed in oil, will provide greater security against high speed input seal wear.

900 Series – Right Angle – Quill Type – Solid Shaft continued...

Nominal Output RPM @ 1750 RPM In	Gear Ratio	Continuous Duty Output Torque (In-Lbs) Based on 1750 RPM Motor										Max Input Hp	Max Output Torque Rating In-Lbs	NEMA Motor Mount	Style Number	Catalog Number	List Price	Mult. Sym.	Ap'x Shpg. Wgt.	
		0.25	0.33	0.5	0.75	1	1.5	2	3	5	7.5									
29	60:1	317	418	634								0.50	634	56C	F-921-60-B5-G	GF6021AG	691	GB	35	
		317	418	634								0.50	634	56C	F-921-60-B5-H	GF6021AH	728	GB	35	
		317	418	634								0.50	634	56C	F-921-60-B5-J	GF6021AJ	691	GB	35	
			458	693								0.69	958	56C	F-924-60-B5-G	GF6024AG	815	GB	40	
			458	693								0.69	958	56C	F-924-60-B5-J	GF6024AJ	815	GB	40	
			473	716	1074							0.82	1166	56C	F-926-60-B5-G	GF6026AG	945	GB	55	
			473	716	1074							0.82	1166	56C	F-926-60-B5-J	GF6026AJ	945	GB	55	
			473	716	1074							0.82	1166	56C	F-926-60-B5-H	GF6026AH	996	GB	55	
					896	1195	1795						1.50	1795	56C	F-930-60-B5-G	GF6030AG	1,285	GB	68
					896	1195	1795						1.50	1795	140TC	F-930-60-B7-G	GF6030BG	1,285	GB	68
					1100	1467	2200						1.54	2255	56C	F-932-60-B5-G	GF6032AG	1,393	GB	90
					1100	1467	2200						1.54	2255	140TC	F-932-60-B7-G	GF6032BG	1,393	GB	91
						1254	1881	2508					2.33	2921	140TC	F-938-60-B7-G	GF6038BG	1,701	GB	117
						1254	1881	2508					2.33	2921	140TC	F-938-60-B7-H	GF6038BH	1,798	GB	126

NOTE: Service Class I Torque Ratings (1.0 Service Factor) See notes on inside back flap.
 Service Class II Torque Ratings (≥ 1.4 Service Factor)
 Service Class III Torque Ratings (≥ 2.0 Service Factor)

Suffix G = Left hand output facing input
 J = Right hand output facing input
 H = Double Output Shaft

Vertical motor below gearhead not recommended.
 Avoiding those positions where the high speed oil seal is immersed in oil, will provide greater security against high speed input seal wear.

Assembly Types

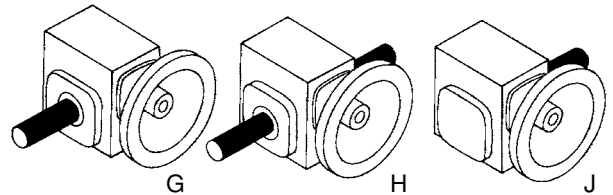

Gearmotors and Gear Products

Motor Accessories

PT Components

Grinders

Baldor Mod Express

ABB Mod Express

Product Index

900 Series – Right Angle – Quill Type Hollow Shaft



1.33 thru 3.25 CD

56C thru 180TC

Applications: Ideal for conveyors, material handling, textile machines, packaging machinery. etc. (slow speed and high torque).

Features: Heavy duty cast iron housing, chill cast bronze gearing, precision ground hardened worm, ball bearing on input shaft, tapered roller bearings on output shaft. Industry-standard mounting dimensions. Pre-filled with food grade (H1) Klubersynth UH1-6-460 synthetic oil, sealed housing provides maintenance-free lubed for life operation.

Nominal Output RPM @ 1750 RPM In	Gear Ratio	Continuous Duty Output Torque (In-Lbs) Based on 1750 RPM Motor										Max Input Hp	Max Output Torque Rating In-Lbs	NEMA Motor Mount	Style Number	Catalog Number	List Price	Mult. Sym.	Ap'x Shpg. Wgt.
		0.25	0.33	0.5	0.75	1	1.5	2	3	5	7.5								
350	5:1		75	112	149							1.00	165	56C	HF-913-05-B5-H	GHF0513AH	664	GB	20
						160	240	320				2.00	320	56C	HF-918-05-B5-H	GHF0518AH	710	GB	30
175	10:1			214	285	428						1.50	428	56C	HF-918-10-B5-H	GHF1018AH	710	GB	30
						312	468	624				2.02	630	56C	HF-921-10-B5-H	GHF1021AH	842	GB	35
								641	961	1602		5.48	1755	180TC	HF-930-10-B9-H	GHF1030CH	1,527	GB	75
117	15:1	89	118	179								0.66	25	56C	HF-913-15-B5-H	GHF1513AH	664	GB	20
				209	314	419						1.07	448	56C	HF-918-15-B5-H	GHF1518AH	710	GB	30
				246	369	492						1.35	664	56C	HF-921-15-B5-H	GHF1521AH	842	GB	35
						470	705	939				2.11	992	56C	HF-924-15-B5-H	GHF1524AH	1,013	GB	45
							686	915	1373			4.14	1903	140TC	HF-930-15-B7-H	GHF1530BH	1,527	GB	75
88	20:1	113	149	226								0.53	239	56C	HF-913-20-B5-H	GHF2013AH	664	GB	20
			165	251	376							0.92	461	56C	HF-918-20-B5-H	GHF2018AH	710	GB	30
				323	484	645						1.06	684	56C	HF-921-20-B5-H	GHF2021AH	842	GB	35
					451	602	902					1.72	1038	56C	HF-924-20-B5-H	GHF2024AH	1,013	GB	42
						609	913	1218				2.15	1309	56C	HF-926-20-B5-H	GHF2026AH	1,195	GB	56
							880	1174	1761			3.31	1955	140TC	HF-930-20-B7-H	GHF2030BH	1,527	GB	72
70	25		183	277	416							0.80	444	56C	HF-918-25-B5-H	GHF2518AH	710	GB	23
			250	379	569							0.89	675	56C	HF-921-25-B5-H	GHF2521AH	842	GB	32
					567	756	1134					1.73	1307	140TC	HF-926-25-B7-H	GHF2526BH	1,195	GB	56
						711	1066	1422				2.78	1978	140TC	HF-930-25-B7-H	GHF2530BH	1,527	GB	88
58	30:1	148	195									0.42	248	56C	HF-913-30-B5-H	GHF3013AH	664	GB	20
			216	327								0.72	470	56C	HF-918-30-B5-H	GHF3018AH	710	GB	30
			275	416	624							0.83	691	56C	HF-921-30-B5-H	GHF3021AH	842	GB	35
				420	630	840						1.32	1111	56C	HF-924-30-B5-H	GHF3024AH	1,013	GB	45
					641	854	1281					1.54	1313	56C	HF-926-30-B5-H	GHF3026AH	1,195	GB	56
						804	1206	1608				2.47	1978	140TC	HF-930-30-B7-H	GHF3030BH	1,527	GB	75
						881	1322	1763				2.81	2462	140TC	HF-932-30-B7-H	GHF3032BH	1,655	GB	95
44	40:1	180	238	360								0.64	461	56C	HF-918-40-B5-H	GHF4018AH	710	GB	30
			340	515								0.66	680	56C	HF-921-40-B5-H	GHF4021AH	842	GB	35
				521	781							0.99	1030	56C	HF-924-40-B5-H	GHF4024AH	1,013	GB	42
				524	786	1049						1.23	1296	56C	HF-926-40-B5-H	GHF4026AH	1,195	GB	56
				524	786	1049						1.23	1296	140TC	HF-926-40-B7-H	GHF4026BH	1,195	GB	56
						1074	1611	2148				2.20	2374	140TC	HF-932-40-B7-H	GHF4032BH	1,655	GB	95
35	50:1	177	234									0.33	234	56C	HF-913-50-B5-H	GHF5013AH	664	GB	20
			222	294								0.49	436	56C	HF-918-50-B5-H	GHF5018AH	710	GB	30
			280	370	561							0.58	651	56C	HF-921-50-B5-H	GHF5021AH	842	GB	35
				401	608	912						0.83	1014	56C	HF-924-50-B5-H	GHF5024AH	1,013	GB	45
					850	1134	1701					1.67	1890	56C	HF-930-50-B5-H	GHF5030AH	1,527	GB	75
					958	1278	1917					1.83	2366	56C	HF-932-50-B5-H	GHF5032AH	1,655	GB	95
29	60:1	220	290									0.47	413	56C	HF-918-60-B5-H	GHF6018AH	710	GB	30
			317	418	634							0.50	634	56C	HF-921-60-B5-H	GHF6021AH	842	GB	35
				458	693							0.69	958	56C	HF-924-60-B5-H	GHF6024AH	1,013	GB	42
				473	716	1074						0.82	1166	56C	HF-926-60-B5-H	GHF6026AH	1,195	GB	56
					896	1195	1795					1.50	1795	56C	HF-930-60-B5-H	GHF6030AH	1,527	GB	71
					1100	1467	2200					1.54	2255	56C	HF-932-60-B5-H	GHF6032AH	1,655	GB	92

NOTE: Service Class I Torque Ratings (1.0 Service Factor)
 Service Class II Torque Ratings (≥ 1.4 Service Factor)
 Service Class III Torque Ratings (≥ 2.0 Service Factor)

See notes on inside back flap.

Vertical motor below gearhead not recommended

Avoiding those positions where the high speed oil seal is immersed in oil, will provide greater security against high speed input seal wear.

**Stainless Steel –
Right Angle – Quill
Type Solid Shaft**



1.75 thru 2.62 CD

56C thru 140TC

Applications: Baldor's all stainless speed reducers are easy to clean and sanitize, minimizing bacterial contamination for food processing equipment. Stainless steel provides the high protection for pharmaceutical and chemical processing applications where harsh chemicals and cleaning solutions can be extremely corrosive to aluminum, cast iron and other materials.

Features: Housing and covers are cast stainless steel to endure hostile environments. 300 Series stainless output shafts and all stainless steel hardware for long rust resistant life. O-ring sealed housing and motor interface helps keeps contaminants out. Pre-filled with food grade (H1) Klubersynth UH1-6-460 synthetic oil. Sealed housing provides maintenance-free lubed for life operation. BISSC certified (Baking Industry Sanitation Standards Committee).

Nominal Output RPM @ 1750 RPM In	Gear Ratio	Continuous Duty Output Torque (In-Lbs) Based on 1750 RPM Motor									Max Input Hp	Max Output Torque Rating In-Lbs	NEMA Motor Mount	Style Number	Catalog Number	List Price	Mult. Sym.	Ap'x Shpg. Wgt.		
		0.25	0.33	0.5	0.75	1	1.5	2	3	5									7.5	
350	5:1					160	240	320				2.00	320	56C	SSF-918-05-B5-G	SSGF0518AG	1,710	GB	30	
						160	240	320				2.00	320	140TC	SSF-918-05-B7-G	SSGF0518BG	1,710	GB	30	
						246	327	491				3.14	514	140TC	SSF-921-05-B7-G	SSGF0521BG	2,001	GB	35	
								339	508	847			5.43	919	140TC	SSF-926-05-B7-G	SSGF0526BG	2,813	GB	65
175	10:1			214	285	428						1.50	428	56C	SSF-918-10-B5-G	SSGF1018AG	1,710	GB	30	
				214	285	428						1.50	428	140TC	SSF-918-10-B7-G	SSGF1018BG	1,710	GB	30	
						312	468	624					2.02	630	140TC	SSF-921-10-B7-G	SSGF1021BG	2,001	GB	35
								655	983				3.59	1177	140TC	SSF-926-10-B7-G	SSGF1026BG	2,813	GB	65
117	15:1		209	314	419							1.07	448	56C	SSF-918-15-B5-G	SSGF1518AG	1,710	GB	30	
			246	369	492							1.35	664	56C	SSF-921-15-B5-G	SSGF1521AG	2,001	GB	35	
						473	710	947				2.58	1225	140TC	SSF-926-15-B7-G	SSGF1526BG	2,813	GB	65	
88	20:1		165	251	376							0.92	461	56C	SSF-918-20-B5-G	SSGF2018AG	1,710	GB	30	
				323	484	645						1.06	684	56C	SSF-921-20-B5-G	SSGF2021AG	2,001	GB	35	
						609	913	1218				2.15	1308	140TC	SSF-926-20-B7-G	SSGF2026BG	2,813	GB	65	
70	25:1		183	277	416							0.80	444	56C	SSF-918-25-B5-G	SSGF2518AG	1,710	GB	30	
			250	379	569							0.89	675	56C	SSF-921-25-B5-G	SSGF2521AG	2,001	GB	35	
						567	756	1134				1.73	1307	140TC	SSF-926-25-B7-G	SSGF2526BG	2,813	GB	65	
58	30:1		216	327								0.72	470	56C	SSF-918-30-B5-G	SSGF3018AG	1,710	GB	30	
			275	416	624							0.83	691	56C	SSF-921-30-B5-G	SSGF3021AG	2,001	GB	35	
						641	854	1281				1.54	1313	140TC	SSF-926-30-B7-G	SSGF3026BG	2,813	GB	56	
44	40:1		180	238	360							0.64	461	56C	SSF-918-40-B5-G	SSGF4018AG	1,710	GB	30	
				340	515							0.66	680	56C	SSF-921-40-B5-G	SSGF4021AG	2,001	GB	35	
						524	786	1049				1.23	1296	140TC	SSF-926-40-B7-G	SSGF4026BG	2,813	GB	56	
35	50:1		222	294								0.49	436	56C	SSF-918-50-B5-G	SSGF5018AG	1,710	GB	30	
			280	370	561							0.58	651	56C	SSF-921-50-B5-G	SSGF5021AG	2,001	GB	35	
						621	932	1242				1.00	1242	56C	SSF-926-50-B5-G	SSGF5026AG	2,813	GB	60	
29	60:1		220	290								0.47	413	56C	SSF-918-60-B5-G	SSGF6018AG	1,710	GB	30	
			317	418	634							0.50	634	56C	SSF-921-60-B5-G	SSGF6021AG	2,001	GB	35	
						473	716	1074				0.82	1166	56C	SSF-926-60-B5-G	SSGF6026AG	2,813	GB	56	

NOTE: Service Class I Torque Ratings (1.0 Service Factor) Service Class II Torque Ratings (≥ 1.4 Service Factor) Service Class III Torque Ratings (≥ 2.0 Service Factor)

Refer to Brochure CA1600 for Dimensions and Engineering Information. See notes on inside back flap.

Vertical motor below gearhead not recommended.
Avoiding those positions where the high speed oil seal is immersed in oil, will provide greater security against high speed input seal wear.
Horizontal bases, SSB18H71, SSB21H71 and SSB26H71, are available, see page 319.

**Stainless Steel –
Right Angle – Quill
Type Hollow Shaft**

1.75 thru 2.62 CD

56C thru 140TC

Applications: Baldor's all stainless speed reducers are easy to clean and sanitize, minimizing bacterial contamination for food processing equipment. Stainless steel provides the high protection for pharmaceutical and chemical processing applications where harsh chemicals and cleaning solutions can be extremely corrosive to aluminum, cast iron and other materials.

Features: Housing and covers are cast stainless steel to endure hostile environments. 300 Series stainless output shafts and all stainless steel hardware for long rust resistant life. O-ring sealed housing and motor interface helps keeps contaminants out. Pre-filled with food grade (H1) Klubersynth UH1-6-460 synthetic oil. Sealed housing provides maintenance-free lubed for life operation. BISSC certified (Baking Industry Sanitation Standards Committee).



SSGHF2026AH Shown

Nominal Output RPM @ 1750 RPM In	Gear Ratio	Continuous Duty Output Torque (In-Lbs) Based on 1750 RPM Motor										Max Input Hp	Max Output Torque Rating In-Lbs	NEMA Motor Mount	Style Number	Catalog Number	List Price	Mult. Sym.	Ap'x Shpg. Wgt.
		0.25	0.33	0.5	0.75	1	1.5	2	3	5	7.5								
350	5:1					160	240	320				2.00	320	56C	SSHF-918-05-B5-H	SSGHF0518AH	1,805	GB	30
175	10:1			214	285	428						1.50	428	56C	SSHF-918-10-B5-H	SSGHF1018AH	1,805	GB	30
					312	468	624					2.20	630	56C	SSHF-921-10-B5-H	SSGHF1021AH	2,091	GB	38
								990	1649			6.36	2106	180TC	SSHF-932-10-B9-H	SSGHF1032CH	4,633	GB	100
117	15:1		209	314	419							1.07	448	56C	SSHF-918-15-B5-H	SSGHF1518AH	1,805	GB	30
			246	369	492							1.35	664	56C	SSHF-921-15-B5-H	SSGHF1521AH	2,091	GB	38
								959	1438			4.66	2241	180TC	SSHF-932-15-B9-H	SSGHF1532CH	4,633	GB	100
88	20:1		165	251	376							0.92	461	56C	SSHF-918-20-B5-H	SSGHF2018AH	1,805	GB	30
				323	484	645						1.06	684	56C	SSHF-921-20-B5-H	SSGHF2021AH	2,091	GB	38
						609	913	1218				2.15	1309	56C	SSHF-926-20-B5-H	SSGHF2026AH	3,009	GB	60
							924	1232	1848			3.85	2383	180TC	SSHF-932-20-B9-H	SSGHF2032CH	4,633	GB	100
58	30:1		216	327								0.72	470	56C	SSHF-918-30-B5-H	SSGHF3018AH	1,805	GB	30
			275	416	624							0.83	691	56C	SSHF-921-30-B5-H	SSGHF3021AH	2,091	GB	38
					641	854	1281					1.54	1313	56C	SSHF-926-30-B5-H	SSGHF3026AH	3,009	GB	60
						881	1322	1763				2.81	2482	140TC	SSHF-932-39-B7-H	SSGHF3032BH	4,633	GB	100
44	40:1	180	238	360							0.64	461	56C	SSHF-918-40-B5-H	SSGHF4018AH	1,805	GB	30	
			340	515								0.66	680	56C	SSHF-921-40-B5-H	SSGHF4021AH	2,091	GB	38
				524	786	1049						1.23	1296	56C	SSHF-926-40-B5-H	SSGHF4026AH	3,009	GB	60
				524	786	1049						1.23	1296	140TC	SSHF-926-40-B7-H	SSGHF4026BH	3,009	GB	60
						1180	1620	2160				2.20	2374	140TC	SSHF-932-40-B7-H	SSGHF4032BH	4,633	GB	100
35	50:1	222	294								0.49	436	56C	SSHF-918-50-B5-H	SSGHF5018AH	1,805	GB	30	
		280	370	561							0.58	651	56C	SSHF-921-50-B5-H	SSGHF5021AH	2,091	GB	38	
				621	932	1242						1.00	1242	56C	SSHF-926-50-B5-H	SSGHF5026AH	3,009	GB	53
					958	1278	1917					1.83	2366	140TC	SSHF-932-50-B7-H	SSGHF5032BH	4,633	GB	100
29	60:1	220	290								0.47	413	56C	SSHF-918-60-B5-H	SSGHF6018AH	1,805	GB	30	
		317	418	634							0.50	634	56C	SSHF-921-60-B5-H	SSGHF6021AH	2,091	GB	38	
			473	716	1074							0.82	1166	56C	SSHF-926-60-B5-H	SSGHF6026AH	3,009	GB	60
					1100	1467	2200					1.54	2255	140TC	SSHF-932-60-B7-H	SSGHF6032BH	4,633	GB	100

NOTE: Service Class I Torque Ratings (1.0 Service Factor)
 Service Class II Torque Ratings (≥ 1.4 Service Factor)
 Service Class III Torque Ratings (≥ 2.0 Service Factor)

Refer to Brochure CA1600 for Dimensions and Engineering Information.
See notes on inside back flap.

Vertical motor below gearhead not recommended.
 Avoiding those positions where the high speed oil seal is immersed in oil, will provide greater security against high speed input seal wear.
 Horizontal bases, SSB18H71, SSB21H71 and SSB26H71, are available, see page 319.

Washdown – Right Angle – Quill Type Solid Shaft



WDGF1018AG Shown

1.33 thru 3.25 CD

56C thru 140TC

Applications: Food processing and other applications regularly exposed to high pressure washdown.

Features: Epoxy coated, heavy-duty cast iron housing. Stainless steel output shaft and hardware. Sealed housing, provides maintenance-free, lubed for life operation. Pre-filled with food grade (H1) Klubersynth synthetic oil. Industry standard mounting dimensionally interchangeable with many other worm gear reducers. BISSC certified (Baking Industry Sanitation Standards Committee).

Nominal Output RPM @ 1750 RPM In	Gear Ratio	Continuous Duty Output Torque (In-Lbs) Based on 1750 RPM Motor									Max Input Hp	Max Output Torque Rating In-Lbs	NEMA Motor Mount	Style Number	Catalog Number	List Price	Mult. Sym.	Ap'x Shpg. Wgt.
		0.25	0.33	0.5	0.75	1	1.5	2	3	5								
350	5:1					160	240	320			2.00	320	56C	WDF-918-05-B5-G	WDGF0518AG	675	GB	30
175	10:1	82	125	187							0.90	225	56C	WDF-913-10-B5-G	WDGF1013AG	628	GB	20
			141	211	282						1.03	290	56C	WDF-915-10-B5-G	WDGF1015AG	664	GB	25
			141	211	282						1.03	290	140TC	WDF-915-10-B7-G	WDGF1015BG	664	GB	25
				214	285	428					1.50	428	56C	WDF-918-10-B5-G	WDGF1018AG	675	GB	30
					312	468	624				2.20	630	56C	WDF-921-10-B5-G	WDGF1021AG	832	GB	35
117	15:1			317	475	634				2.73	893	140TC	WDF-924-10-B7-G	WDGF1024BG	974	GB	40	
		89	118	179							0.66	225	56C	WDF-913-15-B5-G	WDGF1513AG	628	GB	20
			127	193	289						0.81	312	56C	WDF-915-15-B5-G	WDGF1515AG	664	GB	25
				209	314	419					1.07	448	56C	WDF-918-15-B5-G	WDGF1518AG	675	GB	30
				246	369	492					1.35	664	56C	WDF-921-15-B5-G	WDGF1521AG	832	GB	35
88	20:1			470	705	939				2.11	992	56C	WDF-924-15-B5-G	WDGF1524AG	974	GB	40	
		113	149	226							0.53	239	56C	WDF-913-20-B5-G	WDGF2013AG	628	GB	20
			128	169	256						0.62	317	56C	WDF-915-20-B5-G	WDGF2015AG	664	GB	25
			165	251	376						0.92	461	56C	WDF-918-20-B5-G	WDGF2018AG	675	GB	30
					609	913	1218				2.15	1309	140TC	WDF-926-20-B7-G	WDGF2026BG	1,113	GB	52
58	30:1		216	327							0.72	470	56C	WDF-918-30-B5-G	WDGF3018AG	675	GB	30
			275	416	624						0.83	691	56C	WDF-921-30-B5-G	WDGF3021AG	832	GB	35
				420	630	840					1.32	111	56C	WDF-924-30-B5-G	WDGF3024AG	974	GB	40
					641	854	1281				1.54	1313	56C	WDF-926-30-B5-G	WDGF3026AG	1,113	GB	55
					881	1322	1763				2.81	2462	140TC	WDF-932-30-B7-G	WDGF3032BG	1,633	GB	87
44	40:1	208	275								0.44	317	56C	WDF-915-40-B5-G	WDGF4015AG	664	GB	25
			180	238	360						0.64	461	56C	WDF-918-40-B5-G	WDGF4018AG	675	GB	30
				340	515						0.66	680	56C	WDF-921-40-B5-G	WDGF4021AG	832	GB	35
				521	781						0.99	1030	56C	WDF-924-40-B5-G	WDGF4024AG	974	GB	40
				524	786	1049					1.23	1296	56C	WDF-926-40-B5-G	WDGF4026AG	1,113	GB	55
35	50:1			1081	1622	2163				2.20	2374	140TC	WDF-932-40-B7-G	WDGF4032BG	1,633	GB	87	
		177	234								0.33	234	56C	WDF-913-50-B5-G	WDGF5013AG	628	GB	20
			230	303							0.33	303	56C	WDF-915-50-B5-G	WDGF5015AG	664	GB	25
			280	370	561						0.58	651	56C	WDF-921-50-B5-G	WDGF5021AG	832	GB	35
				401	608	912					0.83	1014	56C	WDF-924-50-B5-G	WDGF5024AG	974	GB	40
29	60:1			621	932	1242				1.00	1242	56C	WDF-926-50-B5-G	WDGF5026AG	1,113	GB	55	
				958	1278	1917				1.83	2366	140TC	WDF-932-50-B7-G	WDGF5032BG	1,633	GB	92	
		218	288								0.33	288	56C	WDF-915-60-B5-G	WDGF6015AG	664	GB	25
			220	290							0.47	413	56C	WDF-918-60-B5-G	WDGF6018AG	675	GB	30
			317	418	634						0.50	634	56C	WDF-921-60-B5-G	WDGF6021AG	832	GB	35
29	60:1		458	693						0.69	956	56C	WDF-924-60-B5-G	WDGF6024AG	974	GB	40	
			473	716	1074					0.82	1166	56C	WDF-926-60-B5-G	WDGF6026AG	1,113	GB	55	
				1100	1467	2200					1.54	2255	56C	WDF-932-60-B5-G	WDGF6032AG	1,633	GB	92

NOTE: Service Class I Torque Ratings (1.0 Service Factor) See notes on inside back flap.
 Service Class II Torque Ratings (≥ 1.4 Service Factor)
 Service Class III Torque Ratings (≥ 2.0 Service Factor)

900 Series – Right Angle – Coupling Type – Solid Shaft

1.33 thru 3.75 CD

56C thru 180TC

Applications: Ideal for conveyors, material handling, textile machines, packaging machinery, etc. (slow speed and high torque).

Features: Heavy duty cast iron housings, chill cast bronze gears, precision ground hardened worm, ball bearings on input shaft, tapered roller bearings on output shaft. Industry-standard mounting dimensions. Pre-filled with food grade (H1) Klubersynth UH1-6-460 synthetic oil, sealed housing provides maintenance-free lubed for life operation. Motor coupling included.



GLF1018AG Shown

Nominal Output RPM @ 1750 RPM In	Gear Ratio	Continuous Duty Output Torque (In-Lbs) Based on 1750 RPM Motor										Max Input Hp	Max Output Torque Rating In-Lbs	NEMA Motor Mount	Style Number	Catalog Number	List Price	Mult. Sym.	Ap'x Shpg. Wgt.	
		0.25	0.33	0.5	0.75	1	1.5	2	3	5	7.5									
350	5:1			115	154	231						1.50	231	56C	LF-915-05-B5-G	GLF0515AG	561	GB	30	
223	7.5:1				237	356	474					2.70	640	56C	LF-921-7.5-B5-G	GLF0821AG	710	GB	38	
					237	356	474					2.70	640	56C	LF-921-7.5-B5-J	GLF0821AJ	710	GB	38	
					237	356	474						2.70	640	140TC	LF-921-7.5-B7-G	GLF0821BG	710	GB	38
								501	752				4.30	1079	140TC	LF-926-7.5-B7-G	GLF0826BG	974	GB	60
								501	752				4.30	1079	180TC	LF-926-7.5-B9-G	GLF0826CG	974	GB	60
175	10:1			214	285	428						1.50	428	56C	LF-918-10-B5-G	GLF1018AG	575	GB	32	
					312	468	624					2.02	630	56C	LF-921-10-B5-G	GLF1021AG	710	GB	38	
					312	468	624					2.02	630	140TC	LF-921-10-B7-G	GLF1021BG	710	GB	38	
					312	468	624					2.02	630	140TC	LF-921-10-B7-J	GLF1021BJ	710	GB	38	
					317	475	634					2.73	893	140TC	LF-924-10-B7-G	GLF1024BG	834	GB	45	
								655	983				3.59	1177	140TC	LF-926-10-B7-G	GLF1026BG	974	GB	60
								655	983				3.59	1177	180TC	LF-926-10-B9-G	GLF1026CG	974	GB	60
117	15:1		89	118	179							0.66	2228	56C	LF-913-15-B5-G	GLF1513AG	516	GB	20	
				246	369	492						1.35	664	56C	LF-921-15-B5-G	GLF1521AG	710	GB	38	
				246	369	492						1.35	664	56C	LF-921-15-B5-J	GLF1521AJ	710	GB	38	
					473	710	947					2.58	1225	140TC	LF-926-15-B7-G	GLF1526BG	974	GB	60	
					473	710	947					2.58	1225	140TC	LF-926-15-B7-J	GLF1526BJ	974	GB	60	
								959	1438				4.66	2241	180TC	LF-932-15-B9-G	GLF1532CG	1,419	GB	100
								959	1438				4.66	2241	180TC	LF-932-15-B9-J	GLF1532CJ	1,419	GB	105
88	20:1		113	149	226							0.53	239	56C	LF-913-20-B5-G	GLF2013AG	516	GB	20	
				165	251	376						0.92	464	56C	LF-918-20-B5-G	GLF2018AG	575	GB	32	
				323	484	645						1.06	684	56C	LF-921-20-B5-G	GLF2021AG	710	GB	38	

NOTE: Service Class I Torque Ratings (1.0 Service Factor)
 Service Class II Torque Ratings (≥ 1.4 Service Factor)
 Service Class III Torque Ratings (≥ 2.0 Service Factor)

Optional Shaft Positions, Base Installation and Motor Mounting available through Mod Express. Refer to a Baldor District Office for pricing and delivery. See notes on inside back flap.

Vertical motor below gearhead not recommended.

Avoiding those positions where the high speed oil seal is immersed in oil, will provide greater security against high speed input seal wear.

Assembly Types

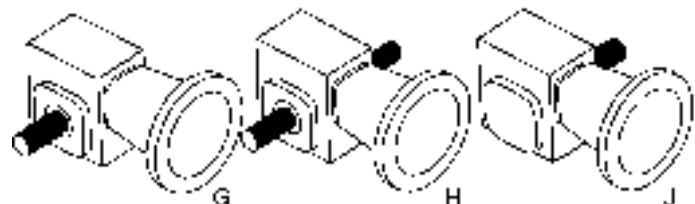

900 Series – Right Angle – Coupling Type – Solid Shaft continued...

Nominal Output RPM @ 1750 RPM In	Gear Ratio	Continuous Duty Output Torque (In-Lbs) Based on 1750 RPM Motor										Max Input Hp	Max Output Torque Rating In-Lbs	NEMA Motor Mount	Style Number	Catalog Number	List Price	Mult. Sym.	Ap'x Shpg. Wgt.
		0.25	0.33	0.5	0.75	1	1.5	2	3	5	7.5								
88	20:1			323	484	645						1.06	684	56C	LF-921-20-B5-J	GLF2021AJ	710	GB	38
						609	913	1218				2.15	1308	140TC	LF-926-20-B7-G	GLF2026BG	974	GB	60
						609	913	1218				2.15	1308	140TC	LF-926-20-B7-J	GLF2026BJ	974	GB	60
							924	1232	1848			3.85	2383	180TC	LF-932-20-B9-G	GLF2032CG	1,419	GB	100
70	25:1	156	296	312								0.51	318	56C	LF-915-25-B5-G	GLF2515AG	561	GB	30
			183	277	416							0.80	444	56C	LF-918-25-B5-B	GLF2518AG	575	GB	32
			250	379	549							0.89	675	56C	LF-921-25-B5-G	GLF2521AG	710	GB	38
			250	379	569							0.89	675	56C	LF-921-25-B5-J	GLF2521AJ	710	GB	38
					567	756	1134					1.73	1307	56C	LF-926-25-B5-G	GLF2526AG	974	GB	60
					567	756	1134					1.73	1307	140TC	LF-926-25-B7-G	GLF2526BG	974	GB	60
					567	756	1134					1.73	1307	140TC	LF-926-25-B7-J	GLF2526BJ	974	GB	60
							1134	1513	2269			3.13	2355	140TC	LF-932-25-B7-G	GLF2532BG	1,419	GB	100
							1134	1513	2269			3.13	2355	180TC	LF-932-25-B9-G	GLF2532CG	1,419	GB	100
							1134	1513	2269			3.13	2355	180TC	LF-932-25-B9-J	GLF2532CJ	1,419	GB	100
58	30:1	148	195									0.42	248	56C	LF-913-30-B5-G	GLF3013AG	516	GB	20
		159	210	318								0.50	318	56C	LF-915-30-B5-G	GLF3015AG	561	GB	30
			216	327								0.72	470	56C	LF-918-30-B5-G	GLF3018AG	575	GB	32
			216	327								0.72	470	56C	LF-918-30-B5-J	GLF3018AJ	575	GB	32
			275	416	624							0.83	691	56C	LF-921-30-B5-G	GLF3021AG	710	GB	38
				420	630	840						1.32	1111	56C	LF-924-30-B5-G	GLF3024AG	834	GB	45
					641	854	1281					1.54	1313	140TC	LF-926-30-B7-G	GLF3026BG	974	GB	60
					641	854	1281					1.54	1313	140TC	LF-926-30-B7-J	GLF3026BJ	974	GB	60
							881	1322	1763			2.81	2482	180TC	LF-932-30-B9-G	GLF3032CG	1,419	GB	100
								1626	2438			3.97	3226	180TC	LF-938-30-B9-G	GLF3038CG	1,733	GB	130
44	40:1	180	238	360								0.64	461	56C	LF-918-40-B5-G	GLF4018AG	575	GB	32
				521	781							0.99	1030	56C	LF-924-40-B5-G	GLF4024AG	834	GB	45
				524	786	1049						1.23	1296	56C	LF-926-40-B5-G	GLF4026AG	974	GB	60
						1180	1620	2160				2.20	2374	140TC	LF-932-40-B7-G	GLF4032BG	1,419	GB	100
						1596	2129	3192			3.00	3192	180TC	LF-938-40-B9-G	GLF4038CG	1,733	GB	130	
35	50:1	280	370	561								0.58	651	56C	LF-921-50-B5-G	GLF5021AG	710	GB	38
				621	932	1242						1.00	1242	56C	LF-926-50-B5-G	GLF5026AG	974	GB	60
29	60:1	218	288									0.33	288	56C	LF-915-60-B5-G	GLF6015AG	561	GB	30
		220	290									0.47	413	56C	LF-918-60-B5-G	GLF6018AG	575	GB	32
		317	418	634								0.50	634	56C	LF-921-60-B5-G	GLF6021AG	710	GB	38
			473	716	1074							0.82	1166	56C	LF-926-60-B5-G	GLF6026AG	974	GB	60
					1100	1467	2200					1.54	2255	56C	LF-932-60-B5-G	GLF6032AG	1,419	GB	100
					1100	1467	2200					1.54	2255	140TC	LF-932-60-B7-G	GLF6032BG	1,419	GB	100

NOTE: Service Class I Torque Ratings (1.0 Service Factor)
 Service Class II Torque Ratings (≥ 1.4 Service Factor)
 Service Class III Torque Ratings (≥ 2.0 Service Factor)

Suffix G = Left hand output facing input
 J = Right hand output facing input
 H = Double Output Shaft

Vertical motor below gearhead not recommended.

Avoiding those positions where the high speed oil seal is immersed in oil, will provide greater security against high speed input seal wear.

Assembly Types

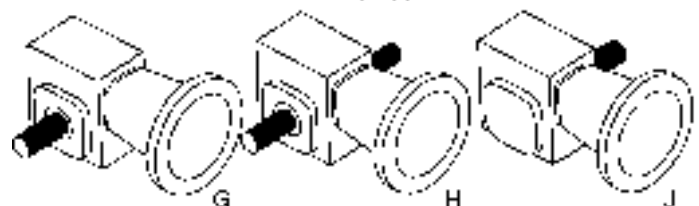

Gearmotors and Gear Products

Motor Accessories

PT Components

Grinders

Baldor Mod Express

ABB Mod Express

Product Index

900 Series - Right Angle - Solid Shaft

1.33 thru 2.62 CD



GS3018G Shown

Applications: Ideal for conveyors, material handling, textile machines, packaging machinery and more. Suitable for direct coupling or belted input (slow speed and high torque).

Features: Heavy duty cast iron housings, chill cast bronze gears, precision ground hardened worm, ball bearings on input shaft, tapered roller bearings on output shaft. Industry-standard mounting dimensions. Pre-filled with food grade (H1) Klubersynth UH1-6-460 synthetic oil, sealed housing provides maintenance-free lubed for life operation.

Nominal Output RPM @ 1750 RPM In	Gear Ratio	Continuous Duty Output Torque (In-Lbs) Based on 1750 RPM Motor										Max Input Hp	Max Output Torque Rating In-Lbs	Style Number	Catalog Number	List Price	Mult. Sym.	Ap'x Shpg. Wgt.
		0.25	0.33	0.5	0.75	1	1.5	2	3	5	7.5							
175	10:1				214	285	428					1.50	428	S-918-10-G	GS1018G	482	GB	25
						312	468	624				2.02	630	S-921-10-G	GS1021G	568	GB	28
								492	655			3.59	1177	S-926-10-G	GS1026G	798	GB	50
117	15:1	96	127	193							0.66	225	S-915-15-G	GS1515G	476	GB	21	
				209	314	419					1.07	448	S-918-15-G	GS1518G	482	GB	25	
				246	369	492					1.35	664	S-921-15-G	GS1521G	568	GB	28	
88	20:1		165	251	376						0.92	461	S-918-20-G	GS2018G	482	GB	25	
				323	484	645					1.06	684	S-921-20-G	GS2021G	568	GB	28	
					451	602	902				1.72	1038	S-924-20-G	GS2024G	708	GB	38	
						609	913	1218			2.15	1308	S-926-20-G	GS2026G	798	GB	50	
		156	206	312							0.51	318	S-915-25-G	GS2515G	476	GB	21	
58	30:1	148	195							0.42	248	S-913-30-G	GS3013G	461	GB	18		
			216	327						0.72	470	S-918-30-G	GS3018G	482	GB	25		
			275	416	624					0.83	691	S-921-30-G	GS3021G	568	GB	28		
					641	854	1281			1.54	1313	S-926-30-G	GS3026G	798	GB	50		
44	40:1	208	275							0.38	317	S-915-40-G	GS4015G	476	GB	21		
		180	238	360						0.64	461	S-918-40-G	GS4018G	482	GB	25		
			340	515						0.66	680	S-921-40-G	GS4021G	568	GB	28		
					524	786	1049			1.23	1296	S-926-40-G	GS4026G	798	GB	50		
35	50:1	222	294							0.49	436	S-918-50-G	GS5018G	482	GB	25		
		280	370	561						0.59	651	S-921-50-G	GS5021G	568	GB	28		
					621	932	1242			1.00	1242	S-926-50-G	GS5026G	798	GB	50		
29	60:1	179								0.28	201	S-913-60-G	GS6013G	461	GB	15		
		218	288							0.33	288	S-915-60-G	GS6015G	476	GB	21		
		220	290							0.47	413	S-918-60-G	GS6018G	482	GB	25		
		317	418	634						0.50	634	S-921-60-G	GS6021G	568	GB	31		
			458	693						0.69	958	S-924-60-G	GS6024G	708	GB	38		
			473	716	1074					0.82	1166	S-926-60-G	GS6026G	798	GB	50		

NOTE: Service Class I Torque Ratings (1.0 Service Factor)
 Service Class II Torque Ratings (≥ 1.4 Service Factor)
 Service Class III Torque Ratings (≥ 2.0 Service Factor)

Optional Shaft Positions and Base Installation available through Mod Express.
 Refer to a Baldor District Office for pricing and delivery.
 See notes on inside back flap.

Vertical motor below gearhead not recommended.
 Avoiding those positions where the high speed oil seal is immersed in oil, will provide greater security against high speed input seal wear.

**1/4 Horsepower
Stock Gear-Motors**



Baldor has pre-selected and assembled our stock 900 Series* speed reducers to our most stock popular single-phase, three-phase and DC Industrial motors. These pre-assembled *Gear-Motors* offer a variety of output torques and output speeds to fit most industrial applications. To order, select the desired output speed and torque, then choose the corresponding Baldor catalog number. Your *Gear-Motor* will ship in one package, pre-assembled from the factory within 48 hours.

RPM	Service Factor	Output Torque In. Lbs.	Max. Overhung Load Rating	Ratio	NEMA Input	Catalog Number	List Price	Mult. Sym.	Ap'x. Shpg. Wgt.
TEFC, 1 Phase 115/230 Volt									
350	4.40	37	240	5:1	56C	GF0513AGA25	814	GB	40
175	3.60	62	240	10:1	56C	GF1013AGA25	814	GB	40
117	2.60	85	240	15:1	56C	GF1513AGA25	814	GB	40
88	2.10	112	240	20:1	56C	GF2013AGA25	814	GB	40
70	2.00	119	240	25:1	56C	GF2513AGA25	814	GB	40
58	1.70	147	240	30:1	56C	GF3013AGA25	814	GB	40
44	1.30	174	240	40:1	56C	GF4013AGA25	814	GB	40
35	1.30	229	300	50:1	56C	GF5015AGA25	849	GB	45
29	1.30	218	300	60:1	56C	GF6015AGA25	849	GB	45
TEFC, 3 Phase 230/460 Volt									
350	4.40	37	240	5:1	56C	GF0513AGB25	809	GB	39
175	3.60	62	240	10:1	56C	GF1013AGB25	809	GB	39
117	2.60	85	240	15:1	56C	GF1513AGB25	809	GB	39
88	2.10	112	240	20:1	56C	GF2013AGB25	809	GB	39
70	2.00	119	240	25:1	56C	GF2513AGB25	809	GB	39
58	1.70	147	240	30:1	56C	GF3013AGB25	809	GB	39
44	1.30	174	240	40:1	56C	GF4013AGB25	809	GB	39
35	1.30	229	300	50:1	56C	GF5015AGB25	843	GB	44
29	1.30	218	300	60:1	56C	GF6015AGB25	843	GB	44
TENV, DC SCR, 90 Volts									
350	4.40	37	240	5:1	56C	GF0513AGC25	1,147	GB	44
175	3.60	62	240	10:1	56C	GF1013AGC25	1,147	GB	44
117	2.60	85	240	15:1	56C	GF1513AGC25	1,147	GB	44
88	2.10	112	240	20:1	56C	GF2013AGC25	1,147	GB	44
70	2.00	119	240	25:1	56C	GF2513AGC25	1,147	GB	44
58	1.70	147	240	30:1	56C	GF3013AGC25	1,147	GB	44
44	1.30	174	240	40:1	56C	GF4013AGC25	1,147	GB	44
35	1.30	229	300	50:1	56C	GF5015AGC25	1,182	GB	49
29	1.30	218	300	60:1	56C	GF6015AGC25	1,182	GB	49
TENV, DC SCR, 180 Volts									
350	4.40	37	240	5:1	56C	GF0513AGD25	1,147	GB	44
175	3.60	62	240	10:1	56C	GF1013AGD25	1,147	GB	44
117	2.60	85	240	15:1	56C	GF1513AGD25	1,147	GB	44
88	2.10	112	240	20:1	56C	GF2013AGD25	1,147	GB	44
70	2.00	119	240	25:1	56C	GF2513AGD25	1,147	GB	44
58	1.70	147	240	30:1	56C	GF3013AGD25	1,147	GB	44
44	1.30	174	240	40:1	56C	GF4013AGD25	1,147	GB	44
35	1.30	229	300	50:1	56C	GF5015AGD25	1,182	GB	49
29	1.30	218	300	60:1	56C	GF6015AGD25	1,182	GB	49

NOTE: *See page 297 for 900 Series features.

1/3 Horsepower Stock Gear-Motors



Baldor has pre-selected and assembled our stock 900 Series* speed reducers to our most stock popular single-phase, three-phase and DC Industrial motors. These pre-assembled *Gear-Motors* offer a variety of output torques and output speeds to fit most industrial applications. To order, select the desired output speed and torque, then choose the corresponding Baldor catalog number. Your *Gear-Motor* will ship in one package, pre-assembled from the factory within 48 hours.

RPM	Service Factor	Output Torque In. Lbs.	Max. Overhung Load Rating	Ratio	NEMA Input	Catalog Number	List Price	Mult. Sym.	Ap'x. Shpg. Wgt.
TEFC, 1 Phase 115/230 Volt									
350	3.30	49	240	5:1	56C	GF0513AGA33	849	GB	42
175	2.70	82	240	10:1	56C	GF1013AGA33	849	GB	42
117	2.00	113	240	15:1	56C	GF1513AGA33	849	GB	42
88	1.60	148	240	20:1	56C	GF2013AGA33	849	GB	42
70	1.50	157	240	25:1	56C	GF2513AGA33	849	GB	42
58	1.50	209	300	30:1	56C	GF3015AGA33	883	GB	47
44	1.90	237	600	40:1	56C	GF4018AGA33	897	GB	52
35	1.50	293	600	50:1	56C	GF5018AGA33	897	GB	52
29	1.60	289	600	60:1	56C	GF6018AGA33	897	GB	52
TEFC, 3 Phase, 230/460 Volt									
350	3.30	49	240	5:1	56C	GF0513AGB33	834	GB	42
175	2.70	82	240	10:1	56C	GF1013AGB33	834	GB	42
117	2.00	113	240	15:1	56C	GF1513AGB33	834	GB	42
88	1.60	148	240	20:1	56C	GF2013AGB33	834	GB	42
70	1.50	157	240	25:1	56C	GF2513AGB33	834	GB	42
58	1.50	209	300	30:1	56C	GF3015AGB33	869	GB	47
44	1.90	237	600	40:1	56C	GF4018AGB33	882	GB	52
35	1.50	293	600	50:1	56C	GF5018AGB33	882	GB	52
29	1.60	289	600	60:1	56C	GF6018AGB33	882	GB	52
TENV, DC SCR, 90 Volt									
350	3.30	49	240	5:1	56C	GF0513AGC33	1,183	GB	47
175	2.70	82	240	10:1	56C	GF1013AGC33	1,183	GB	47
117	2.00	113	240	15:1	56C	GF1513AGC33	1,183	GB	47
88	1.60	148	240	20:1	56C	GF2013AGC33	1,183	GB	47
70	1.50	157	240	25:1	56C	GF2513AGC33	1,183	GB	47
58	1.50	209	300	30:1	56C	GF3015AGC33	1,218	GB	52
44	1.90	237	600	40:1	56C	GF4018AGC33	1,231	GB	57
35	1.50	293	600	50:1	56C	GF5018AGC33	1,231	GB	57
29	1.60	289	600	60:1	56C	GF6018AGC33	1,231	GB	57
TENV, DC SCR, 180 Volt									
350	3.30	49	240	5:1	56C	GF0513AGD33	1,183	GB	47
175	2.70	82	240	10:1	56C	GF1013AGD33	1,183	GB	47
117	2.00	113	240	15:1	56C	GF1513AGD33	1,183	GB	47
88	1.60	148	240	20:1	56C	GF2013AGD33	1,183	GB	47
70	1.50	157	240	25:1	56C	GF2513AGD33	1,183	GB	47
58	1.50	209	300	30:1	56C	GF3015AGD33	1,218	GB	52
44	1.90	237	600	40:1	56C	GF4018AGD33	1,231	GB	57
35	1.50	293	600	50:1	56C	GF5018AGD33	1,231	GB	57
29	1.60	289	600	60:1	56C	GF6018AGD33	1,231	GB	57

NOTE: *See page 297 for 900 Series features.

**1/2 Horsepower
Stock Gear-Motors**



Baldor has pre-selected and assembled our stock 900 Series* speed reducers to our most stock popular single-phase, three-phase and DC Industrial motors. These pre-assembled *Gear-Motors* offer a variety of output torques and output speeds to fit most industrial applications. To order, select the desired output speed and torque, then choose the corresponding Baldor catalog number. Your *Gear-Motor* will ship in one package, pre-assembled from the factory within 48 hours.

RPM	Service Factor	Output Torque In. Lbs.	Max. Overhung Load Rating	Ratio	NEMA Input	Catalog Number	List Price	Mult. Sym.	Ap'x. Shpg. Wgt.
TEFC, 1 Phase 115/230 Volt									
350	2.20	74	240	5:1	56C	GF0513AGA50	907	GB	47
175	1.80	125	240	10:1	56C	GF1013AGA50	907	GB	47
117	1.60	192	300	15:1	56C	GF1515AGA50	941	GB	52
88	1.80	250	600	20:1	56C	GF2018AGA50	955	GB	57
70	1.60	278	600	25:1	56C	GF2518AGA50	955	GB	57
58	1.40	326	600	30:1	56C	GF3018AGA50	955	GB	57
44	1.30	515	750	40:1	56C	GF4021AGA50	1,094	GB	62
35	1.66	610	1000	50:1	56C	GF5024AGA50	1,218	GB	67
29	1.40	694	1000	60:1	56C	GF6024AGA50	1,218	GB	67
TEFC, 3 Phase, 230/460 Volt									
350	2.20	74	240	5:1	56C	GF0513AGB50	882	GB	43
175	1.80	125	240	10:1	56C	GF1013AGB50	882	GB	43
117	1.60	192	300	15:1	56C	GF1515AGB50	917	GB	48
88	1.80	250	600	20:1	56C	GF2018AGB50	931	GB	53
70	1.60	278	600	25:1	56C	GF2518AGB50	931	GB	53
58	1.40	326	600	30:1	56C	GF3018AGB50	931	GB	53
44	1.30	515	750	40:1	56C	GF4021AGB50	1,069	GB	58
35	1.66	610	1000	50:1	56C	GF5024AGB50	1,193	GB	63
29	1.40	694	1000	60:1	56C	GF6024AGB50	1,193	GB	63
ENV, DC SCR, 90 Volt									
350	2.20	74	240	5:1	56C	GF0513AGC50	1,264	GB	52
175	1.80	125	240	10:1	56C	GF1013AGC50	1,264	GB	52
117	1.60	192	300	15:1	56C	GF1515AGC50	1,299	GB	57
88	1.80	250	600	20:1	56C	GF2018AGC50	1,312	GB	62
70	1.60	278	600	25:1	56C	GF2518AGC50	1,312	GB	62
58	1.40	326	600	30:1	56C	GF3018AGC50	1,312	GB	62
44	1.30	515	750	40:1	56C	GF4021AGC50	1,451	GB	67
35	1.66	610	1000	50:1	56C	GF5024AGC50	1,575	GB	72
29	1.40	694	1000	60:1	56C	GF6024AGC50	1,575	GB	72
TENV, DC SCR, 180 Volt									
350	2.20	74	240	5:1	56C	GF0513AGD50	1,264	GB	51
175	1.80	125	240	10:1	56C	GF1013AGD50	1,264	GB	51
117	1.60	192	300	15:1	56C	GF1515AGD50	1,299	GB	56
88	1.80	250	600	20:1	56C	GF2018AGD50	1,312	GB	61
70	1.60	278	600	25:1	56C	GF2518AGD50	1,312	GB	61
58	1.40	326	600	30:1	56C	GF3018AGD50	1,312	GB	61
44	1.30	515	750	40:1	56C	GF4021AGD50	1,451	GB	66
35	1.66	610	1000	50:1	56C	GF5024AGD50	1,575	GB	71
29	1.40	694	1000	60:1	56C	GF6024AGD50	1,575	GB	71

NOTE: *See page 297 for 900 Series features.

Gearmotors and Gear Products

Motor Accessories

PT Components

Grinders

Baldor Mod Express

ABB Mod Express

Product Index

3/4 Horsepower Stock Gear-Motors



Baldor has pre-selected and assembled our stock 900 Series* speed reducers to our most stock popular single-phase, three-phase and DC Industrial motors. These pre-assembled *Gear-Motors* offer a variety of output torques and output speeds to fit most industrial applications. To order, select the desired output speed and torque, then choose the corresponding Baldor catalog number. Your *Gear-Motor* will ship in one package, pre-assembled from the factory within 48 hours.

RPM	Service Factor	Output Torque In. Lbs.	Max. Overhung Load Rating	Ratio	NEMA Input	Catalog Number	List Price	Mult. Sym.	Ap'x. Shpg. Wgt.
TEFC, 1 Phase 115/230 Volt									
350	1.50	111	240	5:1	56C	GF0513AGA75	965	GB	54
175	1.20	187	240	10:1	56C	GF1013AGA75	965	GB	54
117	1.40	360	600	15:1	56C	GF1518AGA75	1,014	GB	64
88	1.20	375	600	20:1	56C	GF2018AGA75	1,014	GB	64
70	1.20	568	750	25:1	56C	GF2521AGA75	1,152	GB	69
58	1.10	624	750	30:1	56C	GF3021AGA75	1,152	GB	69
44	1.30	780	1000	40:1	56C	GF4024AGA75	1,276	GB	74
35	1.10	916	1000	50:1	56C	GF5024AGA75	1,276	GB	74
29	1.10	1066	1000	60:1	56C	GF6026AGA75	1,276	GB	74
TEFC, 3 Phase, 230/460 Volt									
350	1.50	111	240	5:1	56C	GF0513AGB75	907	GB	45
175	1.20	187	240	10:1	56C	GF1013AGB75	907	GB	45
117	1.40	360	600	15:1	56C	GF1518AGB75	955	GB	55
88	1.20	375	600	20:1	56C	GF2018AGB75	955	GB	55
70	1.20	568	750	25:1	56C	GF2521AGB75	1,094	GB	60
58	1.10	624	750	30:1	56C	GF3021AGB75	1,094	GB	60
44	1.30	780	1000	40:1	56C	GF4024AGB75	1,218	GB	65
35	1.10	916	1000	50:1	56C	GF5024AGB75	1,218	GB	65
29	1.10	1066	1000	60:1	56C	GF6026AGB75	1,218	GB	65
TENV, DC SCR, 90 Volt									
350	1.50	111	240	5:1	56C	GF0513AGC75	1,427	GB	59
175	1.20	187	240	10:1	56C	GF1013AGC75	1,427	GB	59
117	1.40	360	600	15:1	56C	GF1518AGC75	1,475	GB	69
88	1.20	375	600	20:1	56C	GF2018AGC75	1,475	GB	69
70	1.20	568	750	25:1	56C	GF2521AGC75	1,614	GB	74
58	1.10	624	750	30:1	56C	GF3021AGC75	1,614	GB	74
44	1.30	780	1000	40:1	56C	GF4024AGC75	1,738	GB	79
35	1.10	916	1000	50:1	56C	GF5024AGC75	1,738	GB	79
29	1.10	1066	1000	60:1	56C	GF6026AGC75	1,738	GB	79
TENV, DC SCR, 180 Volt									
350	1.50	111	240	5:1	56C	GF0513AGD75	1,427	GB	59
175	1.20	187	240	10:1	56C	GF1013AGD75	1,427	GB	59
117	1.40	360	600	15:1	56C	GF1518AGD75	1,475	GB	69
88	1.20	375	600	20:1	56C	GF2018AGD75	1,475	GB	69
70	1.20	568	750	25:1	56C	GF2521AGD75	1,614	GB	74
58	1.10	624	750	30:1	56C	GF3021AGD75	1,614	GB	74
44	1.30	780	1000	40:1	56C	GF4024AGD75	1,738	GB	79
35	1.10	916	1000	50:1	56C	GF5024AGD75	1,738	GB	79
29	1.10	1066	1000	60:1	56C	GF6026AGD75	1,738	GB	79

NOTE: *See page 297 for 900 Series features.

**1 Horsepower
Stock Gear-Motors**



Baldor has pre-selected and assembled our stock 900 Series* speed reducers to our most stock popular single-phase, three-phase and DC Industrial motors. These pre-assembled *Gear-Motors* offer a variety of output torques and output speeds to fit most industrial applications. To order, select the desired output speed and torque, then choose the corresponding Baldor catalog number. Your *Gear-Motor* will ship in one package, pre-assembled from the factory within 48 hours.

RPM	Service Factor	Output Torque In. Lbs.	Max. Overhung Load Rating	Ratio	NEMA Input	Catalog Number	List Price	Mult. Sym.	Ap'x. Shpg. Wgt.
TEFC, 1 Phase 115/230 Volt									
350	1.10	149	240	5:1	56C	GF0513AGA10	1,033	GB	58
175	1.50	285	600	10:1	56C	GF1018AGA10	1,081	GB	68
117	1.35	491	750	15:1	56C	GF1521AGA10	1,220	GB	73
88	1.70	603	1000	20:1	56C	GF2024AGA10	1,344	GB	78
70	1.40	730	1000	25:1	56C	GF2524AGA10	1,344	GB	78
58	1.30	842	1000	30:1	56C	GF3024AGA10	1,344	GB	78
44	1.20	1053	1100	40:1	56C	GF4024AGA10	1,344	GB	78
35	1.70	1131	1300	50:1	56C	GF5030AGA10	1,814	GB	106
29	1.50	1196	1300	60:1	56C	GF6030AGA10	1,814	GB	106
TEFC, 3 Phase, 230/460 Volt									
350	1.10	149	240	5:1	56C	GF0513AGB10	924	GB	50
175	1.50	285	600	10:1	56C	GF1018AGB10	973	GB	60
117	1.35	491	750	15:1	56C	GF1521AGB10	1,111	GB	65
88	1.70	603	1000	20:1	56C	GF2024AGB10	1,235	GB	70
70	1.40	730	1000	25:1	56C	GF2524AGB10	1,235	GB	70
58	1.30	842	1000	30:1	56C	GF3024AGB10	1,235	GB	70
44	1.20	1053	1100	40:1	56C	GF4024AGB10	1,235	GB	70
35	1.70	1131	1300	50:1	56C	GF5030AGB10	1,705	GB	98
29	1.50	1196	1300	60:1	56C	GF6030AGB10	1,705	GB	98
TENV, DC SCR, 90 Volt									
350	1.10	149	240	5:1	56C	GF0513AGC10	1,625	GB	64
175	1.50	285	600	10:1	56C	GF1018AGC10	1,674	GB	74
117	1.35	491	750	15:1	56C	GF1521AGC10	1,813	GB	79
88	1.70	603	1000	20:1	56C	GF2024AGC10	1,937	GB	84
70	1.40	730	1000	25:1	56C	GF2524AGC10	1,937	GB	84
58	1.30	842	1000	30:1	56C	GF3024AGC10	1,937	GB	84
44	1.20	1053	1100	40:1	56C	GF4024AGC10	1,937	GB	84
35	1.70	1131	1300	50:1	56C	GF5030AGC10	2,406	GB	112
29	1.50	1196	1300	60:1	56C	GF6030AGC10	2,406	GB	112
TENV, DC SCR, 180 Volt									
350	1.10	149	240	5:1	56C	GF0513AGD10	1,625	GB	64
175	1.50	285	600	10:1	56C	GF1018AGD10	1,674	GB	74
117	1.35	491	750	15:1	56C	GF1521AGD10	1,813	GB	79
88	1.70	603	1000	20:1	56C	GF2024AGD10	1,937	GB	84
70	1.40	730	1000	25:1	56C	GF2524AGD10	1,937	GB	84
58	1.30	842	1000	30:1	56C	GF3024AGD10	1,937	GB	84
44	1.20	1053	1100	40:1	56C	GF4024AGD10	1,937	GB	84
35	1.70	1131	1300	50:1	56C	GF5030AGD10	2,406	GB	112
29	1.50	1196	1300	60:1	56C	GF6030AGD10	2,406	GB	112

NOTE: *See page 297 for 900 Series features.

Gearmotors and Gear Products

Motor Accessories

PT Components

Grinders

Baldor Mod Express

ABB Mod Express

Product Index

1-1/2 Horsepower Stock Gear-Motors



Baldor has pre-selected and assembled our stock 900 Series* speed reducers to our most stock popular single-phase, three-phase and DC Industrial motors. These pre-assembled *Gear-Motors* offer a variety of output torques and output speeds to fit most industrial applications. To order, select the desired output speed and torque, then choose the corresponding Baldor catalog number. Your *Gear-Motor* will ship in one package, pre-assembled from the factory within 48 hours.

RPM	Service Factor	Output Torque In. Lbs.	Max. Overhung Load Rating	Ratio	NEMA Input	Catalog Number	List Price	Mult. Sym.	Ap'x. Shpg. Wgt.
TEFC, 1 Phase 115/230 Volt									
350	1.30	240	600	5:1	56C	GF0518AGA15	1,151	GB	77
175	1.30	468	750	10:1	56C	GF1018AGA15	1,151	GB	77
117	1.40	705	1000	15:1	56C	GF1524AGA15	1,414	GB	87
88	1.10	905	1000	20:1	56C	GF2024AGA15	1,414	GB	87
58	1.60	1201	1300	30:1	56C	GF3030AGA15	1,884	GB	115
44	1.20	1598	1300	40:1	56C	GF4030AGA15	1,884	GB	102
35	1.20	1940	1500	50:1	140TC	GF5032AGA15	1,992	GB	134
29	1.60	1880	2000	60:1	140TC	GF6038AGA15	2,300	GB	173
TEFC, 3 Phase, 230/460 Volt									
350	1.30	240	600	5:1	56C	GF0518AGB15	1,024	GB	64
175	1.30	468	750	10:1	56C	GF1018AGB15	1,024	GB	64
117	1.40	705	1000	15:1	56C	GF1524AGB15	1,287	GB	74
88	1.10	905	1000	20:1	56C	GF2024AGB15	1,287	GB	74
58	1.60	1201	1300	30:1	56C	GF3030AGB15	1,757	GB	102
44	1.20	1598	1300	40:1	56C	GF4030AGB15	1,757	GB	102
35	1.20	1940	1500	50:1	56C	GF5032AGB15	1,865	GB	127
29	1.60	1880	2000	60:1	56C	GF6032AGB15	1,865	GB	121
TENV, DC SCR, 180 Volt									
350	1.30	240	600	5:1	140TC	GF0518BGD15	2,620	GB	97
175	1.30	468	750	10:1	140TC	GF1018BGD15	2,620	GB	97
117	1.40	705	1000	15:1	140TC	GF1524BGD15	2,883	GB	107
88	1.10	905	1000	20:1	140TC	GF2024BGD15	2,883	GB	107
70	1.20	1133	1100	25:1	140TC	GF2526BGD15	3,013	GB	122
58	1.60	1201	1300	30:1	140TC	GF3030BGD15	3,352	GB	135
44	1.20	1598	1300	40:1	140TC	GF4030BGD15	3,352	GB	135
35	1.20	1940	1500	50:1	140TC	GF5032BGD15	3,461	GB	154
29	1.60	1880	2000	60:1	140TC	GF6038BGD15	3,769	GB	193

NOTE: *See page 297 for 900 Series features.

**Universal Series –
Right Angle – Quill
Type – Solid Shaft**



GSF2018AA Shown

1.33 thru 3.50 CD

56C thru 180TC

Applications: Ideal for conveyors, material handling, textile machines, packaging machinery. etc. (slow speed and high torque).

Features: Heavy duty cast iron housings, forged bronze worm gears, hardened steel worms, ball bearing on input shaft, tapered roller bearings on output shaft. Integral heavy duty mounting feet cast on top and bottom of housing. Single output shaft, right hand facing input shaft. Pre-lubricated with Klubersynth UH1-6-460.

Nominal Output RPM @ 1750 RPM In	Gear Ratio	Continuous Duty Output Torque (In-Lbs) Based on 1750 RPM Motor										Max Input Hp	Max Output Torque Rating In-Lbs	NEMA Motor Mount	Style Number	Catalog Number	List Price	Mult. Sym.	Ap'x Shpg. Wgt.
		0.18	0.25	0.33	0.5	0.75	1	1.5	2	3	5								
175	10:1			109	163							0.64	207	56C	STF-133-10-A-A	GSF1013AA	629	GB	21
						245	327					1.22	396	56C	STF-175-10-A-A	GSF1018AA	689	GB	22
						245	327					1.22	396	140TC	STF-175-10-B-A	GSF1018BA	689	GB	23
						244	325	488				1.77	572	56C	STF-200-10-A-A	GSF1020AA	821	GB	30
							325	488				1.77	572	140TC	STF-200-10-B-A	GSF1020BA	821	GB	29
							325	488	651			2.44	788	140TC	STF-225-10-B-A	GSF1023BA	932	GB	32
								488	651			3.43	1109	140TC	STF-258-10-B-A	GSF1026BA	1,188	GB	49
									651	976		3.43	1109	180TC	STF-258-10-C-A	GSF1026CA	1,188	GB	55
117	15:1			119	159							0.46	221	56C	STF-133-15-A-A	GSF1513AA	629	GB	21
				159	239	359						0.87	416	56C	STF-175-15-A-A	GSF1518AA	689	GB	23
					238	357	475					1.28	605	56C	STF-200-15-A-A	GSF1520AA	821	GB	29
					359	478	717					1.84	875	56C	STF-225-15-A-A	GSF1523AA	932	GB	34
						478	717					1.84	875	140TC	STF-225-15-B-A	GSF1523BA	932	GB	33
							478	717	956			2.50	1188	140TC	STF-258-15-B-A	GSF1526BA	1,188	GB	51
								717	956			3.25	1544	140TC	STF-300-15-B-A	GSF1530BA	1,357	GB	57
									717	956	1434	3.25	1544	180TC	STF-300-15-C-A	GSF1530CA	1,357	GB	61
88	20:1		102	154	205							0.36	220	56C	STF-133-20-A-A	GSF2013AA	629	GB	20
				205	308							0.68	419	56C	STF-175-20-A-A	GSF2018AA	689	GB	23
					308	462	616					1.00	612	56C	STF-200-20-A-A	GSF2020AA	821	GB	30
					308	462	616					1.00	612	140TC	STF-200-20-B-A	GSF2020BA	821	GB	28
					309	463	617					1.35	8.28	56C	STF-225-20-A-A	GSF2023AA	932	GB	34
					309	463	617					1.35	8.28	140TC	STF-225-20-B-A	GSF2023BA	932	GB	33
						461	615	923				1.92	1174	56C	STF-258-20-A-A	GSF2026AA	1,188	GB	51
							615	923				1.92	1174	140TC	STF-258-20-B-A	GSF2026BA	1,188	GB	51
								615	923	1230		2.52	1541	140TC	STF-300-20-B-A	GSF2030BA	1,357	GB	57
									923	1230		2.52	1541	180TC	STF-300-20-C-A	GSF2030CA	1,357	GB	62
										1230	1845	3.89	2363	180TC	STF-350-20-C-A	GSF2035CA	1,862	GB	93

NOTE: Service Class I Torque Ratings (1.0 Service Factor) See notes on inside back flap.
 Service Class II Torque Ratings (≥ 1.4 Service Factor)
 Service Class III Torque Ratings (≥ 2.0 Service Factor)

Vertical motor below gearhead not recommended.
 Avoiding those positions where the high speed oil seal is immersed in oil, will provide greater security against high speed input seal wear.

Gearmotors and Gear Products

Motor Accessories

PT Components

Grinders

Baldor Mod Express

ABB Mod Express

Product Index

Universal Series – Right Angle – Quill Type – Solid Shaft continued...

Nominal Output RPM @ 1750 RPM In	Gear Ratio	Continuous Duty Output Torque (In-Lbs) Based on 1750 RPM Motor										Max Input Hp	Max Output Torque Rating In-Lbs	NEMA Motor Mount	Style Number	Catalog Number	List Price	Mult. Sym.	Ap'x Shpg. Wgt.
		0.18	0.25	0.33	0.5	0.75	1	1.5	2	3	5								
70	25:1	123	186									0.29	218	56C	STF-133-25-A-A	GSF2513AA	629	GB	21
			186	247	371							0.55	406	56C	STF-175-25-A-A	GSF2518AA	689	GB	23
				247	371	557						0.81	601	56C	STF-200-25-A-A	GSF2520AA	821	GB	29
					375	563	751					1.09	814	56C	STF-225-25-A-A	GSF2523AA	932	GB	33
							744	1114	1489			2.08	1539	140TC	STF-300-25-B-A	GSF2530BA	1,357	GB	56
58	30:1	145	218								0.24	214	56C	STF-133-30-A-A	GSF3013AA	629	GB	21	
			218	289							0.47	406	56C	STF-175-30-A-A	GSF3018AA	689	GB	22	
				289	435	652					0.77	665	56C	STF-200-30-A-A	GSF3020AA	821	GB	30	
					435	652					0.98	847	56C	STF-225-30-A-A	GSF3023AA	932	GB	33	
						435	652	869			1.35	1166	56C	STF-258-30-A-A	GSF3026AA	1,188	GB	50	
							869	1304			1.74	1501	140TC	STF-300-30-B-A	GSF3030BA	1,357	GB	57	
44	40:1										2.82	2443	140TC	STF-350-30-B-A	GSF3035BA	1,862	GB	90	
		181									0.19	206	56C	STF-133-40-A-A	GSF4013AA	629	GB	21	
		180	272	362							0.36	389	56C	STF-175-40-A-A	GSF4018AA	689	GB	11	
			272	362	543						0.52	568	56C	STF-200-40-A-A	GSF4020AA	821	GB	30	
				364	547						0.71	772	56C	STF-225-40-A-A	GSF4023AA	932	GB	33	
					545	817	1090				1.01	1095	56C	STF-258-40-A-A	GSF4026AA	1,188	GB	51	
					542	815	1087				1.36	1470	56C	STF-300-40-A-A	GSF4030AA	1,357	GB	57	
35	50:1										1.36	1470	140TC	STF-300-40-B-A	GSF4030BA	1,357	GB	54	
						1087	1630	2173			2.24	2405	140TC	STF-350-40-B-A	GSF4035BA	1,862	GB	87	
		210									0.15	191	56C	STF-133-50-A-A	GSF5013AA	629	GB	21	
		210	316								0.28	360	56C	STF-175-50-A-A	GSF5018AA	689	GB	23	
		211	317	423							0.42	536	56C	STF-200-50-A-A	GSF5020AA	821	GB	30	
			317	422							0.55	693	56C	STF-225-50-A-A	GSF5023AA	932	GB	33	
29	60:1										0.79	995	56C	STF-258-50-A-A	GSF5026AA	1,188	GB	51	
					422	634	951			1.07	1350	140TC	STF-300-50-B-A	GSF5030BA	1,357	GB	57		
						634	952	1270		1.75	2196	140TC	STF-350-50-B-A	GSF5035BA	1,862	GB	89		
						952	1270	1904											
		235									0.24	343	56C	STF-175-60-A-A	GSF6018AA	689	GB	23	
29	60:1	234	353	470							0.36	505	56C	STF-200-60-A-A	GSF6020AA	821	GB	29	
			346	461	692						0.51	702	56C	STF-225-60-A-A	GSF6023AA	932	GB	33	
				470	706						0.69	976	56C	STF-258-60-A-A	GSF6026AA	1,188	GB	51	
					706	1059					0.84	1179	56C	STF-300-60-A-A	GSF6030AA	1,357	GB	56	
						1059	1413	2119			1.50	2128	140TC	STF-350-60-B-A	GSF6035BA	1,862	GB	89	

NOTE: Service Class I Torque Ratings (1.0 Service Factor)
 Service Class II Torque Ratings (≥ 1.4 Service Factor)
 Service Class III Torque Ratings (≥ 2.0 Service Factor)

Optional Shaft Positions, Bases Installation and Motor Mounting available through Mod Express.
 Refer to Baldor District Office for Price and Delivery.
 See notes on inside back flap.

Vertical motor below gearhead not recommended.

Avoiding those positions where the high speed oil seal is immersed in oil, will provide greater security against high speed input seal wear.

Inline Helical

4 Sizes

56C thru 250TC



Applications: Ideal for conveyors, material handling, textile machines, packaging machinery. etc. (slow speed and high torque).

Features: Baldor's new ILH (in-line helical) gearboxes have higher torque ratings in a compact design. Clamp collar 56C – 250TC offers compact C-face solution. Heavy-duty cast iron housings, hardened and ground AGMA class 11 gears for greater impact resistance and longer service life. Pre-fill for horizontal mounting to insure proper oil grade and fill level.

Nominal RPMs	Continuous Duty Output Torque (in-lbs.) Based on 1750 RPM Motors											Max Input Hp	Max Output Torque Rating In-Lbs.	NEMA	Style Number	Catalog Number	List Price	Mult. Sym.	Ap'x. Shpg. Wgt.		
	0.33	0.50	0.75	1	1.5	2	3	5	7.5	10	15									20	
180				349	524	698							2.02	705	56C	HB382CN56C-9	GIF0938A	998	GB	29	
				524	699	1048							4.86	1698	140TC	HB382CN140TC-9	GIF0938B	998	GB	31	
				524	699	1048							4.86	1698	180TC	HB382CN180TC-9	GIF0938C	1,093	GB	32	
							1055	1758	2637					8.79	3090	180TC	HB482CN180TC-9	GIF0948C	1,578	GB	55
										3504	5256	7007		20.17	7067	210TC	HB682CN210TC-9	GIF0968D	2,472	GB	101
124				510	766	1021							2.02	1031	56C	HB382CN56C-14	GIF1438A	998	GB	29	
				766	1021	1532							3.77	1925	140TC	HB382CN56C-14	GIF1438B	998	GB	31	
					1057	1586	2644						6.68	3532	180TC	HB482CN180TC-14	GIF1448C	1,578	GB	55	
								2447	3670	4894				10.36	5070	180TC	HB682CN180TC-14	GIF1468C	2,472	GB	93
								2447	3670	4894				14.47	7081	210TC	HB682CN210TC-14	GIF1468D	2,472	GB	101
										5268	7902	10536		27.6	14540	250TC	HB882CN250TC-14	GIF1488E	3,810	GB	229
102			468	623	935								1.84	1147	56C	HB382CN56C-18	GIF1838A	998	GB	29	
				936	1248	1872							3.12	1947	140TC	HB382CN140TC-18	GIF1838B	998	GB	31	
				1264	1896								4.86	3071	140TC	HB482CN140TC-18	GIF1848B	1,384	GB	54	
				1264	1896	3162							5.91	3738	180TC	HB482CN180TC-18	GIF1848C	1,578	GB	85	
							1776	2961	4441					9.95	5892	180TC	HB682CN180TC-18	GIF1868C	2,472	GB	93
								2963	4444	5926				11.95	7081	210TC	HB682CN210TC-18	GIF1868D	2,472	GB	101
										6219	9329	12438		23.91	14870	250TC	HB882CN250TC-18	GIF1888E	3,810	GB	229
70		440	660	880									1.41	1241	56C	HB382CN56C-25	GIF2538A	998	GB	29	
			881	1321	1762								2.21	1947	140TC	HB382CN140TC-25	GIF2538B	998	GB	31	
				1435	1913	2869							3.92	3749	140TC	HB482CN140TC-25	GIF2548B	1,384	GB	54	
				1910	2865								4.17	3983	180TC	HB482CN180TC-25	GIF2548C	1,578	GB	55	
							2759	4598	6897					7.70	7081	180TC	HB682CN180TC-25	GIF2568C	2,472	GB	93
										6755	9007	13510		16.51	14870	210TC	HB882CN210TC-25	GIF2588D	3,589	GB	178
										6755	9007	13510		16.51	14870	250TC	HB882CN250TC-25	GIF2588E	3,810	GB	229
44	465	705	1057										0.95	1339	56C	HB382CN56C-40	GIF4038A	998	GB	29	
		746	1118	1491									1.12	1670	56C	HB482CN56C-40	GIF4048A	1,384	GB	52	
				1486	2229	2972							2.68	3983	140TC	HB482CN140TC-40	GIF4048B	1,384	GB	54	
							2718	4077	6796				5.21	7081	180TC	HB682CN180TC-40	GIF4068C	2,472	GB	93	
										6710	10065	13421		11.08	14870	210TC	HB882CN210TC-40	GIF4088D	3,589	GB	178
33	691	1047	1570										0.93	1947	56C	HB383CN56C-56	GIF5638A	1,205	GB	29	
				1509	2012	3017							1.98	3983	56C	HB483CN56C-56	GIF5648A	1,518	GB	52	
							2601	3468	5203				3.04	5272	140TC	HB682CN140TC-50	GIF5068B	2,279	GB	92	
										3655	5483	9138		5.58	10198	180TC	HB882CN180TC-50	GIF5088C	3,589	GB	178

NOTE: Service Class I Torque Ratings (1.0 Service Factor)
 Service Class II Torque Ratings (≥ 1.4 Service Factor)
 Service Class III Torque Ratings (≥ 2.0 Service Factor)

**Ratio Multiplier –
Inline – Quill Type
Solid Shaft**

2 Sizes

56C thru 140TC

Applications: Reducer or Increaser*. Combine with Right Angle units for high ratios. May also be used as a stand alone with optional base kits.

Features: High efficiency. Cast iron construction, universal mounting positions, and optional base mounting. Internal compression chamber eliminates breather vent. Lubricated for life with Klubersynth GH6-150.

* Custom style "SX" can be back driven to increase motor speed. Max output speed, 4500 RPMS.



Size	Output RPM @ 1750 RPM in.	Gear Ratio	Input Style	Output Style	Catalog Number	List Price	Mult. Sym.	Ap'x. Shpg. Wgt.	Type
1	875	2:1	56C	56C	GCF2X01AA	459	GB	17	FX1-2-B5-56C
	583	3:1	56C	56C	GCF3X01AA	459	GB	17	FX1-3-B5-56C
	438	4:1	56C	56C	GCF4X01AA	459	GB	17	FX1-4-B5-56C
	350	5:1	56C	56C	GCF5X01AA	459	GB	19	FX1-5-B5-56C
2	875	2:1	140TC	140TC	GCF2X02BB	553	GB	28	FX2-2-B7-140TC
	583	3:1	140TC	140TC	GCF3X02BB	553	GB	28	FX2-3-B7-140TC
	438	4:1	140TC	140TC	GCF4X02BB	553	GB	29	FX2-4-B7-140TC
	350	5:1	56C	140TC	GCF5X02AB	553	GB	29	FX2-5-B5-140TC
	350	5:1	140TC	140TC	GCF5X02BB	553	GB	28	FX2-5-B7-140TC

Ratings at 1750 RPM Input

Size	Ratio	Output RPM	Input Hp	Output Hp	Output Torque	Output Shaft OHL
1	2:1	875	2.06	1.96	141	173
	3:1	583	1.70	1.62	175	203
	4:1	438	1.50	1.42	205	224
	5:1	350	1.13	1.08	194	247
2	2:1	875	12.42	12.17	877	445
	3:1	583	8.68	8.42	911	445
	4:1	438	6.34	6.15	885	445
	5:1	350	5.40	5.17	931	360



BRMX01 with Style SX1 Ratio Multiplier

Optional Base Kit

Size	Catalog Number	List Price	Mult. Sym.	Ap'x. Shpg. Wgt.
1	BRMX01	67	A8	6
2	BRMX02	117	A8	2



Ratio Multiplier with F900 Series Reducer

**900 Series –
Right Angle
Base Kits**



Horizontal Base



J Base



Vertical Base



Washdown Base

**Universal
Series –
Right Angle
Base Kits**



Base Description	Size (Position)	Catalog Number	List Price	Mult. Sym.	Ap'x. Shpg. Wgt.
HORIZ.	913 (A,B)	B13H71	67	A8	5
VERT. low	913 (D,F)	B13V81	117	A8	2
VERT. high	913 (C,E)	B13V91	118	A8	3
VERT. J	913 (X,Y)	B13J92	115	A8	3
HORIZ.	915 (A,B)	B15H71	47	A8	3
VERT. low	915(D,F)	B18V81	121	A8	3
VERT. high	915 (C,E)	B18V91	122	A8	3
VERT. J	915 (X,Y)	B18J92	118	A8	6
HORIZ.	918 (A,B)	B18H71	81	A8	6
VERT. low	918 (D,F)	B18V81	121	A8	3
VERT. high	918 (C,E)	B18V91	122	A8	3
VERT. J	918 (X,Y)	B18J92	118	A8	6
HORIZ.	921G (A,B)	B21GH71	84	A8	5
HORIZ.	921 (A,B)	B21H71	87	A8	6
VERT. low	921 (D,F)	B21V81	132	A8	4
VERT. high	921 (C,E)	B21V91	136	A8	6
VERT. J	921 (X,Y)	B21J92	132	A8	7
HORIZ.	924 (A,B)	B24H71	105	A8	8
VERT. low	924 (D,F)	B24V81	148	A8	4
VERT. high	924 (C,E)	B24V91	160	A8	6
VERT. J	924 (X,Y)	B24J92	148	A8	9
HORIZ.	926 (A,B)	B26H71	117	A8	9
VERT. low	926 (D,F)	B26V81	199	A8	6
VERT. high	926 (C,E)	B26V91	202	A8	9
VERT. J	926 (X,Y)	B26J92	199	A8	10
HORIZ.	930 (A,B)	B30H71	133	A8	4
VERT. low	930 (D,F)	B30V81	199	A8	8
VERT. high	930 (C,E)	B30V91	202	A8	16
HORIZ.	932 (A,B)	B32H71	158	A8	13
VERT. low	932 (D,F)	B32V81	234	A8	10
VERT. high	932 (C,E)	B32V91	240	A8	13
HORIZ.	938 (A,B)	B38H71	189	A8	15
VERT. low	938(D,F)	B38V81	281	A8	38
VERT. high	938(C,E)	B38V91	295	A8	36
Optional Washdown Base Kits					
HORIZ.	913 (A,B)	WDB13H71	87	A8	3
HORIZ.	915 (A,B)	WDB15H71	87	A8	4
HORIZ.	918 (A,B)	WDB18H71	108	A8	6
HORIZ.	921 (A,B)	WDB21H71	114	A8	6
HORIZ.	924 (A,B)	WDB24H71	123	A8	8
HORIZ.	926 (A,B)	WDB26H71	139	A8	9
HORIZ.	930 (A,B)	WDB30H71	154	A8	6
HORIZ.	932 (A,B)	WDB32H71	181	A8	13
Optional Stainless Steel Base Kits					
HORIZ.	918 (A,B)	SSB18H71	395	A8	8
HORIZ.	921 (A,B)	SSB21H71	411	A8	10
HORIZ.	926 (A,B)	SSB26H71	454	A8	13

•Kit includes angle bases and hardware. Converts style STF to SVF.

Size	HEMMA Flange	Catalog Number	List Price	Mult. Sym.	Ap'x. Shpg. Wgt
133-175	56C/140TC	B1317V81	118	A8	2
200-225	56C/140TC	B2022V81	123	A8	3
258-300	56C/140TC	B2530V81	191	A8	4
258-300	180TC	B2530V81	191	A8	4
350	56C/140TC 180TC/210TC	B3500V81	221	A8	5

Gearmotors and
Gear Products

Motor
Accessories

PT Components

Grinders

Baldor
Mod Express

ABB
Mod Express

Product
Index

NEMA C-Face Flange Kits (coupling type)

Flange adapts NEMA C face motors to 900 Series type S reducers.
Includes flange, flexible coupling and mounting hardware.



Size	NEMA Flange	Catalog Number	List Price	Mult. Sym.	Ap'x. Shpg. Wgt
913	56C	SFL913B5	183	A8	8
915	56C	SFL918B5	183	A8	9
	140TC	SFL918B7	183	A8	8
918	56C	SFL918B5	183	A8	9
	140TC	SFL921B5	203	A8	11
921	56C	SFL921B7	203	A8	11
	140TC	SFL924B5	203	A8	11
924	56C	SFL924B7	203	A8	11
	140TC	SFL926B5	261	A8	14
926	56C	SFL926B7	261	A8	15
	140TC	SFL926B7	261	A8	15

Riser Block Kits

Riser Blocks permit the gearbox to be mounted in the most desirable position (high speed input shaft above the oil level). They mount on top of the gearbox to provide clearance between the motor and the mounting surface. Kit includes the Riser Block and attachment bolts.



Size	NEMA Flange	Catalog Number	List Price	Mult. Sym.	Ap'x. Shpg. Wgt
913	56C	RBK13B5	69	A8	5
915	56C/140TC	RBK15B5	87	A8	5
918	56C/140TC	RBK18B5	108	A8	5
921	56C/140TC	RBK21B5	139	A8	5
924	56C/140TC	RBK24B5	146	A8	5
	180TC	RBK24B9	276	A8	10
926	56C/140TC	RBK26B5	154	A8	8
	180TC	RBK26B9	336	A8	11
930	56C/140TC	RBK30B5	174	A8	15
	180TC	RBK30B9	373	A8	15
932	56C/140TC	RBK32B5	234	A8	8
	180TC	RBK32B9	461	A8	15

Torque Arm Kits

Kit includes turnbuckle and both mounting brackets.
Secures hollow shaft reducer to application.



Size	Catalog Number	List Price	Mult. Sym.	Ap'x. Shpg. Wgt.
913	TA13HK	170	A8	2
918	TA18HK	188	A8	2
921	TA21HK	210	A8	6
924	TA24HK	211	A8	2
926	TA26HK	215	A8	2
930	TA30HK	219	A8	2
932	TA32HK	224	A8	6
938	TA38HK	234	A8	2

Output Flange Kits



Size	Catalog Number	List Price	Mult. Sym.	Ap'x. Shpg. Wgt.
913	FL13HK	110	A8	2
915	FL15HK	118	A8	6
918	FL18HK	123	A8	3
921	FL21HK	138	A8	3
924	FL24HK	196	A8	4
926	FL26HK	211	A8	6
930	FL30HK	219	A8	6
932	FL32HK	227	A8	12
938	FL38HK	235	A8	12

Bushing Kits for Hollow Shaft Reducers

Size	Shaft Diameter	Catalog Number	List Price	Mult. Sym.	Size	Shaft Diameter	Catalog Number	List Price	Mult. Sym.
918	3/4	BU100H012	139	A8	924/926	1-1/4	BU107H104	170	A8
	7/8	BU100H014	139	A8		1-5/16	BU107H105	170	A8
	15/16	BU100H015	158	A8		1.00	BU115H100	234	A8
924/926	15/16	BU107H015	170	A8	930/932	1-7/16	BU115H107	234	A8
	1	BU107H100	170	A8		1-1/2	BU115H108	234	A8
	1-1/8	BU107H102	170	A8		1-5/8	BU115H110	234	A8
	1-3/16	BU107H103	170	A8		1-11/16	BU115H111	234	A8
						1-3/4	BU115H112	234	A8

Stainless Steel Bushing

Size	Shaft Diameter	Catalog Number	List Price	Mult. Sym.
918	3/4	SSBU100H012	166	A8
918	7/8	SSBU100H014	166	A8
918	15/16	SSBU100H015	166	A8
921	15/16	SSBU104H015	105	A8
921	1	SSBU104H100	105	A8
926	15/16	SSBU107H015	199	A8
926	1	SSBU107H100	199	A8
926	1-1/8	SSBU107H102	199	A8
926	1-3/16	SSBU107H103	199	A8
926	1-1/4	SSBU107H104	199	A8
926	1-5/16	SSBU107H105	199	A8

Double Reduction Adapter Kit



900 series double reduction units may be assembled from stock single reduction units using the adapter kits.

Catalog Number	Primary Unit (a)	Secondary Unit (b)	List Price	Mult. Sym.
DR913X913B5	913	913-B5	183	A8
DR913X918B5	913	918-B5	191	A8
DR913X921B5	913	921-B5	202	A8
DR913X924B5	913	924-B5	202	A8
DR913X926B5	913	926-B5	219	A8
DR918X924B7	918	924-B7	219	A8
DR918X926B7	918	930-B7/926-B7	227	A8
DR918X932B7	918	932-B7	227	A8
DR924X938B9	924	938-B9	227	A8

NOTE: Each adapter kit consists of: 1 Adapter; 1 Seal (Installed); 1 Shim Set; 4 Screws; 1 Bearing Cup (Installed); 4 Lock Washers; and 1 Sealant Package.

(a) Any style except shaft mount
(b) F and HF styles only

Bushing Kit



Reduces bore size of Quill type input shafts from 7/8 to 5/8. Sintered metal bushing with integral internal and external keys.

Catalog Number	List Price	Mult. Sym.
133-6FBA	69	A8

Gearmotors and Gear Products

Motor Accessories

PT Components

Grinders

Baldor Mod Express

ABB Mod Express

Product Index