

A-GAGE EZ-ARRAY IO-Link Instruction Manual

Rev.B 4/13/2012
157954

26.0mm [1.02"] x



Contents

| | |
|--|-----------|
| 1 Features | 4 |
| 2 Overview | 5 |
| 2.1 System Components | 6 |
| 2.2 Features | 6 |
| 2.3 Configuration via DIP Switch or IO-Link Interface | 7 |
| 2.3.1 Outputs | 7 |
| 2.3.2 Display Invert | 7 |
| 2.4 Status Indicators | 7 |
| 2.4.1 Zone Indicators (Beams Blocked Segment) | 7 |
| 2.4.2 Three-Digit Display | 7 |
| 2.4.3 Blanking Indicator | 8 |
| 2.4.4 Electronic Configuration Indicator | 8 |
| 2.4.5 Receiver Interface Status Indicators | 8 |
| 2.5 Receiver Gray (Remote Teach) Wire | 9 |
| 2.6 Scanning Method | 10 |
| 2.6.1 Straight Scan | 11 |
| 2.6.2 Single-Edge Scan | 11 |
| 2.6.3 Double-Edge Scan | 11 |
| 2.6.4 Maximum Scan Times | 12 |
| 2.7 Gain Configuration | 12 |
| 2.8 Electronic Alignment Routine | 13 |
| 2.9 Blanking | 13 |
| 2.10 Measurement Mode Selection | 14 |
| 2.11 Analog Output Configuration | 15 |
| 2.12 Discrete Output Configuration | 15 |
| 3 Components and Specifications | 16 |
| 3.1 Sensor Models | 16 |
| 3.2 Cordsets and Connections | 17 |
| 3.3 Alignment Aids | 18 |
| 3.4 Accessory Mounting Brackets and Stands | 18 |
| 3.5 Replacement Parts | 19 |
| 3.6 Specifications | 20 |
| 3.7 Emitter and Receiver Dimensions | 21 |
| 3.8 Standard Bracket Dimensions | 22 |
| 4 Installation and Alignment | 23 |
| 4.1 Mounting the Emitter and Receiver | 23 |
| 4.2 Mechanical Alignment | 24 |
| 4.3 Hookups | 25 |
| 4.4 Optical Alignment | 26 |
| 5 Receiver User Interface | 27 |
| 5.1 Configuration DIP Switch | 27 |
| 5.1.1 Scanning Modes (S1 and S2) | 28 |
| 5.1.2 Measurement Modes (S3 and S4) | 28 |
| 5.1.3 Analog Slope (S5) | 28 |
| 5.1.4 Complementary/Alarm (S6) | 28 |
| 5.2 Alignment/Blanking Button (Electronic Alignment) | 29 |
| 5.2.1 Electronic Alignment and Blanking - Receiver Interface | 29 |
| 5.2.2 Flashing "000" on the 3-Digit Display | 29 |
| 5.3 Gain (Sensitivity Adjust) Button | 29 |
| 5.4 Inverting the 3-Digit Display | 29 |

| | |
|---|-----------|
| 5.5 Troubleshooting and Error Codes | 29 |
| 5.5.1 "Dirty" Channel Indicator | 30 |
| 6 IO-Link Interface | 31 |
| 6.1 Overview | 31 |
| 6.2 IO-Link Profile and Models | 31 |
| 6.3 Hardware Interface | 32 |
| 6.3.1 Electrical Interface | 32 |
| 6.3.2 IO-Link Master | 33 |
| 6.4 IO-Link Device Description) | 33 |
| 6.5 Configuration Data | 33 |
| 6.5.1 Scan Configuration | 33 |
| 6.5.2 Blanking Configuration | 34 |
| 6.5.3 General Configuration | 35 |
| 6.5.4 Analog Output 1 Configuration | 37 |
| 6.5.5 Analog Output 2 Configuration | 38 |
| 6.5.6 Discrete Output 1 Configuration | 39 |
| 6.5.7 Discrete Output 2 Configuration | 40 |
| 6.6 System Status and Measurement Data | 40 |
| 6.6.1 Active Measurements | 40 |
| 6.6.2 ALL Measurements | 41 |
| 6.6.3 Channel States | 42 |
| 6.6.4 System Info and Status | 43 |
| 6.6.5 Receiver and Emitter Version Info | 45 |
| 6.6.6 Communications Version Info | 45 |
| 6.6.7 Alignment/Blanking Routine | 45 |

1 Features



- A cost-effective, two-piece measuring light curtain designed for quick and simple installations with the sophistication to handle the toughest sensing applications
- Excels at high-speed, precise process monitoring and inspection, profiling, and web-guiding applications
- A comprehensive combination of scanning options:
 - 14 measurement (“scan analysis”) modes
 - 3 scanning methods
 - Selectable beam blanking
 - Selectable continuous or gated scan initiation
 - Selectable threshold setting for semi-transparent applications
 - 2 analog outputs, 2 discrete outputs
 - Communication interface via IO-Link
- Outstanding 4 meter range with 5 mm beam spacing
- Available in 12 lengths from 150 mm to 2400 mm
- Excellent 5 mm minimum object detection or 2.5 mm edge resolution, depending on scanning method
- Receiver user interface for quick, intuitive setup of many common applications:
 - 6-position DIP switch for setting scan mode, measurement mode, analog slope, discrete output 2 option (complementary measurement or alarm operation)
 - 2 push buttons for gain method selection and alignment/ blanking
 - 7 Zone LEDs for instant alignment and beam blockage information
 - 3-digit display for sensing information and diagnostics
- Advanced configuration via IO-Link communication interface
- Remote teach wire option for alignment, gain settings, inverted display, and DIP switch disable



WARNING: Not To Be Used for Personnel Protection

Never use this product as a sensing device for personnel protection. Doing so could lead to serious injury or death. This product does NOT include the self-checking redundant circuitry necessary to allow its use in personnel safety applications. A sensor failure or malfunction can cause either an energized or de-energized sensor output condition.

2 Overview

The A-GAGE™ EZ-ARRAY™ measuring light screen is ideal for such applications as on-the-fly product sizing and profiling, edge-guiding and center-guiding, loop tensioning control, hole detection, parts counting, and similar uses (see Figure 2-1).

Emitters and receivers are available with arrays from 150 to 2400mm (5.9" to 94.5") long. The emitter has a column of infrared light emitting diodes (LEDs) spaced 5mm apart; their light is collimated and directed toward the receiver, positioned opposite the emitter, which has photodiodes on the same 5mm pitch. The light from each emitter LED is detected by the corresponding receiver photodiode.

This sophisticated light curtain is capable of detecting opaque cylindrical objects as small as 5mm in diameter or measuring part edges within 2.5 mm, depending on the scanning method selected (see [Scanning Method](#)). The sensing range is 400 mm to 4 m (16" to 13').

The EZ-ARRAY's two-piece design makes it economical and easy to use. Controller functionality is built into the receiver housing. It can be configured for many straightforward applications simply by configuring the six-position DIP switch on the front of the receiver (the receiver user interface). The IO-Link communication interface provides the capability for more advanced control and monitoring. See [IO-Link Interface](#).

Installation is easy, too. The emitter and receiver housings can be side-mounted or end-cap-mounted using the included end-cap brackets; longer models also include a center bracket (see [Mounting the Emitter and Receiver](#)).

Beam synchronization is achieved via the 8-conductor sensor cables. Individual LEDs and a 3-digit diagnostic display on the receiver provide ongoing visual sensing status and diagnostic information. Comprehensive data is available to a process controller via a combination of four outputs: two analog and two discrete (discrete output 1 is an IO-Link output). The IO-Link output provides a discrete output (SIO mode) or a communication interface (IO-Link mode).

Figure 2-1. Typical A-GAGE EZ-ARRAY application

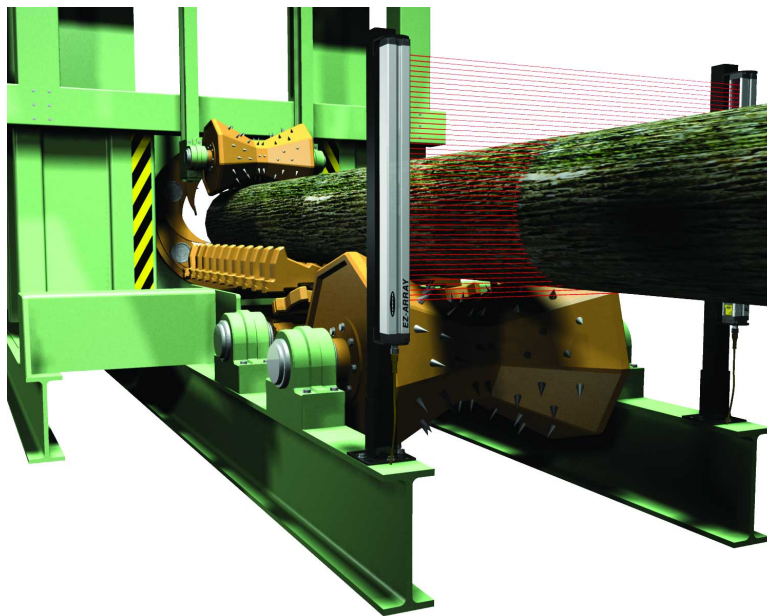

2.1 System Components

A typical A-GAGE EZ-ARRAY has four components: an emitter and a receiver, each with an integral quick-disconnect (QD) fitting, plus an 8-pin QD cordset for the emitter and for the receiver (see Figure 2-2).

For applications that use the IO-Link interface, an additional cable splitter is used to convert the receiver 8-pin connector to a compatible M12 connector.



Figure 2-2. A-GAGE EZ-ARRAY system components

2.2 Features

Built-in features in the EZ-ARRAY contribute to its ease of use. Many features are available using either the user-friendly receiver interface or the more advanced IO-Link interface.

Built-in diagnostic programming and easy-to-see indicators on the receiver simplify physical alignment and troubleshooting (Figure 2-3); more advanced diagnostics are available via the IO-Link interface.

The receiver has a bright LED that indicates overall sensing status (OK, marginal alignment, and hardware error). Two other LEDs indicate serial communication status. Seven Zone indicators each communicate the blocked / aligned status of one-seventh of the total array. A 3-digit diagnostic display provides further diagnostic information, including number of beams blocked, whether blanking is configured, and troubleshooting codes.

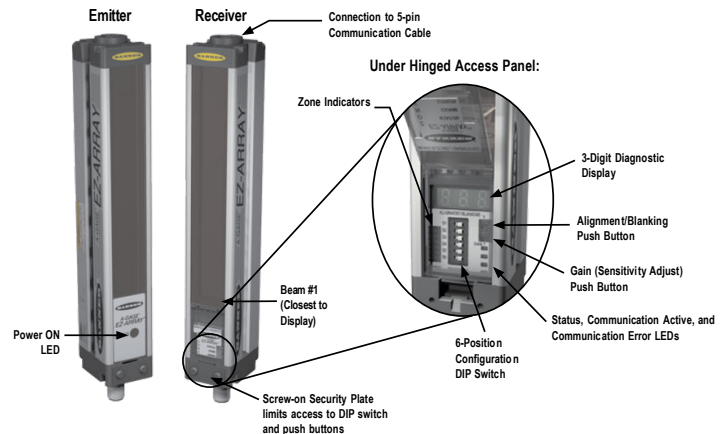

Figure 2-3. A-GAGE EZ-ARRAY features

The emitter has a red LED that signals proper operation (ON when power is applied). See [Status Indicators](#) for more information about indicators and [Troubleshooting and Error Codes](#) for display codes and troubleshooting.

The Alignment routine ([Alignment Blanking Button](#) or [Alignment Blanking Routine](#)) automatically equalizes the excess gain of each beam for reliable object detection throughout the array. This routine need not be performed again unless the sensing application changes, or if the emitter and/or receiver is moved.

Configurable beam blanking accommodates machine components and fixtures that must remain in or move through the light screen. Blanking may be set using the receiver interface, the teach wire, or the IO-Link interface.

The EZ-ARRAY light screen provides a wide selection of sensing and output options, including measurement (“scan analysis”) modes and scanning methods that can determine a target object’s location, overall size, total height, or total width, or the number of objects. Scanning may be continuous or controlled by a gate sensor.

2.3 Configuration via DIP Switch or IO-Link Interface

Commonly used configuration options can be set up easily via a six-position DIP switch located behind a hinged clear access panel on the front of the receiver.

Access to the DIP switch can be prevented by using the screw-on security plate to hold the clear access panel closed or by disabling them via the IO-Link interface.

2.3.1 Outputs

All models have two analog outputs and two discrete outputs (discrete output 1 is an IO-Link output).

The analog outputs are 0–10V voltage. They may be configured (via DIP switch or IO-Link interface) for either a positive or negative slope.

Discrete output 1 is always used for measurement; discrete output 2 may be used either for alarm or measurement operation (selectable via DIP switch or IO-Link interface). When the receiver interface is used, discrete output 1 and analog output 1 follow the same measurement mode. When the IO-Link interface is used for configuration, discrete output 2 has full configurability, including measurement mode, NPN or PNP polarity, and normally open or normally closed operation. Discrete output 1 has the same configurability as discrete output 2, except for NPN or PNP polarity. Discrete output 1 is a dedicated push-pull output.

2.3.2 Display Invert

For applications where the sensors must be mounted with the display end at the top (so that the display is not right-reading), the receiver’s diagnostic display can be inverted for easy reading, either by use of the receiver’s remote wire (*Receiver Gray (Remote Teach) Wire*) or the IO-Link interface (HW Interface Flags in *Appendix: General Configuration*).

2.4 Status Indicators

Both the emitter and receiver provide ongoing visual indication of operating and configuration status.

The emitter has a red LED that signals proper operation (ON when power is applied).

The receiver has a bright Status LED that indicates overall sensing status (OK, marginal alignment, and hardware error). Two other LEDs indicate whether communication is active or if there is an error. Seven Zone indicators each communicate the blocked/aligned status of one-seventh of the total array. A 3-digit diagnostic display provides further diagnostic information: number of beams blocked, whether blanking is configured, and troubleshooting codes. See *Troubleshooting and Error Codes* for display codes and troubleshooting.

2.4.1 Zone Indicators (Beams Blocked Segment)

Seven LEDs represent emitter/receiver alignment status. They provide a visual aid for sensor alignment and monitoring objects within the sensor’s field of view. The sensor array is partitioned into seven equal segments, each of which is represented by one of the seven LEDs. The LED closest to DIP switch S6 (see Figure 5-1) represents the group of optical channels closest to the receiver display (the “bottom” group). The LED closest to DIP switch 1 represents the far segment of channels.

These LEDs illuminate either green or red. When an LED is green, no unblanked beams are obstructed in that segment. When the LED is red, one or more beams in that segment is obstructed.

2.4.2 Three-Digit Display

The 3-digit display has slightly different functions during normal operation, alignment, and gain adjust modes. In normal operation the display indicates the current numerical value of measurement mode 1. The display also identifies the following activated sensor functions: blanking and locked-out user interface/electronic configuration, as shown in Figure 2-4. (For directions for inverting the display, see *Receiver Gray Wire* or see HW Interface Flags in *General Configuration*.)

During blanking mode, the display reads “n”, followed by the number of blocked beams in the array. During alignment mode, it reads “A”, followed by the number of blocked, unblanked beams; a period follows the A (“A.”) if blanking is configured.

During gain adjust mode, the display reads “L” followed by “1” or “2” to indicate the gain level. (A “1” represents high excess gain, and a “2” represents low contrast.)

If a sensing error occurs, the display reads “c” followed by a number that corresponds to the recommended corrective action (see [Troubleshooting and Error Codes](#)).

2.4.3 Blanking Indicator

The Blanking indicator will be visible (ON) when the blanking feature is enabled. It appears as a period following the first digit of the display.

2.4.4 Electronic Configuration Indicator

The Electronic Configuration indicator is ON when the sensor configuration is defined by the IO-Link interface, and not the DIP switch. When electronic configuration is enabled, the DIP switch is ignored.



'A' in this position indicates Alignment mode
 Period ON indicates Blanking Configured
 Period ON indicates Electronic Configuration Enabled

Figure 2-4. Indications provided by the receiver's 3-digit display

2.4.5 Receiver Interface Status Indicators

The receiver has three status indicators: green/red STATUS, yellow COMM, and red ERROR. The following table lists the indicator states.

Figure 2-5. Receiver Interface Status Indicators

| LED Indicator | Color | Explanation |
|--|--------|--|
| STATUS | Green | System is OK |
| | Red | Marginal Alignment or Hardware Error; check 3-digit display* |
| COMM | Yellow | IO-Link Mode - Indicator is flashing |
| ERROR | Red | Error: Check cabling or master controller |
| *Display shows “c”: See Troubleshooting and Error Codes . | | |
| Display shows only numbers: Low Gain/Marginal Alignment condition. See Troubleshooting and Error Codes . | | |

2.5 Receiver Gray (Remote Teach) Wire

The receiver gray (remote teach) wire is used to electronically emulate the receiver push button functions (see [Troubleshooting and Error Codes](#)) via a process controller, to disable the DIP switches for security, or to provide a gate input to initiate sensor scanning. Connect a normally open switch between the receiver's gray wire and dc common, or connect the gray wire to a digital input (PLC) and pulse the wire as indicated in Figure 2-5.



NOTE: A low level is 0 to 2 volts and a high level is 10 to 30 volts or circuit open. Input impedance is 22k.





Remote TEACH/Gate in the determines the functionality of the receiver gray wire (see Remote TEACH/Gate in [Scan Configuration](#)).



- **Disabled:** The remote wire has no function (regardless of whether it is low or high). When the gray wire is disabled, the receiver is in continuous scan mode; it begins a new scan immediately after updating the outputs from the previous scan. (Continuous scan is used in most analog output applications and whenever continuous updating of the outputs is acceptable.) The gray wire is always enabled when in DIP switch mode.
- **Remote Teach:** The gray wire provides the full Remote Teach functionality shown in Figure 2-5.
- **Alignment/Sensitivity:** This mode is an abbreviated version of Remote Teach. It can perform the alignment and sensitivity adjustment functions, but not the display inversion or DIP switch enable/disable functions.

Gate Mode options enable the gray wire to be used as a gate input pulse, typically from a dc device such as an NPN-output photoelectric sensor or a PLC discrete output.

- **Gate - Active High** - The receiver scans whenever the gate is pulled high.
- **Gate - Active Low** - The receiver scans whenever the gate is pulled low.
- **Gate - Rising Edge** - The receiver scans once for each low-to-high gate transition. (Multiple transitions cannot be faster than the sensor's response for them to be reliably detected.)
- **Gate - Falling Edge** - The receiver scans once for each high-to-low gate transition. (Multiple transitions cannot be faster than the sensor's response for them to be reliably detected.)

Figure 2-6. Remote Wire TEACH Procedures

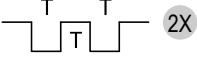
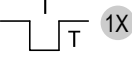
| Process | | Remote Wire Procedure $0.05 \leq \text{sec. } T \leq 0.8 \text{ sec.}$ | Result |
|----------------------|-----------------------|---|--|
| Alignment / Blanking | Access Alignment Mode |  | "A" appears on 3-digit display |
| | Access Blanking Mode | From Alignment Mode:  | "n" appears on 3-digit display, along with number of blocked beams |
| | Exit Blanking Mode |  | "A." appears on 3-digit display (sensor returns to alignment mode with blanking enabled) |
| | Exit Alignment Mode |  | Sensor returns to run mode |

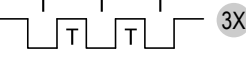
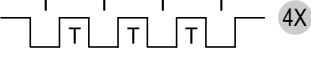
| Process | | Remote Wire Procedure $0.05 \leq \text{sec. } T \leq 0.8 \text{ sec.}$ | Result |
|-----------------------------------|-----------------------------------|--|---|
| Gain Method | Access Gain Mode | <p><i>From Run Mode:</i></p>  | "L" appears on 3-digit display, along with number "1" or "2", to designate gain level |
| | Toggle Between Gain Settings |  | Number changes from number "1" to "2", back to "1", etc. |
| | Save Gain Level and Exit | <p><i>When correct level is displayed:</i></p>  | Gain level is configured: "1" = High-excess-gain setting "2" = Low-contrast setting Sensor returns to run mode |
| Invert Display | Invert Display |  | Display inverts from previous state; sensor continues in run mode |
| Receiver Interface Enable/Disable | Receiver Interface Enable/Disable |  | <p>The factory default is <u>Receiver Interface enabled</u>.</p> <p>Four-pulsing the remote line saves the current settings and disables the interface (the sensor continues to operate using the saved settings; changes made to the DIP switch will have no effect).</p> <p>Repeating the process enables the Receiver Interface so that settings can be changed.</p> |

2.6 Scanning Method

One of three scanning methods may be configured:

- Straight Scan
- Single-edge Scan
- Double-edge Scan (1, 2, 4, 8, 16, or 32 steps)

Sensor response time is a function of sensor length and scanning method. Maximum scan times are shown in Figure 2-8.

Figure 2-7. The effect of scan mode and step size on minimum object detection size and edge resolution

| Scanning Method | Straight Scan | | Single-Edge Scan | Double-Edge Scan (per Edge) | | | | | |
|--------------------------------|---------------|------------------|------------------|-----------------------------|--------------|--------------|--------------|--------------|--------------|
| | Low-Contrast | High-Excess-Gain | | Step Size (Number of Beams) | | | | | |
| | | | | 1 | 2 | 4 | 8 | 16 | 32 |
| Minimum Object Detection Size* | 5 mm (0.2") | 10 mm (0.4") | 10mm (0.4") | 10mm (0.4") | 20mm (0.8") | 30mm (1.2") | 50mm (2") | 90mm (3.6") | 170mm (6.8") |
| Edge Resolution | 5mm (0.2") | 5mm (0.2") | 2.5mm (0.1") | 2.5mm (0.1") | 2.5mm (0.1") | 2.5mm (0.1") | 2.5mm (0.1") | 2.5mm (0.1") | 2.5mm (0.1") |

*MODS determined using a rod target object

2.6.1 Straight Scan

Straight Scan is the default mode, in which all beams are scanned in sequence, from the display end to the far end of the array. This scanning method provides the smallest object detection size. Straight scan is used when low-contrast sensitivity is selected or when single-edge and double-edge scan cannot be used. The edge resolution is 5 mm (0.2"). When low-contrast sensing is selected (used when measuring semi-transparent objects), the minimum object detection size is 5 mm (0.2") diameter. When high-excess-gain sensing is selected, the minimum object detection size is 10 mm (0.4"). See Figure 2-6.

2.6.2 Single-Edge Scan

Single-Edge Scan is used to measure the height of a single object. This scanning method is commonly used for box height measurement. For single-edge scan, the receiver always activates the first beam channel (or "bottom" beam, nearest the display). When the first beam is blocked, the sensor performs a binary search to hunt for the last beam blocked, as follows:

1. The receiver scans only the first beam until it is blocked (see Figure 2-7).
2. When the first beam is blocked, the sensor looks to see whether the middle beam is blocked or made (unblocked).
3. If the middle beam is made (unblocked), the sensor checks the bottom quarter beam; if the middle beam is blocked, the sensor checks the top quarter beam.
4. The routine continues to divide the number of beams in half until the edge is found.

Single-edge scan can be used only for single, solid objects that block the first beam (closest to the display). Because the receiver checks only the first beam until it is blocked, single-edge scan will not function when the item to be measured does not block the first beam. Single-edge scan is also ineffective if the object does not present a continuous blocked pattern.

Single-edge scan works only when the high-excess-gain setting is enabled. When single-edge scan is selected, the sensor object detection size is 10 mm and edge resolution is 2.5 mm.

2.6.3 Double-Edge Scan

Double-Edge Scan is used to detect two edges of a single object, for example, to determine box width measurements. Double-edge scan requires the selection of a step size: 1, 2, 4, 8, 16 or 32 beams. The sensor uses the steps to "skip" over beams, as follows:

1. The sensor activates beam 1 (closest to the sensor display end).
2. The sensor activates the next beam, determined by the step size. (For example, if the step size is 2, beam 3 is next; if the step size is 8, beam 9 is next.)
3. As long as the activated beam is made (unblocked), the sensor continues the stepping routine until a blocked beam is found.
4. When a blocked beam is found, a binary search is conducted to find the object's "bottom" edge.
5. When the bottom edge is found, the sensor continues to step through the array until it finds the next unblocked beam.
6. Another binary search is performed to find the second edge.

Similar to single-edge scan, double-edge scan has some restrictions: the object should provide a solid obstruction; the size of the object determines the maximum step size (Figure 2-6). Double-edge scan can be used to detect up to three objects. Like single-edge scan, double-edge scan works only when the high-excess-gain setting is selected. When double-edge scan is selected, the sensor object detection size varies, depending on the step size, but edge resolution is 2.5 mm.

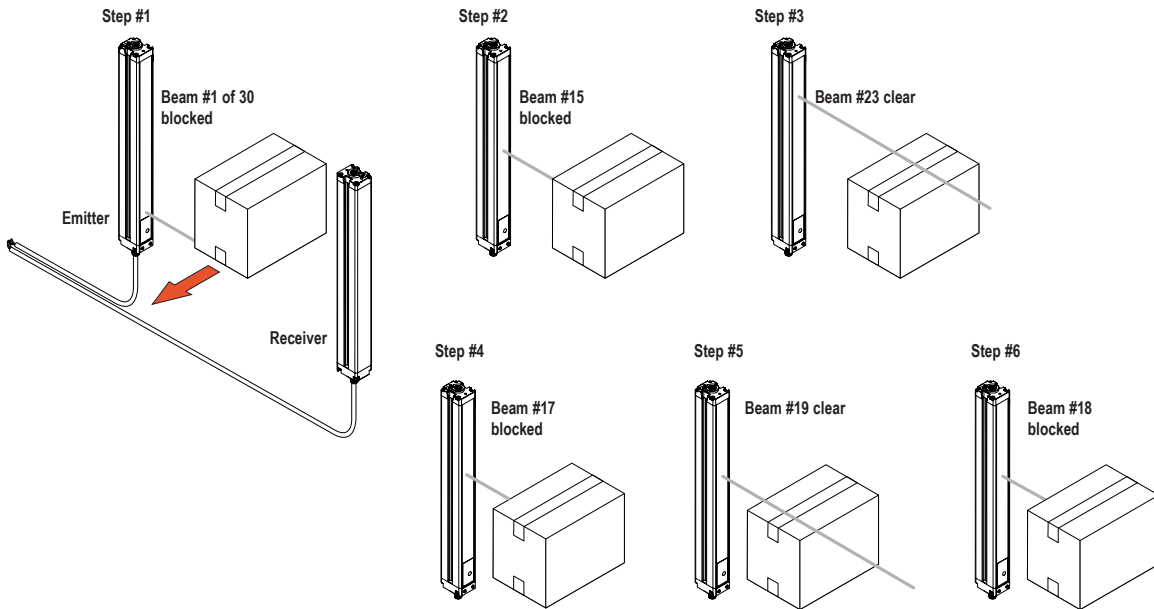

Figure 2-8. Finding an edge using a binary search (single-edge scan)

2.6.4 Maximum Scan Times

| Maximum Scan Times (in milliseconds) | | | | | | | | |
|--------------------------------------|---------------|------------------|------------------|--------------|--------------|--------------|---------------|---------------|
| Array Length | Straight Scan | Single-Edge Scan | Double-Edge Scan | | | | | |
| | | | Step 1 Beam | Step 2 Beams | Step 4 Beams | Step 8 Beams | Step 16 Beams | Step 32 Beams |
| 150 mm (5.9") | 2.8 | 1.5 | 3.4 | 2.8 | 2.5 | 2.4 | 1.9 | N/A |
| 300 mm (11.8") | 5.0 | 1.5 | 5.9 | 4.1 | 3.2 | 2.8 | 2.3 | 2.1 |
| 450 mm (17.7") | 7.1 | 1.6 | 8.5 | 5.5 | 4.2 | 4.0 | 3.2 | 2.5 |
| 600 mm (23.6") | 9.3 | 1.6 | 11.0 | 6.8 | 4.9 | 4.2 | 4.0 | 2.8 |
| 750 mm (29.5") | 11.4 | 1.7 | 13.5 | 8.1 | 5.7 | 4.6 | 4.5 | 4.5 |
| 900 mm (35.4") | 13.6 | 1.7 | 16.0 | 9.5 | 6.1 | 4.7 | 4.6 | 4.6 |
| 1050 mm (41.3") | 15.7 | 1.8 | 18.6 | 10.8 | 6.8 | 5.2 | 4.8 | 4.8 |
| 1200 mm (47.2") | 17.9 | 1.8 | 21.1 | 12.2 | 7.4 | 5.5 | 4.9 | 4.9 |
| 1500 mm (59.1") | 22.2 | 1.9 | 26.1 | 14.8 | 9.0 | 6.4 | 5.3 | 4.9 |
| 1800 mm (70.9") | 26.5 | 2.0 | 31.2 | 17.5 | 10.5 | 7.3 | 6.0 | 5.6 |
| 2100 mm (82.7") | 30.8 | 2.8 | 36.3 | 20.2 | 12.0 | 8.2 | 6.7 | 5.6 |
| 2400 mm (94.5") | 35.1 | 2.8 | 41.4 | 22.9 | 13.5 | 9.1 | 7.4 | 5.9 |

Scan times are also dependent on analog filter speed; see [Analog Output 1 Configuration](#) and [Analog Output 2 Configuration](#).

Figure 2-9. Maximum scan times for straight, single-edge and double-edge scanning

2.7 Gain Configuration

The EZ-ARRAY provides two gain options for straight scan applications: high excess gain and low contrast. The gain method can be selected using the receiver push button, the receiver remote teach wire, or the IO-Link interface.

High (maximized) excess gain is suited for detecting opaque objects and for reliable sensing in dirtier environments where objects to be detected are 10 mm or larger. The high excess gain method is always used in single- and double-edge scan. The high excess gain option has a minimum blocked threshold level, which provides reliable sensing at higher excess gain levels.

The low-contrast setting is used for sensing semi-transparent materials and for detecting objects as small as 5 mm (straight scan only). In low-contrast operation, only a portion of a beam must be blocked for detection to occur. In low-contrast operation, the sensor sets an individual threshold for each optical channel during the alignment process; this process equalizes the signal strength to allow semi-transparent object detection.

When using the IO-Link interface, low-contrast sensing provides a fine-tune sensitivity setting of 15% to 50%. When using the receiver interface, low-contrast sensitivity is always 30%.

| Gain Setting | Scan Method | EZ-ARRAY MODS* | EZ-ARRAY Resolution |
|---------------------------------------|------------------|----------------------|---------------------------------------|
| Low Contrast | Straight Scan | 5 mm | 5 mm |
| | Single-edge Scan | - | - |
| | Double-edge Scan | - | - |
| High Excess Gain | Straight Scan | 10 mm | 5 mm |
| | Single-edge Scan | 10 mm | 2.5 mm |
| | Double-edge Scan | Depends on step size | 2.5 mm / edge 5 mm total (both edges) |
| * MODS: Minimum Object Detection Size | | | |

Figure 2-10. Effects of Gain selection on minimum object detection size and sensing resolution

2.8 Electronic Alignment Routine

The objective of the optical alignment process is to adjust the emitter light level to maximize sensor performance. Perform the alignment procedure at installation and again whenever the emitter and/or receiver is moved.

During the alignment procedure, the receiver polls each beam channel to measure excess gain and performs a gain adjustment for each beam. When the system exits the alignment procedure, each channel's signal strength is stored in non-volatile memory.

The procedure can be performed using the receiver remote wire, the receiver interface push button or the IO-Link interface (see [Receiver Gray Wire](#), [Alignment/Blanking Button](#), or refer to [Alignment Blanking Routine](#)). The receiver's Alignment push button may be disabled, by configuration thru the IO-Link interface.

2.9 Blanking

If a machine fixture or other equipment blocks one or more sensing beams, the affected beam channels may be blanked. The blanking option causes the receiver to ignore the status of blanked beams for measurement mode calculations. **For example**, if a machine fixture blocks one or more beams during sensing, the output data will be incorrect; if the beams blocked by the fixture are *blanked*, the output data will be correct. Blanking may be configured using the receiver's Alignment push button, the receiver remote wire, or the IO-Link interface.

2.10 Measurement Mode Selection

The outputs may be configured for any of fourteen measurement (scan analysis) modes, which refer to specific beam locations, quantities of beams, or edge transitions. Note that not all measurement mode options are available when the receiver interface is used for configuration. Selected modes are individually assigned to each output (see [Configuration DIP Switch](#) or refer to Measurement 1 and Measurement 2 table in [General Configuration](#)).

When using the IO-Link interface for configuration, discrete output 2 can have NPN or PNP polarity (regardless of model), be normally open or normally closed, and be assigned to any of the measurement modes. Discrete output 1 has the same configuration options as discrete output 2, except for NPN or PNP polarity. Discrete output 1 is the IO-Link output and is a dedicated push-pull output. When using the receiver interface, limited output configuration combinations may be selected see ([Configuration DIP Switch](#)).



NOTE: Array beams are numbered in sequence (beam 1 located nearest the sensor display; see Figure 2-3). The "first beam" referenced in the following descriptions is the beam nearest the sensor display.

"Beam Location" Modes

First Beam Blocked (FBB)

The location of the first blocked beam.

First Beam Made (FBM)

The location of the first made (unblocked) beam.

Last Beam Blocked (LBB)

The location of the last blocked beam.

Last Beam Made (LBM)

The location of the last made beam.

Middle Beam Blocked (MBB)

The location of the beam midway between the first and last blocked beams.

"Beam Total" Modes

Total Beams Blocked (TBB)

The total number of blocked beams.

Total Beams Made (TBM)

The number of beams made.

Contiguous Beams Blocked (CBB)

The largest number of consecutively blocked beams.

Contiguous Beams Made (CBM)

The largest number of consecutively made beams.

Outside Dimension (OD)

The inclusive distance (measured in beams) from the first blocked beam to the last blocked beam.

Inside Dimension (ID)

The number of made beams, between the first and last blocked beams.

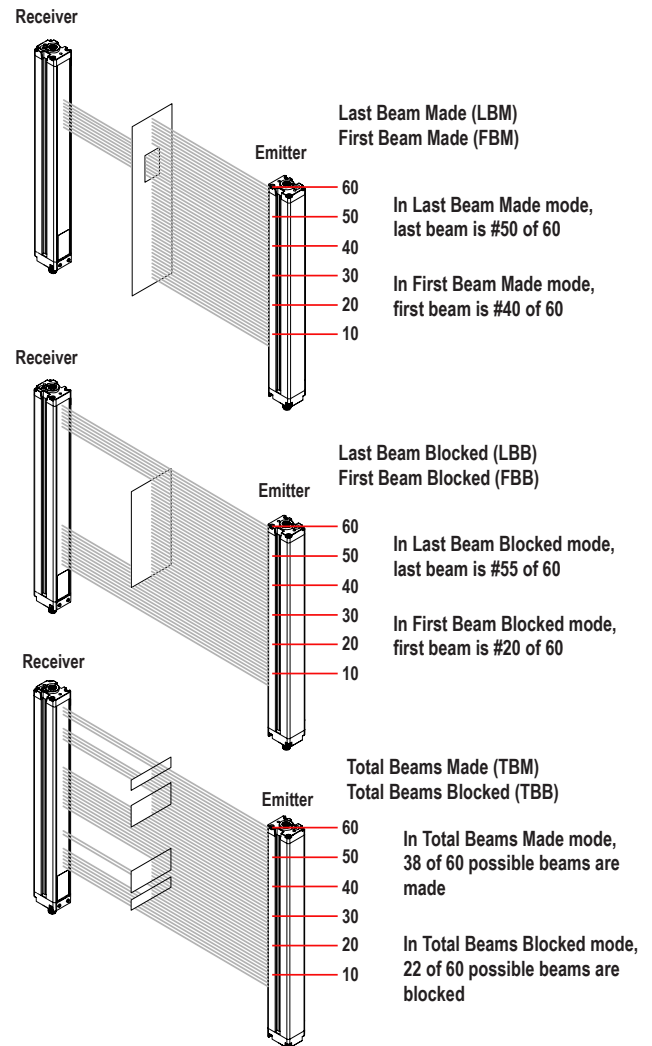

Figure 2-11. Measurement mode examples

Transitions (TRN)

The number of changes from blocked to clear status and from clear to blocked status. (If beams 6-34 are blocked, then there is a clear-to-blocked transition from beam 5 to beam 6, and a blocked-to-clear transition from beam 34 to beam 35.) Transition mode can be used to count objects within the array.

Contiguous First Beam Blocked (CFBB)

The location of the first blocked beam in the largest group of adjacent blocked beams.

Contiguous Last Beam Blocked (CLBB)

The location of the last blocked beam in the largest group of adjacent blocked beams.

Carpet Nap and Carpet Edge

These measurement modes are used to measure the location of carpet backing and tuft, and are selectable only via the IO-Link interface, and only when the Scan Type "**Carpet Nap**" is selected. The modes can be measured from either end of the sensor, but at least 10 beams (2") must be blocked from one edge.

2.11 Analog Output Configuration

Analog output configuration assigns analog outputs 1 and 2 to one of the measurement modes described in [Measurement Mode Selection](#). When the selected measurement mode involves first or last beam blocked or made (unblocked), the assigned output will vary in proportion to the beam number identified during a scan. When the measurement mode involves total beams blocked or made, that assigned output will vary in proportion to the total beams counted during a scan.

Analog outputs may have Null and Span values set in the IO-Link interface, in addition to a filter setting (to smooth the output) and Zero Value (to specify the output value when the measurement mode value is zero). Refer to [Appendix: Analog Output 1 Configuration](#) and [Analog Output 2 Configuration](#).

2.12 Discrete Output Configuration

Discrete Output 1; Receiver Interface

When the receiver interface is used for configuration, the measurement mode assigned to discrete output 1 is the same as that assigned to analog output 1.

Discrete Output 2; Receiver Interface

Discrete output 2 (only) has two options: alarm and complementary (measurement) operation.

Alarm

Output 2 energizes when the receiver detects a sensor error (such as a disconnected cable) or whenever the excess gain of one or more beams becomes marginal.

Complementary (Measurement)

Discrete output 2 operation is complementary to discrete output 1 (when output 1 is ON, output 2 is OFF, and vice versa).

Discrete Output 1 and 2 Configuration; IO-Link Interface

When the IO-Link interface is used for configuration, the discrete outputs have more options: either discrete output can be assigned to any of the measurement modes, high and low set points can be added, the outputs can be inverted, and hysteresis values can be set, as well as a scan number to smooth output performance. Discrete output 2 can be assigned to alarm mode via the IO-Link interface also. Refer to [Appendix: Discrete Output 1 Configuration](#) and [Discrete Output 2 Configuration](#).

3 Components and Specifications

3.1 Sensor Models

| Emitter/Receiver Model IO-Link | Discrete Output* | Analog Output | Array Length Y** | Total Beams |
|--|------------------|----------------------|------------------|-------------|
| EA5E150Q Emitter EA5R150XKQ Receiver | - PNP | - Voltage (0-10V) | 150mm (5.9") | 30 |
| EA5E300Q Emitter EA5R300XKQ Receiver | - PNP | - Voltage (0-10V) | 300mm (11.8") | 60 |
| EA5E450Q Emitter EA5R450XKQ Receiver | - PNP | - Voltage (0-10V) | 450mm (17.7") | 90 |
| EA5E600Q Emitter EA5R600XKQ Receiver | - PNP | - Voltage (0-10V) | 600mm (23.6") | 120 |
| EA5E750Q Emitter EA5R750XKQ Receiver | - PNP | - Voltage (0-10V) | 750mm (29.5") | 150 |
| EA5E900Q Emitter EA5R900XKQ Receiver | - PNP | - Voltage (0-10V) | 900mm (35.4") | 180 |
| EA5E1050Q Emitter EA5R1050XKQ Receiver | - PNP | - Voltage (0-10V) | 1050mm (41.3")** | 210 |
| EA5E1200Q Emitter EA5R1200XKQ Receiver | - PNP | - Voltage (0-10V) | 1200mm (47.2")** | 240 |
| EA5E1500Q Emitter EA5R1500XKQ Receiver | - PNP | - Voltage (0-10V) | 1500mm (59.1")** | 300 |
| EA5E1800Q Emitter EA5R1800XKQ Receiver | - PNP | - Voltage (0-10V) | 1800mm (70.9")** | 360 |
| EA5E2100Q Emitter EA5R2100XKQ Receiver | - PNP | - Voltage (0-10V) | 2100mm (82.7")** | 420 |
| EA5E2400Q Emitter EA5R2400XKQ Receiver | - PNP | - Voltage (0-10V) | 2400mm (94.5")** | 480 |
| *Discrete Output 1 is push-pull (IO-Link) | | | | |
| ** Models with array lengths 1050mm and longer ship with a center bracket as well as two end-cap brackets. | | | | |

3.2 Cordsets and Connections

| Quick-Disconnect Sensor Cordsets | | | | |
|----------------------------------|---|-----------------|-------|-----------------------------------|
| Model | Description | | Image | Pinout |
| MAQDC-815 | Straight female connector, 8-pin Euro-style | 5 m (15') long | | Female Connector Shown |
| MAQDC-830 | | 9 m (30') long | | |
| MAQDC-850 | | 15 m (50') long | | |

| Male M12/Euro to Female M12/Euro QD Cordsets | | | |
|--|---------------|---------------------------|---|
| Model | Length | Wire | Termination |
| DEE2R-81D | 0.3 m (1') | 8-conductor cable, 22 AWG | M12/Euro QD fitting at each end, one male, one female |
| DEE2R-83D | 0.9 m (3') | | |
| DEE2R-88D | 2.5 m (8') | | |
| DEE2R-815D | 4.6 m (15') | | |
| DEE2R-825D | 7.6 m (25') | | |
| DEE2R-830D | 7.6 m (30') | | |
| DEE2R-850D | 15.2 m (50') | | |
| DEE2R-875D | 22.9 m (75') | | |
| DEE2R-8100D | 30.5 m (100') | | |

| IO-Link Cable Splitters | | | |
|-------------------------|----------|---|---|
| Model | Length | Description | |
| CSB-M1250M1280 | 0 m (0') | 8-pin female to split 5-pin male and 8-pin female, Euro-style, straight, with shield (IO-Link pin 2 is Voltage Output 1) | <p>Technical drawing of the CSB-M1250M1280 cable splitter. It shows a side view and a top view. Dimensions include: outer diameter $\varnothing 4.5$ [1.1773], total length 35 [1.383], shield length 27 [1.063], and a distance of 17 [1.669] from the end to the split point. The top view shows a 5-pin male connector on the left and two 8-pin female connectors on the right. Pin 2 of the male connector is labeled as Voltage Output 1. Mounting holes are specified as 2X M12X1.</p> |
| CSB-M1240M1280* | 0 m (0') | 8-pin female to split 5-pin male and 8-pin female, Euro-style, straight, with shield (IO-Link pin 2 is Discrete Output 2) | <p>Technical drawing of the CSB-M1240M1280 cable splitter. It shows a side view and a top view. Dimensions include: outer diameter $\varnothing 4.5$ [1.1773], total length 35 [1.383], shield length 27 [1.063], and a distance of 17 [1.669] from the end to the split point. The top view shows a 5-pin male connector on the left and two 8-pin female connectors on the right. Pin 2 of the male connector is labeled as Discrete Output 2. Mounting holes are specified as 2X M12 X 1.</p> |

* Shipped with all EZ-ARRAY IO-Link receivers

3.3 Alignment Aids

| Model | Description |
|---------------|---|
| LAT-1-SS | Self-contained visible-beam laser tool for aligning any EZ-ARRAY emitter/receiver pair. Includes retroreflective target material and mounting clip. |
| EZA-LAT-SS | Replacement adaptor (clip) hardware for EZ-ARRAY models |
| EZA-LAT-2 | Clip-on retroreflective LAT target |
| BRT-THG-2-100 | 2" retroreflective tape, 100' |
| BT-1 | Beam Tracker |

3.4 Accessory Mounting Brackets and Stands

See [Replacement Parts](#) for standard brackets. Order one EZA-MBK-20 bracket per sensor, two per pair.

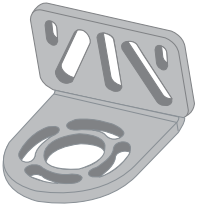
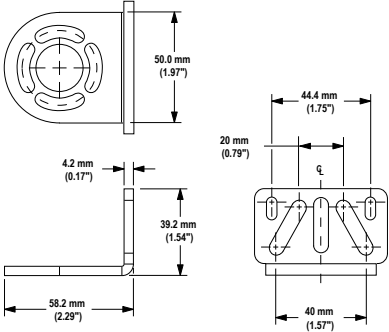
| Model | Description | | Dimensions |
|---|--|---|--|
| EZA-MBK-20 | Universal adaptor bracket pair for mounting to engineered/ slotted aluminum framing (e.g., 80/20™, Unistrut™). |  |  |
| <p>NOTE: Standard brackets shipped with sensors connect directly to MSA series stand, using hardware included with the stands.</p> | | | |

MSA Series Stands (Base Included)*

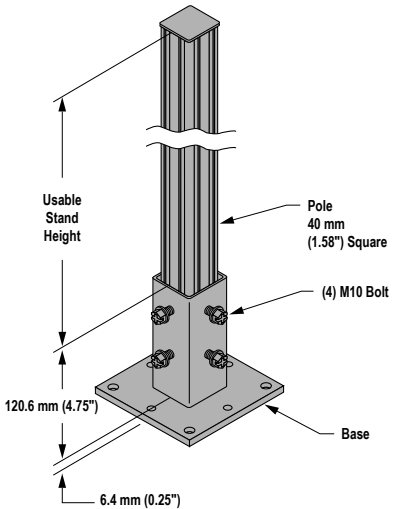
| Stand Model | Useable Stand Height | Overall Stand Height | Dimensions |
|---|----------------------|----------------------|--|
| MSA-S24-1 | 483 mm (19") | 610 mm (24") |  |
| MSA-S42-1 | 940 mm (37") | 1067 mm (42") | |
| MSA-S66-1 | 1549 mm (61") | 1676 mm (66") | |
| MSA-S84-1 | 2007 mm (79") | 2134 mm (84") | |
| <p>* Available without a base by adding suffix NB to the model number, e.g., MSA-S24-1NB.</p> | | | |

3.5 Replacement Parts

| Description | Model | |
|---|-----------------|-------------|
| Access cover with label - receiver | EA5-ADR-1 | |
| Access cover security plate (includes 2 screws, wrench) | EZA-TP-1 | |
| Wrench, security | EZA-HK-1 | |
| Standard bracket kit with hardware (includes 2 end brackets and hardware to mount to MSA Series stands) | Black | EZA-MBK-11 |
| | Stainless Steel | EZA-MBK-11N |
| Center bracket kit (includes 1 bracket and hardware to mount to MSA Series stands) | EZA-MBK-12 | |

3.6 Specifications

Emitter/Receiver Range

400 mm to 4 m (16" to 13')

Field of View

Nominally $\pm 3^\circ$

Beam Spacing

5 mm (0.2")

Light Source

Infrared LED

Minimum Object Detection Size

Straight Scan, Low-Contrast: 5 mm (0.2")

Straight Scan, High-Excess-Gain: 10 mm (0.4")

See Figure 2-5 for other scan mode values; size is tested using a rod.

Sensor Positional Resolution

Straight Scan: 5 mm (0.2")

Double-Edge Scan: 2.5 mm (0.1")

Single-Edge Scan: 2.5 mm (0.1")

Supply Voltage (Limit Values)

Emitter: 12 to 30V dc

Receiver Models: 18 to 30V dc

Supply Power Requirements

Emitter/Receiver Pair (Exclusive of Discrete Load):
Less than 9 watts

Power-up delay: 2 seconds

Teach Input (Receiver Gray Wire)

Low: 0 to 2 volts

High: 6 to 30 volts or open (input impedance 22 K ohms)

Two Discrete Outputs

Protected against false pulse on power-up and continuous overload or short circuit.

Discrete Output 1 (SIO Mode)

Type: Solid-State Push-Pull

Rating: 100 mA maximum (sourcing or sinking)

ON-State Saturation Voltage: less than 3V @ 100 mA (sourcing or sinking)

Discrete Output 2

Type: Solid-State NPN or PNP (current sinking or sourcing)

Rating: 100 mA maximum

System Configuration (Receiver Interface)

6-position DIP switch: Used to set scanning type, measurement modes, analog slope, and discrete output 2 function (see [Configuration DIP Switch](#))

Push Buttons: Two momentary push buttons for alignment and gain level selection

System Configuration (IO-Link Interface)

Supplied IODD files provide all configuration options of receiver interface, plus additional functionality; see [Overview](#) and [IO Link Device Description](#)

Status Indicators (or see [Status Indicators](#))

| IO-Link Indicators |
|---|
| Emitter: |
| Red Status LED |
| ON - Status OK |
| Flashing at 1 hz - Error |
| Receiver: |
| 7 Zone Indicators |
| Red - Blocked channels within zone |
| Green - All channels clear within zone |
| 3-digit 7-segment measurement mode/diagnostic indicator |
| STATUS: Bi-Color Indicator LED |
| Red - Hardware Error or Marginal Alignment |
| Green - OK |
| COMM: Yellow flashing indicates IO-Link mode |
| ERROR: ON Red indicates Error |

Connections

IO-Link Interface: The receiver uses a cable splitter that converts the 8-pin connector to a compatible M12 IO-Link connector; see [Cordsets and Connections](#).

Other Sensor connections: 8-conductor quick-disconnect cables (one each for emitter and receiver), ordered separately; see [Cordsets and Connections](#) for available lengths (may not exceed 75 meters long), PVC-jacketed cables measure 5.8 mm diameter, have shield wire; 22-gauge conductors

Construction

OFF-State Leakage Current: NPN: less than 200 uA @ 30V dc; PNP: less than 10 uA @ 30V dc

ON-State Saturation Voltage: NPN: less than 1.6V @ 100 mA; PNP: less than 2.0V @ 100 mA

Two Analog Outputs

Voltage Sourcing: 0 to 10V (maximum current load of 5 mA)

IO-Link Interface

Baud Rate: 38,400 bps (COM2)

Process Data Width: 16 bits

Scan Time

Scan times depend on scan mode and sensor length. Straight scan times range from 2.8 to 26.5 ms. See Figure 2-8 for all combinations.

Aluminum housing with clear-anodized finish

Acrylic lens cover

Environmental Rating

IEC IP65

Operating Conditions

Temperature: -40° to +70° C (-40° to +158° F)

Maximum relative humidity: 95% at 50° C (non-condensing)

Certifications



3.7 Emitter and Receiver Dimensions

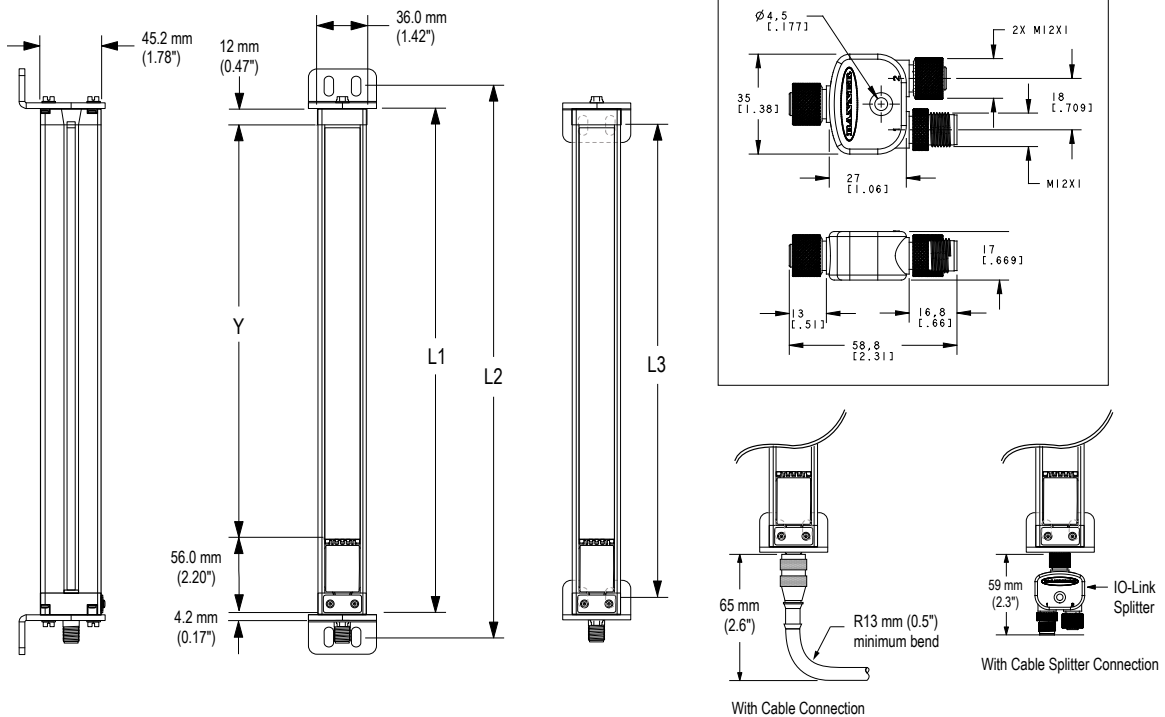

| Emitter or Receiver Model | Housing Length L1 | Distance Between Bracket Holes L2 L3 | | Defined Area Y |
|---------------------------|-------------------|--------------------------------------|-----------------|-----------------|
| EA5..150.. | 227 mm (8.9") | 260 mm (10.2") | 199 mm (7.8") | 150 mm (5.9") |
| EA5..300.. | 379 mm (14.9") | 412 mm (16.2") | 351 mm (13.8") | 300 mm (11.8") |
| EA5..450.. | 529 mm (20.8") | 562 mm (22.1") | 501 mm (19.7") | 450 mm (17.7") |
| EA5..600.. | 678 mm (26.7") | 704 mm (27.7") | 650 mm (25.6") | 600 mm (23.6") |
| EA5..750.. | 828 mm (32.6") | 861 mm (33.9") | 800 mm (31.5") | 750 mm (29.5") |
| EA5..900.. | 978 mm (38.5") | 1011 mm (39.8") | 950 mm (37.4") | 900 mm (35.4") |
| EA5..1050.. | 1128 mm (44.4") | 1161 mm (45.7") | 1100 mm (43.3") | 1050 mm (41.3") |
| EA5..1200.. | 1278 mm (50.3") | 1311 mm (51.6") | 1250 mm (49.2") | 1200 mm (47.2") |
| EA5..1500.. | 1578 mm (62.1") | 1611 mm (63.4") | 1550 mm (61.0") | 1500 mm (59.1") |
| EA5..1800.. | 1878 mm (73.9") | 1911 mm (75.2") | 1850 mm (72.8") | 1800 mm (70.9") |
| EA5..2100.. | 2178 mm (85.7") | 2211 mm (87.0") | 2150 mm (84.6") | 2100 mm (82.7") |
| EA5..2400.. | 2478 mm (97.6") | 2511 mm (98.9") | 2450 mm (96.4") | 2400 mm (94.5") |

3.8 Standard Bracket Dimensions

End Cap Brackets (model EZA-MBK-11*)

4 x R 19.4 mm (0.76")
 4 x 5.8 mm (0.23") wide slots
 Ø 21.5 mm (0.85")
 Ø 33 mm (1.30")
 4 x 45
 38.2 mm (1.50")
 50 mm (1.96")
 4.2 mm (0.17")
 63.2 mm (2.49")
 25 mm (0.98")

2 x 5 mm (0.20")
 2 x 7 mm (0.28")
 2 x R 5 mm (0.20")
 2 x 15 mm (0.59")
 20 mm (0.79")

*Dimensions are identical for model EZA-MBK-11N stainless steel brackets.

Center Bracket (model EZA-MBK-12)**

Ø 60 mm
 20 mm (0.79")
 20 mm (0.79")
 55 mm (2.17")
 20 mm (0.79")
 17.5 mm (0.69")
 50 mm (1.97")
 55.6 mm (2.19")
 4.2 mm (0.17")
 10 mm (0.39")
 9.5 mm (0.37")
 36 mm (1.42")
 15 mm (0.59")
 20.0 mm (0.79")
 Ø 8.3 mm (0.33")
 Ø 7 mm (0.28")

** Supplied with emitters and receivers over 1050 mm.

4 Installation and Alignment

4.1 Mounting the Emitter and Receiver

Compact EZ-ARRAY emitters and receivers are easy to handle during mounting. When mounted to the sensor end caps, the supplied mounting brackets allow $\pm 30^\circ$ rotation. An emitter may be separated from 400 mm to 4 m (16" to 13') from its receiver.

From a common point of reference, make measurements to locate the emitter and receiver in the same plane, with their midpoints and display ends directly opposite each other. (If sensors are mounted with their display ends at the top, see [Receiver Gray Wire](#) or refer to HW Interface table in [General Configuration](#) for directions on inverting the 3-digit display.) Mount the brackets to the emitter and receiver housings using the supplied M6 bolts and Keps nuts, or user-supplied hardware; see Figure 4-1.

Center mounting brackets must be used with longer sensors, if they are subject to shock or vibration. In such situations, the sensors are designed to be mounted with up to 900 mm unsupported distance (between brackets). Sensors 1050 mm and longer are supplied with a center bracket to be used as needed with the standard end-cap brackets.

1. Attach the center bracket to the mounting surface when mounting the end-cap brackets.
2. Attach the clamp to both slots of the housing, using the included M5 screws and T-nuts.
3. After the sensor is mounted to the end-cap brackets, attach the clamp to the center bracket using the supplied M5 screw.

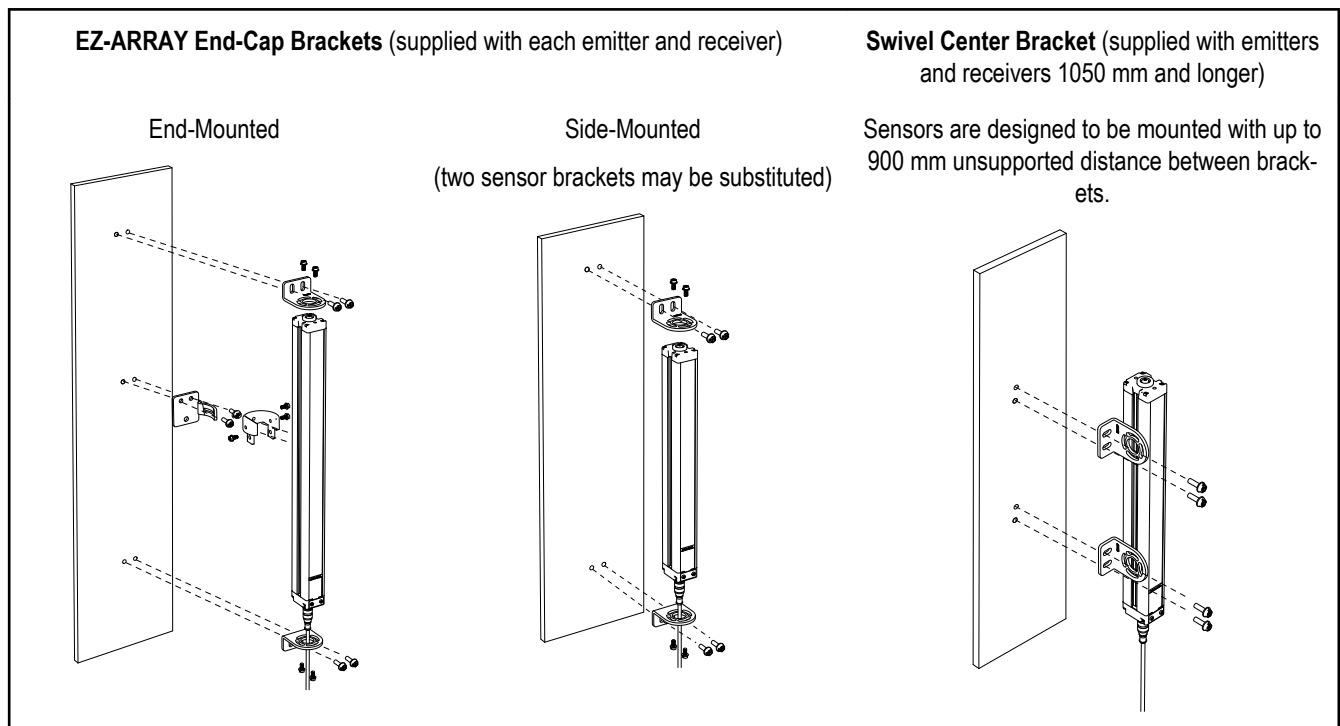

Figure 4-1. A-GAGE EZ-ARRAY emitter and receiver mounting hardware

4.2 Mechanical Alignment

Mount the emitter and receiver in their brackets and position the windows of the two units directly facing each other. Measure from one or more reference planes (e.g., the building floor) to the same point(s) on the emitter and receiver to verify their mechanical alignment. Use a carpenter's level, a plumb bob, or the optional LAT-1-SS Laser Alignment Tool, or check the diagonal distances between the sensors, to achieve mechanical alignment.

When alignment is difficult, a LAT-1-SS tool is useful to assist or confirm alignment by providing a visible red dot along the sensor's optical axis (see Figure 4-2). Snap the LAT-1 clip onto the sensor housing, turn on its laser emitter, and use a strip of retro-reflective tape at the opposite sensor to see the dot.

Also check "by eye" for line-of-sight alignment. Make any necessary final mechanical adjustments, and hand-tighten the bracket hardware. See [Optical Alignment](#) and [Alignment Blanking Button](#) for further alignment information.

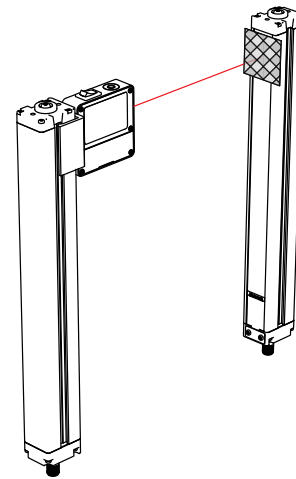
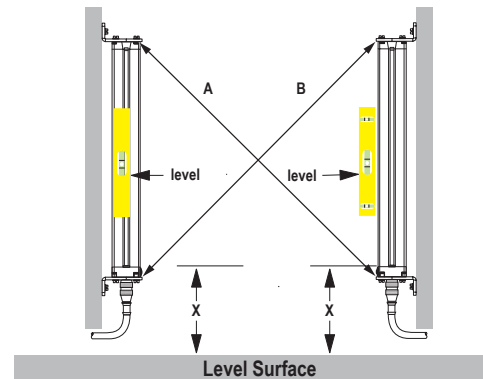
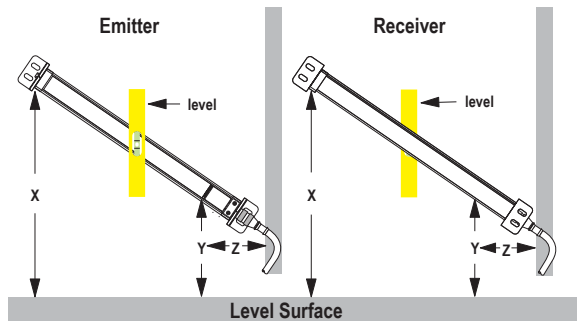
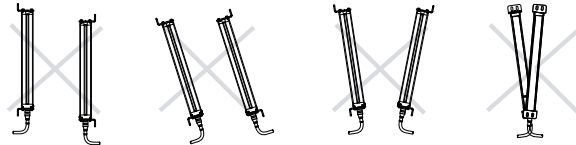

Figure 4-2. Optical alignment using the LAT-1-SS

Figure 4-3. Sensor mounting, mechanical alignment

Verify that:

- The emitter and receiver are directly opposite each other, and nothing is interrupting the beams.
- The sensing area is the same distance from a common reference plane for each sensor.
- The emitter and receiver are in the same plane and are **level/plumb and square to each other** (vertical, horizontal, or inclined at the same angle, and not tilted front-to-back or side-to-side).



Angled or Horizontal Installations - verify that:

- Distance X at the emitter and receiver are equal.
- Distance Y at the emitter and receiver are equal.
- Distance Z at the emitter and receiver are equal from parallel surfaces.
- Vertical face (i.e., the lens) is level/plumb.
- Sensing area is square. Check diagonal measurements if possible; see Vertical Installations at right.

Vertical Installations - verify that:

- Distance X at emitter and receiver are equal.
- Both sensors are level/plumb (check both the side and face).
- Sensing area is square. Verify diagonal measurements if possible (Diagonal A = Diagonal B).

4.3 Hookups

Refer to Figures 4-4 and 4-5 for the appropriate hookup information.

Inputs

Receiver gray wire: The receiver has an input that can be used as a gate input or for remote teach. To initiate remote teach, alignment, and gating functions, tie the wire through a switch to sensor common. See [Receiver Gray \(Remote Teach\) Wire](#) for more information.

Outputs

Refer to Figures 4-4 and 4-5 for standard hookup information and [Specifications](#) for further electrical requirements.

Analog white and yellow wires: The receiver has two analog outputs. Both outputs are voltage analog outputs. The white wire is referenced as analog output 1; the yellow wire is referenced as analog output 2. The voltage analog outputs will source current through an external load to sensor common.

Discrete Outputs: The receiver has two discrete outputs; the green wire is referenced as discrete output 1, and the red wire is referenced as discrete output 2. Discrete output 1 is a push-pull output. Discrete output 2 is PNP, unless the polarity is altered via the communication interface. Refer to [Specifications](#) for further electrical requirements.

Sync (Pink) Wire

The emitter and receiver are electrically synchronized via the pink wire. The emitter and receiver pink wires must only be electrically connected together.

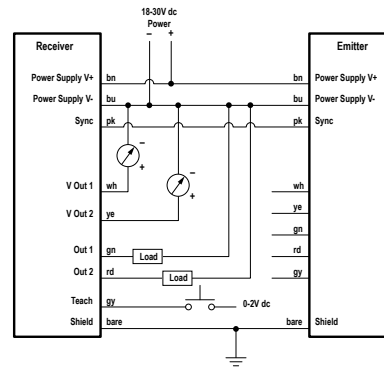

Figure 4-4. Hookup for outputs configured as PNP (without IO-Link Master)

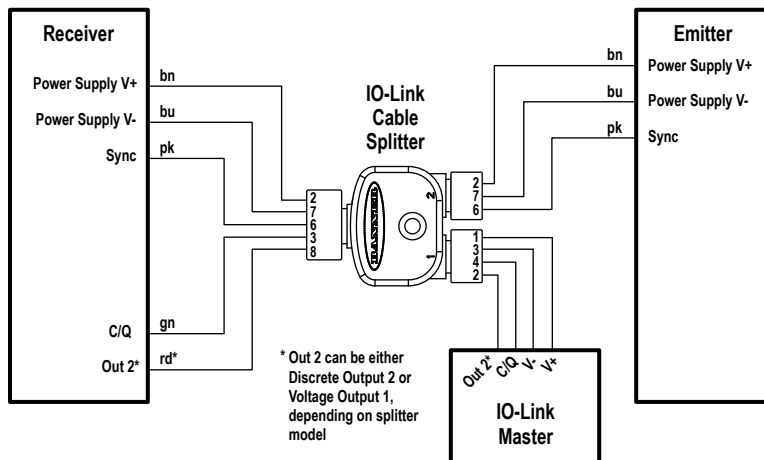

Figure 4-5. Hookup with IO-Link Master

4.4 Optical Alignment

After the electrical connections are made, power up the emitter and receiver. Verify that input power is present to both emitter and receiver; the emitter Status indicator and the receiver Status LED should be ON green. If the receiver Status LED is on red (and a "c" appears on the 3-digit display), refer to [Troubleshooting and Error Codes](#).



NOTE: At power-up, all Zone indicators are tested (flash red), then the number of blocked beams is displayed.

Observe the receiver indicators (see table below).

Optimize Alignment and Maximize Excess Gain

Verify that the emitter and receiver are pointed squarely at each other. A straightedge (e.g., a level) can help determine the direction the sensor is facing (see Figure 4-7).

Slightly loosen the sensor mounting screws and rotate one sensor to the left and right, noting the positions where the receiver Zone indicators turn from green to red; repeat with the other sensor. Center each sensor between the noted positions and tighten the end cap mounting screws, making sure to maintain the positioning. The sensor windows should directly face each other.

Once optimum optical alignment is verified, proceed to configuration, via the remote teach wire, the receiver interface, or the IO-Link interface ([Receiver Gray Wire](#), [Alignment Blanking Button](#), or refer to the [Appendix: IO Link Alignment Blanking Routine](#)) and complete the electronic alignment. This further alignment step adjusts the emitted light level of each beam for the application, to maximize sensing performance.

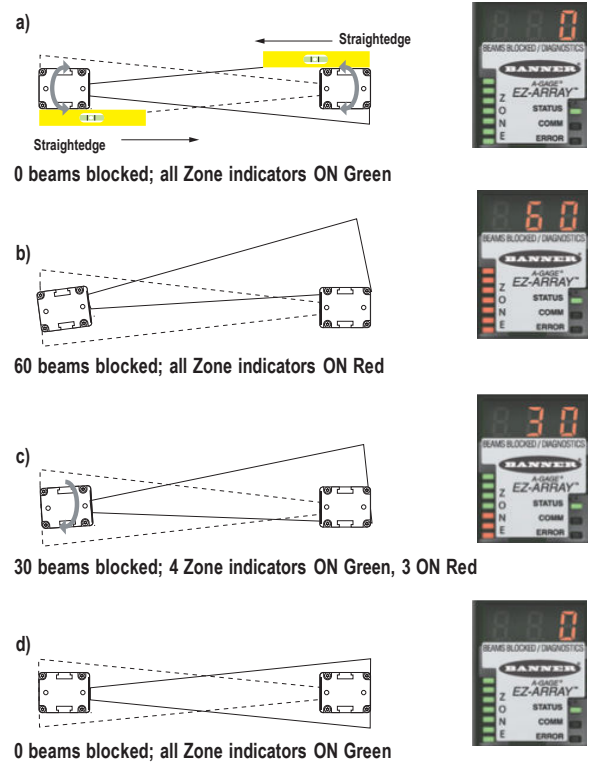

Figure 4-7. Optimizing optical alignment; 300 mm model shown

Figure 4-8. Receiver Interface Indicators during Alignment

| | All Beams Either Clear or Blanked | Some Beams Blocked or Mis-Aligned | Out of Alignment |
|----------------------------------|-----------------------------------|---|--|
| Zone Indicators | All ON Green | Some ON Red (zones with blocked beams) Some ON Green (zones with all clear beams) | All ON Red (Some beams blocked in each zone) |
| Receiver Status Indicator | ON Green | ON Green | ON Green |
| 3-Digit Display | 0 (Number of blocked beams) | Number of blocked beams | Total number of beams in the array |

5 Receiver User Interface

The receiver user interface comprises the six-position DIP switch, two push buttons, 3-digit display, and other indicators present on the receiver (see [Status Indicators](#) for more complete status indicator information). The receiver interface enables configuration of standardized combinations of the EZ-ARRAY sensing options (output configuration, scanning methods and modes); for more advanced setup, refer to to [IO-Link Interface](#).

5.1 Configuration DIP Switch

The DIP switch can be used to configure the sensor. Access the switch by removing the screw-on security plate and lifting the clear hinged access cover. The access cover may be removed entirely (pull straight out to remove, press back in to replace) for easier access during configuration.

Some of the switches are assigned their own functions, others work together in combination (see table). Switches S1 and S2 in combination select one of four scanning modes. Switches S3 and S4 in combination select one of four measurement mode pairs (one for each analog output). Switch S5 defines the analog slope setting for both analog outputs and S6 defines whether discrete output 2 is complementary to discrete 1, or functions as an alarm (when configuration is accomplished via DIP switch, discrete output 1 and analog output 1 follow the same measurement mode).



Figure 5-1. Receiver user interface. NOTE: All DIP switch positions are shown in the ON condition

Figure 5-2. EZ-ARRAY Receiver User Interface DIP Switch Settings

| Switch Settings* | | Result | |
|--|-----------|--|-----------------|
| S1 | S2 | Scan Mode | |
| <u>ON</u> | <u>ON</u> | Straight Scan | |
| ON | OFF | Double-Edge, Step 1 | |
| OFF | ON | Double-Edge, Step 4 | |
| OFF | OFF | Single-Edge | |
| S3 | S4 | Analog 1 (Value reads on 3-digit display) | Analog 2 |
| <u>ON</u> | <u>ON</u> | TBB | FBB |
| ON | OFF | LBB | MBB |
| OFF | ON | OD | ID |
| OFF | OFF | CBB | CFBB |
| S5 ON | | Positive Analog Slope | |
| S5 OFF | | Negative Analog Slope | |
| S6 ON | | Discrete 2 Complementary | |
| S6 OFF | | Discrete 2 Alarm | |
| * <u>Underlined</u> setting are factory defaults | | | |

5.1.1 Scanning Modes (S1 and S2)

Straight Scan (S1 ON, S2 ON)

Straight Scan is the most versatile scanning mode and can be used without the exceptions noted in the other scanning modes. Use this scanning mode when using the low-contrast sensitivity setting to measure semi-transparent materials.

Double-Edge Step 1 (S1 ON, S2 OFF)

Double-Edge Step 1 can be used when three or fewer opaque objects are presented to the light curtain at one time. The advantage of this mode is improved sensor edge resolution (2.5 mm). The minimum object detection size is 10 mm.

Double-Edge Step 4 (S1 OFF, S2 ON)

Double-Edge Step 4 can be used when three or fewer opaque objects are presented to the light curtain and the minimum size object to be detected is 30 mm. This scanning mode ignores objects smaller than 30 mm. Like Double-Edge Step 1, the sensor edge resolution is 2.5 mm. See Figure 2-8 for sensor scan times.

Single-Edge Scan (S1 OFF, S2 OFF)

Single-Edge Scan can be used when a single opaque object is presented to the light curtain at one time. The object must block the "bottom" channel (the channel closest to the receiver display). Like the double-edge scans, the sensor edge resolution is 2.5 mm. The minimum object detection size is 10 mm. See Figure 2-8 for sensor scan times. Because single-edge scan is capable only of measuring the height of an opaque object that blocks the bottom channel and all channels up to the height of the object, the pertinent measurement modes are LBB (last beam blocked) or TBB (total beams blocked). When single-edge scan is selected, the selected measurement mode will be applied to both analog outputs. Selection of OD/ID with single-edge scan will result in an error code.

5.1.2 Measurement Modes (S3 and S4)

The measurement modes, determined by switches S3 and S4 in combination, define what information is calculated by the sensor and sent via the analog outputs. See [Measurement Mode Selection](#) for measurement mode definitions. Discrete output 1 and analog output 1 will follow the same measurement mode. (If single-edge scan is selected, select measurement mode LBB or TBB.)

During normal operation, the 3-digit diagnostic display reads out the numerical value of the specified measuring mode for analog output 1.

5.1.3 Analog Slope (S5)

Switch S5 defines the analog output slope. As the measurement mode values increase, the analog output voltage can either increase (positive slope, S5 ON) or decrease (negative slope, S5 OFF). Switch S5 applies the same slope to both analog outputs.

5.1.4 Complementary/Alarm (S6)

Switch S6 defines the operation of discrete output 2. When the receiver user interface is used, discrete output 1 is active when an object is detected by the sensor (normally open operation). In complementary mode (S6 ON), output 2 will always be in the opposite state of output 1. In alarm mode (S6 OFF), discrete output 2 will be active when the sensor detects a system fault. System faults include a failed emitter, mis-wiring of the emitter/receiver communication wire (the pink wire), and low excess gain (if the sensor is configured for high-contrast sensitivity).

5.2 Alignment/Blanking Button (Electronic Alignment)

The Alignment/Blanking push button is used both to maximize the alignment and to access the blanking feature. The electronic alignment routine adjusts the emitted light level to maximize sensor performance. Perform the procedure at installation and again when the emitter and/or receiver is moved. For IO-Link interface alignment instructions, see [Alignment Blanking Routine](#).

Blanking is used to maintain sensing accuracy in applications where a fixed object (for instance a permanently mounted bracket) will block one or more beams. The sensor will ignore the blanked channels when calculating outputs from the selected measurement modes.

5.2.1 Electronic Alignment and Blanking - Receiver Interface

To initiate the electronic alignment procedure, use a small screwdriver to press the Alignment/Blanking button for two or more seconds. The left-hand digit of the 3-digit display will read "A" (representing alignment); the right two digits will show the number of beams blocked. The receiver is learning the clear condition. Rotate the sensors as required (but do not change the distance between them). When the receiver's 3-digit display shows 0 beams blocked, the sensors are adequately aligned.

Tighten the sensor mounts, then press the Alignment/Blanking button again for two seconds to exit alignment mode. If all sensor light channels are clear, the EZ-ARRAY stores each channel's signal strength in non-volatile memory and reads "- - -" on the 3-digit display. Re-alignment is not required again, unless the emitter or receiver is moved.

If any beams are blocked by objects other than the sensing target to be measured during run mode, those beams can be blanked in alignment mode for more accurate measurement. The blocked beams must be either blanked or cleared during alignment mode for alignment to proceed (see below). While the "A" is visible on the receiver display, momentarily (about 0.5 seconds max.) press the Alignment/Blanking button again. The "A" will change to "n" to indicate the sensor is ready to "learn" the blanking pattern; momentarily press the button again to exit the blanking routine. The sensor blanks the blocked beams and the display changes to "A."; the period following the lefthand digit signifies blanking is active. Press the Alignment/Blanking button for two seconds to exit alignment mode. The EZ-ARRAY stores each channel's signal strength in non-volatile memory and reads "- . -" on the 3-digit display to denote blanking is in use.

5.2.2 Flashing "000" on the 3-Digit Display

When returning to run mode, the receiver determines whether any unblanked beam channels are obstructed. If any channels are obstructed, the new alignment settings are not saved; the receiver flashes zeroes on the display three times and sensing will continue, using the previously set alignment settings. If this occurs, either clear the blocked beams and repeat the alignment routine or repeat the alignment routine and blank the blocked beams.

5.3 Gain (Sensitivity Adjust) Button

To change the sensitivity (Gain setting), press and hold the button for two seconds. The left-hand digit of the 3-digit display will read "L"; the right-hand digit will read "1" (high excess-gain) or "2" (low-contrast). The sensitivity level can then be toggled between the values 1 and 2. When the desired sensitivity level is displayed, hold the Gain push button for 2 seconds and the sensor will return to run mode.

5.4 Inverting the 3-Digit Display

For instances where the sensors must be mounted in an inverted position, the 3-digit display can be can be inverted for readability. See [Receiver Gray Wire](#). The 3-digit display can then be switched back to "normal" by repeating the procedure.



NOTE: The periods on the three seven-segment indicators do not move when the display is inverted.

5.5 Troubleshooting and Error Codes

If the receiver Status LED is red and the 3-digit display reads "c" followed by a number from 1 to 10, a corrective action is needed (see table below).

5.5.1 "Dirty" Channel Indicator

If the Status LED is red, but no "c" is visible on the 3-digit display (the scan measurement mode result is displayed), the sensor alignment is marginal. Clean the sensor windows and perform the alignment procedure as necessary.

For all corrective actions, first verify proper supply voltages and wiring connectivity. Disconnect and re-connect the sensor cable connectors to verify proper connector installation.

Figure 5-3. Error Codes

| Error Code | Problem | Corrective Action |
|------------|---|---|
| 1 | Receiver EEPROM Hard Failure | This problem is caused by a receiver failure that cannot be corrected by the user. Replace the receiver. |
| 2 | Receiver Alignment/Blanking Configuration Error | Remove and re-apply sensor supply voltage. If the error code 2 is removed, electrically re-align the sensor (<i>Alignment/Blanking Button</i>). If the error code persists, contact Banner for further problem-solving techniques. |
| 3 | Reserved for Factory | Replace the receiver. |
| 4 | Emitter or Wiring Problem | <ol style="list-style-type: none"> 1. Verify that emitter and receiver wiring is correct (see Figures 4-4 and 4-5). 2. Check the status of the emitter Status LED. Emitter LED OFF: Check the voltage across the emitter brown and blue wires. If the voltage across the emitter brown and blue wire is OK, then replace the emitter. Emitter Status LED flashing (approx. every 2 seconds): Verify that the emitter/receiver synch (pink) wires are correctly installed. 3. Verify that the Synch wires are correctly installed. Check the synch wire dc voltage. If the voltage is below 1 volt or above 3 volts, then again check the synch wire for possible mis-wiring. Unplug first the receiver and then the emitter to determine the problem source. |
| 5 | Emitter Channel Error | The emitter has identified a nonfunctional optical channel. Temporary fix: Blank the channel (Section <i>Alignment/Blanking Button</i>) to ignore the problem. Permanent fix: Replace the emitter. |
| 6 | Reserved for Factory | Replace the receiver. |
| 7 | Reserved for Factory | Replace the emitter. |
| 8 | Reserved for Factory | Replace the receiver. |
| 9 | Reserved for Factory | Replace the receiver. |
| 10 | Incompatible Scan and Measurement Mode | Some measurement modes are incompatible with some scanning modes. Single-Edge Scan; do not use the following measurement modes: OD, ID, FBM, LBM, TBM, CBM, Nap Detection Double-Edge Scan; do not use the following measurement modes: FBM, LBM, TBM, CBM, Nap Detection |

6 IO-Link Interface

6.1 Overview

For the latest IO-Link protocol and specifications, please visit the web site at <http://www.io-link.com>

IO-Link is a point-to-point communication link between master and slave. It can be used to automatically parameterize sensors and transmit process data.

6.2 IO-Link Profile and Models

Figure 6-1. IO-Link Profile

| | |
|---|--|
| IO-Link Version | 1.0 |
| COM-Mode | COM2 (38,400 bps) |
| Process Data Width | 16-Bit |
| Process Data Structure | Input Data: Bit 0-12: Measurement 1 Value, Bit 13-15: Reserved |
| SIO-Mode Support | Yes |
| Memory Request for Data Management | 180 Bytes |
| Sub-Index Access | Not Supported |

Figure 6-2. Device IDs and Minimum Cycle Times

| Model | Device ID | Min. Cycle Time (ms) |
|--------------|------------------|-----------------------------|
| EA5R150XKQ | 65536 | 11.6 |
| EA5R300XKQ | 65537 | 19.2 |
| EA5R450XKQ | 65538 | 26.4 |
| EA5R600XKQ | 65539 | 35.2 |
| EA5R750XKQ | 65540 | 43.2 |
| EA5R900XKQ | 65541 | 49.6 |
| EA5R1050XKQ | 65542 | 57.6 |
| EA5R1200XKQ | 65543 | 64.0 |
| EA5R1500XKQ | 65545 | 80.0 |
| EA5R1800XKQ | 65546 | 94.4 |
| EA5R2100XKQ | 65547 | 108.8 |
| EA5R2400XKQ | 65548 | 123.2 |

6.3 Hardware Interface

IO-Link is designed around IEC 61131-9 Single-drop digital communication interface for sensors and actuators (SDCI). Figure 6-3 shows the SDCI connection for 3-wire connection devices. Power, ground, communication, and/or switching signal are required, pin 2 is an optional I/O. The EZ-ARRAY provides the SDCI connection with an IO-Link cable splitter accessory. The EZ-Array is a Port Class A device.

Figure 6-3. SDCI Connection

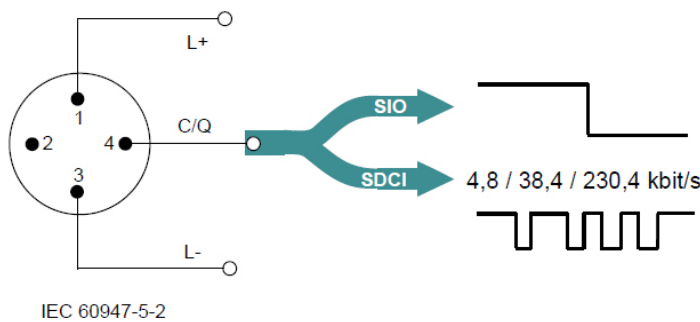

| Pin | Signal | Definition | Standard |
|-----|--------|---------------------------------|-------------|
| 1 | L+ | 24 V | IEC 61131-2 |
| 2 | I/Q | Not connected, DI, or DO | IEC 61131-2 |
| 3 | L- | 0 V | IEC 61131-2 |
| 4 | Q | "Switching signal" DI, DO (SIO) | IEC 61131-2 |
| | C | "Coded switching" (SDCI) | IEC 61131-9 |

6.3.1 Electrical Interface

Figures 6-4 and 6-6 show the pinout of the EZ-ARRAY IO-Link cable splitters.

Figure 6-4. EZ-ARRAY IO-Link Cable Splitter Pinouts

| IO-Link Splitter Connector #1 | CSB-M1240M1280 (Dual Discrete) | | | | CSB-M1250M1280 (Analog) | | | |
|-------------------------------|--------------------------------|--------------|--------|----------------------------|--------------------------|--------------|--------|----------------------------|
| | EZ-ARRAY 8-Pin Connector | 8-Wire Cable | Signal | Definition | EZ-ARRAY 8-Pin Connector | 8-Wire Cable | Signal | Definition |
| 1 | 2 | Brown | L+ | 18-30 VDC | 2 | Brown | L+ | 18-30 VDC |
| 2 | 8 | Red | Q | Switching Signal D02 | 1 | White | AO | V Out 1 (0-10V) |
| 3 | 7 | Blue | L- | 0 VDC | 7 | Blue | L- | 0 VDC |
| 4 | 3 | Green | Q | Switching Signal DO1 (SIO) | 3 | Green | Q | Switching Signal DO1 (SIO) |
| | | | C | IO-Link (SDCI) | | | C | IO-Link (SDCI) |
| 5 | NC | NC | NC | No Connection | NC | NC | NC | No Connection |

Figure 6-5. IO-Link Splitter



Figure 6-6.

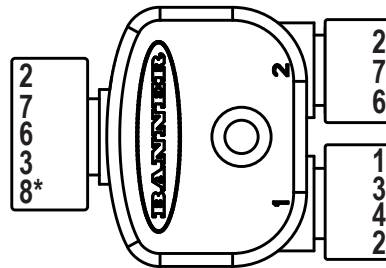

*CSB-M1240M1280 is shown, for CSB-M1250M1280 pin 1 is connected



NOTE: If an additional cable between the receiver and splitter is required, its length must be less than a meter.

6.3.2 IO-Link Master

A list of IO-Link Master manufacturers can be found under the "About Us" at www.io-link.com.

6.4 IODD (IO-Link Device Description)

An IODD file is a file that formally describes a device using XML notation. The IODD provides all the necessary properties to establish communication and configuration. The EZ-ARRAY IO-Link IODD package consists of an IODD file, and three image files:

- Banner_Engineering-<Device Name>-<Date>-IODD1.0.1.xml
- Banner_Engineering-logo.png
- Banner_Engineering-EA5RXK-icon.png
- Banner_Engineering-EA5RXK-pic.png

This IO-Link IODD package is contained on the supplied IO-Link Device Description Resource CD (P/N 18491). For the latest IODD packages, please refer to the Banner website at <http://www.bannerengineering.com/IO-Link>.

6.5 Configuration Data

IO-Link models of the EZ-ARRAY use the Service Parameter Data Unit (SPDU) channel for providing read-write access to configuration data.

6.5.1 Scan Configuration

The *Scan Configuration* contains the settings for the scan type and receiver's remote teach wire (gray wire) function.

Table A-1. Scan Configuration

| SPDU | | Byte Position | Member Name |
|-------|-----------|---------------|-------------------|
| Index | Sub-Index | | |
| 80 | 1 | 0 | Scan Type |
| 80 | 2 | 1 | Remote Teach/Gate |

Table A-2. Scan Type

| Value | Type | Description |
|-------|-----------------------|---|
| 1 | Straight | Straight Scanning |
| 2 | Single Edge | Scanning for Single Edge |
| 3 | Double Edge - Step 1 | Scanning for Edges of up to 3 objects (fires every channel) |
| 4 | Double Edge - Step 2 | Scanning for Edges of up to 3 objects (fires channels 1, 3, 5, ...) |
| 5 | Double Edge - Step 4 | Scanning for Edges of up to 3 objects (fires channels 1, 5, 9, ...) |
| 6 | Double Edge - Step 8 | Scanning for Edges of up to 3 objects (fires channels 1, 9, 17, ...) |
| 7 | Double Edge - Step 16 | Scanning for Edges of up to 3 objects (fires channels 1, 17, 33, ...) |
| 8 | Double Edge - Step 32 | Scanning for Edges of up to 3 objects (fires channels 1, 33, 65, ...) |
| 10 | Carpet Nap | Scanning for Carpet Nap Detection Applications |

Table A-3. Remote Teach/Gate

| Value | Function | Description |
|-------|-----------------------|--|
| 0 | Disabled | Disabled |
| 1 | Remote Teach | Enabled with All Functionality |
| 2 | Alignment/Sensitivity | Only Alignment, Blanking, and Sensitivity Adjustments can be performed |
| 3 | Gate - Active High | Setting the gray wire in the high state enables scanning |
| 4 | Gate - Active Low | Setting the gray wire in the low state enables scanning |
| 5 | Gate - Rising Edge | A single scan will occur after the gray wire goes from a low-to-high state |
| 6 | Gate - Falling Edge | A single scan will occur after the gray wire goes from a high-to-low state |

6.5.2 Blanking Configuration

The *Blanking Configuration* contains the blanking bit-mask for the EZ-ARRAY's channels. Each sub-index represents 16 channels.

Table A-4. Blanking Configuration

| SPDU | | Byte Position | Member Name |
|-------|-----------|---------------|------------------|
| Index | Sub-Index | | |
| 81 | 1 | 0 | Blanking 1-8 |
| 81 | 1 | 1 | Blanking 9-16 |
| 81 | ... | ... | ... |
| 81 | 30 | 58 | Blanking 465-472 |
| 81 | 30 | 59 | Blanking 473-480 |

Table A-5. Blanking Bit-Mask

| Value | Status | Description |
|-------|-------------|---|
| 0 | Non-Blanked | The channel will be used during scanning |
| 1 | Blanked | The channel will be skipped during scanning |

6.5.3 General Configuration

The *General Configuration* contains the general settings for the EZ-ARRAY.

Table A-7. General Configuration

| SPDU | | Byte Position | Member Name |
|-------|----------------|---------------|------------------------------------|
| Index | Sub-Index | | |
| 86 | 1 | 0 | Emitter Power |
| 86 | 2 | 1 | Gain Method |
| 86 | 3 | 2 | Low Contrast Sensitivity |
| 86 | See table A-11 | 3 | HW Interface Flags |
| 86 | 9 | 4 | Measurement 1 (Input Process Data) |
| 86 | 10 | 5 | Measurement 2 |
| 86 | 12 | 8-9 | Number of Dirty Channels |
| 86 | 13 | 10-13 | Time of Service |

Table A-8. Emitter Power

| Value | Function | Description |
|-------|----------|----------------------------|
| 1 | Level 1 | Power Setting 1 (Lowest) |
| 2 | Level 2 | Power Setting 2 |
| 3 | Level 3 | Power Setting 3 |
| 4 | Level 4 | Power Setting 4 |
| 5 | Level 5 | Power Setting 5 |
| 6 | Level 6 | Power Setting 6 |
| 7 | Level 7 | Power Setting 7 |
| 8 | Level 8 | Power Setting 8 |
| 9 | Level 9 | Power Setting 9 |
| 10 | Level 10 | Power Setting 10 |
| 11 | Level 11 | Power Setting 11 (Highest) |

Table A-9. Gain Method

| Value | Status | Description |
|-------|------------------|--|
| 1 | High-Excess Gain | Fixed thresholds for maximum excess gain |
| 2 | Low Contrast | Adjustable percentage based thresholds (only in Straight Scan) |

Table A-10. Low Contrast Sensitivity

| Value | Function | Description |
|-------|----------|---|
| 0 | 10% | Blocked threshold is set 10% below aligned signal |
| 1 | 15% | Blocked threshold is set 15% below aligned signal |
| 2 | 20% | Blocked threshold is set 20% below aligned signal |
| 3 | 25% | Blocked threshold is set 25% below aligned signal |
| 4 | 30% | Blocked threshold is set 30% below aligned signal |
| 5 | 35% | Blocked threshold is set 35% below aligned signal |
| 6 | 40% | Blocked threshold is set 40% below aligned signal |
| 7 | 45% | Blocked threshold is set 45% below aligned signal |
| 8 | 50% | Blocked threshold is set 50% below aligned signal |

Table A-11. HW Interface Flags

| SPDU Sub-Index | Bit Position | Flag | Description |
|----------------|--------------|---------------------|--------------------------------------|
| 4 | 0 | Display Orientation | 0 = Normal, 1 = Inverted |
| 5 | 1 | Configuration Type | 0 = DIP Switch, 1 = Advanced Control |
| 6 | 2 | Sensitivity Button | 0 = Enabled, 1 = Disabled |
| 7 | 3 | Align/Blank Button | 0 = Enabled, 1 = Disabled |

Table A-12. Measurement 1 and Measurement 2

| Measurement 1 & Measurement 2 | | |
|-------------------------------|----------|--------------------------|
| Value | Function | Description |
| 0 | Disabled | Disabled |
| 1 | FBB | First Beam Blocked |
| 2 | LBB | Last Beam Blocked |
| 3 | TBB | Total Beams Blocked |
| 4 | TRN | Transitions |
| 5 | CBB | Contiguous Beams Blocked |
| 6 | FBM | First Beam Made |
| 7 | LBM | Last Beam Made |
| 8 | TBM | Total Beams Made |

| Measurement 1 & Measurement 2 | | |
|-------------------------------|-------------|-------------------------------|
| Value | Function | Description |
| 9 | CBM | Contiguous Beams Made |
| 10 | MBB | Middle Beam Blocked |
| 11 | OD | Outer Diameter |
| 12 | ID | Inner Diameter |
| 13 | CFBB | Contiguous First Beam Blocked |
| 14 | CLBB | Contiguous Last Beam Blocked |
| 15 | O1 FBB | Object 1 First Beam Blocked |
| 16 | O1 LBB | Object 1 Last Beam Blocked |
| 17 | O2 FBB | Object 2 First Beam Blocked |
| 18 | O2 LBB | Object 2 Last Beam Blocked |
| 19 | O3 FBB | Object 3 First Beam Blocked |
| 20 | O3 LBB | Object 3 Last Beam Blocked |
| 21 | CARPET NAP | Carpet Nap |
| 24 | CARPET EDGE | Carpet Edge |

Table A-13. Number of Dirty Channels

| Range | Description |
|-------|--|
| 1-360 | Number of channels that need to be dirty before indicator is lit (150 to 1800 mm Length Models) |
| 1-480 | Number of channels that need to be dirty before indicator is lit (2100 to 2400 mm Length Models) |

Table A-14. Time of Service

| Range | Description |
|--------|--|
| 2^32-1 | Number of hours EZ-ARRAY has been in operation |

6.5.4 Analog Output 1 Configuration

The *Analog Output 1 Configuration* contains the settings for the first analog output.

Table A-21. Analog Output 1 Configuration

| SPDU | | Byte Position | Member Name |
|-------|----------------|---------------|--------------|
| Index | Sub-Index | | |
| 82 | See table A-22 | 0 | Config Flags |
| 82 | 9 | 2 | Filter Speed |
| 82 | 11 | 4-5 | NULL Output |
| 82 | 12 | 6-7 | SPAN Output |

Table A-22. Config Flags (Analog Output 1 & 2)

| SPDU Sub-Index | Bit Position | Flag | Description |
|----------------|--------------|-----------------------|---------------------------------------|
| 1 | 0 | Slope | 0 = Negative, 1 = Positive |
| 2 | 1 | Measurement | 0 = Measurement 2, 1 = Measurement 1 |
| 3 | 2-3 | ZERO Value | 0 = Hold, 1 = Minimum, 2 = Maximum |
| 4 | 4 | Peak Detect | 0 = Disabled, 1 = Enabled |
| 5 | 5 | Peak Detect Direction | 0 = Maximum, 1 = Minimum |
| 6 | 6 | Status | 0 = Disabled, 1 = Enabled |
| 7 | 7 | Peak Detect Reset | 0 = Auto, 1 = External Communications |

Table A-23. Filter Speed (Analog Output 1 & 2)

| Value | Filter Speed | Description |
|-------|--------------|--|
| 0 | Fast | No filtering |
| 1 | Medium | Filter step response is 6 scans for 98% of signal |
| 3 | Slow | Filter step response is 24 scans for 98% of signal |

Table A-24. NULL Output (Analog Output 1 & 2)

| Range | Description |
|--------|--|
| 0-4095 | Minimum DAC value of Analog Output (MUST be < SPAN Output) |

Table A-25. SPAN Output (Analog Output 1 & 2)

| Range | Description |
|--------|--|
| 0-4095 | Maximum DAC value of Analog Output (MUST be > NULL Output) |

6.5.5 Analog Output 2 Configuration

The *Analog Output 2 Configuration* contains the settings for the second analog output.

Table A-26. Analog Output 2 Configuration

| SPDU | | Byte Position | Member Name |
|-------|----------------|---------------|--------------|
| Index | Sub-Index | | |
| 83 | See Table A-22 | 0 | Config Flags |
| 83 | 9 | 2 | Filter Speed |
| 83 | 11 | 4-5 | NULL Output |
| 83 | 12 | 6-7 | SPAN Output |

6.5.6 Discrete Output 1 Configuration

The *Discrete Output 1 Configuration* contains the settings for the first discrete output.

Table A-27. Discrete Output 1 Configuration

| SPDU | | Byte Position | Member Name |
|-------|----------------|---------------|-----------------|
| Index | Sub-Index | | |
| 84 | See Table A-28 | 0 | Config Flags |
| 84 | 7 | 2-3 | Scan Response |
| 84 | 8 | 4-5 | Hysteresis LOW |
| 84 | 9 | 6-7 | Hysteresis HIGH |
| 84 | 10 | 8-9 | Threshold LOW |
| 84 | 11 | 10-11 | Threshold HIGH |

Table A-28. Config Flags (Discrete Output 1 & 2)

| SPDU Sub-Index | Bit Position | Flag | Description |
|----------------|--------------|-----------------------|---|
| 1 | 0 | Status | 0 = Disabled, 1 = Enabled |
| 2 | 1 | Type | 0 = Measurement, 1 = Alarm/Health (Discrete Output 1 can ONLY be of type Measurement) |
| 3 | 2 | Polarity ¹ | 0 = PNP, 1 = NPN |
| 4 | 3 | Mode ² | 0 = Normally Closed (Health), 1 = Normally Open (Alarm) |
| 5 | 4 | Measurement | 0 = Measurement 2, 1 = Measurement 1 |

¹IO-Link Model: Discrete Output 2 ONLY, Discrete Output 1 is PUSH-PULL

²For Type = Alarm/Health, Mode setting corresponds to 0=Health, 1=Alarm

Table A-29. Scan Response (Discrete Output 1 & 2)

| Range | Description |
|-------|--|
| 1-250 | Number of consecutive measurements before changing state |

Table A-30. Hysteresis LOW (Discrete Output 1 & 2)

| Range | Description |
|-------|--|
| 0-359 | Lower hysteresis threshold for discrete output (MUST be < Threshold LOW) (150 to 1800 mm Length Models) |
| 0-479 | Lower hysteresis threshold for discrete output (MUST be < Threshold LOW) (2100 to 2400 mm Length Models) |

Table A-31. Hysteresis HIGH (Discrete Output 1 & 2)

| Range | Description |
|-------|---|
| 2-361 | Upper hysteresis threshold for discrete output (MUST be > Threshold HIGH) (150 to 1800 mm Length Models) |
| 2-481 | Upper hysteresis threshold for discrete output (MUST be > Threshold HIGH) (2100 to 2400 mm Length Models) |

Table A-32. Threshold LOW (Discrete Output 1 & 2)

| Range | Description |
|-------|---|
| 1-360 | Lower threshold for discrete output (MUST be <= Threshold HIGH) (150 to 1800 mm Length Models) |
| 1-480 | Lower threshold for discrete output (MUST be <= Threshold HIGH) (2100 to 2400 mm Length Models) |

Table A-33. Threshold HIGH (Discrete Output 1 & 2)

| Range | Description |
|-------|--|
| 1-360 | Upper threshold for discrete output (MUST be >= Threshold LOW) (150 to 1800 mm Length Models) |
| 1-480 | Upper threshold for discrete output (MUST be >= Threshold LOW) (2100 to 2400 mm Length Models) |

6.5.7 Discrete Output 2 Configuration

The *Discrete Output 2 Configuration* contains the settings for the second discrete output.

Table A-34. Discrete Output 2 Configuration

| SPDU | | Byte Position | Member Name |
|-------|----------------|---------------|--------------------|
| Index | Sub-Index | | |
| 85 | See Table A-28 | 0 | Configuration |
| 85 | 7 | 2-3 | Demodulation Count |
| 85 | 8 | 4-5 | Hysteresis LOW |
| 85 | 9 | 6-7 | Hysteresis HIGH |
| 85 | 10 | 8-9 | Threshold LOW |
| 85 | 11 | 10-11 | Threshold HIGH |

6.6 System Status and Measurement Data

IO-Link models of the EZ-ARRAY use the SPDU channel to provide access to system status measurement data and the Alignment/Blanking routine.

6.6.1 Active Measurements

The *Active Measurements* section contains the current values of the two measurements that were configured in the *General Configuration*.

Table B-1. Active Measurements

| SPDU | | Byte Position | Member Name |
|-------|-----------|---------------|---------------|
| Index | Sub-Index | | |
| 64 | 1 | 0-1 | Measurement 1 |
| 64 | 2 | 2-3 | Measurement 2 |

Table B-2. Measurement 1 and Measurement 2

| Range | Description |
|--------|---|
| 0-1920 | Measurements are represented in 4x channel resolution |

6.6.2 ALL Measurements

The *ALL Measurements* section contains the current values of all the available measurements.

Table B-3. ALL Measurements

| SPDU | | Byte Position | Member Name |
|-------|-----------|---------------|-------------|
| Index | Sub-Index | | |
| 67 | 1 | 0-1 | FBB |
| 67 | 2 | 2-3 | LBB |
| 67 | 3 | 4-5 | TBB |
| 67 | 4 | 6-7 | TRN |
| 67 | 5 | 8-9 | CBB |
| 67 | 6 | 10-11 | FBM |
| 67 | 7 | 12-13 | LBM |
| 67 | 8 | 14-15 | TBM |
| 67 | 9 | 16-17 | CBM |
| 67 | 10 | 18-19 | MBB |
| 67 | 11 | 20-21 | OD |
| 67 | 12 | 22-23 | ID |
| 67 | 13 | 24-25 | CFBB |
| 67 | 14 | 26-27 | CLBB |
| 67 | 15 | 28-29 | O1 FBB |
| 67 | 16 | 30-31 | O1 LBB |
| 67 | 17 | 32-33 | O2 FBB |
| 67 | 18 | 34-35 | O2 LBB |
| 67 | 19 | 36-37 | O3 FBB |
| 67 | 20 | 38-39 | O3 LBB |
| 67 | 21 | 40-41 | CARPET NAP |
| 67 | 22 | 42-43 | AO1 PEAK |
| 67 | 23 | 44-45 | AO2 PEAK |
| 67 | 24 | 46-47 | CARPET EDGE |

Table B-4. Measurements (ALL)

| Range | Description |
|--------|---|
| 0-1920 | Measurements are represented in 4x channel resolution |

AO1 PEAK and AO2 PEAK Measurements

The AO1 PEAK and AO2 PEAK measurements store the minimum/maximum values of Analog Output 1 and Analog Output 2 respectively. When the EZ-ARRAY's Analog Outputs are configured to have Peak Detect = Enabled and Peak Detect Reset = External Communications, then reading these measurements will reset the Analog Output Peak Detect value. To enable this mode of operation, the Analog Output's Configuration Flags must be configured as shown in Example 1 (see Table A-22).

Example 1. Analog Output Configuration Flags for Peak Detection with External Comm Reset

| SPDU Sub-Index | Bit Position | Flag | Description | Value |
|----------------|--------------|-----------------------|---------------------------------------|-------|
| 1 | 0 | Slope | 0 = Negative, 1 = Positive | X* |
| 2 | 1 | Measurement | 0 = Measurement 2, 1 = Measurement 1 | X |
| 3 | 2-3 | ZERO Value | 00 = Hold, 01 = Minimum, 10 = Maximum | XX |
| 4 | 4 | Peak Detect | 0 = Disabled, 1 = Enabled | 1 |
| 5 | 5 | Peak Detect Direction | 0 = Maximum, 1 = Minimum | X |
| 6 | 6 | Status | 0 = Disabled, 1 = Enabled | 1 |
| 7 | 7 | Peak Detect Reset | 0 = Auto, 1 = External Communications | 1 |

* X denotes a don't care value

6.6.3 Channel States

The Channel States section contains the state of all the channels in the EZ-ARRAY. Each sub-index represents 16 channels.

Table B-5. Channel States

| SPDU | | Byte Position | Member Name |
|-------|-----------|---------------|------------------|
| Index | Sub-Index | | |
| 65 | 1 | 0 | Channels 1-8 |
| 65 | 1 | 1 | Channels 9-16 |
| 65 | ... | ... | ... |
| 65 | 30 | 58 | Channels 465-472 |
| 65 | 30 | 59 | Channels 473-480 |

Table B-6. Channel States Bit-Mask

| Value | State | Description |
|-------|---------|-----------------------------|
| 0 | Made | The channel is made (clear) |
| 1 | Blocked | The channel is blocked |

For example, if the first and third beams of the EZ-ARRAY are blocked, Sub-Index 1 would contain the value 0x0005.

6.6.4 System Info and Status

The *System Info and Status* section contains the current status of the EZ-ARRAY.

Table B-7. System Info and Status

| SPDU | | Byte Position | Member Name |
|-------|----------------|---------------|-----------------------------|
| Index | Sub-Index | | |
| 66 | 1 | 0-1 | Number of Emitter Channels |
| 66 | 2 | 2-3 | Emitter First Bad Channel |
| 66 | 3 | 4-5 | Number of Receiver Channels |
| 66 | See Table B-12 | 8 | DIP Switch |
| 66 | 12 | 9 | ERROR Code |
| 66 | 13 | 10 | Alignment Status |
| 66 | See Table B-14 | 11 | Discrete Outputs |
| 66 | 17 | 12-13 | Analog Output 1 DAC |
| 66 | 18 | 14-15 | Analog Output 2 DAC |

Table B-9. Number of Emitter Channels

| Range | Description |
|--------|--|
| 30-480 | Number of channels the emitter has (multiples of 30) |

Table B-10. Emitter First Bad Channel

| Range | Description |
|-------|--|
| 0-480 | First channel that emitter is unable to fire (0 = no bad channels) |

Table B-11. Number of Receiver Channels

| Range | Description |
|--------|---|
| 30-480 | Number of channels the Receiver has (multiples of 30) |

Table B-12. DIP Switch

| SPDU Sub-Index | Bit Position | Function | Description |
|----------------|--------------|--------------|-----------------|
| 5 | 0 | DIP Switch 6 | 0 = ON, 1 = OFF |
| 6 | 1 | DIP Switch 5 | 0 = ON, 1 = OFF |
| 7 | 2 | DIP Switch 4 | 0 = ON, 1 = OFF |
| 8 | 3 | DIP Switch 3 | 0 = ON, 1 = OFF |
| 9 | 4 | DIP Switch 2 | 0 = ON, 1 = OFF |
| 10 | 5 | DIP Switch 1 | 0 = ON, 1 = OFF |

Table B-13. ERROR Code

| Value | Status |
|-------|---|
| 0 | System OK |
| 1 | Receiver EEPROM Hard Failure |
| 2 | Receiver Alignment/Blanking Configuration Error |
| 3 | Reserved for Factory 3 |
| 4 | Emitter or Wiring Problem |
| 5 | Emitter Channel Error |
| 6 | Reserved for Factory 6 |
| 7 | Reserved for Factory 7 |
| 8 | Reserved for Factory 8 |
| 9 | Reserved for Factory 9 |
| 10 | Incompatible Scan and Measurement Mode |

Table B-14. Alignment Status

| Value | Status |
|-------|---------|
| 0 | Failed |
| 1 | Success |

Table B-15. Discrete Outputs

| SPDU Sub-Index | Bit Position | Function | Description |
|----------------|--------------|-------------------|-----------------|
| 14 | 0 | Discrete Output 1 | 0 = OFF, 1 = ON |
| 15 | 1 | Discrete Output 2 | 0 = OFF, 1 = ON |

Table B-16. Analog Output 1 DAC & Analog Output 2 DAC

| Range | Description |
|--------|------------------------------------|
| 0-4095 | Current DAC value of analog output |

6.6.5 Receiver and Emitter Version Info

The *Receiver and Emitter Version Info* section contains the part numbers and versions of the receiver and emitter firmware.

Table B-17. Receiver and Emitter Version Info

| SPDU | | Byte Position | Member Name |
|-------|-----------|---------------|----------------------|
| Index | Sub-Index | | |
| 68 | 1 | 0-3 | Receiver Part Number |
| 68 | 2 | 4 | Receiver Version |
| 68 | 4 | 6-9 | Emitter Part Number |
| 68 | 5 | 10 | Emitter Version |

6.6.6 Communications Version Info

The *Communications Version Info* section contains the part number and version of the communications firmware.

Table B-18. Communications Version Info

| SPDU | | Byte Position | Member Name |
|-------|-----------|---------------|-------------|
| Index | Sub-Index | | |
| 69 | 1 | 0-3 | Part Number |
| 69 | 2 | 4 | Version |

6.6.7 Alignment/Blanking Routine

The Alignment/Blanking Routine section provides a state-machine for executing the Alignment and/or Blanking routines.

Table B-19. Alignment/Blanking Routine

| SPDU | | Byte Position | Member Name |
|-------|-----------|---------------|---------------------------|
| Index | Sub-Index | | |
| 92 | 1 | 0 | Alignment / Blanking Mode |

Table B-20. Alignment/Blanking Mode

| Value | State |
|-------|-----------------------|
| 0 | IDLE State |
| 1 | Access Alignment Mode |
| 2 | Alignment State |
| 3 | Exit Alignment Mode |
| 4 | Access Blanking Mode |
| 5 | Blanking State |
| 6 | Exit Blanking Mode |

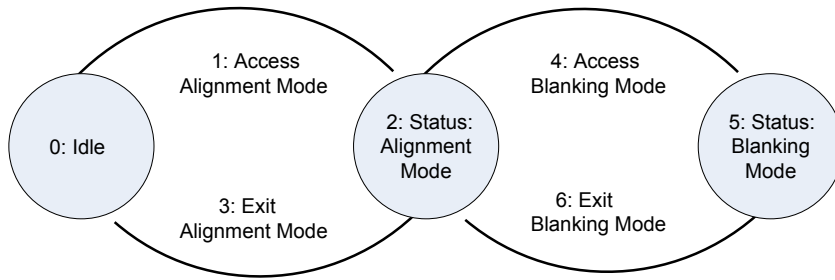
Figure B-1. Alignment/Blanking Mode State Machine

See [Overview: Electronic Alignment Routine](#) and [Overview: Blanking](#) for details on Alignment and Blanking routines. The Alignment Status can be read in the System Info and Status section to check if the Alignment routine was successful.