

M12 Series Metal Barrel Sensors



Rugged, self-contained sensors in a 12 mm threaded barrel

Features

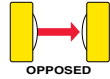

- Complete family of sensors, all housed in a compact 12 mm threaded metal barrel
- Opposed, retroreflective, polarized retroreflective, diffuse and 25, 50, or 75 mm cutoff fixed-field mode operation, depending on model
- Excellent background suppression on fixed-field models; an excellent alternative to proximity sensors
- Two Signal indicator LEDs for easy operating status monitoring from any direction
- 10 to 30V dc operation
- Complementary solid-state outputs (1 normally open, 1 normally closed); PNP (sourcing) or NPN (sinking), depending on model

Models

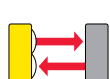
Sensing Mode	Model*	Range	Output
Opposed 	660 nm Visible Red Effective Beam: 10 mm (0.39") M12E	5 m (16.4')	N/A
	M12PR		PNP
	M12NR		NPN
Polarized Retro 	660 nm Visible Red M12PLP	1.5 m† (4.9')	PNP
	M12NLP		NPN
Retro 	660 nm Visible Red M12PLV	2.5 m† (8.2')	PNP
	M12NLV		NPN
Diffuse 	Performance based on use of 90% reflectance white test card.		
	660 nm Visible Red M12PD	400 mm (15.7")	PNP
M12ND	NPN		

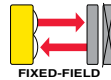
Sensing Mode	Model*	Range	Output	
Fixed-Field 	Performance based on use of 90% reflectance white test card.			
	680 nm Visible Red	M12PFF25	25 mm (1") cutoff;	PNP
		M12NFF25	25 mm (1") focus	NPN
	M12PFF50	50 mm (2") cutoff;	PNP	
		M12NFF50	25 mm (1") focus	NPN
	M12PFF75	75 mm (3") cutoff;	PNP	
M12NFF75		25 mm (1") focus	NPN	

*Only standard 2 m (6.5') cable models are listed. For 9 m (30') cable, add suffix "W/30" to the model number (e.g., **M12E W/30**).

QD models:

- 4-pin integral Euro-style M12 connector: add suffix "Q8" (e.g., **M12EQ8**).
- 4-pin 150 mm (6") Euro-style pigtail: add suffix "Q5" (e.g., **M12EQ5**).

†Retroreflective range is specified using one model **BRT-84** retroreflector. Actual sensing range may be more or less than specified, depending upon efficiency and reflective area of the retroreflector(s) used.

WARNING . . . Not To Be Used for Personnel Protection

Never use these products as sensing devices for personnel protection. Doing so could lead to serious injury or death.

These sensors do NOT include the self-checking redundant circuitry necessary to allow their use in personnel safety applications. A sensor failure or malfunction can cause either an energized or de-energized sensor output condition. Consult your current Banner Safety Products catalog for safety products which meet OSHA, ANSI and IEC standards for personnel protection.



M12 Series Metal Barrel Sensors

Overview

Banner's M12 family of sensors offers a full complement of sensing modes, all packaged in a compact yet rugged metal housing. Their popular 12-mm threaded barrel design allows them to mount easily into tight spaces, with the excellent performance expected of much larger sensors.

The single-turn Gain potentiometer on most models and two Signal LEDs (positioned on either side of the housing for visibility) provide easy alignment and configuration for reliable sensing (see Figure 1). Note that when the signal LED is not ON, the green Power LED is visible through all three LED ports.

Fixed-Field Mode Overview

M12 Series fixed-field sensors are powerful diffuse-mode sensors with far-limit cutoff (a type of background suppression). Their high excess gain and fixed-field technology allow them to detect objects of low reflectivity that are directly in front of another surface, while ignoring the surface in the background.

The cutoff distance is fixed. Backgrounds and background objects must *always* be placed beyond the cutoff distance.

Fixed-Field Sensing – Theory of Operation

In operation, the M12FF compares the reflections of its emitted light beam (E) from an object back to the sensor's two differently-aimed detectors R1 and R2 (see Figure 2). If the near detector (R1) light signal is stronger than the far detector (R2) light signal (see object A, closer than the cutoff distance), the sensor responds to the object. If the far detector (R2) light signal is stronger than the near detector (R1) light signal (see object B, object beyond the cutoff distance), the sensor ignores the object.

The cutoff distance for model M12FF sensors is fixed at 25, 50, or 75 mm (1", 2", or 3"). Objects lying beyond the cutoff distance are ignored, even if they are highly reflective. However, it is possible to falsely detect a background object, under certain conditions (see Background Reflectivity and Placement).

In the drawings and discussion on these pages, the letters E, R1, and R2 identify how the sensor's three optical elements (Emitter "E", Near Detector "R1", and Far Detector "R2") line up across the face of the sensor. The location of these elements defines the sensing axis (see Figure 3). The sensing axis becomes important in certain situations, such as those illustrated in Figures 6 and 7.

Fixed-Field Sensor Setup

Sensing Reliability

For best sensing reliability, the sensor-to-object distance should be positioned to maximize excess gain. The excess gain curves for these sensors are shown on page 5. Sensing at higher excess gains will make maximum use of the sensor's available sensing power. The background must be placed beyond the cutoff distance; more reflective backgrounds must be placed further back. Following these two guidelines will improve sensing reliability.

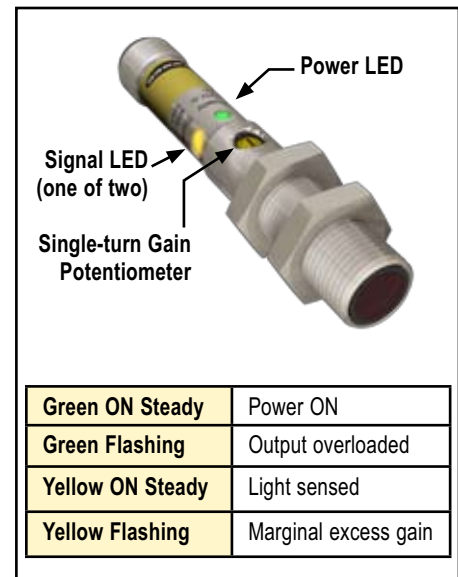

Figure 1. Features

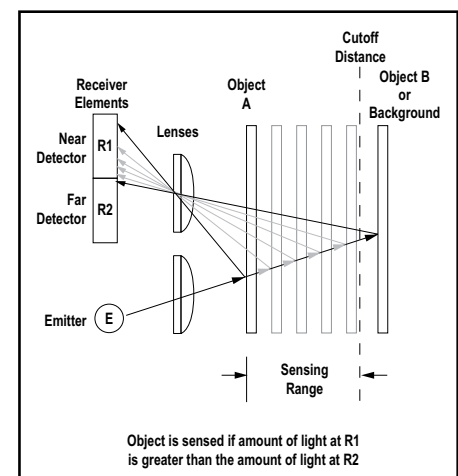

Figure 2. Fixed-field concept

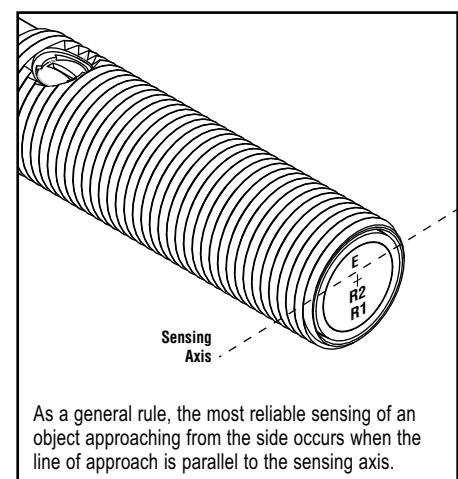

Figure 3. Fixed-field sensing axis

Background Reflectivity and Placement

Avoid mirror-like backgrounds that produce specular reflections. False sensor response will occur if a background surface reflects the sensor's light more strongly to the near detector, or "sensing" detector (R1) than to the far detector, or "cutoff" detector (R2). The result is a false ON condition (Figure 4). Use of a diffusely-reflective (matte) background will cure this problem. Other possible solutions are to angle the sensor or angle the background (in any plane) so the background does not reflect light back to the sensor (see Figure 5). Position the background as far beyond the cutoff distance as possible.

An object beyond the cutoff distance, either stationary (and when positioned as shown in Figure 6), or if it moves past the face of the sensor in a direction perpendicular to the sensing axis, can cause unwanted triggering of the sensor if it reflects more light to the near detector than to the far detector. The problem is easily remedied by rotating the sensor 90° (Figure 7). The object then reflects the R1 and R2 fields equally, resulting in no false triggering. A better solution, if possible, may be to reposition the object or the sensor.

Color Sensitivity

The effects of object reflectivity on cutoff distance, though small, may be important for some applications. It is expected that at any given cutoff setting, the actual cutoff distance for lower reflectance targets will be slightly shorter than for higher reflectance targets. This behavior is known as color sensitivity.

The excess gain curves on page 5 were generated using a white test card of 90% reflectance. Objects with reflectivity of less than 90% reflect less light back to the sensor, and thus require proportionately more excess gain in order to be sensed with the same reliability as more reflective objects. When sensing an object of very low reflectivity, it may be especially important to sense it at or near the distance of maximum excess gain.

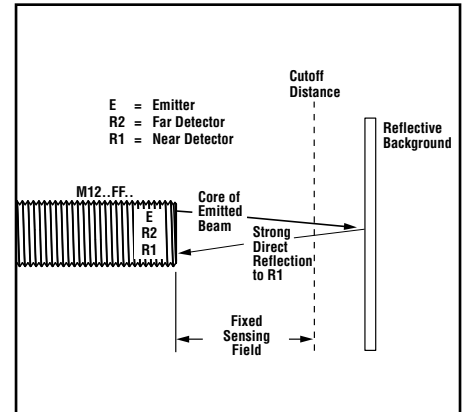

Figure 4. Reflective background – problem

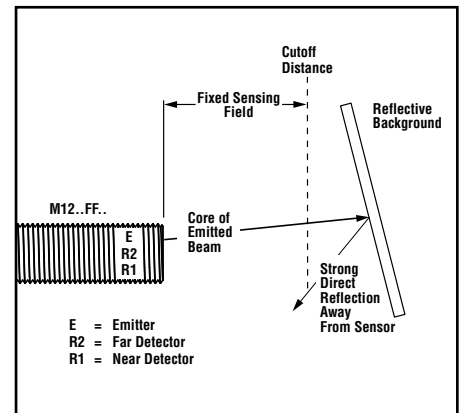

Figure 5. Reflective background – solution

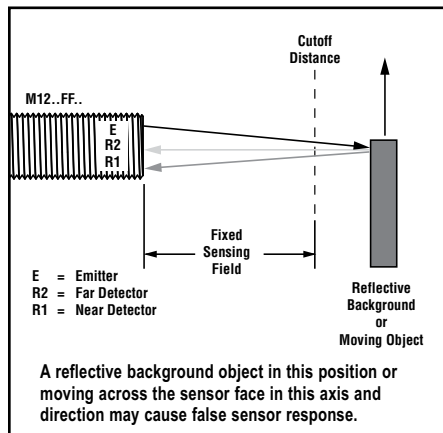

Figure 6. Object beyond cutoff – problem

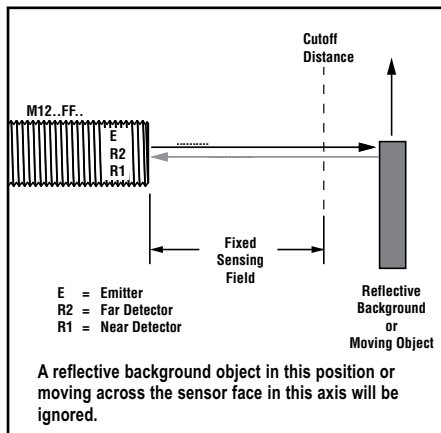



Figure 7. Object beyond cutoff – solution

M12 Series Metal Barrel Sensors

Specifications

Sensing Beam	Fixed-Field Models: 680 nm visible red All Other Models: 660 nm visible red
Supply Voltage and Current	10 to 30V dc (10% max. ripple) @ 20 mA max current, exclusive of load
Supply Protection Circuitry	Protected against reverse polarity and transient voltages
Output Configuration	Complementary (1 normally open and 1 normally closed) solid-state, NPN or PNP, depending on model
Output Ratings	100 mA total across both outputs with overload and short circuit protection OFF-state leakage current: ON-state saturation voltage: NPN: 200 μ A NPN: 1.6V @ 100 mA PNP: 10 μ A PNP: 3.0V @ 100 mA
Output Protection Circuitry	Protected against false pulse on power-up, short-circuit protected
Output Response Time	Opposed Mode: 1 ms ON and OFF All Other Modes: 500 μ s ON and OFF NOTE: 100 ms delay on power-up; outputs do not conduct during this time.
Repeatability	Opposed Mode: not applicable All Other Modes: 95 microseconds
Indicators	Two Status (yellow) and one Power (green) LED (see Figure 1)
Adjustments	Fixed-Field Models: None All Other Models: Single-turn Gain (sensitivity) potentiometer
Construction	Housing: Nickel-plated brass Lenses: PMMA Cable Endcap and Gain Potentiometer Adjuster: PBT
Environmental Rating	IEC IP67; NEMA 6, IEC IP68 and 1200 PSI Washdown, NEMA ICS 5 Annex F-2002
Connections	2 m (6.5') or 9 m (30') 4-wire PVC-jacketed cable, 4-pin integral Euro-style QD fitting, or 4-pin 150 mm (6") Euro-style pigtail, depending on model
Operating Conditions	Operating temperature: -20° to +60° C (-4° to +140° F) Relative humidity: 90% max @ +50° C (+122° F) non-condensing
Certifications	

M12 Series Metal Barrel Sensors

Performance Curves

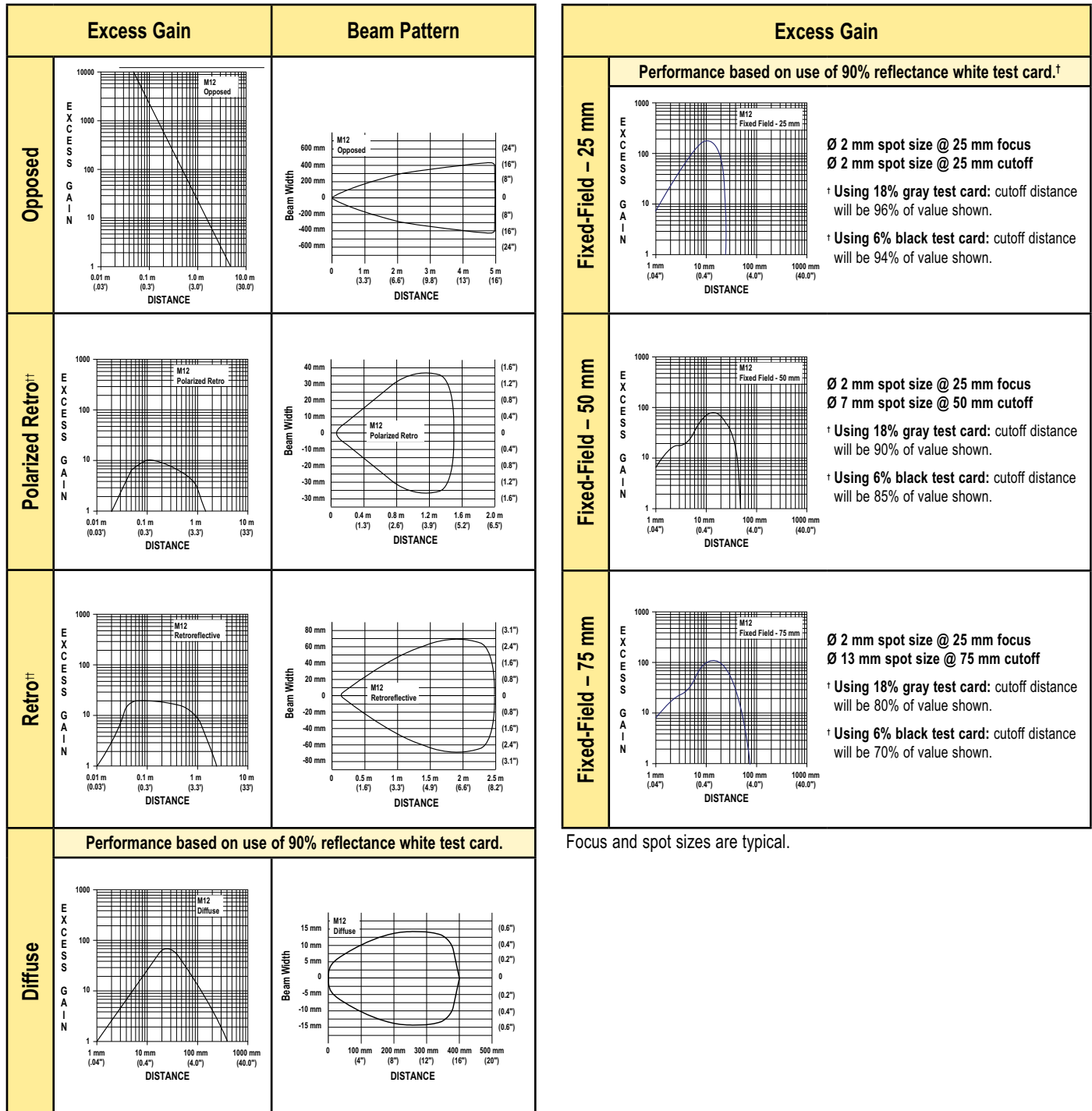

Focus and spot sizes are typical.

^{††}Performance based on use of a model BRT-84 retroreflector.

M12 Series Metal Barrel Sensors

Dimensions

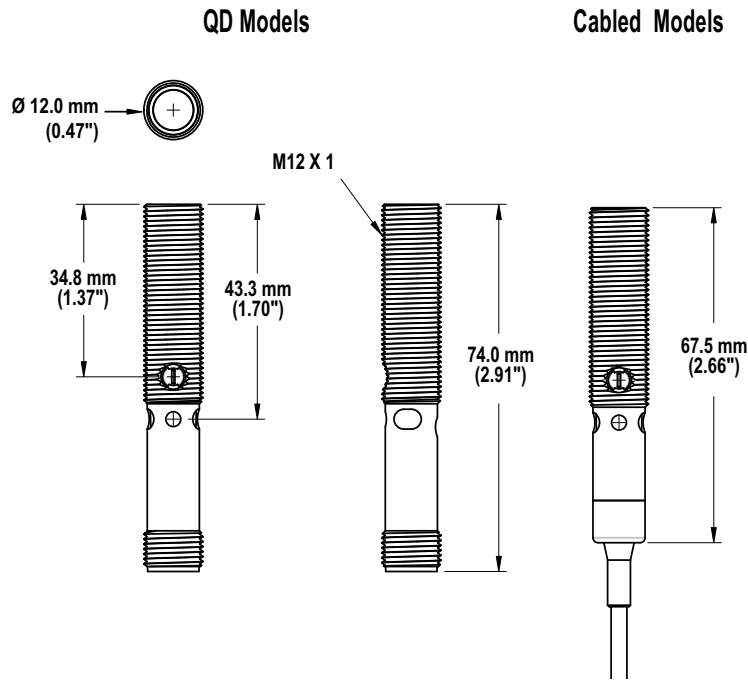

Hookups

Emitter

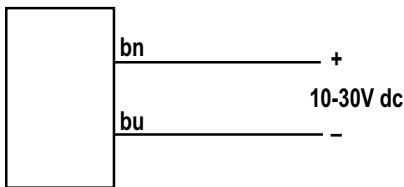

NPN (Current Sinking) Models

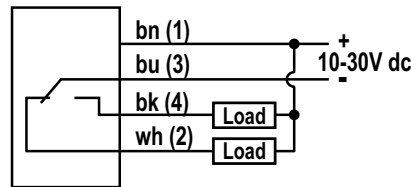

PNP (Current Sourcing) Models

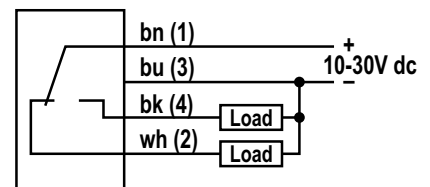

Cabled models are shown; QD hookups are functionally identical. (Emitters have no connection to bk and wh.)

M12 Series Metal Barrel Sensors

Quick-Disconnect (QD) Cables

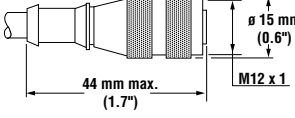
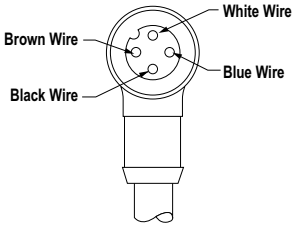
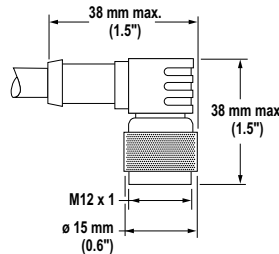
Style	Model	Length	Dimensions	Pinout
4-pin Euro-style straight	MQDC-406 MQDC-415 MQDC-430	2 m (6.5') 5 m (15') 9 m (30')		
4-pin Euro-style right-angle	MQDC-406RA MQDC-415RA MQDC-430RA	2 m (6.5') 5 m (15') 9 m (30')		

Mounting Brackets

SMBQS12PD	<ul style="list-style-type: none"> • Right-angle, barrel-mount bracket • 16-ga. 300 series stainless steel 	
------------------	--	--

M12 Series Metal Barrel Sensors



more sensors, more solutions

WARRANTY: Banner Engineering Corp. warrants its products to be free from defects for one year. Banner Engineering Corp. will repair or replace, free of charge, any product of its manufacture found to be defective at the time it is returned to the factory during the warranty period. This warranty does not cover damage or liability for the improper application of Banner products. This warranty is in lieu of any other warranty either expressed or implied.

P/N 129721 rev. C

Banner Engineering Corp., 9714 Tenth Ave. No., Minneapolis, MN USA 55441 • Phone: 763.544.3164 • www.bannerengineering.com • Email: sensors@bannerengineering.com

For Sales and Support, Contact Walker EMD • Toll-free: (800) 876-4444 • Tel: (203) 426-7700 • Fax: (203) 426-7800 • www.walkeremd.com