



more sensors, more solutions

R-GAGE™ QT50RAF* Sensor

Radar-Based Adjustable Field Sensors for Detection of Moving and Stationary Targets

Features



- FMCW (true-presence) radar detects moving and stationary objects
- Adjustable sensing field — ignores objects beyond the setpoint
- Sensing field is configured with simple DIP switches
- Sensing functions are unaffected by wind, rain, fog, light, humidity and air temperatures
- Sensor operates in Industrial, Scientific, and Medical (ISM) telecommunication band; no special license required
- Rugged IP67 housing withstands harsh environments

* Patent(s) issued or pending



Models

Models*	Maximum Range	Connection	Supply Voltage	Telecom Approval	Output
QT50RAF-US	15 m (49')	5-wire 2 m (6.5') Integral cable	12 to 30V dc	Telecom approved for US, Canada and Mexico	Bipolar NPN/PNP DIP-switch-selectable N.O. or N.C.
QT50RAF-CN				Telecom approved for China	
QT50RAF-EU				Telecom approved for Europe (except UK), Australia and New Zealand	
QT50RAF-UK				Telecom approved for UK	

* Cabled models only are listed. For integral 5-pin Euro-style (M12) quick-disconnect fitting, add suffix "Q" to the model number (e.g., **QT50RAFQ-xx**). QD models require a mating cordset; see [Quick-Disconnect \(QD\) Cordsets](#) on page 7.



Overview

The R-GAGE sensor emits a well-defined beam of high-frequency radio waves from an internal antenna. Some of this emitted energy reflects back to the receiving antenna. Signal processing electronics in the sensor determine the distance from the sensor to the object based on the time delay of the return signal. The sensor can be configured (via DIP switch) to sense objects up to a specific distance, ignoring objects beyond this distance (also called background suppression).

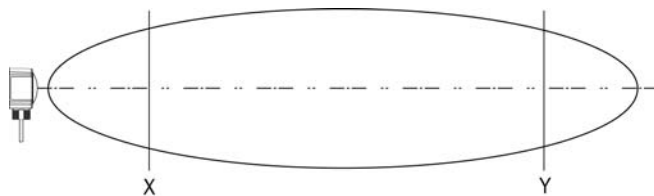

Figure 1. R-GAGE setpoint distances, minimum and maximum (sensor will detect objects up to setpoint and ignore objects beyond the setpoint)

- X) Minimum setpoint distance: 2 m (EU models); 3 m (all other models)
- Y) Maximum setpoint distance: 15 m (all models)

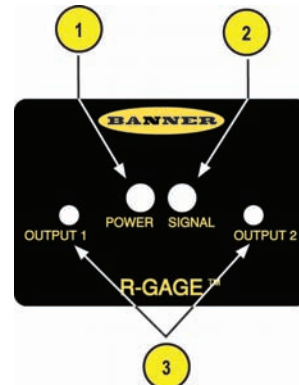

Figure 2. R-GAGE features

1. Power LED: Green (power ON)
2. Signal Strength LED: Red (flashes in proportion to signal strength)
3. Output LEDs: Yellow (output energized); Red (configuration)

Access DIP switches behind threaded cap on sensor back (not shown)

Sensor Configuration

The sensing zone distance, sensitivity and output configuration can be selected via the DIP switches on the back of the sensor.

Use the included spanner to open the screw-off cover on the back of the sensor and access the DIP switches.

* Default settings

DIP Switch Functions

Switch	Function
1, 2, 3	Sensing distance (detects objects from sensor face to this point)
4, 5, 6	Sensitivity (higher sensitivity sees weaker objects and has a wider beam pattern)
7	Normally open/normally closed output functionality
8	Response speed

Sensing Distance Settings

Switch 1	Switch 2	Switch 3	Distance	
			EU, CN Models	US, UK Models
0	0	0	2 m	3 m
0	0	1	3 m	4 m
0	1	0	4 m	5 m
0	1	1	6 m	6 m
1*	0*	0*	8 m	8 m
1	0	1	10 m	10 m
1	1	0	12 m	12 m
1	1	1	15m	15 m

NOTE: Highest sensitivity is achieved only if sensing distance is 8 m or less

Sensitivity Selection

Switch 4	Switch 5	Switch 6	Sensitivity
0*	0*	0*	8* (Highest)
0	0	1	7
0	1	0	6
0	1	1	5
1	0	0	4
1	0	1	3
1	1	0	2
1	1	1	1 (Lowest)

Output Configuration

Switch 7	Normally Open/Normally Closed
0*	N.O.
1	N.C.

Response Speed

Switch 8	ON	OFF	ON/OFF
0	32 ms	68 ms	100 ms
1*	258 ms	998 ms	1256 ms

Specifications

Feature	Description
Range	The sensor is able to detect a proper object (see below) up to 15 meters, depending on target.
Detectable Objects	Objects containing metal, water, or similar high-dielectric materials.
Operating Principle	Frequency modulated continuous-wave (FMCW) radar
Operating Frequency	24.00 to 24.25 GHz, ISM Band (varies slightly with model, depending on national telecom regulations)
Supply Voltage	12 to 30V dc, less than 100 mA, exclusive of load
Supply Protection Circuitry	Protected against reverse polarity and transient overvoltages
Delay at Power-up	Less than 2 seconds
Output Configuration	Bipolar NPN/PNP output, 150mA; DIP switch 7 selects N.O. (default) or N.C. operation
Output Protection	Protected against short circuit conditions
Indicators	<p>Power LED: Green (power ON)</p> <p>Signal Strength LED: Red, flashes in proportion to signal strength. Steady on at 4x the sensitivity adjusted baseline (indicating 4x excess gain). Only indicates signal amplitude, not target distance.</p> <p>Output LEDs: Yellow (output energized)/Red configuration</p> <p>See Figure 2.</p>
Response time	DIP-switch 8 selects ON/OFF response time
Adjustments	DIP-switch-configurable sensing distance, sensitivity and output configuration
Construction	<p>Housing: ABS/polycarbonate</p> <p>Lightpipes: Acrylic</p> <p>Access Cap: Polyester</p>
Operating Temperature	-40° to +65° C (-40° to +149° F)
Environmental Rating	IP67
Connections	Integral 5-wire 2 m (6.5') cable or M12 Euro-style QD fitting. QD models require a mating cordset; see page 4.
Certifications	 and ETSI/EN 300 440; FCC part 15; Industry Canada; for others, consult the Factory.

Beam Pattern

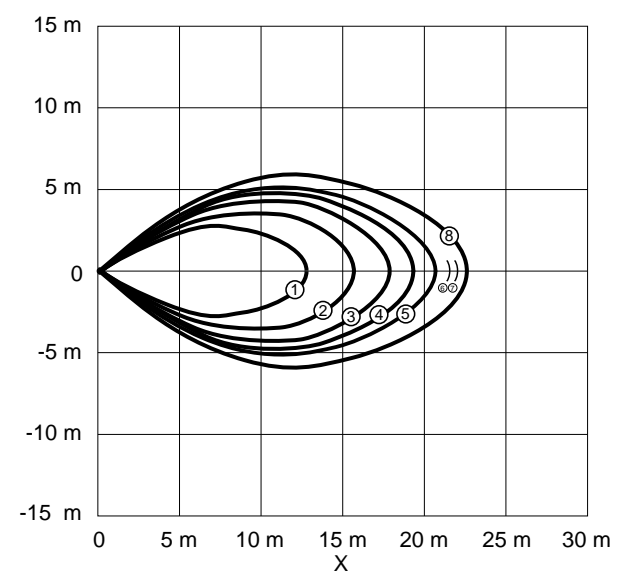
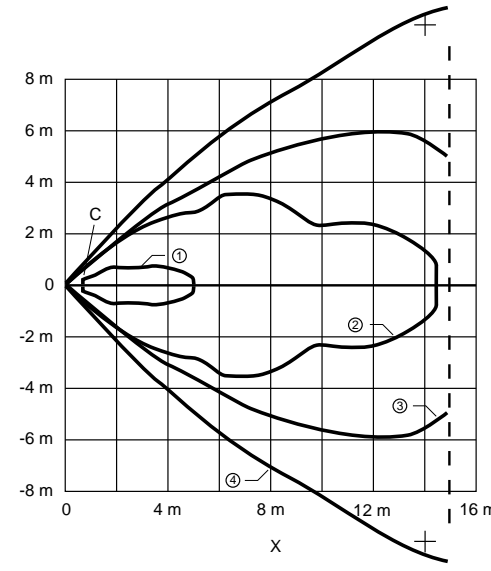
Typical Beam Pattern (with BRTR-CC20E Radar Target, RCS = 50 m ²)	Typical Beam Pattern (with 4 different targets) at sensitivity level 8
	
<p>1-8: Indicates sensitivity level</p> <p>X: Distance</p>	<p>1: Weak Object - RCS = 0.25 m²</p> <p>2: Car - RCS = 3 m²</p> <p>3: Large Truck - RCS = 50 m²</p> <p>4: Passenger Train - RCS = 300 m²</p> <p>C: Cutoff at 1 m</p>
<p>NOTE: The effective beam pattern depends on sensitivity level and target properties.</p>	

Dimensions

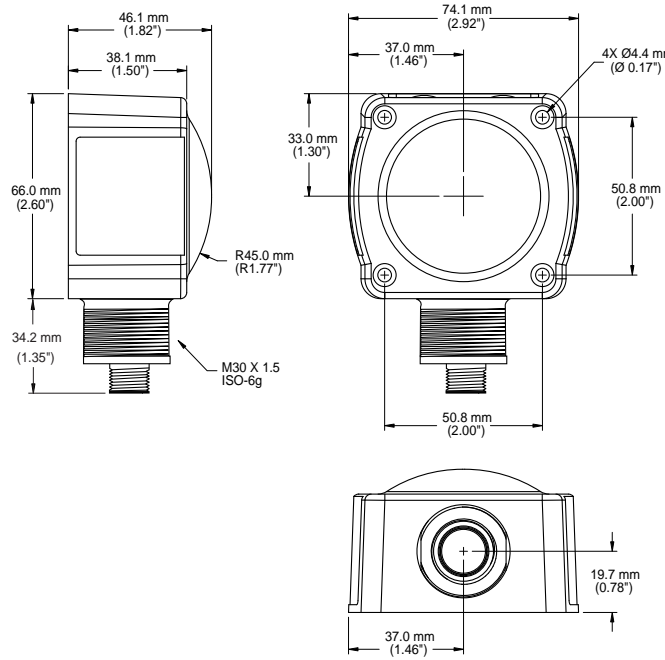

Hookup

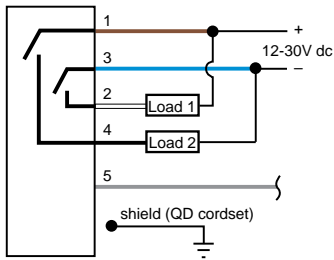

Wiring Key:

- 1 = Brown
- 2 = White
- 3 = Blue
- 4 = Black
- 5 = Gray (Do not connect)

NOTE: It is recommended that the shield wire (QD cordsets only) be connected to earth ground or dc common. Shielded cordsets are recommended for all QD models.

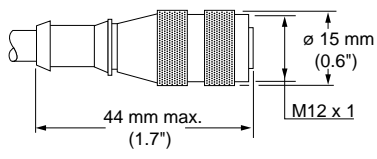
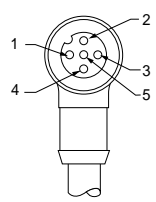
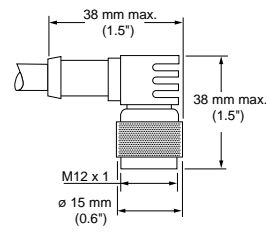

Quick-Disconnect (QD) Cordsets

Style	Model	Length	Dimensions	Pinout
5-pin Euro-style straight with shield	MQDEC2-506	2 m (6.5')		Female
	MQDEC2-515	5 m (15')		
	MQDEC2-530	9 m (30')		
5-pin Euro-style right-angle with shield	MQDEC2-506RA	2 m (6.5')		1 = Brown
	MQDEC2-515RA	5 m (15')		2 = White
	MQDEC2-530RA	9 m (30')		3 = Blue
				4 = Black
				5 = Gray (not used)

Weather Deflector

Model	Description
QT50RCK	<ul style="list-style-type: none"> • Required if the R-GAGE is exposed to rain or snow • Prevents buildup of water or ice from interfering with sensor performance 

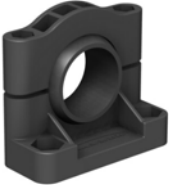
Mounting Brackets

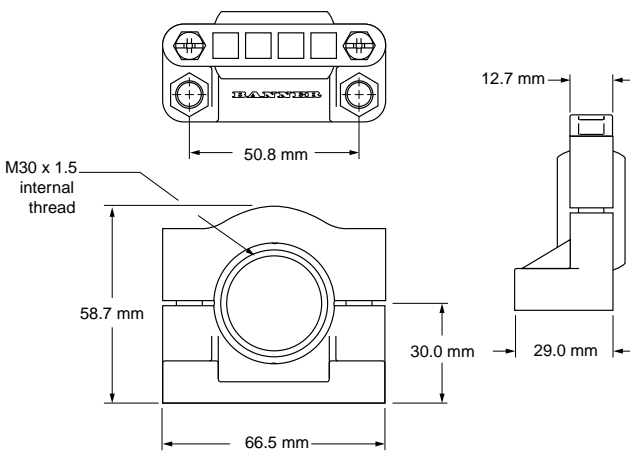
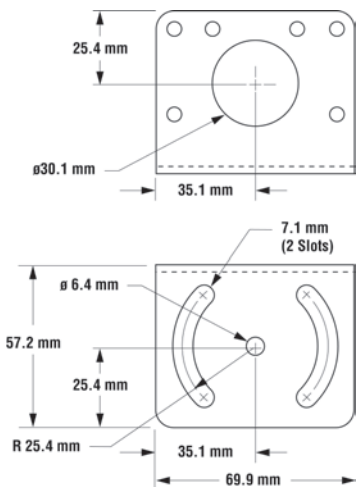
<p>SMB30SC</p> <ul style="list-style-type: none"> 30 mm split clamp with swivel, black reinforced thermoplastic polyester Stainless steel hardware included 		<p>SMB30MM</p> <ul style="list-style-type: none"> 30 mm, 11-gauge, stainless steel bracket with curved mounting slots for versatile orientation Clearance for M6 (1/4") hardware 	
			

 **Caution...Make No Modifications to this Sensor**

Any modifications to this sensor not expressly approved by Banner Engineering could void the user's authority to operate the sensor. **Contact the Factory for more information.**

 **WARNING . . . Not To Be Used for Personnel Protection**

Never use this product as a sensing device for personnel protection. Doing so could lead to serious injury or death

This product does NOT include the self-checking redundant circuitry necessary to allow its use in personnel safety applications. A sensor failure or malfunction can cause either an energized or deenergized sensor output condition. Consult your Banner Safety Products catalog for safety products that meet OSHA, ANSI and IEC standards for personnel protection.



Warranty: Banner Engineering Corporation warrants its products to be free from defects for a period of one year. Banner Engineering Corporation will repair or replace, free of charge, any product of its manufacture found to be defective at the time it is returned to the factory during the warranty period. This warranty does not cover damage or liability for the improper application or installation of Banner products. This warranty is in lieu of any other warranty either expressed or implied.