

Because of their extremely high excess gain, these opposed-mode sensors are an excellent option for sensing in contaminated or dirty areas, and are also the best choice for long-range sensing.



Infrared, 880 nm

Q45BW13 Series Features

- Advanced one-piece photoelectric sensors with outstanding optical performance and extremely rugged design
- Universal supply voltage: 12 to 250V dc or 24 to 250V ac
- Opto-isolated solid-state relay output; 300 mA max. load at up to 250V ac, 250V dc
- Full line includes opposed, diffuse, retroreflective, convergent, and glass and plastic fiber optic sensing modes
- Switchable light/dark operate
- Versatile plug-in modules available for output timing logic and/or signal strength display
- Highly visible Power, Signal (AID™ System), and Output indicator LEDs
- Choice of prewired 2 m (6.5') or 9 m (30') unterminated cable or Mini-style quick-disconnect fitting
- Versatile mounting options
- Designed to withstand 1200 psi washdown; exceeds its NEMA 6P and IEC IP67 rating

*U.S. Patent no. 4356393

Q45BW13 Series Opposed-Mode Emitter (E) and Receiver (R) Models

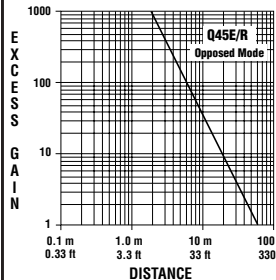
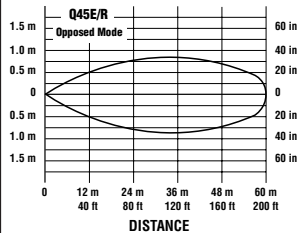
Models	Range	Cable	Supply Voltage	Output Type	Excess Gain	Beam Pattern
Q453E Emitter	60 m (200')	2-wire 2m (6.5')	Universal 12 - 250V dc or 24 - 250V ac	Isolated SPST Solid-state Switch		
Q45BW13R Receiver		4-wire 2m (6.5')				
Q453EQ Emitter		3-Pin Mini-style QD				
Q45BW13RQ Receiver		4-Pin Mini-style QD				

NOTES: i) 9 m (30') cables are available by adding suffix "W/30" to the model number of any cabled sensor (e.g., Q453E W/30)
 ii) A model with a QD connector requires a mating cable; see page 10.

IMPORTANT: SEE SAFETY USE WARNING ON BACK PAGE

Q45BW13 Series

The visible red sensing beam of these sensors makes them very easy to align. Model Q45BW13LP polarizes the emitted light and filters out unwanted reflections, making sensing possible in applications otherwise considered unsuited to retroreflective sensing. Performance is specified using the model BRT-3 3" reflector (see the Accessories section of your current Banner Photoelectric Sensors catalog for further information).

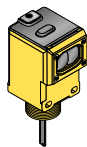

Q45BW13 Series Retroreflective-Mode Models

Models	Range	Cable	Supply Voltage	Output Type	Excess Gain	Beam Pattern
Non-Polarized						
Q45BW13LV Q45BW13LVQ	0.08 to 9 m (3" to 30')	4-wire 2 m (6.5') 4-Pin Mini-style QD	Universal 12 - 250V dc or 24 - 250V ac	Isolated SPST Solid-state Switch		
Polarized						
Q45BW13LP Q45BW13LPQ	0.15 to 6 m (6" to 20')	4-wire 2 m (6.5') 4-Pin Mini-style QD	Universal 12 - 250V dc or 24 - 250V ac	Isolated SPST Solid-state Switch		

NOTES:

- i) 9 m (30') cables are available by adding suffix "W/30" to the model number of any cabled sensor (e.g., **Q45BW13LV W/30**)
- ii) A model with a QD connector requires a mating cable; see page 10.

Q45BW13 Series

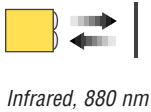

These diffuse-mode models detect objects by sensing the reflection of their own emitted light. Ideal for use when the reflectivity and profile of the object to be sensed are sufficient to return a large percentage of emitted light back to the sensor. Model Q45BW13DX is the first choice for diffuse-mode applications when there are no background objects to falsely return light.

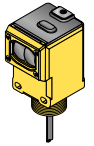

Q45BW13 Series Diffuse-Mode Models

Models	Range	Cable	Supply Voltage	Output Type	Excess Gain	Beam Pattern
					Performance based on 90% reflectance white test card	
Short Range						
Q45BW13D Q45BW13DQ	450 mm (18")	4-wire 2 m (6.5') 4-Pin Mini-style QD	Universal 12 - 250V dc or 24 - 250V ac	Isolated SPST Solid-state Switch		
Long Range						
Q45BW13DL Q45BW13DLQ	1.8 m (6')	4-wire 2 m (6.5') 4-Pin Mini-style QD	Universal 12 - 250V dc or 24 - 250V ac	Isolated SPST Solid-state Switch		
High Power						
Q45BW13DX Q45BW13DXQ	3 m (10')	4-wire 2 m (6.5') 4-Pin Mini-style QD	Universal 12 - 250V dc or 24 - 250V ac	Isolated SPST Solid-state Switch		

Q45BW13 Series

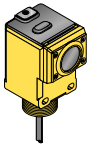

These sensors are ideal for reflective sensing of very small parts or profiles, and can accurately sense the position of parts approaching from the side. Will ignore all but highly reflective objects that are outside the sensing range.

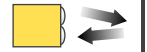

Visible red. 680 nm

Q45BW13 Series Convergent-Mode Models

Models	Focus	Cable	Supply Voltage	Output Type	Excess Gain	Beam Pattern
					Performance based on 90% reflectance white test card	
Q45BW13CV Q45BW13CVQ	38 mm (1.5") Spot Size at Focus: 1.3 mm (0.05")	4-wire 2 m (6.5') 4-Pin Mini-style QD	Universal 12 - 250V dc or 24 - 250V ac	Isolated SPST Solid-state Switch		
Q45BW13CV4 Q45BW13CV4Q	100 mm (4") Spot Size at Focus: 1.5 mm (0.06")	4-wire 2 m (6.5') 4-Pin Mini-style QD	Universal 12 - 250V dc or 24 - 250V ac	Isolated SPST Solid-state Switch		

NOTES:

- i) 9 m (30') cables are available by adding suffix "W/30" to the model number of any cabled sensor (e.g., **Q45BW13CV W/30**)
- ii) A model with a QD connector requires a mating cable; see page 10.

Q45BW13 Series

These models are an excellent choice for glass fiber optic applications where faster sensor response is not important. Their high excess gain means that opposed individual fibers can operate reliably in many very hostile environments. Also, special miniature bifurcated fiber optic assemblies with bundle sizes as small as .5 mm (.020") dia. may be used successfully for diffuse-mode sensing when using sensor model Q45BW13F(Q). For more information on compatible glass fiber optics, refer to your current Banner Photoelectric Sensors catalog.

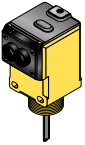

Infrared, 880 nm and Visible Red, 650 nm

Q45BW13 Series Glass Fiber-Optic Models

Models	Range	Cable	Supply Voltage	Output Type	Excess Gain		Beam Pattern	
					Diffuse mode performance based on 90% reflectance white test card			
Infrared, 880 nm								
Q45BW13F	Range varies by sensing mode and fiber optics used	4-wire 2 m (6.5')	Universal 12 - 250V dc or 24 - 250V ac	Isolated SPST Solid-state Switch				
Q45BW13FQ		4-Pin Mini-style QD						
Visible Red, 650 nm								
Q45BW13FV	Range varies by sensing mode and fiber optics used	4-wire 2 m (6.5')	Universal 12 - 250V dc or 24 - 250V ac	Isolated SPST Solid-state Switch				
Q45BW13FVQ		4-Pin Mini-style QD						

Q45BW13 Series

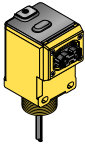

Lower in cost than glass fiber optics, plastic fiber optics are ideal for use in situations where environmental conditions allow (for example, low levels of acids, alkalis, and solvents). Most are easily cut to length in the field, and are available in a variety of sensing end styles. For more information on compatible plastic fiber optics, refer to your current Banner Photoelectric Sensors catalog.



Visible red, 660 nm

Q45BW13 Series Plastic Fiber-Optic Models

Models	Range	Cable	Supply Voltage	Output Type	Excess Gain	Beam Pattern
					Diffuse mode performance based on 90% reflectance white test card	
Q45BW13FP Q45BW13FPQ	Range varies by sensing mode and fiber optics used	4-wire 2 m (6.5') 4-Pin Mini-style QD	Universal 12 - 250V dc or 24 - 250V ac	Isolated SPST Solid-state Switch		

NOTES:

- i) 9 m (30') cables are available by adding suffix "W/30" to the model number of any cabled sensor (e.g., Q45BW13FP W/30)
- ii) A model with a QD connector requires a mating cable; see page 10.

Q45BW13 Series Specifications

Supply Voltage and Current	Universal voltage: 24 to 250V ac, 50/60 Hz or 12 to 250V dc (1.5 watts maximum)
Supply Protection Circuitry	Protected against transient voltages. DC hookup is without regard to polarity.
Output Configuration	All models except emitters: Optically isolated SPST solid-state switch
Output Rating	250V ac, 250V dc, 300 mA Output saturation voltage: 3V at 300 mA, 2V at 15 mA Off-state leakage current: <50 microamps Inrush current: 1 amp for 20 milliseconds, non-repetitive
Output Protection Circuitry	Protected against false pulse on power-up
Output Response Time	Opposed mode: 2 milliseconds on, 1 millisecond off All other sensing modes: 2 milliseconds on/off (NOTE: 100 millisecond delay on power-up. Output is non-conducting during this time.)
Repeatability	Opposed mode: 0.25 milliseconds All other sensing modes: 0.5 milliseconds Response time and repeatability specifications are independent of signal strength.
Adjustments	Light/Dark Operate select switch; and multi-turn Sensitivity control on top of sensor beneath a transparent o-ring-sealed Lexan® cover, allows precise sensitivity setting (turn clockwise to increase gain). Optional logic and logic/display modules have adjustable timing functions (see page 10).
Indicators	Indicator LEDs are clearly visible beneath a raised transparent Lexan® dome on top of the sensor. Power (green) LED lights whenever 24 to 250V ac, or 12 to 250V dc power is applied Signal (red) AID™ System LED lights whenever the sensor sees its modulated light source, and pulses at a rate proportional to the strength of the received light signal Load (yellow) LED lights whenever the output relay is energized Optional 7-element LED signal strength display module
Construction	Molded reinforced thermoplastic polyester housing, o-ring-sealed transparent Lexan® cover, molded acrylic lenses, and stainless steel hardware. Q45s are designed to withstand 1200 psi washdown. The base of cabled models has a 1/2" NPS integral internal conduit thread.
Environmental Rating	NEMA 6P, IEC IP67
Connections	PVC-jacketed 2 m (6.5') or 9 m (30') unterminated cables, or Mini-style quick-disconnect (QD) fittings are available ("Q"- suffix models). QD cables are ordered separately. See page 10.
Operating Conditions	Temperature: -25° to +55° C (-13° to +131°F) Maximum relative humidity: 90% at 50°C (non-condensing)
Application Notes	Optional output timing modules are available. See page 10 for more information. Output is not short-circuit protected. Exercise care when making wiring connections.
Certifications	

Lexan® is a registered trademark of General Electric Co.

Q45BW13 Series

Q45BW13 Series Dimensions

Q45BW13 Series Sensors – Opposed, Retro, and Diffuse Sensing Modes (model suffix E, R, D, DL, DX, LP & LV)

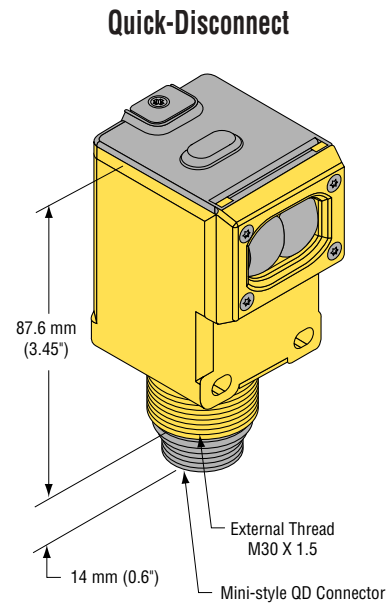
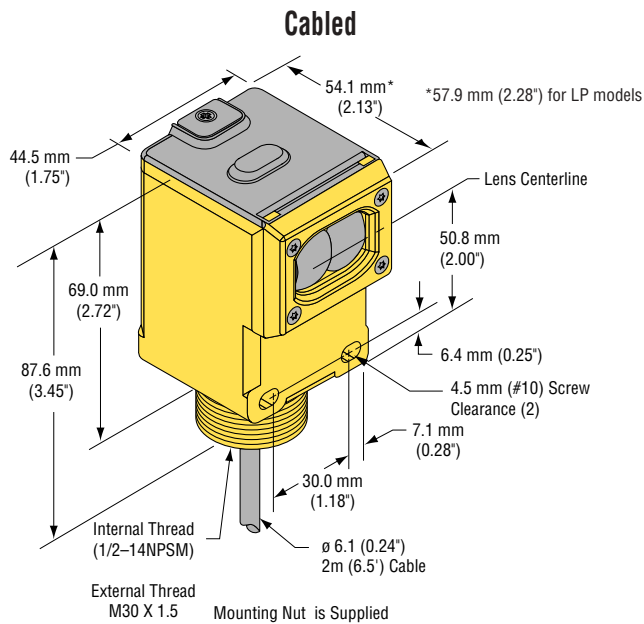

Convergent Sensing Mode (model suffix CV & CV4)

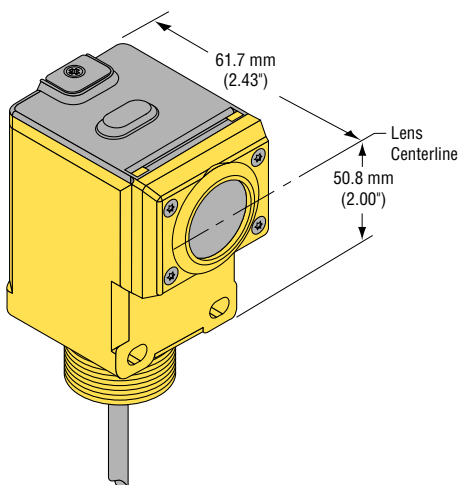

Glass Fiber Optic (model suffix F and FV)

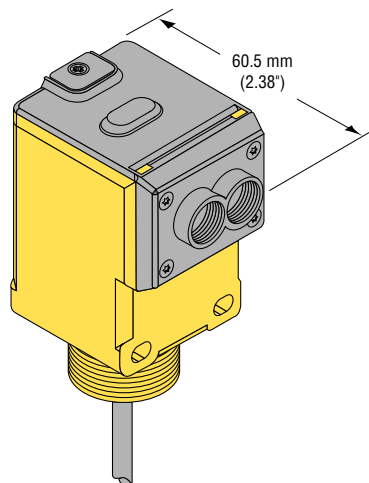

Plastic Fiber Optic (model suffix FP)

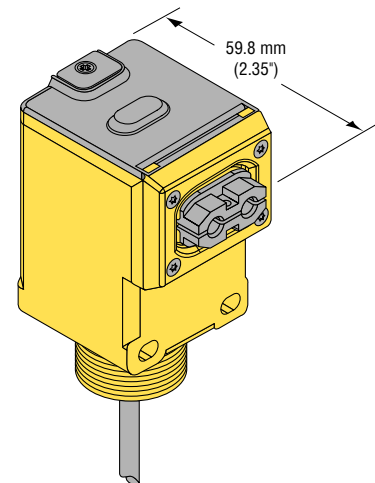

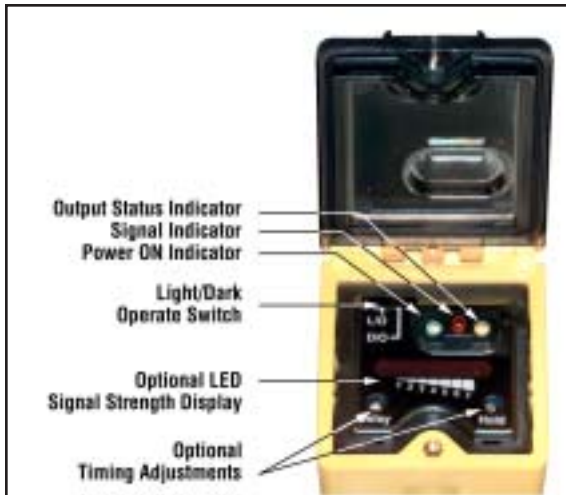

Figure 1. Indicators and controls on the Q45BW13 series sensors

Q45BW13 Series Indicators and Controls

Status indicator LEDs for Power, Signal and Output are clearly visible beneath a raised dome in the sensor's transparent o-ring-sealed Lexan® cover. The Power indicator lights whenever power is applied to the sensor. The Signal LED lights whenever the sensor sees its modulated light source, and pulses at a rate proportional to the strength of the received light signal; this is the AID™ Alignment Indicating Device*. The Output indicator lights whenever the sensor's output relay is energized. This indicator is especially useful when a timing logic module is used and Signal and Output conditions are not concurrent.

Also located beneath the sensor's o-ring-sealed cover are controls for light/dark operate selection and Sensitivity adjustment.

* US patent no. 4356393

Q45BW13 Series Hookups

Q45BW13 Sensors with Attached Cable

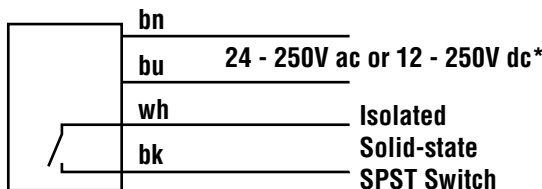

Q45BW13 Sensors with Quick-Disconnect 4-Pin Mini-Style (model suffix Q)

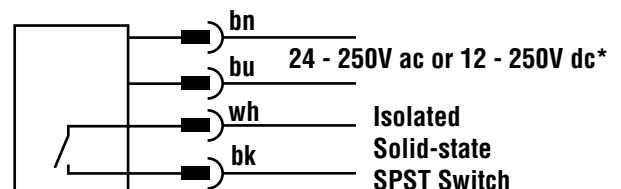

Q453E Emitter with Attached Cable

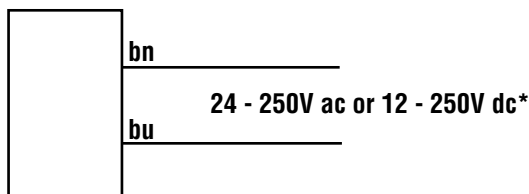

*NOTE: Connection of dc power is without regard to polarity.

Q453EQ Emitter with Quick-Disconnect 3-Pin Mini-Style

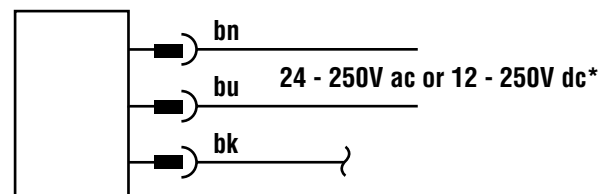

Quick-Disconnect (QD) Option

AC Q45BW13 Series sensors are sold with either a 2 m (6.5') or a 9 m (30') attached PVC-covered cable, or with a 3-pin Mini-style (opposed mode emitter) or 4-pin Mini-style Quick-Disconnect (QD) cable fitting.

Mini-style QD sensors are identified by the suffix "Q" in their model number suffix. Mating cables for QD Q45BW13 sensors are specified on page 10.

Q45BW13 Series

Accessories

Mini-Style Quick-Disconnect Cables

Cable: PVC jacket, polyurethane connector body, nylon coupling nut
Conductors: 18 AWG high-flex stranded, PVC insulation, gold plated contacts
Temperature: -40 to +80°C (-40 to +176°F)
Voltage Rating: 250V ac/300V dc

Style	Model	Length	Dimensions	Pin-Out (Female View)
3-Pin Female Pin-out Straight	MBCC-306 MBCC-312 MBCC-330	2 m (6.5') 4 m (12') 9 m (30')		
4-Pin Female Pin-out Straight	MBCC-406 MBCC-412 MBCC-430	2 m (6.5') 4 m (12') 9 m (30')		

Retroreflective Targets

Banner offers a wide selection of high-quality retroreflective targets. See the Accessories section of your current Banner Photoelectric Sensors catalog for complete information.

NOTE: Polarized sensors require corner cube type retroreflective targets only. Non-polarized sensors may use any retroreflective target.

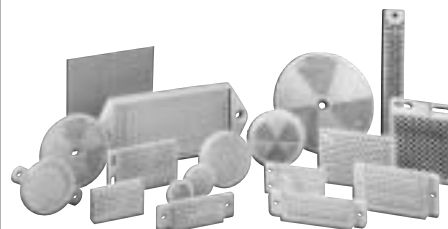

Output Timing Logic and Signal Strength Display Modules

Q45 sensors easily accept the addition of output timing logic and signal strength display functions. Display modules have a seven-element display which gives a more precise indication of excess gain than does the AID™ system LED that is standard on Q45 sensors. The modules listed below may be used with all Q45BW13 Series sensors. See the data sheet packed with the module for more information.

Model	Logic and/or Display Function	
45LM58 45LM58D 45LMD	Programmable output timing logic Programmable output timing logic plus signal strength display Signal strength display only (no timing function)	

Mounting Brackets		
Model	Description	Dimensions
SMB30C	<ul style="list-style-type: none"> • 30 mm split clamp, black PBT bracket • Stainless steel mounting hardware included 	
SMB30MM	<ul style="list-style-type: none"> • 30 mm, 11-gauge, stainless steel bracket with curved mounting slots for versatility and orientation • Clearance for M6 (1/4") hardware 	
SMB30SC	<ul style="list-style-type: none"> • 30 mm swivel, black PBT bracket • Stainless steel mounting hardware included 	

Q45BW13 Series



WARRANTY: Banner Engineering Corp. warrants its products to be free from defects for one year. Banner Engineering Corp. will repair or replace, free of charge, any product of its manufacture found to be defective at the time it is returned to the factory during the warranty period. This warranty does not cover damage or liability for the improper application of Banner products. This warranty is in lieu of any other warranty either expressed or implied.



WARNING . . . Not To Be Used for Personnel Protection

Never use these products as sensing devices for personnel protection. Doing so could lead to serious injury or death.

These sensors do NOT include the self-checking redundant circuitry necessary to allow their use in personnel safety applications. A sensor failure or malfunction can cause either an energized or de-energized sensor output condition. Consult your current Banner Safety Products catalog for safety products which meet OSHA, ANSI and IEC standards for personnel protection.