

130 Series Reversing Control

For PM and Shunt Wound DC Motors through 2 HP

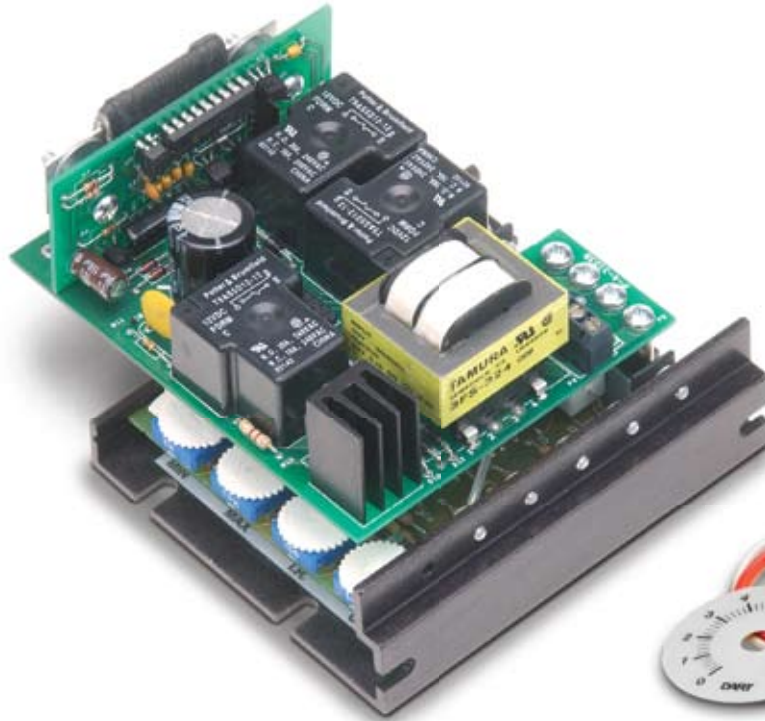

Speed Potentiometer
Kit Included



Instant reversing, quick stopping, rapid cycling... The 130 Series reversing control outperforms other dynamic braking and reversing controls by utilizing Dart's unique zero-speed detect and dynamic braking circuits. These circuits eliminate the contact arcing and failed braking problems associated with other reversing and dynamic braking controls. Dart's zero speed detect circuit also eliminates motor plug reversing problems.

In the event of a power loss or emergency stop condition, the 130 Series control will drop into a dynamic brake condition to safely and quickly bring the motor to a stop and remain there until power is reapplied and a run condition is recognized.



130 SERIES STANDARD FEATURES

- Adjustable horsepower settings
- Barrier terminal blocks
- Full wave bridge supply
- Adjustable Min speed (0-30% of max)
- Adjustable Max speed (66-100% of base)
- Adjustable IR compensation
- Adjustable current limit
- Fixed accel (0.5 sec)
- Line voltage compensation
- 5K speed pot with leads, dial and knob included
- 50:1 speed range
- Overload capacity: 200% for one minute
- Transient voltage protection
- Shunt field supply provided (1 Amp max; 100V for 120 VAC input or 200V for 240 VAC input)
- Onboard dynamic brake resistor
- Automatic dynamic braking on power loss
- 1% speed regulation with armature voltage feedback

130 SERIES OPERATING CONDITIONS

Temperature..... -10° to +45° C
 AC Input Voltage ±10% Rated Line Voltage
 Input Frequency 50/60 Hz

TYPICAL APPLICATIONS

- Door Openers
- Feeders
- Tapping Machines
- Pumps
- Screen Presses
- Conveyors

130 SERIES MODEL NUMBERS AND RATINGS

MODEL	INPUT VOLTAGE	OUTPUT HP RANGE	CYCLE AMPS DC	RATE
130LC12	120 VAC	1/15-1/8	1.2	3 C/MIN
130LC100	120 VAC	1/8-1/2	5.5	3 C/MIN
130HC12	120 VAC	1/15-1/8	1.2	UP TO 30 C/MIN
130HC100	120 VAC	1/8-1.0	10.0	UP TO 30 C/MIN
132LC25	240 VAC	1/25-1/4	1.2	3 C/MIN
132LC200	240 VAC	1/8-1.0	5.5	3 C/MIN
132HC25	240 VAC	1/25-1/4	1.2	UP TO 30 C/MIN
132HC200	240 VAC	1/4-2.0	10.0	UP TO 30 C/MIN

130 SERIES MECHANICAL SPECIFICATIONS, ADJUSTMENTS AND HOOK-UPS

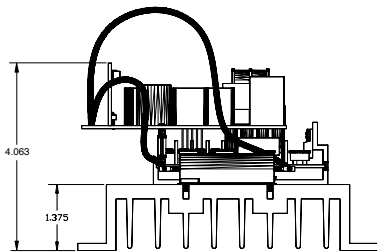
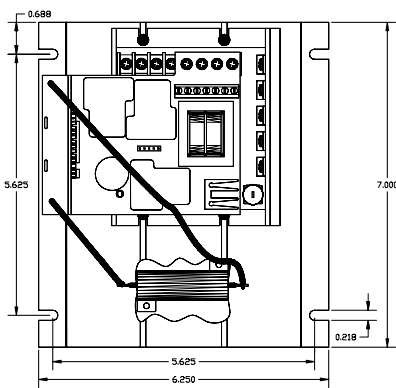

130 Series HC Models

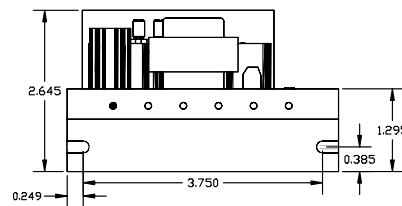
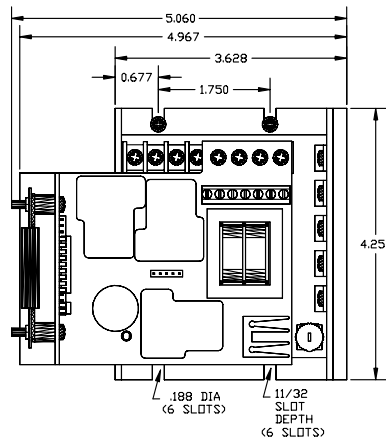

130 Series LC Models

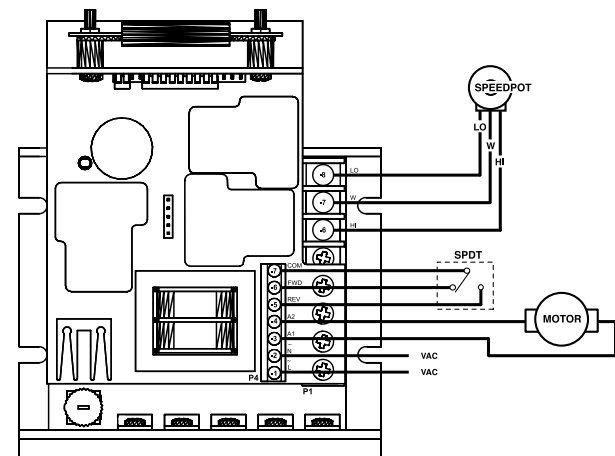

130 Series Hook-up

All dimensions in inches