



Explosion-Proof Remotely Selectable Electronic Siren

Model SSTX3-MV

DESIGNED FOR USE IN EXPLOSION-PROOF ENVIRONMENTS

- Multi-voltage design – accepts 24VDC, 120VAC or 240VAC
- Produces three tones – wail, yelp and horn
- Produces 101-108dBa @ 10'
- NEMA 4X, IP66 Approved
- UL Listed and cUL Listed

Federal Signal's SSTX3-MV is an explosion-proof electronic siren capable of producing three high decibel tones from the same unit. The integrated circuitry is contained in a rugged die cast aluminum housing. The unique threaded rear access cover eliminates traditional time consuming bolting patterns. The access cover is also equipped with a braided cable lanyard securing it to the housing whenever the cover is open for installation or maintenance.

The Model SSTX3-MV features internal amplification and tone circuitry capable of reproducing three tones. The user activates each tone (wail, yelp or horn) with dry contacts from a remote point.

This unit operates on 24VDC, 120VAC or 240VAC. It is capable of producing 108dBa @ 10 feet (118dBa @ 1m).

This electronic siren is UL and cUL Listed for Class I, Division 1, Groups B, C & D.

The Model SSTX3-MV can be used as a stand-alone, full output, audible warning device in any explosion-proof environment where multiple tones are needed but voice paging is not required.

Typical uses include emergency warning, start and dismissal, general alarm and evacuation.

Federal Signal's Model SSTX3-MV Explosion-Proof Electronic Siren is an economical multi-tone siren that is designed to hold up to the rigors of explosive and corrosive environments.

Model	Voltage	Operating Current	Decibels @	
			Tone	10' 1m
SSTX3-MV	24VDC	600mA	Wail	108 118
SSTX3-MV	120VAC	210mA	Yelp	108 118
SSTX3-MV	240VAC	120mA	Horn	101 111



EXPLOSION-PROOF ELECTRONIC SIREN (SSTX3-MV)

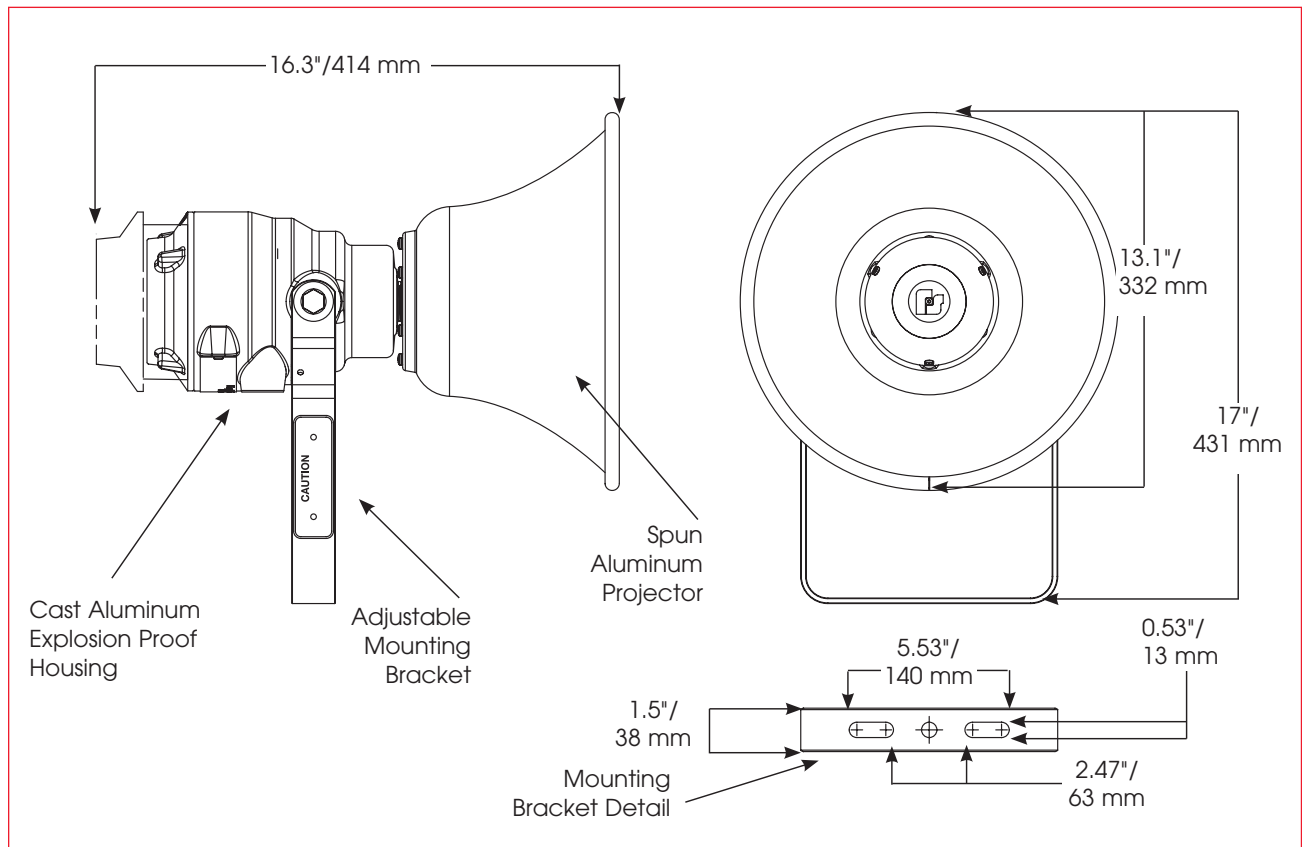

SPECIFICATIONS

Operating Temperature:	-31°F to 161°F	-35°C to 72°C
Net Weight:	15.4 lbs.	7.0 kg
Shipping Weight:	22.8 lbs.	7.4 kg
Height:	17.0"	431.80 mm
Width:	13.1"	332.73 mm
Depth:	16.3"	414.02 mm
Maximum contact resistance	1000 ohms	1000 ohms

HOW TO ORDER

- Specify model number
- Please refer to Model Number Index SSTX3-MV beginning on page 375

REPLACEMENT PARTS

<i>Description</i>	<i>Part Number</i>
PCB Assembly	K2005110A
Connector, 4-Position	K140340B
Projector Assembly	K8593100A
Driver Assembly	K8593097A