

031619

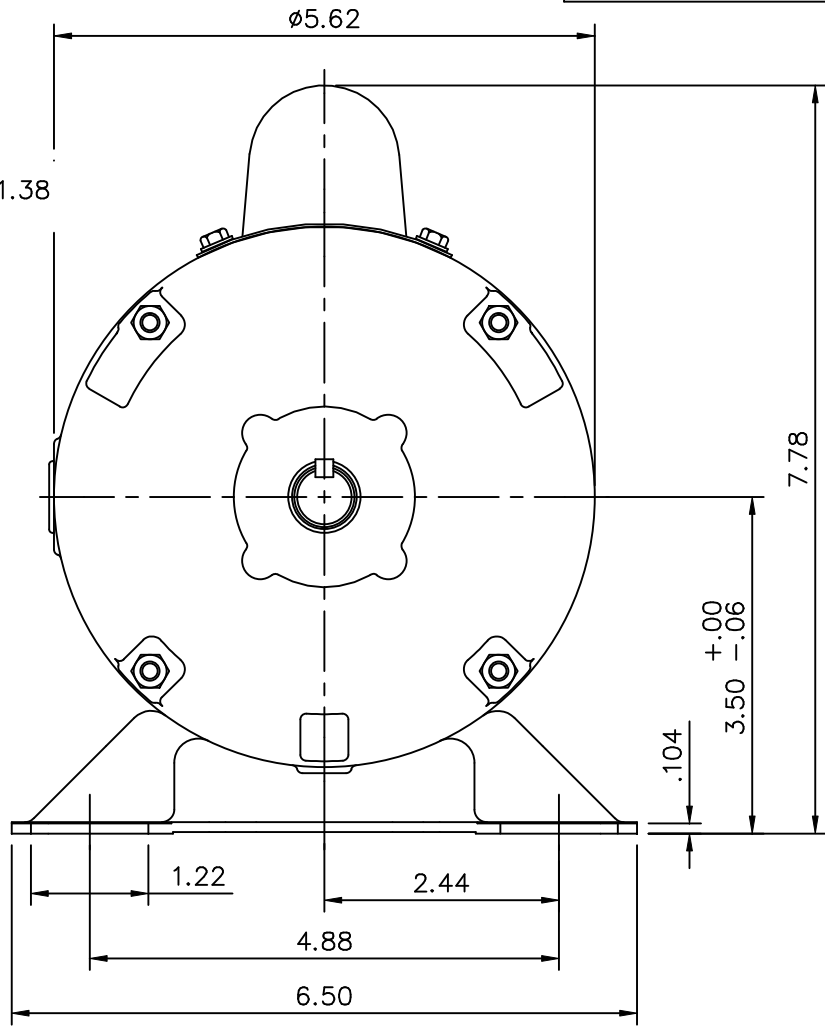
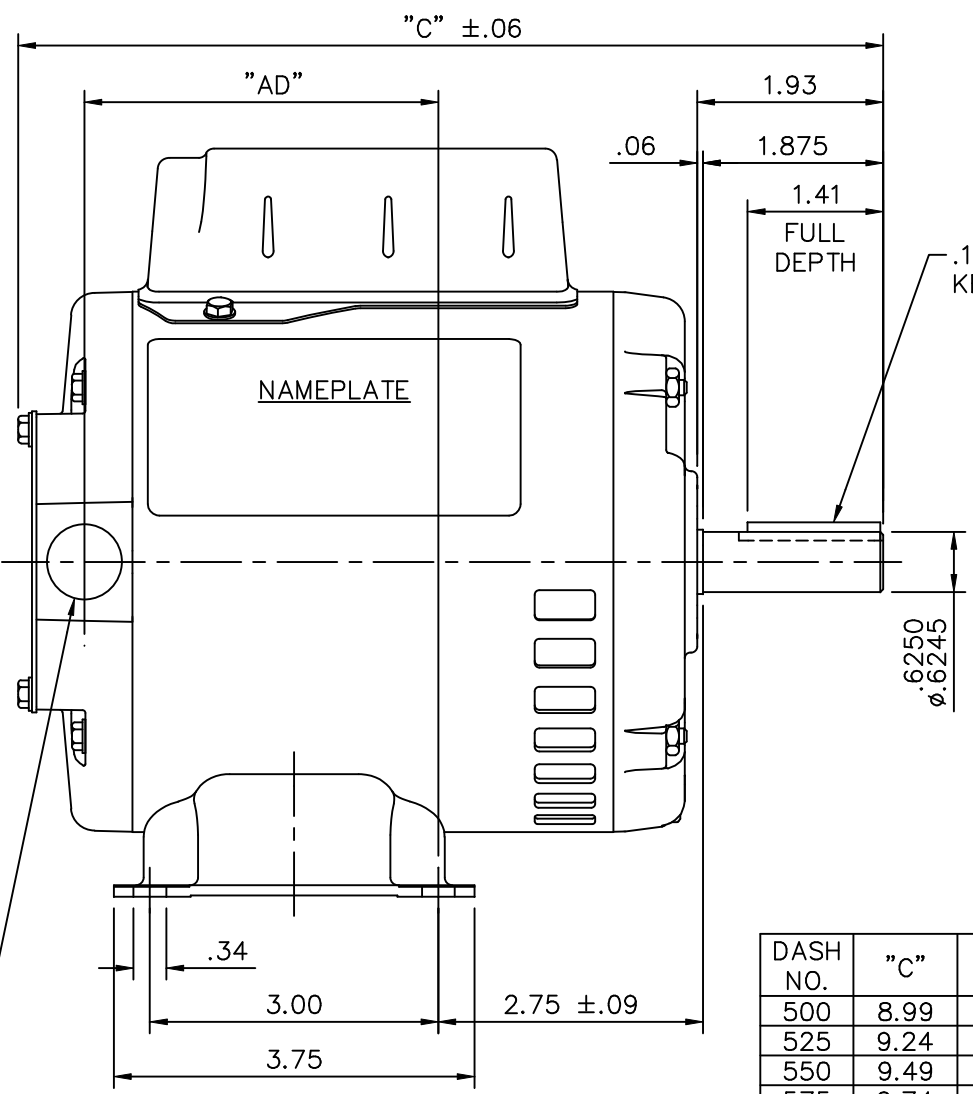

DASH NO.	"C"	"AD"
500	8.99	3.68
525	9.24	3.93
550	9.49	4.18
575	9.74	4.43
600	9.99	4.68
625	10.24	4.93
650	10.49	5.18
675	10.74	5.43

1/2-14 NPT  
CONDUIT HOLE  
(PLUGGED)

			TOLERANCES UNLESS OTHERWISE SPECIFIED			<b>LEESON</b> ELECTRIC CORPORATION				
			DEC.	INCHES	METRIC					
			.X	±.1	±2.5	DRAWN PG 5/24/01	TITLE OUTLINE - S56 FRAME			
			.XX	±.03	±.76	APPR.	RIGID MOUNT - DRIP PROOF			
			.XXX	±.005	±.127	R.F.P.	MAT'L. 1 PHASE			
NO.	REVISION	BY & DATE	CH'K'D.	.XXXX	±.0005	±.0127	SCALE 1=2			
THIS DRAWING IN DESIGN AND DETAIL IS OUR PROPERTY AND MUST NOT BE USED EXCEPT IN CONNECTION WITH OUR WORK ALL RIGHTS OF DESIGN AND INVENTION ARE RESERVED THIS IS AN ELECTRONICALLY GENERATED DOCUMENT - DO NOT SCALE THIS PRINT						FRACTIONS ±1/64	REF. 031067	FINISH	REV.	DRAWING NO. 031619
						ANGLES ±1/2'	FMF 100006			