

SS68446LE

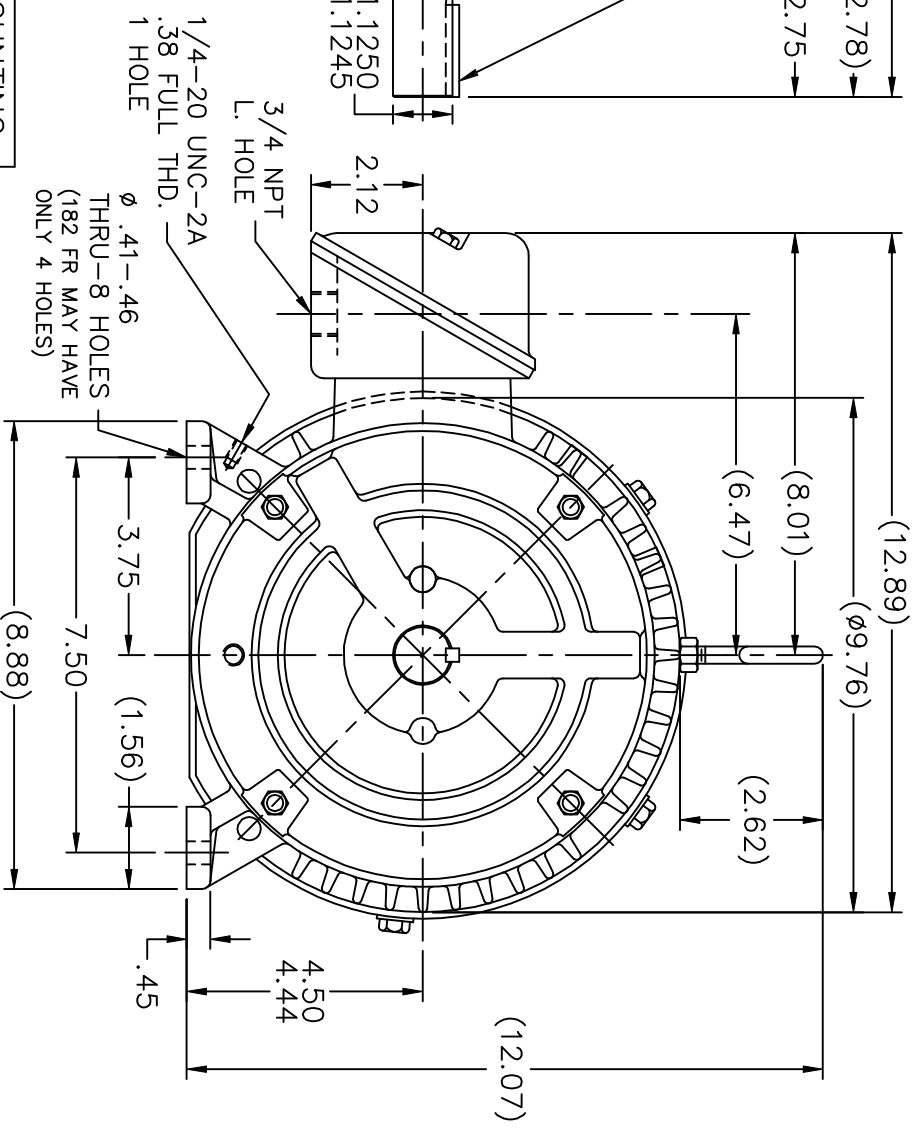
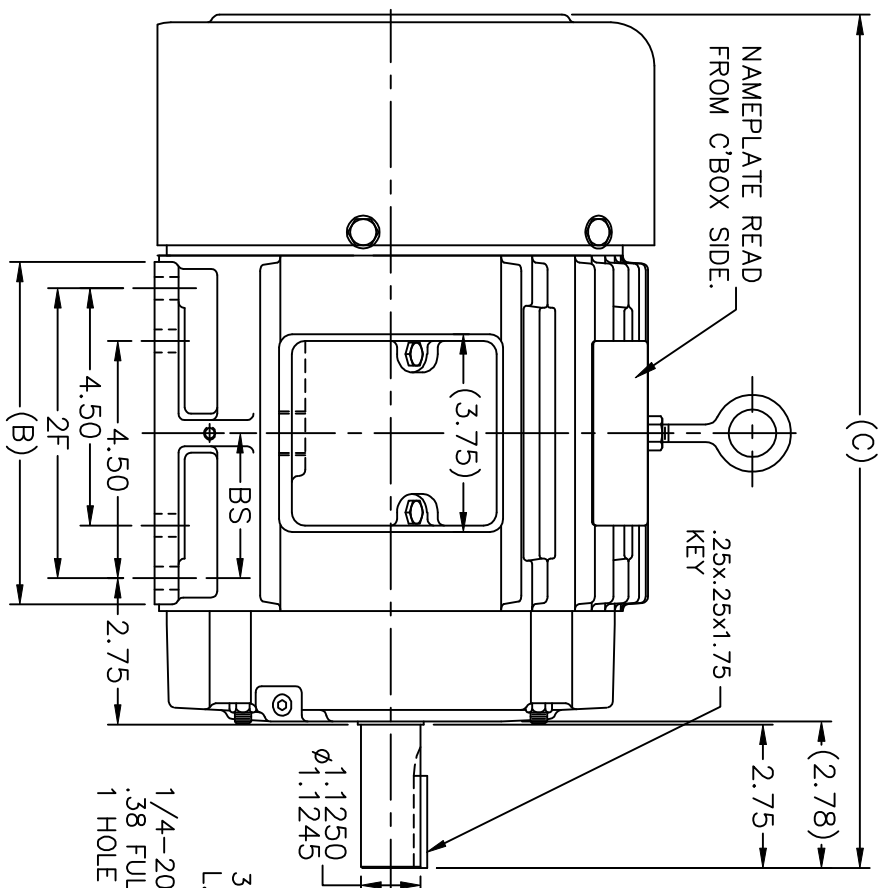

DASH	FR.	C	B	2F	BS	MOUNTING
575	182T	15.19	5.50	4.50	2.25	F1 ONLY
675	182T	16.19	6.50	5.50	2.75	F1 ONLY
675	184T	16.19	6.50	5.50	2.75	F1 OR F2

BOX CAN BE MOUNTED ON OPPOSITE SIDE BY REMOVING BRACKETS & TURNING FRAME 180°. BOX CAN BE ROTATED IN 90° STEPS.

TOLERANCES UNLESS SPECIFIED

DEC.	INCHES
X	±.1
.XX	±.03
.XXX	±.005
.XXXX	±.0005
CHK	ANG
	±7'30"



ELECTRIC MOTORS  
GEARMOTORS  
AND DRIVES

NO.	REVISION	BY & DATE	FINISH	DRAWN	PGK	07-29-1997
				CHK	ML	08-07-1997
				APPD	PH	08-11-1997
				SCALE		9=32
				REF		SS68446
				FMF		
				PREV		

NO.	REVISION	BY & DATE	CHK	ANG	RFP	DIST	LB

CAD FILE	SS68446LE	SIZE	DRAWING NO.	PAGE	OF	REV.
		A	SS68446LE			

THIS DRAWING IN DESIGN AND DETAIL IS OUR PROPERTY AND MUST NOT BE USED EXCEPT IN CONNECTION WITH OUR WORK. ALL RIGHTS OF DESIGN AND INVENTION ARE RESERVED. THIS IS AN ELECTRONICALLY GENERATED DOCUMENT - DO NOT SCALE THIS PRINT.