

MAXIMUM FACE RUNOUT TO BE .004 T.I.R.
 MAXIMUM PILOT ECCENTRICITY TO BE .004 T.I.R.
 PERMISSIBLE SHAFT RUNOUT TO BE .002 T.I.R.
 GASKETS THROUGHOUT

DASH NO.	"C"	"AD"
850	13.94	7.87
900	14.44	8.37
950	14.94	8.87
1000	15.44	9.37
1050	15.94	9.87
1100	16.44	10.37

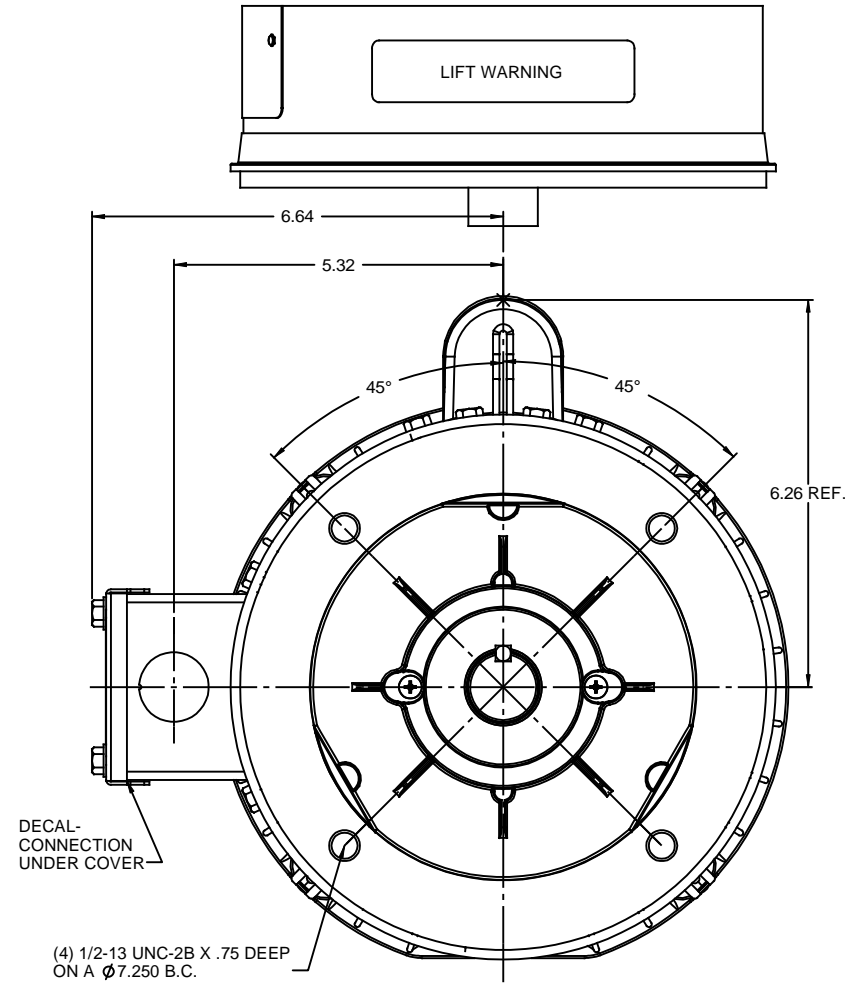
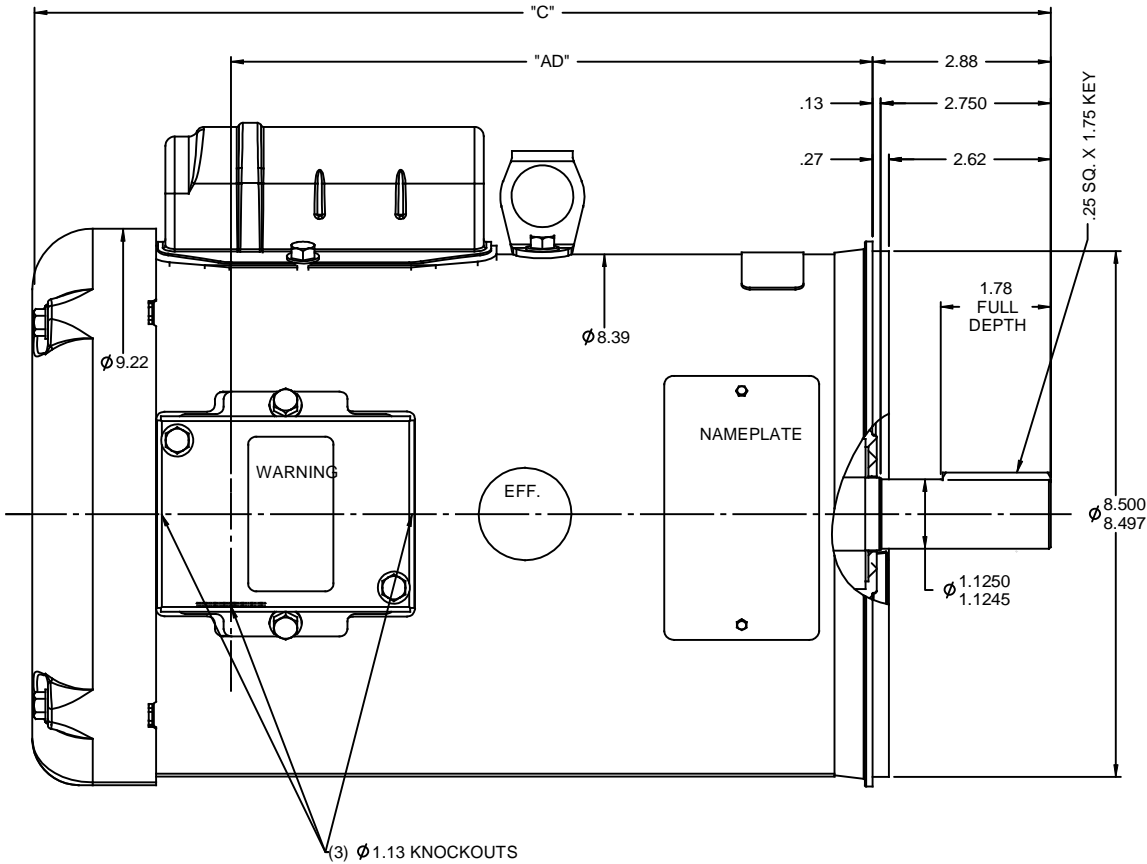

REVISION		BY & DATE	CHK	ANG	±1/2°	FINISH	PREV	SIZE	DRAWING NO	REV
NO								B	035714	

TOLERANCES UNLESS SPECIFIED		DRAWN LST 2/13/09	
DEC	INCHES	CHK	
x	±.1	APPR	
.xx	±.03	SCALE 1:2	
.xxx	±.005	REF	
.xxxx	±.0005	FMF	
NO		PAGE OF	

TITLE		REGAL-BELOIT CORPORATION	
OUTLINE 180TC FRAME		CHK	
TEFC - "C" FACE		APPR	
MAT'L		SCALE 1:2	
FINISH		REF	
PREV		FMF	
NETWORK FILE NAME		PAGE OF	

THIRD ANGLE PROJECTION