

RBC PROPRIETARY AND CONFIDENTIAL INFORMATION
 This document is the property of REGAL BELOIT CORPORATION ("RBC") including its subsidiaries and divisions and contains proprietary information of RBC. This document is loaned on the express condition that neither it nor the information contained therein shall be disclosed to others without the express written consent of RBC, and that the information shall be used by the recipient only as approved expressly by RBC. This document shall be returned to RBC upon its request. This document may be subject to certain restrictions under U.S. export control laws and regulations.

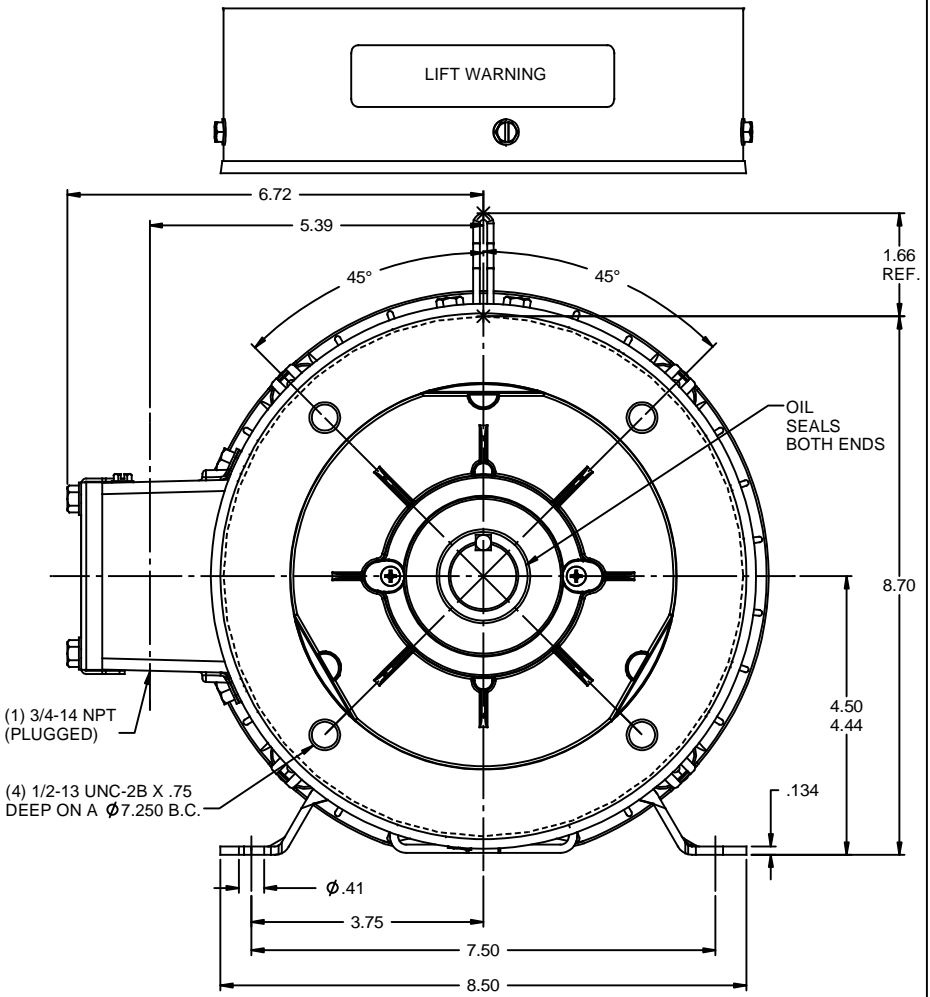
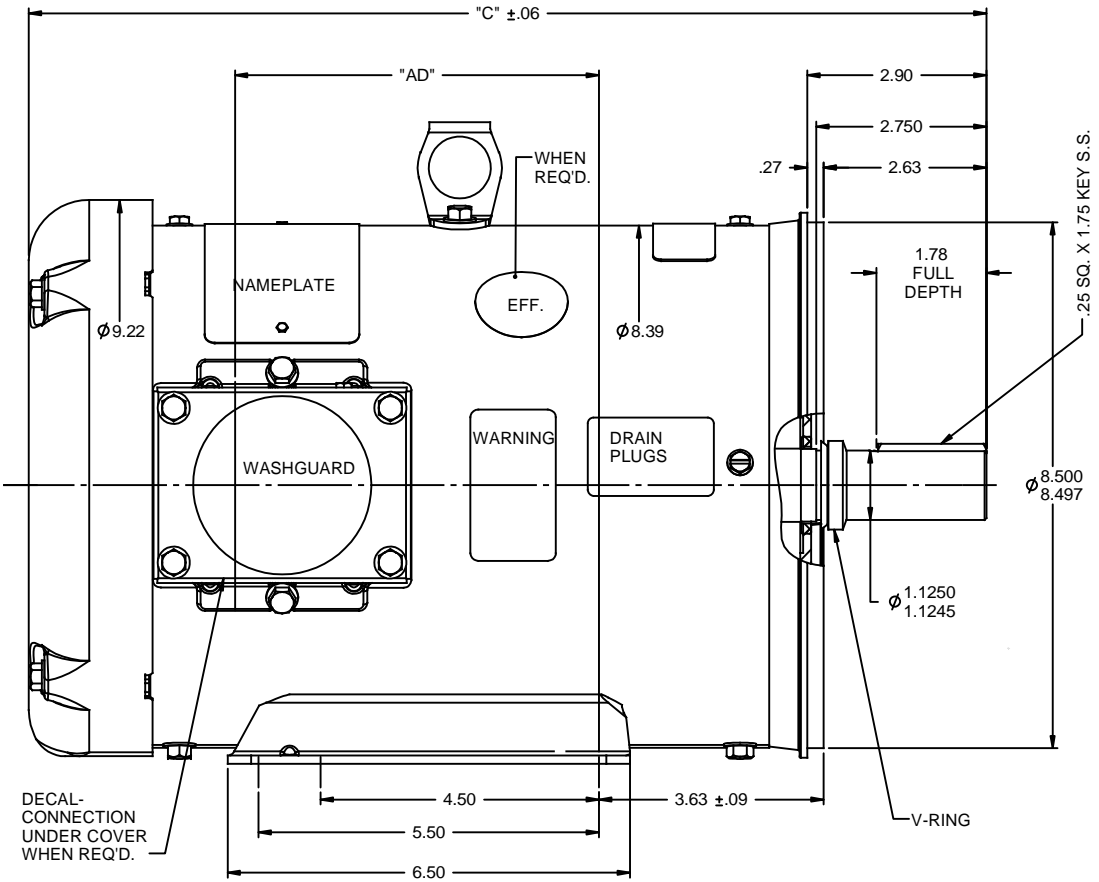

SPECIAL FEATURES:
 SHAFT SEALS & V-RING
 DRAIN HOLES IN FRAME & CONDUIT BOX
 STAINLESS STEEL SHAFT, HARDWARE & NAMEPLATE
 GASKETS THROUGHOUT

MAXIMUM FACE RUNOUT TO BE .004 T.I.R.
 MAXIMUM PILOT ECCENTRICITY TO BE .004 T.I.R.
 PERMISSIBLE SHAFT RUNOUT TO BE .002 T.I.R.

DASH NO.	"C"	"AD"
900	14.47	4.87
950	14.97	5.37
1000	15.47	5.87
1050	15.97	6.37
1100	16.47	6.87
1150	16.97	7.37

				TOLERANCES UNLESS SPECIFIED		DRAWN RDW 2/19/03	
				DEC	INCHES	CHK	
				x	±.1	APPR SW 2/19/03	
04	UPDATED PER ISAAC 11-0758	LST 2/17/2011	XX	XX	±.03	TITLE OUTLINE - 180TC FRAME	
03	UPDATED PER ISAAC 10-0580	LST 5/12/2010	XX	XXX	±.005	SCALE 1:2	
-	UPDATED & REDRAWN IN SOLIDWORKS	LST 11/17/2008	XX	XXXX	±.0005	REF	
NO	REVISION	BY & DATE	CHK	ANG	±1/2°	FINISH MATL WASHGUARD	
			RFP		PREV	PAGE OF	
THIRD ANGLE PROJECTION			NETWORK FILE NAME 035462			SIZE B	DRAWING NO 035462
							REV 04