

RBC PROPRIETARY AND CONFIDENTIAL INFORMATION

This document is the property of REGAL BELOIT CORPORATION ("RBC") including its subsidiaries and divisions and contains proprietary information of RBC. This document is loaned on the express condition that neither it nor the information contained therein shall be disclosed to others without the express written consent of RBC, and that the information shall be used by the recipient only as approved expressly by RBC. This document shall be returned to RBC upon its request. This document may be subject to certain restrictions under U.S. export control laws and regulations.

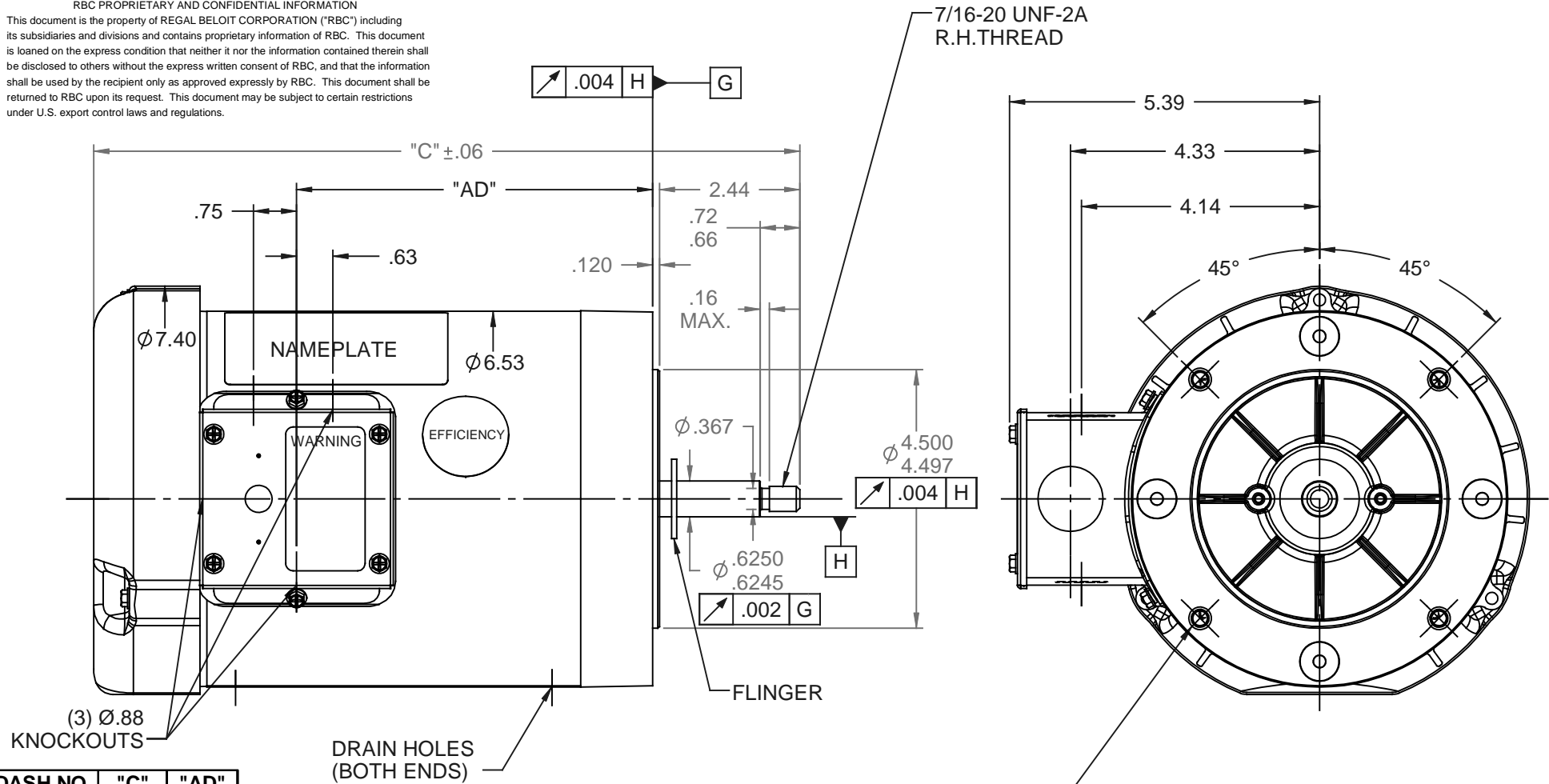

| DASH NO. | "C" | "AD" |
|----------|-------|------|
| 700 | 12.78 | 6.69 |
| 650 | 12.28 | 6.19 |
| 600 | 11.78 | 5.69 |
| 550 | 11.28 | 5.19 |
| 500 | 10.78 | 4.69 |
| 450 | 10.28 | 4.19 |

DRAIN HOLES (BOTH ENDS)

- NOTES:
 1) GASKETS THROUGHOUT
 2) FLINGER ON SHAFT
 3) STAINLESS STEEL SHAFT EXTENSION

| | | | | TOLERANCES UNLESS SPECIFIED | | ELECTRIC MOTORS GEARMOTORS AND DRIVES | DRAWN GRB 07/02/2008 | |
|------------------------|---|--------------|-----|-----------------------------|--------|---|---|---------------|
| | | | | DEC | INCHES | | CHK DJ 07/02/2008 | APPR |
| | | | | .X | ±.1 | | TITLE OUTLINE - 56 FRAME T.E.F.C. - "C" FACE | SCALE 3:8 |
| | | | | .XX | ±.03 | | | REF 028544 |
| | | | | .XXX | ±.005 | | | FMF 114206.00 |
| 01 | REMOVED DRAIN HOLE SCREWS PER ISAAC 08-3489 | LST 8/4/2008 | XX | .XXXX | ±.0005 | MAT'L JET PUMP | PAGE OF | |
| NO | REVISION | BY & DATE | CHK | ANG | ±1/2° | FINISH | | |
| THIRD ANGLE PROJECTION | | | RFP | PREV | | SIZE A | DRAWING NO 028841 | REV 01 |
| | | | | NETWORK FILE NAME | | | | |