

Complete Motor Protection	2
<i>Overload Relays</i>	2
(777-P2, 777-xxx-P2, 777-TS, 777-FT, 777VA-xx, 77C)	
<i>Power Monitors</i>	6
(777-KW/HP-P2, 777-AccuPower)	
<i>Communication Modules</i>	10
(RS485MS-2W, COM 4-20mA, CIO-DN-P, CIO-777-PR, CIO-MB, CIO-EN, Adapters)	
<i>Remote Monitoring Devices</i>	13
(RM-1000, RM-2000)	
<i>Solutions Software</i>	15
(Solutions-M, Solutions-D)	
Ground Fault Monitor	16
(601CS-D-P1, CIO-601CS-DN-P1)	
3-phase Voltage Monitors	17
(80, 102A, 201A, 201A-AU, 201-DPDT, 202, 250A, 350, 355, 455, Informer-MS, 460, 601)	
Single-phase Voltage Monitors	31
(50R, 201-xxx-SP, 201-xxx-SP-DPDT, 202-200-SP, 460-xxx-SP)	
Current Monitors (3-phase)	37
(520CS, 520CP)	
Pump Controllers	40
<i>Controllers</i>	41
(PC-102, PC-105)	
<i>Liquid Level Controls</i>	43
(PC-xxx-LLC-CZ/GM, 460-15-100-LLS)	
<i>Seal Leak Detectors</i>	45
(460-15-100-SLD, 201-100-SLD)	
<i>Alternating Duplex Pump</i>	47
(ALT-xxx-S, ALT-xxx-X, ALT-xxx-1-SW, ALT-xxx-3-SW, 50R-400-ALT)	
<i>Alarm Control/Battery Charger</i>	50
(ACBC-120)	
Intrinsically Safe Relays/Controllers	51
(ISS-100, ISS-101, ISS-102, ISS-105)	
Single-Phase PumpSavers	55
Now in a separate catalog (See Table of Contents for that catalog on page 55)	
Load Sensors	56
(LSR-0, LSR-24, LSR-115, LSR-230, LSRU, LSRX, LSRX-C)	
Auxiliary Products	61
(T10, CP-5, Current Transformers, Enclosures, Megger, Kits, Octal Sockets)	
Appendix A: Dimensional Drawings	66
Appendix B: Typical Wiring Diagrams	71
Index	IBC
Terms and Conditions	IBC

Overload Relays

Monitoring, control, and protection are critical and necessary functions in motor and pumping applications. SymCom's single-phase and three-phase UL listed enhanced overload relays monitor for both line-side voltage problems and load-side current faults, providing an added layer of protection over voltage monitors and other basic overload relays. All SymCom overload relays are user configurable and cover a wide range of voltages and currents, making them the most versatile in the industry. A standard feature of the entire family of SymCom overload relays is a communications port which provides easy connectivity to a SCADA system, PLC, or virtually any network through the use of a communications module. The communications port allows remote monitoring of motor operations and fault conditions through easy connectivity to SymCom's Remote Monitors, aiding compliance with arc flash safety regulations.

Complete Motor Protection

Product Selection Matrix

MODEL	High Voltage	Low Voltage	Phase Loss	Phase Reversal	Voltage Unbalance	Contact Failure	Low Current Trip	Low Power Trip	High Power Trip	Overcurrent Trip	Linear Overcurrent Trip (Trip Class)	Current Unbalance	Subtrol High Temp. Trip*	10-800A with CTs	1-9 Amps without external CTs	2-800 Amps without external CTs	100-240 VAC	200-480 VAC	340-480 VAC	500-600 VAC	277V Relay	600V Relay	Use with rotary phase converter
777-P2							**	**															
777 (replaced by 777-P2)							**	**															
777-P (replaced by 777-P2)							**	**															
777-P1 (replaced by 777-P2)							**	**															
777-LR-P2							**	**															
777-LR-P (replaced by 777-LR-P2)							**	**															
777-LR (replaced by 777-LR-P2)							**	**															
777-HVR-LR-P2							**	**															
777-HVR-LR (replaced by 777-HVR-LR-P2)							**	**															
777-HVR-P2							**	**															
777-HVR (replaced by 777-HVR-P2)							**	**															
777-MV-P2							**	**															
777-MV (replaced by 777-MV-P2)							**	**															
777-575-P2							**	**															
777-575 (replaced by 777-575-P2)							**	**															
777-575-P (replaced by 777-575-P2)							**	**															
777-575-P1 (replaced by 777-575-P2)							**	**															
777-575-FT (replaced by 777-575-P2)							**	**															
777-575-LR-P2							**	**															
777-575-LR (replaced by 777-575-LR-P2)							**	**															
777-HRG-P2							**	**															
777-LR-HRG-P2							**	**															
777-575-HRG-P2							**	**															
777-575-LR-HRG-P2							**	**															
777-FT																							
777-575-FT																							
777-TS																							
777-LR-TS																							
777-575-TS																							
777VA-02							**	**															
777VA-03							**	**															
77C																							
77C-LR																							
777-HVR-SP																							

* Subtrol is a registered trademark of Franklin Electric Co., Inc.
 ** Network programmable ONLY



The Model 777 / 77C



is a fully programmable electronic overload relay designed to protect any motor drawing 2-800 full load amps (external CTs are required above 90 amps). The 77C (family of products) is for single-phase 100-240VAC applications and the 777 (family of products) is for 3-phase 200-480VAC applications, with several specialized units for other voltage ranges and unique applications. Common applications include conveyer systems, HVAC equipment, saws and grinders, fan motors, and almost any pumping application. Some unique applications include use with a Subtrol® equipped Franklin submersible motor to detect high motor temperatures and applications where a fast linear trip is required.

All of the overload relays provide unsurpassed protection by combining overload, underload, voltage and power monitoring functions in one package. The overload relays have a 3-digit display for viewing real-time voltage and current and for displaying the last or active fault code (to simplify diagnostics) when tripped for a fault condition. The units can be used as a stand-alone product or the communications port can be used to form a Modbus, DeviceNet™, Profibus, or Ethernet network to monitor up to 99 units from a PC, PLC, or SCADA system, and for data logging through a PC with SymCom's Solutions software (see page 15).

The communications port can also be used for remote monitoring (see SymCom's remote monitors on page 13) to improve safety for personnel by allowing them to monitor and control motor operation without opening the electrical cabinet. This capability allows for a simple, cost-effective way to meet new requirements for arc-flash safety.

For more information see:
See Appendix A, page 66, Figure 1 for dimensional drawing.
See Appendix B, page 71, Figures 1-4 for typical wiring diagrams.

Features:

- Built-in 3-digit display for programming, real-time info, and diagnostics
- Programmable voltage and current settings/parameters
- Programmable restart control (automatic, semi-automatic, or manual)
- 3 separate programmable restart delay timers (rapid-cycle protection, motor cool down and dry-well recovery)
- Run-hour meter (available via network or remote displays)
- Reset pushbutton (and optional remote reset pushbutton)
- Current/last fault indication on 3-digit display
- Last four faults (with characteristics) available via network or remote displays
- Network communications (Modbus, DeviceNet™, Profibus, or Ethernet)
- Optional remote displays aid compliance with arc-flash safety regulations
- Approvals:   

Auxiliary Products:

- Communication Modules (see pgs. 10-12)
- RM-1000/RM-2000 (remote displays) (see pgs. 13-14)
- Solutions Software (see pg. 15)
- Manual Remote Reset Kit (see pg. 65)

Available Models:

77C
77C-LR
777-HVR-SP
777-P2
777-LR-P2
777-HVR-P2
777-HVR-LR-P2
777-575-P2
777-MV-P2
777-575-LR-P2
777-HRG-P2
777-LR-HRG-P2
777-575-HRG-P2
777-575-LR-HRG-P2
777-FT
777-575-FT
777-TS
777-LR-TS
777-575-TS
777VA-02
777VA-03

DEMOS:

777-P2-DEMO (777-P2 Demo only)
777-P2-DEMO-1 (777-P2 demo with CIO-EN Ethernet Module)
777-P2-DEMO-2 (777-P2 demo, CIO-EN and RM-1000 Remote Monitor)
777-P2-DEMO-3 (777-P2 demo, CIO-EN, RM-1000 and RM-2000 Remote Monitors)

Specifications

Input Characteristics

Line Voltage

777-P2, 777-LR-P2, 777-HRG-P2	200-480VAC
777-TS, 777-LR-TS, 777-LR-HRG-P2	200-480VAC
777VA-02, 777VA-03	200-480VAC
77C, 77C-LR, 777-MV-P2	100-240VAC
777-HVR-P2, 777-HVR-LR-P2, 777-HVR-SP	340-480VAC
777-575-P2, 777-575-LR-P2, 777-575-HRG-P2	500-600VAC
777-575-TS, 777-575-LR-HRG-P2	500-600VAC

Frequency 50/60Hz

Motor Full Load Amp Range

77C-LR, 777-LR-TS	1-9A
777-LR-P2, 777-575-LR-P2, 777-HVR-LR-P2	1-9A & 10-800A with external CTs
777-LR-HRG-P2, 777-575-LR-HRG-P2	10-800A (external CTs required, external zero-seq. CT required)
777-HRG-P2, 777-575-HRG-P2	2-90A only
777-MV-P2	10-800A with CTs
77C, 777-P2, 777-575-P2	2-800A (external CTs required above 90A)
777-HVR-P2	2-800A (external CTs required above 90A)
777-TS, 777-575-TS, 777VA-02	2-800A (external CTs required above 90A)
777VA-03, 777-HVR-SP	2-800A (external CTs required above 90A)

Functional Characteristics

TC- Overcurrent Trip Class (777 Plus Series units) 02-60, J02-J60, L00-L60 or Off

TC- Overcurrent Trip Class (77C, 777 non-Plus Series units) 5, 10, 15, 20, 30 (J prefix enables jam protection feature)

Output Characteristics

Output Contact Rating (SPDT - Form C)

Pilot duty rating	480VA @ 240VAC, B300
General purpose	10A @ 240VAC
Pilot duty rating for HVR models	470VA @ 600VAC, B600

General Characteristics

Ambient Temperature Range

Operating	-20° to 70°C (-4° to 158°F)
Storage	-40° to 80°C (-40° to 176°F)

Accuracy

Voltage	±1%
Current	±3% (<100 amps direct)
GF Current	±15%
Timing (777 Plus Series units)	±0.5 second
Timing (77C, 777 non-Plus Series units)	5% ±1 second

Repeatability

Voltage	±0.5% of nominal voltage
Current	±1% (<100 amps direct)

Maximum Input Power 10 W

Pollution Degree 3

Class of Protection IP20

Relative Humidity 10-95%, non-condensing per IEC 68-2-3

Terminal Torque 7 in.lbs.

Standards Passed

Electrostatic Discharge (ESD)	IEC 61000-4-2, Level 3, 6kV contact, 8kV air
Radio Frequency Immunity (RFI), Conducted	IEC 61000-4-6, Level 3 10V/m
Radio Frequency Immunity (RFI), Radiated	IEC 61000-4-3, Level 3 10V/m
Fast Transient Burst	IEC 61000-4-4, Level 3, 3.5kV input power

Short Circuit 100kA

Surge

IEC	61000-4-5, Level 3, 2kV line-to-line; Level 4, 4kV line-to-ground
ANSI/IEEE	C62.41 Surge and Ring Wave Compliance to a level of 6kV line-to-line

Hi-potential Test Meets UL508 (2 x rated V +1000V for 1 minute)

Vibration IEC 68-2-6, 10-55Hz, 1mm peak-to-peak, 2 hours, 3 axis

Shock IEC 68-2-27, 30g, 3 axis, 11ms duration, half-sine pulse

Safety Marks

UL	UL508, UL1053 (File #E68520)
CE	IEC 60947-1, IEC 60947-5-1
CSA	C22.2

Maximum Conductor Size (with insulation) through 777/77C 0.65"

Dimensions 3.05 H x 3.85 W x 5.05 D in. (77.47 x 97.79 x 128.27 mm)

Weight 1.56 lbs. (24.96 oz., 707.6 g)

Mounting Method Surface mount (4 - #8 screws) or DIN rail mount

-P2 The 777-P2 protects 200-480VAC, 2-800 full load amp (FLA) motors and provides protection from overvoltage and undervoltage, overcurrent and undercurrent and unbalanced voltage or unbalanced current through adjustable setpoints. Provides adjustable Trip Class (TC) settings that include settings from 2-60, with or without “jam” protection, and linear TC from <1 second to 60 seconds. The fast linear TC is ideal for applications where very short trip delays are needed to prevent chain drives and other drive linkages from breaking in an overload or jam situation (ex. sewage clarifiers, mixers, augers, conveyors). This family of products also includes network programmable alarm setpoints and high and low power trip points (programmable through a network or SymCom’s Solutions Software).

-LR (Low Range) The 777-LR-P2 is specifically designed for use with 1-9 FLA motors to ease installation when wired directly, or for 10-800 FLA motors with use of external CTs.

-HVR The 777-HVR-P2 or 777-HVR-LR-P2 is required when a CPT (control power transformer) is not used on a 480V system. They have a 340-480VAC range, a relay rated at 470VA @ 600VAC pilot duty, and is commonly used in pumping applications to save the cost and extra wiring associated with a CPT.

-HRG The 777-HRG-P2 / 777-LR-HRG-P2 are overload relays, designed for a high resistance ground system, that incorporates an internal zero-sequence CT (HRG) or an external zero-sequence CT (LR-HRG) to detect ground faults. The HRG is only for 2-90 FLA and is wired directly. The LR-HRG is only for 10-800 FLA and requires the use of external CTs that correspond with the built-in multipliers.

-MV The 777-MV-P2 is specifically designed for medium voltage applications where both PTs (potential transformers) and CTs (current transformers) are used. It has a 115-230VAC nominal voltage range and built-in multipliers for 25:5, 50:5, 100:5, ...CTs. The voltage unbalance, single-phase and reverse-phase protection can be disabled to accommodate applications where only one PT is used.

-575 The 777-575-P2 has a nominal 500-600VAC range and 240V relay. They are commonly used in Canada and the Northeast US where 575V utility power services are common.

-VA-02 The 777VA-02 has RD1 setpoints of 2-500 minutes and UCTD setpoints of 2-60 minutes. (Replaced 777-RD1M-UCTDM).

-VA-03 The 777VA-03 is specifically designed for use with static and rotary single to 3-phase converters. Voltage unbalance protection is disabled and the high and low voltage trip features apply only to the utility supplied power. This allows the 777 to ignore the severely unbalanced voltages that are inherent to unloaded phase converters. (Replaced 777-PH.)

-SP The 777-HVR-SP is specifically designed for single-phase, 480VAC applications. It has a high voltage relay rated at 480VA @ 600VAC pilot duty to handle systems with no control power transformer.

-FT The 777-FT is intended for applications where a fast linear trip is required. It has an overcurrent trip delay that can be set to less than 500ms, to be used in applications where very short trip delays are needed to prevent chain drives and other drive linkages from breaking in an overload or jam situation. Often times these are referred to as shock relays. Some applications include sewage clarifiers, mixers, augers and conveyors. The trip delay can be set to as long as 70 seconds, so the 777-FT can also be used in certain applications when a slower than normal trip is desired, such as motor test panels in a rewind shop. The 777-FT also features an adjustable motor acceleration time and overcurrent trip delay time when using the fast linear trip mode.

-TS The 777-TS is specifically designed for use with a Subtrol[®]-equipped Franklin submersible motor to detect high motor temperatures.

-DEMO SymCom offers demo packages for the Model 777 family and remote monitors. These demos are powered via one power adapter (included) and are very easy to set up for use as sales tools or for training purposes. Four packages of the MotorSaver[®] and four of the PumpSaver[®] versions are available ranging from the basic model 777 up to a complete package including the Ethernet module and both remote monitors. Which package to choose will depend on your markets and/or product focus.)

Power Monitors

Many pumping applications require advanced power monitoring and control. SymCom enhanced power monitors provide all of the protections and features included with an enhanced overload relay, but are designed specifically for applications where there is not much change in current between a load and no load condition. This family of enhanced power monitors provides optimum protection in these adverse situations by monitoring for subtle changes in voltage, current and power factor to distinguish between changing load conditions.

Product Selection Matrix

MODEL	High Voltage	Low Voltage	Phase Loss	Phase Reversal	Voltage Unbalance	Contactors Failure	Low Current Trip	Low Power Trip	High Power Trip	Overcurrent Trip	Linear Overcurrent Trip (Trip Class)	Current Unbalance	10-800 A with CTs	1-9 Amps	0.5-21 and 40-740 Amps w/ CTs	2-800 Amps	200-480VAC	340-480VAC	500-600VAC	277V Relay	600V Relay	Displays Output Shaft Power
777-KW/HP-P2	•	•	•	•	•	**	•	**	•	•	•	•	•	•	•	•	•	•	•	•	•	•
777-KW/HP (replaced by 777-KW/HP-P2)	•	•	•	•	•	**	•	**	•	•	•	•	•	•	•	•	•	•	•	•	•	•
777-KW/HP-P (replaced by 777-KW/HP-P2)	•	•	•	•	•	**	•	**	•	•	•	•	•	•	•	•	•	•	•	•	•	•
777-LR-KW/HP-P2	•	•	•	•	•	**	•	**	•	•	•	•	•	•	•	•	•	•	•	•	•	•
777-LR-KW/HP (replaced by 777-LR-KW/HP-P2)	•	•	•	•	•	**	•	**	•	•	•	•	•	•	•	•	•	•	•	•	•	•
777-LR-KW/HP-P (replaced by 777-LR-KW/HP-P2)	•	•	•	•	•	**	•	**	•	•	•	•	•	•	•	•	•	•	•	•	•	•
777-MLR-KW/HP-P2	•	•	•	•	•	**	•	**	•	•	•	•	•	•	•	•	•	•	•	•	•	•
777-MLR-KW/HP (replaced by 777-MLR-KW/HP-P2)	•	•	•	•	•	**	•	**	•	•	•	•	•	•	•	•	•	•	•	•	•	•
777-HVR-KW/HP-P2	•	•	•	•	•	**	•	**	•	•	•	•	•	•	•	•	•	•	•	•	•	•
777-HVR-KW/HP (replaced by 777-HVR-KW/HP-P2)	•	•	•	•	•	**	•	**	•	•	•	•	•	•	•	•	•	•	•	•	•	•
777-575-KW/HP-P2	•	•	•	•	•	**	•	**	•	•	•	•	•	•	•	•	•	•	•	•	•	•
777-575-KW/HP (replaced by 777-575-KW/HP-P2)	•	•	•	•	•	**	•	**	•	•	•	•	•	•	•	•	•	•	•	•	•	•
777-AccuPower	•	•	•	•	•	•	•	•	•	•	•	•	•	•	•	•	•	•	•	•	•	•

** Network programmable ONLY.

Power Monitors

Model 777-KW/HP-P2 Product Line

3-phase current & voltage monitor, on-board display, optional communications, underpower trip for more accurate/faster motor protection versus undercurrent trip



The Model 777-KW/HP-P2 Series

has the underload trip, adjustable on the face of the unit, based on power, while all the other products in the 777 family provide an undercurrent trip.

The underpower trip feature is desirable anytime the current vs. load characteristic is non-linear or has little change. In general terms, smaller motors and slow speed motors have little change in current over the normal load range. Larger motors that are running light loads will also show small current changes over the operating load range.

KW/HP products should be used with all small centrifugal motors and fractional horsepower motors when underload protection is needed and with most motors under 3hp. Also use KW/HP products when the motor is derated (Ex: Coal bed methane well with a 7.5hp submersible pump on a

10hp motor.) Other typical applications are mixer motors up to 50hp and beyond that run at less than 1800 rpm, magdrive pumps and can pumps. If in doubt, underpower can be used anytime in place of undercurrent protection.

The 777-KW/HP-P2 can display kilowatts and horsepower and a high power trip feature that can be enabled over a network. The high power trip is useful added protection for positive displacement pumps in a restricted flow (dead-head) condition.

-LR (Low Range) The 777-LR-KW/HP-P2 is specifically designed for use with 1-9 FLA motors to ease installation when wired directly, or for 10-800 FLA motors with use of external CTs.

-HVR The 777-HVR-KW/HP-P2 is required when a CPT (control power transformer) is not used on a 480V system. It has a 340-480VAC range, a relay rated at 470VA @ 600VAC pilot duty, and is commonly used in pumping applications to save the cost and extra wiring associated with a CPT.

-575 The 777-575-KW/HP-P2 has a nominal 500-600VAC range and 240V relay. They are commonly used in Canada and the Northeast US where 575V utility power services are common.

-MLR The 777-MLR-KW/HP-P2 is used in applications that have a 0.5-21 and 40-740 full load amp range. It is wired directly without the need to loop conductors for 5-21 amps (under 5 amps requires looping of conductors), and can be used with external CTs for 40-740 amps.

For more information see:

See Appendix A, page 66, Figure 1 for dimensional drawing.

See Appendix B, page 71, Figures 1 & 2 for typical wiring diagrams.

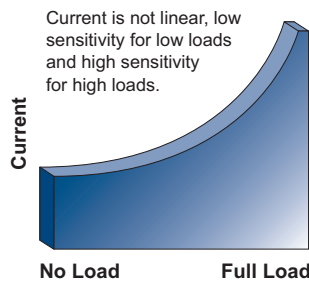
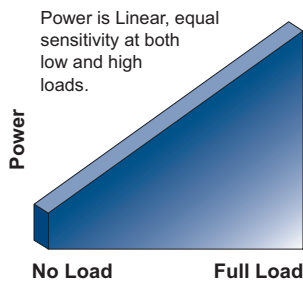

Features:

- Low power protection
- High power protection
- Overcurrent (overload)
- High voltage
- Low voltage
- Current unbalance
- Voltage unbalance
- Ground fault detection
- Modbus communication
- Built-in 3-digit display for setup and diagnostics
- Network communications

Approvals:   

Auxiliary Products:

- Communication Modules (see pgs. 10-12)
- RM-1000/RM-2000 (remote displays) (see pgs. 13-14)
- Solutions Software (see pg. 15)
- Manual Remote Reset Kit (see pg. 65)

Available Models:

777-KW/HP-P2

777-LR-KW/HP-P2

777-HVR-KW/HP-P2

777-575-KW/HP-P2

777-MLR-KW/HP-P2

DEMOS:

777-KW/HP-P2-DEMO (777-KW/HP-P2 Demo only)

777-KWHP-P2-DEMO1 (777-KW/HP-P2 demo with CIO-EN Ethernet Module)

777-KWHP-P2-DEMO2 (777-KW/HP-P2 demo, CIO-EN and RM-1000 Remote Monitor)

777-KWHP-P2-DEMO3 (777-KW/HP-P2 demo, CIO-EN, RM-1000 and RM-2000 Remote Monitor)

Specifications

Input Characteristics

Line Voltage	
777-KW/HP-P2	200-480VAC (3-phase)
777-LR-KW/HP-P2, 777-MLR-KW/HP-P2	200-480VAC (3-phase)
777-HVR-KW/HP-P2	340-480VAC (3-phase)
777-575-KW/HP-P2	500-600VAC (3-phase)

Current

777-KW/HP-P2	2-800A (external CTs required above 90A)
777-HVR-KW/HP-P2, 777-575-KW/HP-P2	2-800A (external CTs required above 90A)
777-LR-KW/HP-P2	1-9A & 10-800A with external CTs
777-MLR-KW/HP-P2	0.5-21A and 40-740A with external CTs

Frequency	50/60Hz
-----------	---------

Functional Characteristics

TC-Overcurrent Trip Class	02-60, J02-J60, L00-L60 or OFF
---------------------------	--------------------------------

Output Characteristics

Output Contact Rating (SPDT - Form C)

Pilot duty rating	480VA @ 240VAC, B300
General purpose	10A @ 240VAC
Pilot duty rating for HVR model	470VA @ 600VAC, B600

General Characteristics

Ambient Temperature Range

Operating	-20° to 70°C (-4° to 158°F)
Storage	-40° to 80°C (-40° to 176°F)

Accuracy

Voltage	±1%
Current	±3% (<100 amps direct)
Power	±4% (<100 amps direct)
GF Current	±15%
Timing	±0.5 second

Repeatability

Voltage	±0.5% of nominal voltage
Current	±1% (<100 amps direct)
Power	±2%

Maximum Input Power	10 W
---------------------	------

Pollution Degree	3
------------------	---

Class of Protection	IP20
---------------------	------

Relative Humidity	10-95%, non-condensing per IEC 68-2-3
-------------------	---------------------------------------

Terminal Torque	7 in.-lbs.
-----------------	------------

Standards Passed

Electrostatic Discharge (ESD)	IEC 61000-4-2, Level 3, 6kV contact, 8kV air
Radio Frequency Immunity (RFI), Conducted	IEC 61000-4-6, Level 3 10V/m
Radio Frequency Immunity (RFI), Radiated	IEC 61000-4-3, Level 3 10V/m
Fast Transient Burst	IEC 61000-4-4, Level 3, 3.5 kV input power

Short Circuit Rating	100kA
----------------------	-------

Surge

IEC	61000-4-5, Level 3, 2kV line-to-line; Level 4, 4kV line-to-ground
ANSI/IEEE	C62.41 Surge and Ring Wave Compliance to a level of 6kV line-to-line

Hi-potential Test	Meets UL508 (2 x rated V +1000V for 1 minute)
-------------------	---

Vibration	IEC 68-2-6, 10-55Hz, 1mm peak-to-peak, 2 hours, 3 axis
-----------	--

Shock	IEC 68-2-27, 30g, 3 axis, 11ms duration, half-sine pulse
-------	--

Safety Marks

UL	UL508, UL1053 (File #E68520)
CE	IEC 60947-1, IEC 60947-5-1
CSA	C22.2

Maximum Conductor Size (with insulation) through 777	0.65"
--	-------

Dimensions	3.05 H x 3.85 W x 5.05 D in. (77.47 x 97.79 x 128.27 mm)
------------	--

Weight	1.56 lbs. (24.96 oz., 707.6 g)
--------	--------------------------------

Mounting Method	Surface mount (4 - #8 screws) or DIN rail mount
-----------------	---

Power Monitors

3-phase current & voltage monitor, on-board display, calculates motor output power with optional 4-20mA communications

Model 777-AccuPower





The Model 777-AccuPower

is a fully-programmable 3-phase motor and pump protection relay. It allows motor hp rating, full load amps, efficiency and power factor to be entered and will accurately calculate motor output power. This is most useful with mag-drive pumps or process applications where the process power is desired over the utility power. Voltage, current and power measurements can be displayed as well as fault information and setpoints. The built-in display simplifies troubleshooting and allows the user to easily and precisely configure setpoints. The 777-AccuPower can be used with SymCom's 4-20mA output module to give an analog signal proportional to output shaft power.

For more information see:
See Appendix A, page 66, Figure 1 for dimensional drawing.
See Appendix B, page 71, Figures 1 & 2 for typical wiring diagrams.

Features:

- Motor output power measurement
- 3 separate restart timers for rapid-cycle protection, motor cool down and dry-well recovery
- Built-in 3-digit display for setup and diagnostics
- Last fault indication on display
- Last 4 faults available on network or remote displays
- Optional remote displays (RM-1000 or RM-2000) via Modbus communications
- Limited Modbus capabilities
- Adjustable underload trip delay (network only)
- Power factor measurement (network readable)
- Run-hour meter (network readable)
- 4-20mA scalable output signal

Approvals:   

Auxiliary Products:

- Com 4-20mA (for 4-20mA output)
- RS485MS-2W (for limited Modbus capabilities)
- RM-1000/RM-2000 (remote displays)

Available Models:

777-AccuPower

Specifications

Input Characteristics	
Line Voltage	200-480VAC
Frequency	50/60Hz
Motor Full Load Amp Range.....	2-800A (external CTs required over 90A)
Functional Characteristics	
TC- Overcurrent Trip Class	5, 10, 15, 20, 30 (J prefix enables jam protection feature)
Output Characteristics	
Output Contact Rating (SPDT - Form C)	
Pilot duty.....	480VA @ 240VAC
General purpose.....	10A @ 240VAC
General Characteristics	
Ambient Temperature Range	
Operating	-40° to 70°C (-40° to 158°F)
Storage.....	-40° to 80°C (-40° to 176°F)
Accuracy	
Measured Horsepower/Kilowatt	
Typical	±3%**
Voltage	±1%
Current	±3% (<100 amps direct)
GF Current.....	±15%
Timing	5% ±1 second
Repeatability	
Voltage.....	±0.5% of nominal voltage
Current.....	±1% (<100 amps direct)
Maximum Input Power.....	10 W
Pollution Degree:	3
Class of Protection:	IP20, NEMA 1 (finger safe)
Relative Humidity:	10-95%, non-condensing per IEC 68-2-3
Terminal Torque.....	.7 in.-lbs.

Standards Passed	
Electrostatic Discharge (ESD).....	IEC 61000-4-2, Level 3, 6kV contact, 8kV air
Radio Frequency Immunity (RFI), Conducted	IEC 61000-4-6, Level 3 10V/m
Radio Frequency Immunity (RFI), Radiated	IEC 61000-4-3, Level 3 10V/m
Fast Transient Burst	IEC 61000-4-4, Level 3, 3.5 kV input power
Short Circuit Rating.....	100kA
Surge	
IEC	61000-4-5 Level 3, 2kV line-to-line; Level 4, 4kV line-to-ground
ANSI/IEEE	C62.41 Surge and Ring Wave Compliance to a level of 6kV line-to-line
Hi-Potential Test	Meets UL508 (2 x rated V + 1000V for 1 min.)
Vibration	IEC 68-2-6, 10-55Hz, 1mm peak-to-peak, 2 hrs, 3 axis
Shock	IEC 68-2-27, 30g, 3 axis, 11ms duration, half-sine pulse
Safety Marks	
UL.....	UL508, UL1053
CE.....	IEC 60947-1, IEC 60947-5-1
CSA.....	C22.2
Max. conductor size thru 777.....	.065" with insulation
Dimensions	3.05 H x 3.85 W x 5.05 D in. (77.47 x 97.79 x 128.27 mm)
Weight	1.3 lbs. (20.8 oz., 589.67 g)
Mounting Method	Surface mount (4 - #8 screws) or DIN rail mount

**On a well balanced system within recommended current range.



The RS485MS-2W

is required to enable the Modbus communications function on Model 77x-type products. This module is required when the RM-1000, RM-2000 or other Modbus capable device is used with 77x-type products.

For more information see: See Appendix A, page 66, Figure 2 for dimensional drawing.

Features:

- Optical isolation from line potentials
- Powered by the 77x product
- RS-485 compliant bus drive capability
- Remote reset input connection
- Power connection for the Model RM-1000

Approvals:

Available Models:

RS485MS-2W

Specifications

Functional Specifications

Remote Reset (for use with optional 777 Series) . . . Normally open pushbutton rated 24VDC, 10mA (min.)

General Characteristics

Ambient Operating Temperature -20° to 50°C (-4° to 122°F)

Terminal (depluggable terminal block)

Torque 3 in.-lbs. (max.)

Wire AWG. 12-20 AWG

Class of Protection IP20

Relative Humidity 10-95%, non-condensing per IEC 68-2-3

Standards Passed

Electrostatic Discharge (ESD) IEC 61000-4-2, Level 3, 6kV contact, 8kV air

Radio Frequency Immunity, Radiated 150 MHz, 10V/m

Fast Transient Burst IEC 61000-4-4, Level 3, 4kV input power

Hi-Potential Test Meets UL508 (2 x rated V + 1000V for 1 min)

Surge

Input Power IEC 61000-4-5, Level 1

Inputs/Data Lines IEC 61000-4-5, Level 2

Safety Marks

UL UL508 (File #E68520)

CE IEC 60947

Enclosure Polycarbonate

Dimensions 2.08" H x 2.776" W x 0.77" D

Weight 0.26 lb. (4.16oz., 117.93 g)

Mounting Method 9-pin D-Sub connector on the side of a 777-Series



The CIO-MB / CIO-120-MB Modules

are convenient and cost-effective Modbus-RTU interfaces capable of providing discrete control and monitoring of an overload relay over a Modbus network.

For more information see: See Appendix A, page 66, Figure 3 for dimensional drawing.

Features:

- Can be used in both new and existing installations
- Can be used as stand-alone or with a 777 Plus series unit
- Can be re-configured to work with standard 777 units
- Reduced field wiring. Unpluggable terminal block connection for network.
- Ease in system startup and commissioning
- Compact size
- DIN rail or surface mountable
- Additional remote reset input to reset 777 Plus series
- Flexible addressing standard

Approvals:

Available Models:

CIO-MB

CIO-120-MB

Specifications

Functional Specifications

Remote Reset (for use with optional 777 Series) Normally open pushbutton rated 24VDC, 10mA (min.)

Power Requirements

Voltage 24VDC ±10%

Current 95mA (max.) 70mA (typical)

Power 2.28 W (max.) 1.7 W (typical)

Ethernet Controller IEEE 802.3

Capability 10Base-T

Input Characteristics

General Purpose (4)

Voltage Range

CIO-MB 12-24VDC

CIO-120-MB 90-130VAC

Current 2mA (typical)

Output Characteristics

SPDT (1), SPST (1)

Pilot Duty 480VA & 240VAC, B300

General Purpose 5A @ 240VAC

General Characteristics

Ambient Operating Temperature -20° to 70°C (-4° to 158°F)

Terminal (depluggable terminal block)

Torque 3 in.-lbs. (max.)

Wire AWG. 12-20 AWG

Class of Protection IP20, NEMA 1 (finger safe)

Relative Humidity 10-95%, non-condensing per IEC 68-2-3

Standards Passed

Electrostatic Discharge (ESD) IEC 61000-4-2, Level 3, 6kV contact, 8kV air

Radio Frequency Immunity, Radiated 150 MHz, 10V/m

Fast Transient Burst IEC 61000-4-4, Level 3, 4kV input power

Hi-Potential Test Meets UL508 (2 x rated V + 1000V for 1 min)

Surge

Input Power IEC 61000-4-5, Level 1

Inputs/Data Lines IEC 61000-4-5, Level 2

Safety Marks

UL UL508 (File #E68520)

CSA C22.2 (File #46510)

CE IEC 60947-6-2

Enclosure Polycarbonate

Dimensions 2.08" H x 2.776" W x 0.77" D

Weight 0.25 lb. (4 oz., 113.4 g)

Mounting Methods DIN Rail or surface mount (w/ two #8 screws)



Communication Adapters

- RS485-RS232 converter with cable & plug
- RS485-USB converter with cable & plug/RS232:USB converter

Specifications match industry standard.



The CIO-DN-P / CIO-120-DN-P are convenient and cost-effective Devicenet™ interfaces capable of providing discrete control and monitoring of motor starters, drives and other devices over a Devicenet™ network.

For more information see: See Appendix A, page 66, Figure 3 for dimensional drawing.

Features:

- Can be used in both new and existing installations
- Can be used as stand-alone or with a 777 Plus series unit
- Reduced field wiring. Unpluggable terminal block connection for network.
- Ease in system startup and commissioning
- Compact size
- DIN rail or surface mountable
- Additional remote reset input to reset 777 Plus series
- Flexible addressing standard

Approvals:  

Available Models:

CIO-DN-P
CIO-120-DN-P

Specifications

Input Characteristics

Power Requirements

Voltage (nominal).....24VDC
Current.....137mA (max.)
Power.....3.28 W (max.)

Digital Inputs

Voltage Range

CIO-DN-P.....12-24 VAC
CIO-120-DN-P.....90-130VAC

Frequency.....50/60Hz
Maximum Current.....2mA (typical)

Remote Reset.....24VDC, 10mA (min.), NO pushbutton

Output Characteristics

Form A & Form C Contactors

Pilot Duty.....480VA @ 240VAC, B300
General Purpose.....5A @ 240VAC

General Characteristics

Temperature Range.....-20° to 70°C (-4° to 158°F)

Relative Humidity.....10-95%, non-condensing
Wire Gauge.....Solid or stranded, 12-20 AWG
Terminal Torque.....3 in.-lbs.
Hi-Potential Test (relays to other circuits).....(2 x rated V + 1000V for 1 minute)
EMC Standards
Electrostatic Discharge (ESD).....IEC 61000-4-2, Level 3, 6kV contact, 8kV air
Radio Frequency Immunity, Radiated.....150 MHz, 10V/m
Fast Transient Burst.....IEC 61000-4-4, Level 3, 4kV input power
Safety Marks
UL, ULC Listed.....UL508 (File #E68520)
CSA.....C22.2 (File #46510)
Enclosure.....Polycarbonate
Dimensions.....3.4" H x 1" W x 5" D (w/ depluggable connectors)
Weight.....0.25 lb. (4 oz., 113.4 g) (w/ depluggable connectors)
Mounting Methods.....DIN Rail or surface mount (w/ two #8 screws)





The CIO-777-PR Module is a convenient and cost-effective Profibus interface capable of providing discrete control and monitoring of motor starters, drives and other devices over a Profibus network.

For more information see: See Appendix A, page 66, Figure 3 for dimensional drawing.

Features:

- Can be used in both new and existing installations
- Can be used as stand-alone or with a 777 Plus series unit
- Reduced field wiring. Simple 9-Pin sub-D connection for network
- Ease in system startup and commissioning
- Compact size
- DIN rail or surface mountable
- Additional remote reset input to reset 777 Plus series
- Flexible addressing standard

Approvals:  

Available Models:

CIO-777-PR

Specifications

Input Characteristics

Power Requirements

Voltage (nominal).....12-24VDC
Current.....150mA (max.)
Power.....3.6 W (max.)

Digital Inputs

Voltage Range

.....12-24VAC
Maximum Current.....2mA (typical)

Remote Reset.....24VDC, 10mA, (min.), NO pushbutton

Output Characteristics

Form A & Form C Contactors

Pilot Duty.....480VA @ 240VAC, B300
General Purpose.....5A @ 240VAC

General Characteristics

Ambient Temperature Range

Operating.....-20° to 70°C (-4° to 158°F)
Storage.....-40° to 80°C (-40° to 176°F)

Relative Humidity.....10-95%, non-condensing per IEC 68-2-3
Wire Gauge.....Solid or stranded, 12-20 AWG
Terminal Torque.....3 in.-lbs.
Hi-Potential Test (relays to other circuits).....Meets UL508 (2 x rated V + 1000V for 1 min.)
EMC Standards
Electrostatic Discharge (ESD).....IEC 61000-4-2, Level 3, 6kV contact, 8kV air
Radio Frequency Immunity, Radiated.....150 MHz, 10V/m
Fast Transient Burst.....IEC 61000-4-4, Level 3, 4kV input power
Safety Marks
UL, ULC Listed.....UL508 (File #E68520)
CSA.....C22.2 (File #46510)
Enclosure.....Polycarbonate
Dimensions.....3.4" H x 1" W x 5" D (w/ depluggable connectors)
Weight.....0.25 lb. (4 oz., 113.4 g) (w/ depluggable connectors)
Mounting Methods.....DIN Rail or surface mount (w/ two #8 screws)



The CIO-EN Module (non-POE)

is a convenient and cost-effective Modbus-TCP and Modbus-RTU interface capable of providing discrete control and monitoring of an overload relay over a Modbus network.

For more information see:
See Appendix A, page 66, Figure 3 for dimensional drawing.

Features:

- Can be used in both new and existing installations
- Can be used as stand-alone or with a 777 Plus series unit
- Can be re-configured to work with standard 777 units
- Reduced field wiring. Simple Ethernet™ jack connection for network
- 10 Base-T Ethernet™ compatible
- Additional Modbus port and Modbus message assembly feature for block reads
- Ease in system startup and commissioning
- Additional remote reset input to reset 777 Plus series

• Flexible addressing standard

Approvals:   

Available Models:

CIO-EN

Specifications

Input Characteristics	
Power Requirements	
Voltage.....	24VDC ±10%
Current.....	95mA (max.) 70mA (typical)
Power.....	2.28 W (max.) 1.7 W (typical)
Digital Inputs	
General Purpose (4)	
Voltage Range.....	12-24VDC
Current.....	2mA (typical)
Functional Specifications	
Remote Reset (for use with optional 777 Series)	Normally open pushbutton rated 24VDC, 10mA (min.)
Ethernet Controller	IEEE 802.3
Capability	10Base-T
Output Characteristics	
SPDT (1), SPST (1)	
Pilot Duty	480VA & 240VAC, B300
General Purpose.....	5A @ 240VAC
General Characteristics	
Ambient Operating Temperature	-20° to 70°C (-4° to 158°F)

Terminal (depluggable terminal block)	
Torque	3 in.-lbs. (max.)
Wire AWG.....	12-20 AWG
Class of Protection	IP20, NEMA 1 (finger safe)
Relative Humidity	10-95%, non-condensing per IEC 68-2-3
Standards Passed	
Electrostatic Discharge (ESD).....	IEC 61000-4-2, Level 3, 6kV contact, 8kV air
Radio Frequency Immunity, Radiated	150 MHz, 10V/m
Fast Transient Burst	IEC 61000-4-4, Level 3, 4kV input power
Hi-Potential Test.....	Meets UL508 (2 x rated V + 1000V for 1 min)
Surge	
Input Power	IEC 61000-4-5, Level 1
Inputs/Data Lines	IEC 61000-4-5, Level 2
Safety Marks	
UL.....	UL508 (File #E68520)
CSA.....	C22.2 (File #46510)
CE.....	IEC 60947-6-2
Enclosure.....	Polycarbonate
Dimensions	2.08"H x 2.776"W x 0.77"D
Weight	0.25 lb. (4 oz., 113.4 g)
Mounting Methods	DIN Rail or surface mount (w/ two #8 screws)



The Com 4-20mA Output Module

is intended for use with ONLY the Model 777-AccuPower output power monitor. The module will send a 4-20mA signal proportional to the output power. It can also be used to send the input power by setting the efficiency setting on the 777-AccuPower monitor to one. This module allows communication to a PLC with an analog input and no Modbus input.

For more information see:
See Appendix A, page 66, Figure 2 for dimensional drawing.

Features:

- Powered by the 777-AccuPower
- Scalable 4-20mA output proportional to Hp or kW
- Signal can be used for displays, controllers, or PLCs

Approvals:  

Available Models:

COM 4-20

Specifications

Output Characteristics	
Current	4-20mA
General Characteristics	
Temperature Range	-20° to 50°C (-4° to 122°F)
Terminal (depluggable terminal block)	
Torque	3 in.-lbs. (max.)
Wire AWG.....	12-20 AWG
Class of Protection	IP20
Relative Humidity	10-95%, non-condensing per IEC 68-2-3
Standards Passed	
Electrostatic Discharge	IEC 61000-4-2, Level 3, 6kV contact, 8kV air
Radio Frequency Immunity, Radiated	150 MHz, 10V/m
Fast Transient Burst.....	IEC 61000-4-4, Level 3, 4kV input power

Hi-Potential Test	Meets UL508 (2 x rated V + 1000V for 1 min)
Surge	
Input Power	IEC 61000-4-5, Level 1
Inputs/Data Lines	IEC 61000-4-5, Level 2
Safety Marks	
UL.....	UL508 (File #E68520)
CE.....	IEC 60947
Enclosure.....	Polycarbonate
Dimensions	2.08"H x 2.776"W x 0.77"D
Weight	0.25 lb. (4 oz., 113.4 g)
Mounting Method	#8 screws; mount to side of 777-AccuPower unit



The RM-1000

is a motor-monitoring device to be used in conjunction with SymCom's Model 777 family of products (excluding the P1 Series), 77C family of products and the Model 601 voltage monitors, via Modbus protocol with a communications module. The RM-1000/777 motor management system combines unsurpassed electronic motor protection and critical, user-friendly, motor monitoring.

The RM-1000 can monitor up to 16 MotorSaver® and/or PumpSaver® units through an RS-485 network using Modbus RTU protocol. A second communication port allows monitoring and control of up to 99 MotorSaver® and/or PumpSaver® units from a computer, PLC, DCS or SCADA system and can be accessed from the host computer or PLC

with the RM-1000 acting as a repeater for any of its motor protectors. In addition to the monitoring functions, the RM-1000 can be used to reset a tripped MotorSaver® or PumpSaver®.

The RM-1000 is easily mounted remotely and improves safety for service and operations personnel by allowing them to control and monitor the device without opening the electrical cabinet. Using the RM-1000 is a simple, cost-effective method for aiding compliance with arc flash safety regulations. The enclosure and keypad assembly is water and ultraviolet light resistant. The enclosure is NEMA 3R or NEMA 4X (optional) rated. The RM-1000 and RM-1000 NEMA 4 also carry a UL Type 12 rating, whereas the RM-1000-3R does not carry the UL Type 12 rating due to added weep holes. The added weep holes in the RM-1000-3R make it suitable for applications subjected to condensing moisture/humidity.

For more information see:

See Appendix A, page 67, Figure 4 for dimensional drawing.

See Appendix B, page 72, Figure 5 for typical wiring diagrams.

Features:

- Displays:
 - Individual line currents and average current
 - Current unbalance
 - Individual phase voltages and average voltage
 - Voltage unbalance
 - Present fault trip reason and restart timer status
 - Last four faults
 - MotorSaver® and/or PumpSaver® setpoints
 - Run-hours on each motor
 - Warning of pending (imminent) faults
- Controls:
 - Reset run-hour meter
 - Reset MotorSaver® or PumpSaver®
 - Clear last fault in MotorSaver® or PumpSaver®
 - Change setpoints from the RM-1000
- Convenience:
 - Power from RS485MS-2W communications module
 - Monitor up to 16 777s with one display
 - NEMA 3R outdoor rated
 - Secondary steel enclosure available (see pg 65 for details)

Approvals:   

Auxiliary Products:

- 777-P2 / 777-KW/HP-P2 Series units
- Communication modules
- RM-1000-ENCL
- Solutions Software

Available Models:

RM-1000
RM-1000-3R
RM-1000 NEMA 4

Specifications

Input Characteristics

Control Power 12-24VDC (Supplied by RS485MS-2W)

Functional Characteristics

Communication.....	Port #1 for 777(s)	Port #2 for PC, PLC, etc.
Baud Rate	1200-28800	1200-28800
Setup	None, Odd, or Even Parity	None, Odd, or Even Parity
	.1 or 2 Stop Bits	1 or 2 Stop Bits
Protocol	Modbus RTU	Modbus RTU
Serial Interface	RS-485	RS-485
Available Addresses.....	1-99 (max 16 per RM-1000)	Responds to all port #1 addresses
Mechanical Life	100,000 actuations	
Overlay Material	Polyester	
UV Exposure		
w/o degradation	2000 hrs	
Terminal Torque (depluggable terminal block)	3 in.-lbs.	
Panel Thickness	0.030" min, 0.120" max	

General Characteristics

Ambient Temperature Range	
Operating	-40° to 70°C (-40° to 158°F)
Storage.....	-40° to 80°C (-40° to 176°F)
Maximum Input Power	100mA
Class of Protection	
RM-1000, RM-1000 NEMA 4	NEMA 3R and/or UL Type12, NEMA 4X (optional)
RM-1000-3R	NEMA 3R only
Relative Humidity.....	Up to 85%, non-condensing

Safety Marks

UL.....	UL508 (File #E68520)
CSA.....	22.2 No. 14 (File #46510)
CE.....	IEC 60947-6-2

Enclosure

Material	Black polycarbonate
Display.....	Liquid Crystal with extended temp. range
Size	2 rows x 16 characters
Keypad.....	Six 0.5" stainless steel dome buttons for tactile feedback
Dimensions	3.619"H x 4.544"W x 0.9"D (91.92 x 115.42 x 22.86mm)
Weight	1.5 lbs. (24 oz., 680.39 g)
Mounting Method	Surface mountable on backplane using 4 screws



The RM-2000

is a motor-monitoring device to be used in conjunction with SymCom's Model 777 family of products (excluding the P1 Series), 77C family of products and the Model 601 voltage monitors, via Modbus protocol with a communications module. The RM-2000/777 motor management system combines unsurpassed electronic motor protection and critical, user-friendly, motor monitoring.

The RM-2000 has membrane keypad controls which allow both monitoring and control of a 777 MotorSaver[®] through an RS-485 network using Modbus RTU protocol. A second communication port allows monitoring and control of up to 99 RM-2000 devices from a PLC, DCS, or SCADA system or a PC with Solutions software installed.

The RM-2000 will act as a repeater for its motor

protector when accessed from the host computer or PLC. In addition to the monitoring functions, the RM-2000 can be used to reset a tripped MotorSaver[®] or PumpSaver[®].

The RM-2000 is easily mounted remotely and improves safety for service and operations personnel by allowing them to control and monitor the device without opening the electrical cabinet. Using the RM-2000 is a simple, cost-effective method for aiding compliance with arc flash safety regulations. The enclosure and keypad assembly is water and ultraviolet light resistant.



For more information see:

See Appendix A, page 67, Figure 5 for dimensional drawing.

See Appendix B, page 72, Figure 6 for typical wiring diagrams.

Features:

- Displays:
 - Average current, individual line currents and current unbalance
 - Current to ground
 - Average voltage, line-line voltages and voltage unbalance
 - Instantaneous power
 - Power factor
 - Last four faults
 - All parameters programmed into 777 MotorSaver[®]
 - Remaining restart delay times
- Controls:
 - Start and stop buttons
 - Key lock input to prevent setpoint changes
 - Change 777 setpoints from keypad
- The RM-2000 is also equipped with a real-time clock, which allows access to the following motor management information (most readings can be reset):
 - Total motor run-time
 - Time and date of last four faults, along with voltage and current at time of trip
 - Time and date of last 10 motor starts
 - Total number of motor restarts
 - Minimum time between any two starts with time and date
 - Run-time since last start
 - kWh consumed
 - kVARs consumed

Approvals:   

Auxiliary Products:

- 777-P2 / 777-KW/HP-P2 Series units
- Communication modules
- Solutions Software

Available Models:

RM-2000
RM-2000-CBM+
RM-2000-RTDW

Specifications

Input Characteristics			
Control Voltage	115VAC ±10%; 50/60Hz		Maximum Input Power
Transient Protection (Internal)	2500V for 10ms		3 W
Functional Characteristics			Class of Protection
Communication	Port #1 for 777	Port #2 for PC, PLC, etc.	NEMA 3R and/or UL Type 12
Baud Rate	1200-28800	1200-28800	Relative Humidity
Setup	Even Parity	None, Odd, or Even	Up to 85%, non-condensing
	1 Stop Bit	Parity 1 or 2 Stop Bits	Safety Marks
Protocol	Modbus RTU	Modbus RTU	UL
Serial Interface	RS-485	RS-485	UL508 (File #E68520)
Available Addresses	01	A01-A99	CSA
Real-time Clock			C22.2 No. 14 (File #46510)
Battery Back-up Life	10 years @ 25°C without external power		CE
Last fault memory	Stores up to 4 faults with time and date stamp, includes voltages and currents at time of trip		IIEC 60947-6-2
Configuration	Two independent electro-mechanical Form C (SPDT)		Enclosure
Contact Material	Silver/Tin Oxide		Material
Output Characteristics			Black polycarbonate
(RM-2000-RTDW version only)			Display
Pilot Duty Rating	240VA @ 120VAC		Liquid crystal with extended temp. range
General Purpose Rating	5A @ 120VAC		Size
General Characteristics			2 rows x 20 characters
Ambient Temperature Range			Lighting
Operating	-20° to 70°C (-4° to 158°F)		LED Backlight
Storage	-30° to 70°C (-22° to 158°F)		Keypad
			Eight 0.5" stainless steel dome buttons for tactile feedback
			Mechanical Life
			100,000 actuations
			Overlay Material
			Polyester
			UV Exposure w/o degradation
			2000 hrs.
			Terminal Torque (depluggable terminal block)
			3 in.-lbs.
			Dimensions
			6.4" H x 6.1" W x 1.1" D
			(162.56 x 154.94 x 27.94mm)
			Weight
			1.2 lbs. (19.2 oz., 544.31 g)
			Mounting Method
			Surface mountable on backplane using 4 screws



Solutions

is a software application that provides the ability to configure and monitor Modbus (Solutions-M) or DeviceNet™ (Solutions-D) networks. SymCom's Solutions Software features include data logging, real-time data monitoring and fault and event monitoring. Devices can be added and configured manually or the software can scan an existing network to identify devices which can be used as is or reconfigured by the user. Setpoints for each device can be uploaded and downloaded for easy monitoring and reconfiguration. Solutions-M supports both RS-485 and TCP/IP networks. Solutions-D provides support for all DeviceNet™ capable SymCom devices and most other DeviceNet™ devices, including DeviceNet™ scanners.

Requirements:

- Microsoft Windows XP or higher
- Microsoft .net Framework 2.0 (provided with Solutions)
- 300 MB of hard drive space
- RS-485 to RS-232 converter (with 1 available serial port) for Solutions-M **OR**
- RS-485 to USB converter (with 1 available USB port) for Solutions-M
- USB to CAN converter (with 1 available USB port) for Solutions-D

Auxiliary Products:

- 777-P2 / 777-KW/HP-P2 Series units
- Communication modules
- Remote Monitors

Available Models:

Solutions-D
Solutions-M



The 601-CS-D-P1

3-phase power monitor is a fully programmable electronic power monitor designed to monitor 3-phase systems. The 601-CS-D-P1 has a single relay that can be configured as a general purpose network output or to trip on ground faults. The 601-CS-D-P1 monitors ground fault current, phase currents, phase voltages, power factor and frequency. The RS485MS-2W communications module allows the 601-CS-D-P1 to communicate using the Modbus RTU protocol. The Modbus connection can be used to monitor power parameters, setup the device or control the fault relay. A DeviceNet™ communications I/O module (CIO-601CS-DN-P1) is available as well. This CIO module only works with the 601-CS-D-P1 unit. It is used for sending the information from the 601-CS-D-P1 over a DeviceNet™ network. It also provides I/O capabilities and the ability to set the parameters of the 601-CS-D-P1.

****Note:** This product must be used with an external Zero-Sequence CT for proper operation (not included).

For more information see:

See Appendix A, page 66, Figure 1 for dimensional drawing.

See Appendix B, page 73, Figure 7 for typical wiring diagrams.

Features:

- Ground fault warning (enable/delay)
- Ground fault trip (enable/trip delay)
- Ground fault motor acceleration (enable/trip delay)
- Modbus communications watchdog

Approvals:  

Auxiliary Products:

- CIO-601CS-DN-P1

Available Models:

601-CS-D-P1

Specifications

Input Characteristics		Pollution Degree3
Line Voltage200-480VAC	Class of ProtectionIP20
Frequency50/60Hz	Relative Humidity10-95%, non-condensing per IEC 68-2-3
Motor Full Load Amp Range0.5-175A (direct) 176-800A (CTs required)	Terminal Torque7in.-lbs.
Input Ground Fault Current0.5-10A	Standards Passed	
Output Characteristics		Electrostatic Discharge (ESD)IEC 61000-4-2, Level 3, 6kV contact, 8kV air
Output Contact Rating (SPDT)		Radio Frequency Immunity, ConductedIEC 61000-4-6, Level 3 10V
Pilot Duty480VA @ 240VAC	Radio Frequency Immunity, RadiatedIEC 61000-4-3, Level 3, 10 V/m
General Purpose10A @ 240VAC	Fast Transient BurstIEC 61000-4-4, Level 3, 3.5kV input power
Expected Life		Short Circuit Rating100kA RMS, SYM, 600VAC max.
Mechanical1 x 10 ⁶ operations	Surge Immunity	
Electrical1 x 10 ⁶ operations at rated load	IECIEC 61000-4-5, Level 3, 2kV line-to-line; Level 4, 4kV line-to-ground
General Characteristics		ANSI/IEEEC62.41 Surge and Ring Wave Compliance to a level of 6kV line-to-line
Ambient Temperature Range		High Potential TestMeets UL508 (2 x rated V +1000V for 1 minute)
Operating-20° to 70°C (-4° to 158°F)	Safety Marks	
Storage-40° to 80°C (-40° to 176°F)	ULUL508 (File #E68520)
Accuracy at 25° C (77° F)		CEIEC 60947-1, IEC 60947-5-1
Voltage±1%	Max Conductor Size (with insulation)0.65"
Current±3% (<175A direct)	Dimensions3.05 H x 3.85 W x 5.05 D in. (77.47 x 97.79 x 128.27 mm)
GF Current±3%	Weight1.2 lbs. (19.2 oz., 544.31 g)
Repeatability		Mounting MethodSurface mount (4 - #8 screws) or DIN rail mount
Voltage±0.5% of nominal voltage		
Current±1% (<175A direct)		
Maximum Input Power10 W		

3-Phase Voltage Monitors

All SymCom voltage monitors are microcontroller based and are factory calibrated for highly accurate and precise voltage measurements to provide high sensitivity while minimizing nuisance tripping. The high accuracy and precision of these devices allows them to detect a single-phase condition or voltage unbalance even with regenerated voltages present. Uncalibrated devices require low sensitivity to voltage faults to prevent nuisance trips, thus may not trip in the presence of regenerated voltages.

SymCom voltage monitors are built with transformer power supplies which makes them highly resistant to damage caused by small voltage transients on the power system. Other types of power supplies such as switching, resistor limited and capacitor limited, are typically more easily damaged by transients.

Product Selection Matrix

MODEL	Low Voltage	Phase-Reversal	Voltage Unbalance	Single-Phasing	Frequency Shift	High Voltage	Contact Failure	Rapid Cycling	Diagnostic LEDs	Variable Trip Point	Variable Restart Delay	Variable Trip Delay	Variable Voltage Unbalance	Manual Reset	DPDT Relay	10 Amp	15 Amp General Purpose	470VA @ 600VAC	480VA @ 600VAC Pilot Duty	8 Amp General Purpose NO	8 Amp General Purpose NC	Dual Range 190-480VAC	100V Range 95-120VAC	200V Range 190-240VAC	400V Range 380-480VAC	600V Range 475-600VAC	Voltage Band Monitor
80	•	•	•																								
102A	•	•	•	•																							
102A-2	•	•	•	•			•			•		•															
102A-3	•	•	•	•						•																	
102A-9	•	•	•	•	•																						
102-600	•	•	•	•																						•	
201A	•	•	•	•																							
201A-9	•	•	•	•	•																						
201A-AU	•	•	•	•																							
201-575-AU	•	•	•	•	•																					•	
201-100-DPDT	•	•	•	•											•	•							•				
201-200-DPDT	•	•	•	•											•	•							•				
201-100-DPDT-60mS	•	•	•	•											•	•							•				
201-200-DPDT-60mS	•	•	•	•											•	•							•				
202	•	•	•	•	•					•		•															
202-RP	•	•	•	•																							
202-575-RP	•	•	•	•																						•	
250A	•	•	•	•	•					•		•	•														
250-600	•	•	•	•	•					•		•	•													•	
350-200	•	•	•	•																							
350-200-2	•	•	•	•																							
350-200-2-6	•	•	•	•																							
350-200-2-8*	•	•	•	•																							
350-200-2-9	•	•	•	•	•																						
350-400	•	•	•	•																							
350-400-2	•	•	•	•																							
350-400-2-5	•	•	•	•																							
350-400-2-6	•	•	•	•																							
350-400-2-8*	•	•	•	•																							
350-400-2-9	•	•	•	•	•																						
350-600	•	•	•	•																							
350-600-2	•	•	•	•																						•	
350-600-2-6	•	•	•	•																						•	
350-600-2-8*	•	•	•	•																						•	
350-600-2-9	•	•	•	•	•																					•	
355-200	•	•	•	•																							
355-400	•	•	•	•																							
355-400-5	•	•	•	•																							
355-600	•	•	•	•																							
455	•	•	•	•	•																						
455-575	•	•	•	•																							
455-480R	•	•	•	•	•																					•	
460	•	•	•	•																							
460-OEM	•	•	•	•																							
460-L	•	•	•	•																							
460L-OEM	•	•	•	•																							
460-14	•	•	•	•																							
460-575-14	•	•	•	•																						•	
460-15	•	•	•	•																							
460-MR	•	•	•	•																							
460-575	•	•	•	•																							
460-VBM	•	•	•	•																							
460-400Hz	•	•	•	•																						•	
601**	•	•	•	•	•																						
601-575**	•	•	•	•	•																					•	

* These units are not equipped with manual reset as indicated on the label.
 ** Indicates units have RS-485 Modbus communication capability and digital display
 •• Indicates two relays



The Model 80

is designed to continuously monitor phase rotation of 3-phase systems. Critical applications include fan motors, scroll compressors, grinders, conveyor systems, elevators and escalators. A solid-state phase-sensing circuit drives an internal electro-mechanical relay which is energized when proper phase rotation is applied. An LED indicator illuminates when phase rotation is correct. Reset is automatic.

For more information see:
See Appendix A, page 68, Figure 6 for dimensional drawing.
See Appendix B, page 73, Figures 8 & 9 for typical wiring diagrams.

Features:

- Protects 3-phase motors from reverse phase
- Run light to indicate ABC sequence
- Universal input voltage
- CSA & CSA-NRTL/C approved

Approvals:

Available Models:

80

Specifications

Input Characteristics	
3-phase line voltage	.171-264VAC (200V Input) 342-528VAC (400V Input)
Frequency	.50/60 Hz
Functional Characteristic	
Response Time	.05 second
Output Characteristics	
Output Contact Rating (SPDT - 1 Form C)	
Pilot Duty	.480VA @ 240VAC
General Purpose	.10A @ 240VAC
General Characteristics	
Temperature Range	-.20° to 50°C (-4° to 122°F)
Maximum Input Power	.5 W
Relative Humidity	.10-95%, non-condensing per IEC 68-2-3
Standards Passed	
Fast Transient Burst	.IEC 61000-4-4, Level 2, 2kV
Surge Immunity	
IEC	.IEC 61000-4-5, Level 4, Level 3, 4kV line-to-line and line-to-ground
Safety Marks	
CSA	.C22.2 41-95 (File #LR46510)
Dimensions	
	.2"H x 2"W x 1.25"D (50.8 x 50.8 x 31.75mm)
Weight	.015 lbs (2.4 oz., 68.04 g)
Mounting Method	.#8 screw

3-Phase Voltage Monitor

3-phase voltage/phase monitor, high voltage option, panel mount, adjustable or manual restart delay

Model 102A



The Model 102A

is a 3-phase, auto-ranging, dual-range voltage monitor that protects 190-480VAC, 50*/60Hz motors regardless of size. The product provides a user selectable nominal voltage setpoint and the voltage monitor automatically selects between the 200V and 400V range.

A unique microcontroller-based voltage and phase-sensing circuit constantly monitors the 3-phase voltages to detect harmful power line conditions. When a harmful condition is detected, the MotorSaver's output relay is deactivated after a specified trip delay. The output relay reactivates after power line conditions return to acceptable levels. The Model 102A includes advanced single LED diagnostics. Five different light patterns distinguish between faults and normal conditions.

For more information see:

See Appendix A, page 68, Figure 7 for dimensional drawing.

See Appendix B, page 73, Figures 10 & 11 for typical wiring diagrams.

Options



2 - Variable Restart Delay (Manual, 2-300 seconds)

3 - Variable Trip Delay (2-30 seconds)

9 - High Voltage Detection

Features:

- Low voltage trip
- Single-phase trip
- Reverse-phase trip
- Fixed 6% voltage unbalance trip
- Single LED diagnostics
- Optional high voltage trip
- Optional variable restart delay
- Optional variable trip delay
- Separate indicators for:
 - Power-up restart delay
 - Reverse-phase trip
 - Good voltage/relay energized
 - Unbalance/single-phase trip
 - High/low voltage trip

Approvals:   

Available Models:

102A
102A-2
102A-3
102A-9
102-600

Specifications

Input Characteristics

Line Voltage	
102A	190-480VAC
102-600	475-600VAC
Frequency	50*/60Hz

Functional Characteristics

Low Voltage (% of setpoint)	
Trip	90%
Reset	93%
Voltage Unbalance (NEMA)	
Trip	6%
Reset	4.5%
Trip Delay Time	
Low/High Voltage	4 seconds (standard)
Unbalance & Phasing Faults	2 seconds
Restart Delay Time	
After a Fault	2 seconds (standard)
After a Complete Power Loss	2 seconds (standard)

Output Characteristics

Output Contact Rating (SPDT - 1 Form C)	
Pilot Duty	480VA @ 240VAC
General Purpose	10A @ 240VAC

General Characteristics

Temperature Range	-40° to 70°C (-40° to 158°F)
Maximum Input Power	.5 W

Terminal

Torque	7 in.-lbs.
Wire Size	12-18AWG
Standards Passed	
Electrostatic Discharge (ESD)	IEC 61000-4-2, Level 3, 6kV contact, 8kV air
Fast Transient Burst	IEC 61000-4-4, Level 3, 4kV input, 2kV input/output

Transient Protection (Internal)

IEC 61000-4-5; 1995 ±6kV

Safety Marks

UL	UL508 (File #E68520)
CSA	22.2 No. 14 (File #46510)
CE	IEC 60947-6-2
Dimensions	2.93" H X 5.27" W X 2.95" D (74.4 x 133.9 x 74.9mm)

Weight	1.05 lbs. (16.8 oz., 476.27 g)
Mounting Method	#8 screws

Available Options

(2) Adjustable Restart Delay	Manual, 2-300 seconds
(3) Adjustable Trip Delay	2-30 seconds (Phasing and unbalance trip delay remains at 2 seconds)

(9) High Voltage Operating Points

Trip (% of Setpoint)	110%
Reset (% of Setpoint)	107%

*Note: 50Hz will increase all delay timers by 20%.



Must use Model OT08 socket for UL Rating!

The Model 201A

is a 3-phase, auto-ranging, dual-range voltage monitor that protects 190-480VAC, 50/60Hz motors regardless of size. The product provides a user selectable nominal voltage setpoint and the voltage monitor automatically selects between the 200V and 400V range. The Model 201A includes advanced single LED diagnostics, where five different light patterns distinguish between faults and normal conditions.

This unique microcontroller-based voltage and phase-sensing device constantly monitors the 3-phase voltages to detect harmful power line conditions. When a harmful condition is detected, the MotorSaver's output relay is deactivated after a specified trip delay. The output relay reactivates after power line conditions return to acceptable levels.

For more information see:

See Appendix A, page 68, Figure 8 for dimensional drawing.



See Appendix B, pages 73 & 74, Figures 12 & 13 for typical wiring diagrams.

Option

9 - High Voltage Detection

Features:

- Low voltage trip
- Single-phase trip
- Reverse-phase trip
- Fixed 6% voltage unbalance trip
- Single LED diagnostics
- Optional high voltage trip
- 8-pin plug-in; DIN rail or surface mount
- Separate indicators for:
 - Power-up restart delay
 - Reverse-phase trip
 - Good voltage/relay energized
 - Unbalance/single-phase trip
 - High/low voltage trip

Approvals:  

Auxiliary Products:

- 8-pin octal socket (P/N: CT0T08-PC)

Available Models:

201A
201A-9

Specifications

Input Characteristics	
Line Voltage	190-480VAC
Frequency	50/60Hz
Functional Characteristics	
Low Voltage (% of setpoint)	
Trip	.90%
Reset	.93%
Voltage Unbalance (NEMA)	
Trip	.6%
Reset	.4.5%
Optional High Voltage (% of setpoint)	
Trip	.110%
Reset	.107%
Trip Delay Time	
High/Low Voltage Fault	.4 seconds
Unbalance & Phasing Faults	.2 seconds
Restart Delay Time	
After a Fault	.2 seconds
After a Complete Power Loss	.2 seconds
Output Characteristics	
Output Contact Rating (SPDT)	
Pilot Duty	480VA @ 240VAC
General Purpose	10A @ 240VAC
General Characteristics	
Temperature Range	-40° to 70°C (-40° to 158°F)
Maximum Input Power	.5 W
Relative Humidity	10-95%, non-condensing per IEC 68-2-3
Terminal Torque	.12 in.-lbs.
Wire Gauge	12-22 AWG Solid or stranded
Transient Protection (Internal)	2500V for 10 ms
Standards Passed	
Electrostatic Discharge (ESD)	IEC 61000-4-2, Level 3, 6kV contact, 8kV air
Radio Frequency Immunity (RFI), Radiated	150MHz, 10V/m
Fast Transient Burst	IEC 61000-4-4, Level 3, 3.5kV input power & controls
Surge Immunity	
IEC	IEC 61000-4-5, Level 3, 4kV line-to-line; Level 4, 4kV line-to-ground
ANSI/IEEE	C62.41 Surge and Ring Wave Compliance to a level of 6kV line-to-line
Hi-potential Test	Meets UL508 (2 x rated V + 1000V for 1 minute)
Safety Marks	
UL (OT08 octal socket required)	UL508 (File #E68520)
CE	IEC 60947-6-2
Dimensions	1.750" H x 2.375" W x 4.125" D (with socket) (44.45 x 60.325 x 104.775mm)
Weight	0.7 lbs. (11.2 oz., 317.51 g)
Mounting Method	DIN rail or surface mount (plug in to OT08 socket)
Socket Available	Model OT08-PC (UL Rating 600V)
The 600V socket can be surface mounted or installed on DIN Rail.	

3-Phase Voltage Monitor

3-phase voltage/phase monitor, 8-pin socket mount, adjustable trip/restart delays & voltage unbalance percentage

Model 201A-AU



Must use Model OT08 socket for UL Rating!

The Model 201A-AU

is a 3-phase, auto-ranging, dual-range voltage monitor that protects 190-480VAC, 50/60Hz motors regardless of size. The product provides a user selectable nominal voltage setpoint and the voltage monitor automatically selects between the 200V and 400V range. The Model 201A-AU includes advanced single LED diagnostics, where five different light patterns distinguish between faults and normal conditions. Adjustment knobs allow the user to set a 1-30 second trip delay, a manual restart or 1-500 second restart delay and a 2-8% voltage unbalance trip point.

This unique microcontroller-based voltage and phase-sensing device constantly monitors the 3-phase voltages to detect harmful power line conditions. When a harmful condition is detected, the MotorSaver's output relay is deactivated after a specified trip delay. The output relay reactivates after power line conditions return to acceptable levels.

For more information see:

See Appendix A, page 68, Figure 8 for dimensional drawing.

See Appendix B, page 74, Figures 14 & 15 for typical wiring diagrams.

Features:

- Protects 3-phase motors from:
 - Loss of any phase (single phasing)
 - Low voltage
 - High voltage
 - Voltage unbalance
 - Phase reversal
 - Rapid cycling
- 8-pin plug-in; DIN rail or surface mountable
- Manual reset option provides last fault detection
- Auto-ranging voltage
- Advanced LED diagnostics
- Adjustable voltage unbalance trip setting
- Adjustable trip & restart delay settings

Approvals:  

Auxiliary Products:

- 8-pin octal socket (P/N: CT0T08-PC)

Available Models:

201A-AU
201-575-AU
201A-AU-OT (sold with OT08 socket)
201-575-AU-OT (sold with OT08 socket)

Specifications

Input Characteristics

Line Voltage	
201A-AU	190-480VAC
201-575-AU	475-600VAC
Frequency	50/60Hz

Functional Characteristics

Low Voltage (% of setpoint)	
Trip	90% ±1%
Reset	93% ±1%
High Voltage (% of setpoint)	
Trip	110% ±1%
Reset	107% ±1%
Voltage Unbalance (NEMA)	
Trip	2-8% adjustable
Reset	Trip Setting Minus 1% (5-8%) Trip Setting Minus 0.5% (2-4%)

Trip Delay Time

High, Low and Unbalanced Voltage	1-30 seconds adjustable
Single-Phasing Faults	1 second fixed
Restart Delay Time	
After a Fault	Manual, 1-500 seconds adj.
After a Complete Power Loss	Manual, 1-500 seconds adj.

Output Characteristics

Output Contact Rating (1-Form C)	
Pilot Duty	480VA @ 240VAC, B300
General Purpose	10A @ 240VAC

General Characteristics

Ambient Temperature Range	
Operating	-40° to 70°C (-40° to 158°F)
Storage	-40° to 80°C (-40° to 176°F)
Maximum Input Power	.5 W
Relative Humidity	10-95%, non-condensing per IEC 68-2-3
Standards Passed	
Electrostatic Discharge (ESD)	IEC 61000-4-2, Level 3, 6kV contact, 8kV air
Radio Frequency Immunity, Radiated	150 MHz, 10V/m
Fast Transient Burst	IEC 61000-4-4, Level 3, 3.5kV input power & controls
Surge	
IEC	IEC 61000-4-5, Level 3, 4kV line-to-line; Level 4, 4kV line-to-ground
ANSI/IEEE	C62.41 Surge and Ring Wave Compliance to a level of 6kV line-to-line
Hi-potential Test	Meets UL508 (2 x rated V +1000V for 1 min.)
Safety Marks	
UL (OT08 octal socket required)	UL508 (File #E68520)
CE	IEC 60947-6-2
Enclosure	Polycarbonate
Dimensions	1.750" H x 2.375" W x 4.125" D (with socket) (44.45 x 60.325 x 104.775mm)
Weight	0.7 lb. (11.2 oz., 317.51 g)
Mounting Method	DIN rail or surface mount (plug in to OT08 socket)
Socket Available	Model OT08 (UL Rating 600V)

The 600V socket can be surface mounted or installed on DIN Rail.

3-Phase Voltage Monitor

3-phase voltage/phase monitor, 11-pin socket mount, two isolated Form C relays

Model 201-xxx-DPDT



Must use Model OT11 socket for UL Rating!

The Model 201-xxx-DPDT

is an 11-pin octal base plug-in voltage monitor designed to protect 3-phase motors regardless of size. The 201-100-DPDT is used on 95-120VAC, 50/60Hz motors and the 201-200-DPDT is used on 190-240VAC, 50/60Hz motors to prevent damage caused by incoming voltage problems. The units feature two isolated sets of contacts that are ideal for use with two control circuits with different voltages.

The unique microcontroller-based voltage and phase-sensing circuit constantly monitors the voltages to detect harmful power line conditions. When a harmful condition is detected, the MotorSaver's output relays are deactivated after a specified trip delay. The output relays reactivate after power line conditions return to an acceptable level and a specified amount of time has elapsed (restart delay). The trip delay prevents nuisance tripping due to rapidly fluctuating power line conditions.

This unit is also available with a shorter trip delay and faster restart delay. The 201-xxx-DPDT-60mS has a trip delay of 0.5 seconds and a restart delay of 60 milliseconds.



For more information see:

See Appendix A, page 68, Figure 8 for dimensional drawing.

See Appendix B, page 74, Figure 16 for typical wiring diagrams.

Features:

- Low voltage protection
- Single-phase protection
- Reverse-phase protection
- Voltage unbalance protection
- Two isolated Form C relays (DPDT)
- Diagnostic LED
- 11-pin plug-in; DIN rail or surface mount

Approvals:  

Auxiliary Products:

- 11-pin octal socket (P/N: OT11-PC)

Available Models:

201-100-DPDT
201-200-DPDT
201-100-DPDT-60mS
201-200-DPDT-60mS

Specifications

Input Characteristics

Line Voltage
201-100-DPDT, 201-100-DPDT-60mS95-120VAC
201-200-DPDT, 201-200-DPDT-60mS190-240VAC
Frequency50/60Hz

Functional Characteristics

Low Voltage (% of setpoint)
Trip90% $\pm 1\%$
Reset93% $\pm 1\%$

Voltage Unbalance
Trip6%
Reset4.5%

Trip Delay Times

Low Voltage4 seconds
Unbalance, Phasing Faults2 seconds
Models with -60ms option0.5 second

Restart Delay Times

After a Fault or Complete Power Loss2 seconds
Models with -60ms option60 milliseconds

Output Characteristics

Output Contact Rating (DPDT)
Pilot Duty480VA @ 240VAC
General Purpose10A @ 240VAC

General Characteristics

Temperature Range-40° to 70°C (-40° to 158°F)
Maximum Input Power5 W
Standards Passed
Electrostatic Discharge (ESD)IEC 61000-4-2, Level 3, 6kV contact, 8kV air
Radio Frequency Immunity, Radiated150MHz, 10V/m
Fast Transient BurstIEC 61000-4-4, Level 3, 2.5kV input power and controls

Safety Marks

UL (OT11 octal socket required)UL508 (File #E68520)
CEIEC 60947-6-2

Dimensions1.750" H x 2.375" W x 4.125" D (with socket)

Weight0.65 lb. (10.4 oz., 294.84 g)

Mounting MethodDIN rail or surface mount (plug in to OT11 socket)

Socket AvailableModel OT11 (UL Rated 300V)

The 300V socket can be surface mounted or installed on DIN Rail.

3-Phase Voltage Monitor

3-phase voltage/phase monitor, panel mount, adjustable or manual restart delay
(-RP reverse-phase protection only)

Model 202 / 202-RP



The Model 202

is a 3-phase, auto-ranging, dual-range voltage monitor that protects 190-480VAC, 50*/60Hz motors regardless of size. The product provides a user selectable nominal voltage setpoint and the voltage monitor automatically selects between the 200V and 400V range.

This unique microcontroller-based voltage and phase-sensing device constantly monitors the 3-phase voltages to detect harmful power line conditions. When a harmful condition is detected, the MotorSaver's output relay is deactivated after a specified trip delay. The output relay reactivates after power line conditions return to acceptable levels. The Model 202 includes advanced single LED diagnostics. Five different light patterns distinguish between faults and normal conditions.

The Model 202-RP

monitors the phase rotation of 3-phase systems and trips on reverse phase only. Critical applications include fan motors, scroll compressors, grinders, conveyor systems, elevators and escalators. The status light turns green and the relay is activated when rotation is correct.

For more information see:

See Appendix A, page 68, Figure 9 for dimensional drawing.

See Appendix B, page 74, Figures 17 & 18 for typical wiring diagrams.

Features:

- Quick mounting with single screw
- Small package, ideal for assembly into panels
- Standard 1/4" quick connects
- Adjustable restart delay

Approvals: 

Available Models:

202
202-RP
202-575-RP

Specifications

Input Characteristics

Line Voltage	
202, 202-RP	190-480VAC
202-575-RP	475-600VAC
Frequency	50*/60Hz

Functional Characteristics

Phase Sequence	ABC
Low Voltage (% of setpoint)	
Trip	90%
Reset	93%
High Voltage (% of setpoint)	
Trip	110%
Reset	107%
Voltage Unbalance (NEMA)	
Trip	6%
Reset	4.5%
Trip Delay Time	
High and Low Voltage	4 seconds
Unbalance & Phasing Faults	2 seconds
Restart Delay Time	
After a Fault	Manual, 2-300 seconds adj.
After a Complete Power Loss	Manual, 2-300 seconds adj.

Output Characteristics

Output Contact Rating (SPDT)	
Pilot Duty	480VA @ 240VAC
General Purpose	10A @ 240VAC

General Characteristics

Temperature Range	-40° to 70°C (-40° to 158°F)
Trip & Reset Accuracy	±1%
Repeatability	±0.5%
Maximum Input Power	5 W
Relative Humidity	95%, non-condensing
Transient Protection	IEC 61000-4-5, ±4kV
Input to Output Dielectric	1960 Vrms min.
Termination	0.25" male quick connect
Safety Marks	
UL	UL508 (File #E68520)
Dimensions	2.5" H x 2.5" W x 1.4" D (63.5 x 63.5 x 35.56mm)
Weight	0.5 lb. (8 oz., 226.8 g)
Mounting Method	1/4" socket head cap screw (customer supplied)

*Note: 50Hz will increase all delay timers by 20%.
CE Pending

3-Phase Voltage Monitor

3-phase voltage/phase monitor, panel mount, adjustable or manual restart delay,
2 Form C relay contacts

Model 250A



The Model 250A

is a 3-phase, auto-ranging, dual-range voltage monitor that protects 190-480VAC, 50*/60Hz motors regardless of size. The product provides a user selectable nominal voltage setpoint and the voltage monitor automatically selects between the 200V and 400V range.

This unique microcontroller-based voltage and phase-sensing device constantly monitors the 3-phase voltages to detect harmful power line conditions. When a harmful condition is detected, the MotorSaver's output relay is deactivated after a specified trip delay. The output relay reactivates after power line conditions return to acceptable levels. The Model 250A includes advanced single LED diagnostics. Five different light patterns distinguish between faults and normal conditions.



For more information see:

See Appendix A, page 68, Figure 7 for dimensional drawing.

See Appendix B, page 75, Figure 19 for typical wiring diagrams.

Features:

- Low voltage trip
- High voltage trip
- Single-phase trip
- Reverse-phase trip
- Fixed 6% voltage unbalance trip
- Single LED diagnostics
- Adjustable restart delay
- Manual reset selection
- DPDT relay output
- Separate indicators for:
 - Power-up restart delay
 - Reverse-phase trip
 - Good voltage/relay energized
 - Unbalance/single-phase trip
 - High/low voltage trip

Approvals:   

Available Models:

250A
250-600

Specifications

Input Characteristics

Line Voltage	
250A	190-480VAC
250-600	475-600VAC
Frequency	50*/60Hz

Functional Characteristics

Low Voltage (% of setpoint)	
Trip	90%
Reset	93%
High Voltage (% of setpoint)	
Trip	110%
Reset	107%
Voltage Unbalance (NEMA)	
Trip	6%
Reset	4.5%
Trip Delay Time	
Low Voltage, High Voltage	4 seconds
Unbalance, Phasing Faults	2 seconds
Restart Delay Time	
After a Fault or Complete Power Loss	Manual, 2-300 seconds adj.

Output Characteristics

Output Contact Rating (DPDT - 2 Form C)	
Pilot Duty	480VA @ 240VAC
General Purpose	10A @ 240VAC
General Characteristics	
Temperature Range	-40° to 70°C (-40° to 158°F)
Maximum Input Power	5 W
Relative Humidity	Up to 95% non-condensing per IEC 68-2-3
Terminal	
Torque	7 in.-lbs.
Wire Size	12-18AWG
Transient Protection (Internal)	IEC 61000-4-5;1995 ±6kV
Safety Marks	
UL	UL508 (File #E68520)
CSA	22.2 No. 14 (File #46510)
CE	IEC 60947-6-2

Dimensions	2.93"H x 5.27"W x 2.95"D (74.4 x 133.9 x 74.9mm)
Weight	1.02 lb. (16.32 oz., 462.66 g)
Mounting Method	#8 screws

*Note: 50Hz will increase all delay timers by 20%.

3-Phase Voltage Monitor

3-phase voltage/phase monitor, panel mount, optional 1 or 2 15A rated relay contacts

Model 350



The Model 350

is a heavy-duty voltage monitor. This product should be used when high current relays or dual contacts are required, or 480V controls are used. Since the Model 350 uses heavy-duty relays, it comes in fixed voltage range models rather than a dual auto-ranging version like the Model 250.

The Model 350-200 has a 15A general purpose contact. The Model 350-400 provides a SPDT (Form C) relay rated to switch up to 600V, allowing the use of 480V controls, eliminating the need for a control power transformer to step the voltage down to 120-240V. Several DPDT (two Form C contacts) relay models are also available.

The Model 350 microcontroller-based family of products are low cost yet highly advanced solutions to heavy-duty problems. The Model 350 includes advanced single LED diagnostics. Five different light patterns distinguish faults and normal operating conditions. Other options such as high voltage trip, adjustable trip delay and adjustable restart delay are available.

For more information see:

See Appendix A, page 68, Figure 7 for dimensional drawing.



See Appendix B, page 75, Figure 20 for typical wiring diagrams.

Options

- 2 - Variable Restart Delay (Manual, 2-300 seconds)
- 5 - DPDT Relay
- 6 - 2 Relays (1) 10A, (1) 15A
- 8 - 2 Relays (2) 15A
- 9 - High Voltage Detection

Features:

- Low voltage trip
- Optional high voltage trip
- Single-phase trip
- Reverse-phase trip
- Fixed 6% voltage unbalance trip
- Single LED diagnostics
- Separate indications for:
 - Power-up restart delay
 - Reverse-phase trip
 - Good voltage/relay energized
 - Unbalance/single-phase trip
 - High/low voltage trip

Approvals:   

Available Models:

- 350-200
- 350-200-2
- 350-200-2-6
- 350-200-2-8**
- 350-200-2-9
- 350-400
- 350-400-2
- 350-400-2-5
- 350-400-2-6
- 350-400-2-8**
- 350-400-2-9
- 350-600
- 350-600-2
- 350-600-2-6
- 350-600-2-8**
- 350-600-2-9

Specifications

Input Characteristics

Line Voltage	
350-200	190-240VAC
350-400	380-480VAC
350-600	475-600VAC
Frequency	50*/60Hz

Functional Characteristics

Low Voltage (% of setpoint)

Trip	90%
Reset	93%

Voltage Unbalance (NEMA)

Trip	6%
Reset	4.5%

Trip Delay Time

Low Voltage	4 seconds
Unbalance & Phasing Faults	2 seconds

Restart Delay Time

After a Fault	2 seconds
After a Complete Power Loss	2 seconds

Output Characteristics

Output Contact Rating

SPDT (350-200)	
Pilot Duty	480VA @ 240VAC
General Purpose	15A
SPDT (350-400, 350-600)	470VA @ 600VAC
DPDT (-6 Option)	1-10A General Purpose
	480VA @ 240VAC Pilot Duty
	1-15A General Purpose
	480VA @ 240VAC Pilot Duty
	1hp @ 240VAC

DPDT (-8 Option)	2-15A General Purpose
	480VA @ 240VAC Pilot Duty
	1hp @ 240VAC

General Characteristics

Ambient Temperature Range	
Operating	-40° to 70°C (-40° to 158°F)
Storage	-40° to 80°C (-40° to 176°F)
Maximum Input Power	5 W
Terminal	
Torque	7 in.-lbs.
Wire Size	12-18AWG
Transient Protection (Internal)	IEC 61000-4-5;1995 ±6kV
Safety Marks	
UL	UL508 (File #E68520)
CSA	22.2 No. 14 (File #46510)
CE	IEC 60947-6-2
Dimensions	2.93"H x 5.27"W x 2.95"D
	(74.4 x 133.9 x 74.9mm)
Weight	1.05 lbs. (16.8 oz., 476.27 g)
Mounting Method	#8 screws

Special Options

Option 2 - Variable Restart Delay	Manual, 2-300 seconds adj.
Option 5 - DPDT Relay	
Option 6 - 2 Relays (1) 10A, (1) 15A	
Option 8 - 2 Relays (2) 15A	
Option 9 - High Voltage (% of setpoint)	
Trip	110%
Reset	107%

*Note: 50Hz will increase all delay timers by 20%.

** These units are not equipped with Manual Reset.

3-Phase Voltage Monitor

3-phase voltage/phase monitor, panel mount, adjustable trip/restart delays & voltage unbalance percentage, optional 2 each 480V-rated relays

Model 355



The Model 355

is a 3-phase voltage monitor with adjustable trip and restart delay, adjustable voltage unbalance and multiple diagnostic lights. It is perfect for heavy-duty applications that need both protection and simple user-friendly diagnostics. Applications include pump panels, commercial HVAC, oil rigs and others.

The Model 355 uses microcontroller technology to monitor incoming voltage and de-energize its output relay if power problems exist. The Model 355 can protect motors from damage caused by single-phasing, high and low voltage, phase reversal and voltage unbalance. It has four diagnostic LEDs that clearly show overvoltage, undervoltage, voltage unbalance, reverse-phase and normal conditions.

The Model 355-200 is equipped with a heavy-duty 10A general purpose SPDT relay. The Model 355-400 and 355-600 are equipped with a 470VA @ 600VAC pilot duty SPDT relay. A high voltage (600V) DPDT relay output option is available with the 400V model.

For more information see:

See Appendix A, page 68, Figure 7 for dimensional drawing.

See Appendix B, page 75, Figures 21 & 22 for typical wiring diagrams.

Option

5 - DPDT Relay

Features:

- Standard high voltage relay for 400V and 600V ranges
- Multiple LEDs provide diagnostics
- Adjustable trip and restart delays

Approvals: 

Available Models:

- 355-200
- 355-400
- 355-400-5
- 355-600

Specifications

Input Characteristics

Line Voltage	
355-200	.190-240VAC
355-400	.380-480VAC
355-600	.475-600VAC

(Specify voltage range)

Frequency	.50*/60Hz
-----------	-----------

Functional Characteristics

Low Voltage (% of setpoint)	
Trip	.90% ±1%
Reset	.93% ±1%
High Voltage (% of setpoint)	
Trip	.110% ±1%
Reset	.107% ±1%
Voltage Unbalance (NEMA)	
Trip	.2-8% adjustable
Reset	.Trip setting minus 1%

Trip Delay Time

Low & High Voltage and Unbalance	.2-30 seconds adjustable
Single-phasing Faults (>25% UB)	.2 seconds

Restart Delay Time

After a Fault or Power Loss	.Manual, 2-300 seconds adj.
-----------------------------	-----------------------------

Output Characteristics

Output Contact Rating

SPDT (355-200)	
Pilot Duty	.480VA at 240VAC
General Purpose	.10A

SPDT (355-400, 355-600)

Pilot Duty	.470VA @ 600VAC
DPDT (-5 Option)	
Pilot Duty	.470VA @ 600VAC

General Characteristics

Temperature Range	
Operating	-.40° to 70°C (-40° to 158°F)
Storage	-.40° to 80°C (-40° to 176°F)
Repeat Accuracy	
Fixed Conditions	±0.1%
Maximum Input Power	.6 W
Terminal	
Torque	.7 in.-lbs.
Wire Size	.12-18AWG
Transient Protection (Internal)	.2500V for 10 ms
Safety Marks	
UL	.UL508 (File #E68520)
Dimensions	.2.93"H x 5.27"W x 2.95"D (74.4 x 133.9 x 74.9mm)
Weight	.0.94 lb. (15.04 oz., 426.38 g)
Mounting Method	.#8 screws

Special Options

Option 5 - DPDT Relay

*Note: 50Hz will increase all delay times by 20%.

3-Phase Voltage Monitor

Model 455

3-phase voltage/phase monitor, panel mount, has add'l voltage inputs for monitoring load side of contactor for contactor failure & works with Informer-MS diagnostic tool



The Model 455

3-phase voltage monitor combines load and line side monitoring to alert the user of contactor failure or impending contactor failure. The line side monitoring will protect the motor from damaging line side conditions prior to the motor starting. With other line-load side voltage monitors, the motor must be started before a voltage problem is detected. With the Model 455, the motor is fully protected at all times. The motor will not start when a power problem is present.

The Model 455 is a 3-phase, auto-ranging, dual-range voltage monitor that protects 190-480VAC, 50*/60Hz motors regardless of size. The product provides a user selectable nominal voltage setpoint and the voltage monitor automatically selects between the 200V and 400V range. Other

adjustments include a 2-30 second trip delay, a 2-300 second restart delay (and manual restart) and a voltage unbalance trip point adjustment from 2-8%.

Four LEDs indicate the status of the Model 455: run light, undervoltage, overvoltage and phasing fault. The Model 455 is a load and line side monitor that does not require a separate power source for its electronics, making it much easier to install.

The Model 455 now has an infrared LED to communicate with the new Informer-MS. Just aim the handheld diagnostic tool at the 455 to get valuable information such as real-time voltage and voltage unbalance on both line and load sides, motor run hours, last 20 faults, last 32 motor starts, high and low voltage trip points, voltage unbalance trip point, restart and trip delay settings, MotorSaver® status and more!

For more information see:

See Appendix A, page 68, Figure 7 for dimensional drawing.

See Appendix B, page 75, Figures 23 & 24 for typical wiring diagrams.

Features:

- Load side monitoring of contactor
- Multiple LEDs for diagnostics, special indicators for overvoltage, undervoltage and phasing faults
- Prevents rapid cycling by monitoring contactor or starter
- Infrared LED to communicate with Informer-MS

Approvals:   

Auxiliary Products:

- Informer-MS
- IR Kit-36 (36" infrared adapter cable)

Available Models:

455
455-480R
455-575

Specifications

Input Characteristics

Line Voltage	
455	190-480VAC
455-575	475-600VAC
455-480R	380-480VAC
Frequency	50*/60Hz

Functional Characteristics

Low Voltage (% of setpoint)	
Trip	90% ±1%
Reset	93% ±1%
High Voltage (% of setpoint)	
Trip	110% ±1%
Reset	107% ±1%
Voltage Unbalance (NEMA)	
Trip	2-8% adjustable
Reset	Trip setting minus 1%
Trip Delay Time	
Low & High Voltage and Unbalance	2-30 seconds adjustable
Single-phasing Faults (>25% UB)	2 seconds fixed
Restart Delay Time	
After a Fault	Manual, 2-300 seconds adj.
After a Complete Power Loss	Manual, 2-300 seconds adj.
After a Motor Shut-down	Manual, 2-300 seconds adj.

Output Characteristics

Output Contact Rating (SPDT)	
Pilot Duty	480VA @ 240VAC
General Purpose	10A
High Voltage Relay (-480R)	
Pilot Duty	470VA @ 600VAC
General Characteristics	
Ambient Temperature Range	
Operating	-40° to 70°C (-40° to 158°F)
Storage	-40° to 80°C (-40° to 176°F)
Repeat Accuracy	
Fixed Conditions	±0.1%
Maximum Input Power	6 W
Terminal	
Torque	.7 in.-lbs.
Wire Size	12-18AWG
Transient Protection (Internal)	IEC 61000-4-5;1995 ±6kV
Safety Marks	
UL	UL508 (File #E68520)
CSA	C22.2 No. 14 (File #46510)
CE	IEC 60947-6-2
Dimensions	2.93"H x 5.27"W x 2.95"D (74.4 x 133.9 x 74.9mm)
Weight	1.1 lbs. (17.6 oz., 498.95 g)
Mounting Method	#8 screws

*Note: 50Hz will increase all delay times by 20%.

3-Phase Voltage Monitor

wireless hand-held diagnostic tool reads Model 455 to display last 20 fault causes, real-time voltage/phase & much more

Model Informer-MS

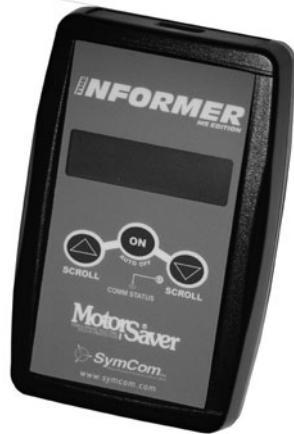

The Informer-MS

is a handheld diagnostic tool designed for use with MotorSaver® Model 455* equipped with an infrared LED transmitter.

The Informer-MS uses an infrared receiver to read valuable information transmitted from the Model 455*, which can be helpful for troubleshooting the system. A green communication status light indicates the Informer-MS is receiving data from the MotorSaver®. If communication is lost, the Informer-MS will display the last values it received.

*Model 455s manufactured after 03/01/06 are equipped with the infrared LED transmitter. Models manufactured prior to this date are not compatible with the Informer-MS.

An infrared adapter can be purchased to allow communication with the Model 455 without opening the panel door.

For more information see:

See Appendix A, page 69, Figure 10 for dimensional drawing.

Features:

The Informer-MS displays:

- Real-time, line and load side voltage
- Real-time, line and load side voltage unbalance
- Motor run hours
- Last 20 faults
- Last 32 motor starts
- High and low voltage trip points
- Voltage unbalance trip point
- Restart and trip delay settings
- Voltage at last fault

Auxiliary Products:

- Model 455 Series
- IR Kit-36 (36" infrared adapter cable)

Available Models:

Informer-MS

Specifications

Functional Characteristics

Power	
Input	9 Volts DC (requires one 9-volt alkaline battery)
Auto Shut-off	2 minutes
Communication	
Signal	Infrared
Range	1-8 ft.
Data Update	4 seconds
General Characteristics	
Temperature Range	0 to 60°C (32° to 140°F)
Accuracy	
Voltage	±2%
Maximum Input	0.25 W
Resolution	
Voltage	1.0VAC
Display (Liquid crystal)	
Size	2 rows x 16 characters
Keypad	Three 0.5" buttons
Mechanical Life	500,000 actuations
Overlay Material	Lexan
Enclosure	
Dimensions	5.50" H x 3.6" W x 1.125" D (139.7 x 91.44 x 28.58mm)
Weight	0.5 lb. (8 oz., 226.8 g) (w/out battery)
Material	Black ABS

3-Phase Voltage Monitor

3-phase voltage monitor, *din rail mount, adj trip/restart delays & V unbalance %, and options for 2 individual contacts, adj high/low voltage trip pts & much more*

Model 460 Product Line



The Model 460

is a 3-phase, auto-ranging, dual-range voltage monitor that protects 190-480VAC, 50/60Hz motors regardless of size. The product provides a user selectable nominal voltage setpoint and the voltage monitor automatically selects between the 200V and 400V range. The 460's wide operating range, combined with UL and CE compliance, enables quick access to domestic and global markets.

This unique microcontroller-based voltage and phase-sensing device constantly monitors the 3-phase voltages to detect harmful power line conditions. When a harmful condition is detected, the MotorSaver's output relay is deactivated after a specified trip delay. The output relay reactivates after power line conditions return to an acceptable

level for a specified amount of time (restart delay). The trip and restart delays prevent nuisance tripping due to rapidly fluctuating power line conditions.

The Model 460 automatically senses whether it is connected to a 190-240V, 60Hz system, a 440-480V, 60Hz system or a 380-416V, 50Hz system. An adjustment is provided to set the nominal line voltage from 190-240 or 380-480VAC. Other adjustments include a 1-30 second trip delay, a 1-500 second restart delay and a 2-8% voltage unbalance trip point.

-L The 460-L is similar to a 460, but without the adjustable voltage unbalance and variable trip delay. These are fixed at 6% for unbalance and 4 seconds for high, low and unbalanced voltage and 1 second for single phase.

-575 The 460-575 is intended for incoming power sources between 470VAC and 600VAC. Most commonly used in Eastern Canada and on generation units that generate 600VAC power.

-MR The 460-MR is used for any application that needs to have an external manual reset button. It is equipped with a two-prong connection to hook to a normally open pushbutton, which can be mounted outside a panel, therefore eliminating the need to open the panel to reset the unit.

-14 The 460-14 has two sets of contacts, 1 form A and 1 form B, for differing applications where two different voltages may be required, such as 5VDC for an input to a PLC and 115VAC for an alarm.

-15 The 460-15 has two sets of contacts, 2 form A, for applications where two different units are to be controlled at once, such as a unit that has separate contacts for a compressor and a fan.

-VBM The 460-VBM is designed so the user can set specific low and high voltage trip points. They also have a 1-30 second trip delay and 1-500 second restart delay. The voltage unbalance is fixed at 6%.

-400HZ The 460-400HZ is intended for applications that have a 400Hz power supply rather than 50-60Hz, such as aircraft and marine applications. It has all the features of the regular 460, such as the variable restart delay, voltage unbalance (2-8%) and restart delay. Auto ranging from 190-480VAC.

See Appendix A, page 69, Figure 11 for dimensional drawing.

See Appendix B, page 76, Figure 25 for typical wiring diagram; Figure 26 for a typical wiring diagram for the 460-14 & 460-15.

Specifications

Input Characteristics		Form A & Form B	
Line Voltage		Pilot Duty	360VA @ 240VAC, B300
460, 460-L, 460-MR, 460-14, 460-15	190-480VAC	General Purpose	8A @ 240VAC
460-VBM, 460-400HZ	190-480VAC	General Characteristics	
460-575, 460-575-14	475-600VAC	Ambient Temperature Range	
Frequency	50/60Hz	Operating	-40° to 70°C (-40° to 158°F)
Functional Characteristics		Storage	-40° to 80°C (-40° to 176°F)
Low Voltage (% of setpoint)		Maximum Input Power	6 W
Trip	90% ±1%	Class of Protection	IP20, NEMA 1 (finger safe)
Reset	93% ±1%	Relative Humidity	10-95%, non-condensing per IEC 68-2-3
High Voltage (% of setpoint)		Terminal Torque	6 in.-lbs.
Trip	110% ±1%	Wire Type	Stranded or solid 12-20 AWG, one per terminal
Reset	107% ±1%	Standards Passed	
Voltage Unbalance (NEMA)		Electrostatic Discharge (ESD)	IEC 61000-4-2, Level 3, 6kV contact, 8kV air
Trip	2-8% adjustable	RFI, Radiated	150 MHz, 10V/m
Reset	Trip setting minus 1% (5-8%) Trip setting minus 0.5% (2-4%)	Fast Transient Burst	IEC 61000-4-4, Level 3, 3.5kV input power & controls
460L	6% UB fixed (4.5% reset)	Surge	IEC 61000-4-5, Level 3, 4kV line-to-line; Level 4, 4kV line-to-ground
Trip Delay Time		ANSI/IEEE	C62.41 Surge and Ring Wave Compliance to a level of 6kV line-to-line
Low, High and Unbalanced Voltage	1-30 seconds adjustable	Hi-potential Test	Meets UL508 (2 x rated V +1000V for 1 minute)
460L	4 seconds fixed	Safety Marks	
Single-Phase Faults (>25% UB)	1 second fixed	UL	UL508 (File #E68520)
Restart Delay Time		CE	IEC 60947-6-2
After a Fault	1-500 seconds adjustable	Enclosure	Polycarbonate
After a Complete Power Loss	1-500 seconds adjustable	Dimensions	3.5" H X 2.084" W X 2.350" D (88.9 x 52.93 x 59.69mm)
Output Characteristics		Weight	0.7 lb. (11.2 oz., 317.51 g)
Output Contact Rating		Mounting Method	35mm DIN rail or Surface Mount (#6 or #8 screws)
Form C		460-MR (manual reset)	External NO pushbutton required.
Pilot Duty	480VA @ 240VAC, B300		
General Purpose	10A @ 240VAC		

Features:

- DIN rail or surface mountable
- Manual reset option provides last fault detection
- Auto-ranging voltage
- Advanced LED diagnostics
- Adjustable voltage unbalance trip setting
- Adjustable trip & restart delay settings

Approvals:  

Available Models:

460
460-L
460-14
460-575-14
460-15
460-575
460-MR
460-VBM
460-400HZ
460-OEM (bulk packaged - 20 units)
460L-OEM (bulk packaged - 20 units)

3-Phase Voltage Monitor

Model 601

3-phase voltage & frequency monitor, on-board display, adjustable trip delay, optional communications to PLC/SCADA/monitoring systems



The Model 601

is a fully-programmable voltage monitor designed to protect 3-phase motors. It can be used as a stand-alone product or networked with an RM-1000, RM-2000, PLC, computer or SCADA system.

When a harmful condition is detected, the MotorSaver's output relay is deactivated after the specified trip delay. The output relay reactivates after power line conditions return to an acceptable level for the programmed restart delay (RD2).



The following 11 setpoints can be viewed from the 3-digit LED display or from a networked device: low voltage, high voltage, voltage unbalance, low frequency, high frequency, trip delay for voltage/frequency faults, trip delay for single-phase faults, rapid-cycle timer (RD1), restart delay after all faults (RD2), type of restart after all faults (manual or automatic), and RS-485 address. Six parameters can be viewed as the motor is running: L1-L2 voltage, L2-L3 voltage, L1-L3 voltage, average voltage, percent voltage unbalance and frequency.

When used with the RS485MS-2W communications module, the Model 601 can communicate with most modbus RTU master devices. Voltage conditions can be monitored and setpoints can be changed remotely using SymCom's Solutions software, an RM-1000, RM-2000 or other device.

For more information see:
See Appendix A, page 66, Figure 1 for dimensional drawing.
See Appendix B, page 76, Figure 27 for typical wiring diagrams.

Features:

- Protects 3-phase motors from:
 - Loss of any phase (single phasing)
 - Phase reversal
 - Low voltage
 - High voltage
 - Voltage unbalance
 - Low frequency
 - High frequency
 - Rapid cycling
- Built-in 3-digit display for programming, real-time information and diagnostics
- Programmable voltage and frequency settings/parameters
- Programmable restart control (adjustable automatic restart or manual restart)
- Reset pushbutton (and optional remote reset pushbutton)
- 2 each separate programmable trip delay timers and restart delay timers
- Last four faults (with characteristics) available via 3-digit display, network or remote displays
- RS-485 Modbus network communications
- Optional remote displays aid in complying with arc-flash safety regulations

Approvals:   

Auxiliary Products:

- RS485MS-2W (communication module)
- RM-1000/RM-2000 (remote displays)
- 777-MRSW (manual remote reset kit)

Available Models:

601
601-575

Specifications

Input Characteristics

Line Voltage	
601.....	190-480VAC
601-575.....	500-600VAC
Frequency.....	.50/60Hz

Functional Characteristics

Programmable Operating Points

LV - Low Voltage Threshold.....	.170V (450V**) - HV Setting
HV - High Voltage Threshold.....	LV Setting - 528V (660V**)
VUB - Voltage Unbalance Threshold.....	.2-15% or off
LF - Low Frequency Threshold.....	.35Hz - HF Setting
HF - High Frequency Threshold.....	LF Setting - 75Hz

TD1 - Trip Delay for Voltage/ Unbalance/Frequency Faults.....	1-50 seconds
TD2 - Trip Delay for Single-Phase Faults.....	1-50 seconds
RD1 - Rapid-Cycle Timer.....	.0, 2-500 seconds
RD2 - Restart Delay After All Faults.....	2-500 seconds
#RF - Type of Restart.....	Manual or Automatic
ADDR - RS-485 Address.....	A01-A99
Fixed Reset Points	
Overvoltage Reset.....	.97% of HV Setting
Low Voltage Reset.....	.103% of LV Setting
Voltage Unbalance Reset.....	.UB Setting -1%
Low Frequency Reset.....	.LF Setting +0.6Hz
High Frequency Reset.....	.HF Setting -0.6Hz

Output Characteristics

Output Contact Rating	
Pilot Duty.....	.480VA @ 240VAC

General Characteristics

Temperature Range.....	-20° to 70°C (-4° to 158°F)
Accuracy	
Voltage.....	±1%
Timing.....	.5% ±1 second
Repeatability	
Voltage.....	±0.5%
Maximum Input Power.....	.5 W
Transient Protection (Internal).....	.2500 V for 10 ms

Safety Marks

UL.....	UL508 (File #E68520)
CSA.....	C22.2 No. 14 (File #46510)
CE.....	IEC 60947-6-2
Dimensions.....	3.05 H x 3.85 W x 5.05 D in. (77.47 x 97.79 x 128.27 mm)
Weight.....	1.2 lbs. (19.2 oz., 544.31 g)
Mounting Method.....	Surface mount (4 - #8 screws) or DIN rail mount

SymCom's Model 601 can be preprogrammed prior to installation by applying at least 120V to the L1 and L2 terminals.

**575V Model

Single-Phase Voltage Monitors

All of SymCom's single-phase voltage monitors are micro-controller based and are factory calibrated for highly accurate and precise voltage measurements to provide high sensitivity while minimizing nuisance tripping. They are built with transformer power supplies, which makes them highly resistant to damage caused by small voltage transients on the power system. Other types of power supplies such as switching, resistor limited and capacitor limited are typically more easily damaged by transients.

Product Selection Matrix

Model	Low Voltage	High Voltage	Variable Restart Delay	Variable Trip Delay	Manual Reset	DPDT Relay	10 Amp	General Purpose	480VAC @ 240VAC Pilot Duty	OT08 Socket Style	470VA @ 600VAC Pilot Duty	Diagnostic LEDs
50R-100	•											
50R-100-2	•		•		•							•
50R-200	•											•
50R-200-2	•		•		•							•
50R-200-3	•			•								•
50R-200-2-9	•	•	•		•							•
50R-400	•										•	•
50R-400-2	•		•		•						•	•
50R-400-3	•			•							•	•
50R-400-2-9	•	•	•		•						•	•
201-100-SP	•								•			•
201-200-SP	•								•			•
201-200-SP-T-9	•	•							•			•
201-100-SP-DPDT	•					•	•	•	•	•		•
201-200-SP-DPDT	•					•	•	•	•	•		•
202-200-SP	•	•	•		•							•
202-200-SP-NHV	•		•		•							•
460-100-SP	•	•	•									•
460-200-SP	•	•	•									•

••Indicates two relays

Single-Phase Voltage Monitor

single-phase voltage monitor, panel mount, optional high voltage, variable restart or trip delay

Model 50R



The Model 50R

single-phase voltage monitor has a voltage-sensing circuit which constantly monitors the single-phase power for a low voltage condition. Single-phase motors on fans, compressors, air conditioners, heat pumps, well pumps, sump pumps and small conveyor motors are all applicable to the Model 50R.

When a harmful condition is detected, the MotorSaver's output relay is deactivated after a specified trip delay. The output relay reactivates after power line conditions return to an acceptable level and a specified amount of time has elapsed (restart delay). The trip delay prevents nuisance tripping due to rapidly fluctuating power line conditions.

For more information see:

See Appendix A, page 68, Figure 7 for dimensional drawing.



See Appendix B, page 76, Figure 28 for typical wiring diagrams.

Options

- 2 - Variable Restart Delay (Manual, 2-300 seconds)
- 3 - Variable Trip Delay (2-30 seconds)
- 9 - High Voltage Detection

Features:

- Protects against low voltage
- Optional
 - High voltage protection
 - Variable restart delay
 - Variable trip delay

Approvals:  

Available Models:

- 50R-100
- 50R-100-2
- 50R-200
- 50R-200-2
- 50R-200-3
- 50R-200-2-9
- 50R-400
- 50R-400-2
- 50R-400-3
- 50R-400-2-9

Specifications

Input Characteristics

Line Voltage	
50R-100	.95-120VAC
50R-200	.190-240VAC
50R-400	.380-480VAC
Frequency	.50*/60Hz

Functional Characteristics

Low Voltage

Trip (% of setpoint)	.90%
Reset (% of setpoint)	.93%
Delay Time (Nominal)	
Trip	.4 seconds
Restart (low voltage)	.2 seconds
Restart (complete power loss)	.2 seconds

Output Characteristics

Output Contact Rating (SPDT - 1 Form C)	
50R-100, 50R-200	
Pilot Duty	.480VA @ 240VAC
General Purpose	.10A @ 240VAC
50R-400	
Pilot Duty	.470VA @ 600VAC

General Characteristics

Ambient Temperature Range	
Operating	-.20° to 70°C (-4° to 158°F)
Storage	-.40° to 80°C (-40° to 176°F)
Maximum Input Power	.5 W
Relative Humidity	.10-95%, non-condensing per IEC 68-2-3
Terminal	
Torque	.7 in.-lbs.
Wire Size	.12-18AWG
Electrostatic Discharge (ESD)	.IEC 61000-4-2, Level 3, 6kV contact, 8kV air
Fast Transient Burst	.IEC 61000-4-4, Level 3, 3.5kV input power and controls
Transient Protection (Internal)	.IEC 61000-4-5; 1995 ±6kV
Safety Marks	
UL	.UL508 (File #E68520)
CE	.IEC 60947-6-2
Dimensions	.2.93"H x 5.27"W x 2.95"D (74.4 x 133.9 x 74.9mm)
Weight	.0.98 lb. (15.68 oz., 444.52 g)
Mounting Method	.#8 screws

Special Options

Option 2 - Variable Restart Delay	.Manual, 2-300 seconds
Option 3 - Variable Trip Delay	.2-30 seconds
Option 9 - High Voltage Detection Operating Points	
Trip (% of Setpoint)	.110%
Reset (% of Setpoint)	.107%

*Note: 50Hz will increase all delay timers by 20%



Must use Model OT08 socket for UL Rating!

The Model 201-xxx-SP

is an 8-pin octal-base, plug-in voltage monitor designed to protect single-phase motors regardless of size. The 201-100-SP is used on 95-120VAC, 50/60Hz motors to prevent damage caused by low voltage. The Model 201-200-SP is used on 190-240VAC, 50/60Hz motors. The 201-200-SP-T-9 is a pin-for-pin replacement for a Time Mark® #260 Series voltage monitor. High voltage protection is included in the 201-200-SP-T-9.

The unique microcontroller-based voltage and voltage-sensing circuit constantly monitors the voltage to detect harmful power line conditions. When a harmful condition is detected, the MotorSaver's output relay is deactivated after a specified trip delay. The output relay reactivates after power line conditions return to an acceptable level and a specified amount of time has elapsed (restart delay). The trip delay prevents nuisance tripping due to rapidly fluctuating power line conditions.



For more information see:

See Appendix A, page 68, Figure 8 for dimensional drawing.

See Appendix B, page 76, Figure 29 for typical wiring diagrams.

Features:

- Low voltage protection
- Diagnostic LED
- 8-pin plug in; DIN rail or surface mount

Approvals:  

Auxiliary Products:

- 8-pin octal socket (P/N: CTOT08-PC)

Available Models:

- 201-100-SP
- 201-200-SP
- 201-200-SP-T-9

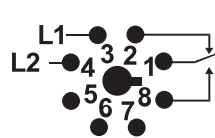

Pin-out 1
(201-xxx-SP)
(view of socket)

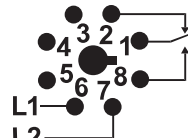

Pin-out 2
(201-200-SP-T-9)
(view of socket)

Specifications

Input Characteristics

Line Voltage	
201-100-SP	95-120VAC
201-200-SP, 201-200-SP-T-9	190-240VAC
Frequency	50/60Hz

Functional Characteristics

Low Voltage (% of setpoint)	
Trip	90%
Reset	93%
For 201-200-SP-T-9 only: High Voltage (% of setpoint)	
Trip	110%
Reset	107%
Trip Delay Time	
High/Low Voltage Fault	4 seconds
Restart Delay Time	
After a Fault	2 seconds
After a Complete Power Loss	2 seconds

Output Characteristics

Output Contact Rating (SPDT)	
Pilot Duty	480VA @ 240VAC
General Purpose	10A @ 240VAC

General Characteristics

Ambient Temperature Range	
Operating	-40° to 70°C (-40° to 158°F)
Storage	-40° to 80°C (-40° to 176°F)
Maximum Input Power	5 W
Transient Protection (Internal)	2500V for 10 ms
Safety Marks	
UL (OT08 octal socket required)	UL508 (File #E68520)
CE	IEC 60947-6-2
Dimensions	1.750" H x 2.375" W x 4.125" D (with socket) (44.45 x 60.325 x 104.775mm)
Weight	0.8 lb. (12.8 oz., 362.87 g)
Mounting Method	DIN rail or surface mount (plug in to OT08 socket)

Socket Available Model # OT08 (UL Rating 600V)
The 600V socket can be surface mounted or installed on DIN Rail.

Single-Phase Voltage Monitor

single-phase voltage/phase monitor, 8-pin socket mount, two isolated Form C relays

Model 201-xxx-SP-DPDT



Must use Model OT08 socket for UL Rating!

The Model 201-xxx-SP-DPDT

is an 8-pin octal-base, plug-in voltage monitor designed to protect single-phase motors regardless of size. The 201-100-SP-DPDT is used on 95-120VAC, 50/60Hz motors to prevent damage caused by low voltage. The 201-200-SP-DPDT is used on 190-240VAC, 50/60Hz motors. The units feature two isolated sets of contacts that are ideal for use with two control circuits with different voltages.

The unique microcontroller-based voltage and voltage-sensing circuit constantly monitors the voltage to detect harmful power line conditions. When a harmful condition is detected, the MotorSaver's output relays are deactivated after a specified trip delay. The output relays reactivate after power line conditions return to an acceptable level and a specified amount of time has elapsed (restart delay). The trip delay prevents nuisance tripping due to rapidly fluctuating power line conditions.



For more information see:

See Appendix A, page 68, Figure 8 for dimensional drawing.

See Appendix B, page 76, Figure 30 for typical wiring diagrams.

Features:

- Low voltage protection
- Two isolated Form C relays (DPDT)
- Diagnostic LED
- 8-pin plug-in; DIN rail or surface mount

Approvals:  

Auxiliary Products:

- 8-pin octal socket (P/N: CT0T08-PC)

Available Models:

201-100-SP-DPDT
201-200-SP-DPDT

Specifications

Input Characteristics

Line Voltage	
201-100-SP-DPDT	.95-120VAC
201-200-SP-DPDT	.190-240VAC
Frequency	.50/60Hz

Functional Characteristics

Low Voltage (% of setpoint)	
Trip	.90% $\pm 1\%$
Reset	.93% $\pm 1\%$
Trip Delay Times	
Low Voltage	.4 seconds
Restart Delay Times	
After a Fault or Complete Power Loss	.2 seconds

Output Characteristics

Output Contact Rating (DPDT)	
Pilot Duty	.480VA @ 240VAC
General Purpose	.10A @ 240VAC

General Characteristics

Ambient Temperature Range	
Operating	-.20° to 70°C (-4° to 158°F)
Storage	-.40° to 80°C (-40° to 176°F)
Maximum Input Power	.5 W
Relative Humidity	.10-95%, non-condensing per IEC 68-2-3
Standards Passed	
Electrostatic Discharge (ESD)	.IEC 61000-4-2, Level 3, 6kV contact, 8kV air
Radio Frequency Immunity, Radiated	.150MHz, 10V/m
Fast Transient Burst	.IEC 61000-4-4, Level 3, 3.5kV input power and controls
Safety Marks	
UL (OT08 octal socket required)	.UL508 (File #E68520)
CE	.IEC 60947-6-2
Dimensions	.1.750" H x 2.375" W x 4.125" D (with socket) (44.45 x 60.325 x 104.775mm)
Weight	.0.65 lb. (10.4 oz., 294.84 g)
Mounting Method	.DIN rail or surface mount (plug in to OT08 socket)

3-Phase Voltage Monitor

single-phase voltage monitor, panel mount, adjustable or manual restart delay

Model 202-200-SP



The Model 202-200-SP

voltage monitor is designed to protect single-phase motors regardless of size. It can be used with 190V-240VAC, 50/60Hz motors to prevent damage caused by incoming power problems.

A unique microcontroller-based voltage-sensing circuit constantly monitors the voltage to detect harmful power line conditions. When a harmful condition is detected, the MotorSaver's output relay is deactivated after a specified trip delay. The output relay reactivates after power line conditions return to an acceptable level and a specified amount of time has elapsed (restart delay). The trip delay prevents nuisance tripping due to rapidly fluctuating power line conditions.

For more information see:

See Appendix A, page 68, Figure 9 for dimensional drawing.

See Appendix B, page 77, Figures 31 & 32 for typical wiring diagrams.

Features:

- Protects from high and low voltage (low voltage only for 202-200-SP-NHV)
- Protects against rapid cycling
- Quick mounting with single screw
- Adjustable restart delay setting
- Small package, ideal for assembly into panels
- Standard 1/4" quick connects

Approvals: 

Available Models:

202-200-SP
202-200-SP-NHV

Specifications

Input Characteristics

Line Voltage	
202-200-SP, 202-200-SP-NHV	.190-240VAC
Frequency	.50*/60Hz

Functional Characteristics

Low Voltage (% of setpoint)

Trip	.90%
------	------

Reset	.93%
-------	------

High Voltage (% of setpoint) (Not available on -NHV model)

Trip	.110%
------	-------

Reset	.107%
-------	-------

Trip Delay Time

High and Low Voltage	.4 seconds
----------------------	------------

Restart Delay Time

After a fault or complete power loss	.Manual, 2-300 seconds adj.
--------------------------------------	-----------------------------

Output Characteristics

Output Contact Rating (SPDT)

Pilot Duty	.480VA @ 240VAC
------------	-----------------

General Purpose	.10A @ 240VAC
-----------------	---------------

General Characteristics

Temperature Range	-.40° to 70°C (-40° to 158°F)
-------------------	-------------------------------

Trip & Reset Accuracy	±1%
-----------------------	-----

Repeatability	±0.5%
---------------	-------

Input to Output Dielectric	.1960 Vrms (min.)
----------------------------	-------------------

Termination	.0.25" male quick connect
-------------	---------------------------

Maximum Input Power	.5 W
---------------------	------

Relative Humidity	.95%, non-condensing
-------------------	----------------------

Transient Protection	.IEC 61000-4-5, ±4kV
----------------------	----------------------

Safety Marks

UL, UL Recognized	.UL508 (File #E68520)
-------------------	-----------------------

Dimensions	.2.5" H x 2.5" W x 1.4" D (63.5 x 63.5 x 35.56mm)
------------	--

Weight	.0.5 lb. (8 oz., 226.8 g)
--------	---------------------------

Mounting Method	.1/4" socket head cap screw (customer supplied)
-----------------	--

*Note: 50Hz will increase all delay timers by 20%.

Single-Phase Voltage Monitor

single-phase voltage monitor, din rail mount, adjustable restart delay

Model 460-xxx-SP



The Model 460-100-SP

is used on 95-120VAC, 50*/60Hz single-phase motors and the 460-200-SP is used on 190-240VAC, 50*/60Hz single-phase motors to protect them from damaging high and low voltage conditions. An adjustment knob allows the user to set a 1-500 second restart delay. The variable restart delay is also a power-up delay and can be utilized to stagger-start motors on the same system.

A unique microcontroller-based, voltage-sensing circuit constantly monitors the voltage to detect harmful power line conditions. When a harmful condition is detected, the MotorSaver's output relay is deactivated after a specified trip delay. The output relay reactivates after power line conditions return to an acceptable level and a specified amount of time has elapsed (restart delay). The trip delay prevents nuisance tripping due to rapidly fluctuating power line conditions.

For more information see:

See Appendix A, page 69, Figure 11 for dimensional drawing.

See Appendix B, page 77, Figure 33 for typical wiring diagrams.

Features:

- Protects from low and high voltage, and rapid cycle
- DIN rail or surface mountable
- LED Diagnostics
- Adjustable restart delay setting

Approvals:  

Available Models:

460-100-SP
460-200-SP

Specifications

Input Characteristics

Line Voltage	95-120VAC
460-100-SP	190-240VAC
460-200-SP	190-240VAC
Frequency	50*/60Hz

Functional Characteristics

Low Voltage (% of setpoint)	
Trip	90% ±1%
Reset	93% ±1%
High Voltage (% of setpoint)	
Trip	110% ±1%
Reset	107% ±1%
Trip Delay Time	
Low or High Voltage	4 seconds fixed
Restart Delay Time	
After a Fault	1-500 seconds adjustable
After a Complete Power Loss	1-500 seconds adjustable
Output Characteristics	
Output Contact Rating (1 Form C)	
Pilot Duty	480VA @ 240VAC, B300
General Purpose	10A @ 240VAC
General Characteristics	
Ambient Temperature Range	
Operating	-40° to 70°C (-40° to 158°F)
Storage	-40° to 80°C (-40° to 176°F)
Maximum Input Power	.6 W

Class of Protection	IP20, NEMA 1 (finger safe)
Relative Humidity	10-95%, non-condensing per IEC 68-2-3
Terminal Torque	.6 in.-lbs.
Wire Type	Stranded or solid 12-20 AWG, one per terminal
Standards Passed	
Electrostatic Discharge (ESD)	IEC 61000-4-2, Level 3, 6kV contact, 8kV air
Radio Frequency Immunity	
Radiated	150 MHz, 10V/m
Fast Transient Burst	IEC 61000-4-4, Level 3, 3.5 kV input power & controls
Surge	
IEC	IEC 61000-4-5, Level 3, 4kV line-to-line; Level 4, 4kV line-to-ground
ANSI/IEEE	C62.41 Surge and Ring Wave Compliance to a level of 6kV line-to-line
Hi-potential Test	Meets UL508 (2 x rated V +1000V for 1 min)
Safety Marks	
UL	UL508 (File #E68520)
CE	IEC 60947-6-2
Enclosure	Polycarbonate
Dimensions	3.5" H X 2.084" W X 2.350" D (88.9 x 52.93 x 59.69mm)
Weight	0.9 lb. (14.4 oz., 408.23 g)
Mounting Method	35mm DIN rail or Surface Mount (#6 or #8 screws)

*Note: 50 Hz will increase all delay timers by 20%

Current Monitors

Current Monitors have many advantages over voltage monitors because they provide protection against both supply line and load side faults when the motor is running. They protect against single-phasing and current unbalance problems that can be caused by voltage supply problems, bad contactors, loose wiring, bad wires or damaged motors. They also provide very reliable overload and underload protection.

Current monitors are used to detect heater element failure, loss of load, peak power loads, runaway and radio tower light failure, feed rate, dull bits and blades, conveyor load jams, current demand level and to keep tooling loads at their most efficient point.

Product Selection Matrix

MODEL	Phase Loss	Phase Reversal	Undercurrent	Overcurrent	Current Unbalance	Rapid Cycling	Diagnostic Display	Trip Delay	RD1 Rapid-Cycle Timer	RD2 Overcurrent Restart Delay Timer	RD3 Undercurrent Restart Delay Timer	#RF Number of Restarts After All Faults (except UC fault*)	#RU Number of Restarts After an UC Fault	Motor Acceleration Time	Remote Manual Reset
520CS-115	•	•	•	•	•	•	•	•	•	•	•	•	•	•	•
520CP-115	•	•	•	•	•	•	•	•	•	•	•	•	•	•	•
520CP-230	•	•	•	•	•	•	•	•	•	•	•	•	•	•	•
520CP-460	•	•	•	•	•	•	•	•	•	•	•	•	•	•	•

* Includes UC fault on 520CS units



The Model 520CS

is a fully-programmable, microcontroller-based, current-sensing device designed to monitor 3-phase pumps. Unlike the Model 520CP which is designed to work with motors that have ramp-up times of 4 seconds or less, the Model 520CS has a programmable motor acceleration time that can be set from 0-50 seconds.



Three external current transformers must be utilized in conjunction with the Model 520CS. The following nine parameters can be set and viewed from the 3-digit alphanumeric display: overcurrent trip point, undercurrent trip point, current unbalance trip point, trip delay, rapid-cycle timer (RD1), overload restart delay (RD2), underload restart delay (RD3), number of starts after a fault and motor acceleration time. Last fault diagnostic is also viewable. When a harmful condition is detected, the MotorSaver's output relay is deactivated after the specified trip delay. The output relay reactivates after the appropriate RD2 or RD3 timer has expired. Overcurrent, undercurrent and current unbalance are ignored during the motor acceleration period; however, if the motor is started on a single-phase or a reverse-phase condition, the Model 520CS deactivates its output relay in 0.5 second.

For more information see:
See Appendix A, page 69, Figure 12 for dimensional drawing.
See Appendix B, page 77, Figure 34 for typical wiring diagrams.

RD1 - restart delay on power-up and rapid-cycle timer
RD2 - restart delay after all faults except undercurrent
RD3 - restart delay after undercurrent

Features:

- Motor acceleration trip delay
- Protects three-phase motors from:
 - Overcurrent
 - Undercurrent
 - Current unbalance
 - Rapid cycling
 - Single phasing
 - Phase reversal

Approvals:  

Available Models:

520CS-115

Specifications

Input Characteristics	
Control Voltage	100-130VAC
Frequency	50*/60Hz
Functional Characteristics	
Maximum Full Scale Current	5 Amps (max.)
Fixed Operating Points	
Reverse-Phase Trip Delay	0.5 second
Single-Phase Trip Delay	0.5 second
Output Characteristics	
Output Contact Rating (SPDT)	480VA at 240VAC
Pilot Duty	10A
General Purpose	10A
General Characteristics	
Temperature Range	0° to 70°C (32° to 158°F)
Repeat Accuracy Trip Point	±2%
Repeat Accuracy Timing	±25%, ±1 second
Maximum Input Power	5 W
Transient Protection (Internal)	2500V for 10 ms
Safety Marks	
UL	UL508 (File #E68520)
CSA	C22.2 (File #46510)
Dimensions	8.25" H x 5.25" W x 3.25" D (209.55 x 133.35 x 82.55mm)
Weight	2.2 lbs. (35.2 oz., 997.9 g)
Mounting Method	Four #10 or #12 screws (3/4"-1" in length)

*Note: 50Hz will increase all delay timers by 20%

Requires external current transformers (sold separately).

3-Phase Voltage Monitor

Model 520CP

3-phase current monitor, for use with motors having ramp up times of 4 seconds or less, second relay optional on 115VAC version



The Model 520CP

is a fully-programmable, microcontroller-based, current-sensing device designed to monitor 3-phase pumps or systems with ramp-up times of 4 seconds or less. Applications include submersible pumps, booster pumps, reverse osmosis systems, centrifugal pumps, vertical turbine pumps, oil well pumps, chemical pumps or other similar systems.

Three external current transformers must be utilized in conjunction with the Model 520CP. The following nine setpoints can be set and viewed from the 3-digit alphanumeric display: overcurrent trip point, undercurrent trip point, current unbalance trip point, trip delay, rapid-cycle timer (RD1), overload restart delay (RD2), underload restart delay (RD3), number of starts after an overload and number of restarts after an underload fault. Last

fault diagnostic is also viewable. When a harmful condition is detected, the MotorSaver's output relay is deactivated after the specified trip delay. The output relay reactivates after the appropriate RD2 or RD3 timer has expired. If the pump is started on a single-phase or a reverse-phase condition, the Model 520CP deactivates its output relay in 0.5 second.

520CP-115-RX-30 - The 520CP unit has two output relays that work independently of each other. The right relay energizes on start up and the left relay energizes on a fault after all restart attempts are exhausted. (RD1 in minutes)

520CP-115-RX-56 - This 520CP unit has two output relays that work in unison. Unit displays 'nc' (no current) when the current of the motor equals '0' for more than 4 seconds. (RD1 in minutes)

For more information see:

See Appendix A, page 69, Figure 12 for dimensional drawing.

See Appendix B, page 77, Figure 34 for typical wiring diagrams.

RD1 - restart delay on power-up and rapid-cycle timer

RD2 - restart delay after all faults except undercurrent

RD3 - restart delay after undercurrent

Features:

- Protects three-phase motors from:
 - Overcurrent
 - Undercurrent
 - Current unbalance
 - Rapid cycling
 - Single phasing
 - Phase reversal

Approvals:   

Available Models:

520CP-115
520CP-230
520CP-460
520CP-115-RX-30
520CP-115-RX-56

Specifications

Input Characteristics

Control Voltage

520CP-115100-130VAC

520CP-230200-250VAC

520CP-460400-500VAC

Frequency50*/60Hz

Functional Characteristics

Maximum full scale current5 Amps (max.)

Fixed Operating Point

Reverse & Single-Phase Trip Delay0.5 second

Trip Point Accuracy±2%

Timing Accuracy±25%, ±1 second

Temperature Range0° to 70°C

Output Characteristics

Output Contact Rating (SPDT)

520CP-115, 520CP-230480VA @ 240VAC

General Purpose10A

520CP-460

Pilot Duty470VA @ 600VAC

General Characteristics

Temperature Range0° to 70°C (32° to 158°F)

Maximum Input Power5 W

Transient Protection (Internal)2500V for 10 ms

Safety Marks

ULUL508 (File #E68520)

CSAC22.2 (File #46510)

Dimensions8.25" H x 5.25" W x 3.25" D

(209.55 x 133.35 x 82.55mm)

Weight2.2 lbs. (35.2 oz., 997.9 g)

Mounting MethodFour #10 or #12 screws (3/4"-1" in length)

Options (additional cost)DPDT Relay Contacts

*Note: 50Hz will increase all delay timers by 20%

Requires external current transformers (sold separately).

Pump Controllers

Pump Controllers are innovative products for controlling a single pump or multiple pumps. Some models can be used to detect pump seal leaks and motor overheating on submersible pumps. Other models can be used as a five-channel pump controller or five-channel switch to support all popular industry standard multi-pump configurations.

Product Selection Matrix

MODEL	UL508	Isolated Relays	1 Input	2 Inputs	5 Inputs	4.7 - 100 k	10 k	Adjustable	Fixed	Form C Isolated Relay	Form C Relay	Form A Relay	Selectable Inverted Logic	Duplex	Triplex	Quadplex	Simplex
PC-102-CICI-DL	•	•		•		•		••				•	•				
PC-102-CICI-LT	•	•		•		•		••				•	•				
PC-105	•	•			•		•			•	•*	•	•	•	•		
PC-100-LLC-CZ	•			•		•		•	•	•							
PC-200-LLC-CZ	•			•		•		•	•	•							
PC-100-LLC-GM	•			•		•		•	•	•							
PC-200-LLC-GM	•			•		•		•	•	•							
460-15-100-LLS	•		•			•				••							•
460-15-100-SLD	•		•			•				••	•						•
201-100-SLD	•		•			•		•	•								•

* Denotes 4 relays
 •• Denotes 2 relays

MODEL	Duplex Pumping	DPDT	Manual Switch
ALT-(xxx)-S	•		
ALT-(xxx)-S-SW	•		•
ALT-(xxx)-X	•		
ALT-(xxx)-X-SW	•		•
ALT-100-1-SW	•	•	•
ALT-200-1-SW	•	•	•
ALT-100-3-SW	•		•
ALT-200-3-SW	•		•
50R-400-ALT	•		•

Pump Controller

either a dual seal-leak detector (-DL) or seal-leak & over-temperature detector (-LT),
adjustable seal-leak sensitivity

Model PC-102



The PC-102

-DL is a dual seal-leak detector. The inputs are used to sense seal failures on pumps. When water is detected, the associated output relay is energized. The input logic may be selected to be direct or inverted by using DIP switches on the side of the device.

-LT is a seal-leak and over-temperature detector. The seal-leak input is used to sense seal failures on submersible pumps while the temperature input is used to detect motor overheating. Both can be configured to suit the probes of your choice. DIP switches on the side of the unit allows the operator to select direct logic or inverted logic for the seal input, and to configure the unit for automatic or manual reset after an over-temperature trip.

Both units have two form-C isolated output relays and two LEDs, which illuminate when each associated output relay is energized.

The sensitivity adjustment (4.7k-100kOhms) allows you to define the input impedance at which the output relays will change state. The sensitivity for the over-temperature detector can be set to 4k Ohms with use of the DIP switches.

This unit may not be compatible with Flygt pumps.

For more information see:

See Appendix A, page 69, Figure 11 for dimensional drawing.

See Appendix B, page 78, Figures 35 & 36 for typical wiring diagrams.

Features:

- Compact design
- Finger-safe terminals
- DIN rail or surface mountable
- Two Form C isolated contacts with LED status indicators
- Invertible relay logic
- Configurable over-temperature reset (PC-102CICI-LT)

Approvals: 

Available Models:

PC-102CICI-DL
PC-102CICI-LT

Specifications

Input Characteristics	
Supply Voltage	120VAC nominal
Frequency	50/60Hz
Functional Characteristics	
Probe Sense Voltage	5vdc pulsed
Sensitivity	4.7k-100kΩ
Sensitivity (for temp)	Selectable 4kΩ with DIP switches
Input Logic	Direct or inverted
Debounce Time Delay	0.5 or 2 seconds
Output Characteristics	
Relay Output Rating (2 Form C isolated)	
Pilot Duty	180VA @ 120VAC, C150
General Purpose	5A @ 240VAC
General Characteristics	
Temperature Range	-20° to 55°C (-4° to 131°F)
Maximum Input Power	2 W
Depluggable Connector	Phoenix Contact-Series MSTB plugs

Output Relay Status Indicators	LEDs
Terminal Torque	.6 in.-lbs.
Wire range	12-20 AWG
Standards Passed	
Electrostatic Discharge (ESD)	IEC 61000-4-2, Level 3, 6kV contact, 8kV air.
Radio Frequency Immunity (RFI)	IEC 61000-4-3, Level 3, 10V/m
Fast Transients	IEC 61000-4-4, Level 3, 4kV input power 2kV inputs/outputs
Safety Marks	
UL	UL508 (File #E68520)
Dimensions	3.5" H X 2.084" W X 2.350" D (88.9 x 52.93 x 59.69mm)
Weight	0.9 lb. (14.4 oz., 408.23 g)
Mounting Method	35mm DIN rail or Surface Mount (#6 or #8 screws)



The PC-105

is a 5-channel pump controller designed to handle multiple pump applications. Alternatively, it can operate as a 5-channel switch.

The PC-105's control functions support all of the popular industry-standard multi-pump pump-up and pump-down configurations.

It can indicate low, high and out-of-sequence alarms and use alternating and non-alternating pump control. The non-alternating pump can be used as a jockey pump or emergency pump.

Using the built-in DIP switches, individual pumps can be disabled when taken out of service for repair or maintenance.

For more information see:
See Appendix A, page 70, Figure 13 for dimensional drawing.

Features:

- Low, high and out-of-sequence alarms
- Variable time delay / lag pump delay from 2-255 seconds
- Duplex SPS (separate pump stop) pump control
- Duplex, triplex or quadplex pump control
- Pump-up or pump-down functions
- External silence, reset and alternation configuration
- Five-channel relay configuration
- DIN rail or surface mountable

Approvals: 

Available Models:

PC-105

Specifications

Input Characteristics	
Supply Voltage	120VAC
Frequency	50*/60Hz
Output Characteristics	
Relay Output Rating	
Pilot Duty480VA @ 240VAC, B300
General Purpose7A @ 240VAC
General Characteristics	
Temperature Range	-20° to 55°C (-4° to 131°F)
Maximum Input Power4 W
Wire range12 to 20 AWG
Terminal Torque6 in.-lbs. (max.)
Pump In-rush delay2 seconds
Standards Passed	
Electrostatic Discharge (ESD)	IEC 61000-4-2, Level 3, 6kV contact, 8kV air.
Radio Frequency Immunity (RFI)	IEC 61000-4-3, Level 3, 10V/m
Fast Transients	IEC 61000-4-4, Level 3, 4kV input power 2kV inputs/outputs
Safety Marks	
UL	UL508 (File #E68520)
Dimensions	3.703" W x 5.025" L x 2.35" H (94.06 x 127.64 x 59.69mm)
Weight	1.2 lbs. (19.2 oz., 544.31 g)
Mounting Method35 mm DIN rail or Surface Mount (#6 or #8 screws)

*Note: 50Hz will increase all delay timers by 20%.



Must use Model OT08 socket for UL Rating!

The PC-xxx-LLC-CZ & PC-xxx-LLC-GM are liquid level control relays used to control conductive liquid pumping operations in a pump-up or pump-down application. The units come in two different voltage ranges (see specs below).

The units have an adjustable sensitivity knob (4.7k to 100k ohms) that is set according to the resistance level at which you want the probes (sold separately) to sense the conductive liquid. The units have a built-in debounce time delay that prevents the relay from energizing if the probe resistance momentarily goes above or below the sensitivity setpoint (due to liquid splashing in the tank).



The units operate their internal relay based on inputs from a high and low probe and a common reference (when a conductive tank is used) or common probe (when a non-conductive tank is used).

For more information see:
See Appendix A, page 68, Figure 8 for dimensional drawing.
See Appendix B, page 78, Figures 37 & 38 for typical wiring diagrams.

- PC-xxx-LLC-GM
- Compatible with Gems' Series 16M general purpose control
- PC-xxx-LLC-CZ
- Compatible with Crouzet's PNR & PNRU series liquid level control

Features:

- One unit serves pump-up and pump-down applications
- Adjustable sensitivity knob (4.7 to 100Kohms)
- Debounce time delay (2 seconds)
- Single or dual probe inputs (plus a common reference)

Approvals:  

Auxiliary Products:

- 8-pin octal socket (P/N: CT0T08-PC)

Available Models:

- PC-100-LLC-CZ
- PC-200-LLC-CZ
- PC-100-LLC-GM
- PC-100-LLC-GM-OT (sold with OT08 socket)
- PC-200-LLC-GM
- PC-200-LLC-GM-OT (sold with OT08 socket)

Specifications

Input Characteristics		Standards Passed	
Supply Voltage		Electrostatic Discharge (ESD)	IEC 61000-4-2, Level 3, 6kV contact, 8kV air.
PC-100-LLC-CZ, PC-100-LLC-GM	95-120VAC	Radio Frequency Immunity (RFI)	.150MHz, 10V/m
PC-200-LLC-CZ, PC-200-LLC-GM	190-240VAC	Fast Transients	IEC 61000-4-4, Level 3, 2kV input power and controls
Frequency	50/60Hz	Safety Marks	
Functional Characteristics		UL (OT08 octal socket required)	UL508 (File #E68520)
Probe Sense Voltage	5vdc pulsed	CE	IEC60947-6-2
Debounce Time Delay	2 seconds	Dimensions	1.75" H x 2.375" W x 4.125" D (44.45 x 60.33 x 104.78mm)
Probe Sensitivity	4.7k to 100k Adjustable	Weight	0.65 lb. (10.4 oz., 294.84 g)
Output Characteristics		Mounting Method	DIN rail or surface mount (plug into OT08 socket)
Output Contact Rating		Socket Available	Model OT08 (UL Rating 600V) The 600V socket can be surface mounted or installed on DIN Rail.
Pilot Duty	480VA @ 240VAC		
General Purpose	10A @240VAC		
General Characteristics			
Temperature Range	-40° to 70°C (-40° to 158°F)		
Maximum Input Power	5 W		



The Model 460-15-100-LLS

is a liquid level sensor to detect the presence of conductive liquids. A probe is mounted at the desired tank level and connected to the PumpSaver®. When the probe is submersed, the PumpSaver's output contacts will change state as soon as the debounce time expires. The adjustable debounce timer is intended to prevent nuisance actuating due to waves or splashing in the tank.

Relay logic can be inverted so the PumpSaver's output contacts change state when the probe is no longer submersed. This makes the unit versatile for use in pump-up and pump-down applications.



For more information see:

See Appendix A, page 69, Figure 11 for dimensional drawing.

See Appendix B, page 79, Figure 39 for typical wiring diagrams.

Features:

- DIN rail or surface mountable
- Unique probe protection algorithm
- Invertible relay logic for use in pump-up and pump-down applications
- Adjustable debounce timer
- Microcontroller based
- 2 relay contacts
- LED status indicators

Approvals:  

Available Models:

460-15-100-LLS

Specifications

Input Characteristics	
Control Voltage	.110/120VAC nominal
Frequency	.50*/60Hz
Sensitivity	.100kΩ
Functional Characteristics	
Probe Sense Voltage	.5vdc pulsed
Debounce Time Delay	.2-60 seconds
Output Characteristics	
Output contact Rating – (Two Form A - DPST)	
Pilot Duty	.360VA @ 240VAC
General Purpose	.8A @ 240VAC
General Characteristics	
Ambient Temperature Range	
Operating	-.40° to 70°C (-40° to 158°F)
Storage	-.40° to 80°C (-40° to 176°F)
Maximum Input Power	.2 W
Class of Protection	.IP20, NEMA 1 (finger safe)
Relative Humidity	.10-95%, non-condensing per IEC 68-2-3
Terminal Torque	.6 in.-lbs.
Wire	.12-20 AWG
Standards Passed	
Electrostatic Discharge (ESD)	.IEC 61000-4-2, Level 3, 6kV contact, 8kV air
Radio Frequency Immunity, Radiated	.150MHz, 10 V/m
Fast Transient Burst IEC	.61000-4-4, Level 3, 3.5kV input power and controls

Surge	
IEC	.IEC 61000-4-5, Level 3, 4kV line-to-line; Level 4, 4kV line-to-ground
ANSI/IEEE	.C62.41 Surge and Ring Wave Compliance to a level of 6kV line-to-line
Hi-Potential Test	.Meets UL508 (2 x rated V + 1000 V for 1 min.)
Safety Marks	
UL	.UL508 (File #E68520)
CE	.IEC 60947
Enclosure	.Polycarbonate
Dimensions	.3.5" H X 2.084" W X 2.350" D (88.9 x 52.93 x 59.69mm)
Weight	.1 lb. (16 oz., 453.59 g)
Mounting Method	.35mm DIN rail or Surfact Mount (#6 or #8 screws)

*Note: 50Hz will increase all delay timers by 20%



The Model 460-15-100-SLD

is a seal-leak detector to sense seal failures on submersible pumps. A microcontroller-based relay that monitors the shaft seal of a submersible pump motor. A resistive probe is installed in the seal cavity. If water leaks into the pump, the resistance measured by the probe decreases. When the resistance drops below the sensitivity setpoint, the unit will trip and the relay contacts will change state. Output relay logic can be reversed by removing an external jumper. The unit will automatically reset when a fault is cleared.



For more information see:

See Appendix A, page 69, Figure 11 for dimensional drawing.

See Appendix B, page 79, Figure 40 for typical wiring diagrams.

Features:

- DIN rail or surface mountable
- Unique probe protection algorithm
- Invertible relay logic
- 4.7k to 100kΩ adjustable sensitivity
- Microcontroller based
- 2 relay contacts
- LED status indicator

Approvals:  

Available Models:

460-15-100-SLD

Specifications

Input Characteristics		
Control Voltage	110/120VAC nominal
Frequency	50*/60Hz
Functional Characteristics		
Sensitivity	4.7k-100kΩ
Output Characteristics		
Output contact Rating - (Two Form A - DPST)		
Pilot Duty360VA @ 240VAC
General Purpose8A @ 240VAC
General Characteristics		
Ambient Temperature Range		
Operating	-40° to 70°C (-40° to 158°F)
Storage	-40° to 80°C (-40° to 176°F)
Maximum Input Power2 W
Class of ProtectionIP20, NEMA 1 (finger safe)
Relative Humidity10-95%, non-condensing per IEC 68-2-3
Terminal Torque6 in.-lbs.
WireAWG 12-20 AWG
Standards Passed		
Electrostatic Discharge (ESD)IEC 61000-4-2, Level 3, 6kV contact, 8kV air
Radio Frequency Immunity, Radiated150MHz, 10 V/m
Fast Transient Burst IEC61000-4-4, Level 3, 3.5kV input power and controls
Surge		
IECIEC 61000-4-5, Level 3, 4kV line-to-line; Level 4, 4kV line-to-ground
ANSI/IEEEC62.41 Surge and Ring Wave Compliance to a level of 6kV line-to-line
Hi-Potential TestMeets UL508 (2 x rated V + 1000 V for 1 min.)
Safety Marks		
ULUL508 (File #E68520)
CEIEC 60947
EnclosurePolycarbonate
Dimensions3.5"H x 2.084"W x 2.35"D (88.9 x 52.93 x 59.69mm)
Weight1 lb. (16 oz., 453.59 g)
Mounting Method35mm DIN rail or Surfact Mount (#6 or #8 screws)
*Note: 50Hz will increase all delay timers by 20%		

Seal-Leak Detector

single-channel seal-leak detector, 8-pin socket mount, adjustable sensitivity point

Model 201-100-SLD



The Model 201-100-SLD

is an 8-pin plug-in style seal-leak detector to sense seal failures on submersible pumps. A microcontroller-based relay that monitors the shaft seal of a submersible pump motor. A resistive probe is installed in the seal cavity. If water leaks into the pump, the resistance measured by the probe decreases. When the resistance drops below the sensitivity setpoint, the unit will trip and the relay contacts will change state. The unit will automatically reset when a fault is cleared.

For more information see:

See Appendix A, page 68, Figure 8 for dimensional drawing.

See Appendix B, page 79, Figure 41 for typical wiring diagrams.

Features:

- LED status indicator
- Compact plug-in design
- DIN rail or surface mountable via octal base

Approvals:  

Auxiliary Products:

- 8-pin octal socket (P/N: CT0T08-PC)

Available Models:

201-100-SLD

Must use Model OT08 socket for UL Rating!

Specifications

Input Characteristics	
Control Voltage	110/120VAC nominal
Frequency	50/60Hz
Functional Characteristics	
Sensitivity	4.7k-100kΩ
Output Characteristics	
Output contact Rating - SPDT	
Pilot Duty	480VA @240VAC
General Purpose	10A @240VAC
General Characteristics	
Ambient Temperature Range	
Operating	-40° to 70°C (-40° to 158°F)
Storage	-40° to 80°C (-40° to 176°F)
Maximum Input Power	5 W
Relative Humidity	10-95%, non-condensing per IEC 68-2-3
Standards Passed	
Electrostatic Discharge (ESD)	IEC 61000-4-2, Level 3, 6kV contact, 8kV air
Radio Frequency Immunity, Radiated	150MHz, 10V/m
Fast Transient Burst	61000-4-4, Level 3, 3.5kV input power and controls
Surge	
IEC	IEC 61000-4-5, Level 3, 4kV line-to-line; level 4, 4kV line-to-ground
ANSI/IEEE	C62.41 Surge and Ring Wave Compliance to a level of 6kV line-to-line
Hi-Potential Test	
	Meets UL508 (2 x rated V + 1000V for 1 min.)
Safety Marks	
UL (OT08 octal socket required)	UL508 (File #E68520)
CE	IEC 60947-6-2
Enclosure	Polycarbonate
Dimensions	
	1.750" H x 2.375" W x 4.125" D (with socket) (44.45 x 60.325 x 104.775mm)
Weight	0.7 lb. (11.2 oz., 317.51 g)
Mounting Method	
	DIN rail or surface mount (plug into OT08 socket)



The Model ALT

alternating relays are used to alternate between two loads. The ALT is commonly used in duplex pumping applications to balance the runtime of both pumps.

The Model ALT-S

is used in single high-level float applications. When the float switch opens, the alternating relay changes state, forcing the other pump to run the next time the float closes.

The Model ALT-X

has an internal cross-connected relay and is used in dual high-level float applications. These floats are commonly referred to as lead and lag floats. The pumps alternate as in the ALT-S version but

the cross-connected relay configuration allows both pumps to run simultaneously when both the lead and lag floats are closed.

These relays are also available with a built-in switch (SW option) that is used to manually force one of the pumps to run every time the float switch is closed. This is helpful when a pump has been removed for repair or for test purposes. In the case of the Model ALT-X-SW, the switch essentially forces one pump to be the lead pump, while still allowing the second to run when both floats are closed. All Model ALT relays have a built-in debounce feature that prevents the relay from changing state if the switch or float contact bounces momentarily.

For more information see:

See Appendix A, page 68, Figure 8 for dimensional drawing.

See Appendix B, page 79, Figures 42 & 43 for typical wiring diagrams.

Must use Model OT08 socket for UL Rating!

Features:

- Alternate between two loads
- Debounce time delay
- Optional built-in manual/auto switch
- SPDT or cross-wire connected DPDT

Approvals:  

Auxiliary Products:

- 8-pin octal socket (P/N: CT0T08-PC)

Available Models:

ALT-24-S
 ALT-24-S-SW
 ALT-115-S
 ALT-115-S-SW
 ALT-115-X
 ALT-115-X-SW
 ALT-230-S
 ALT-230-S-SW
 ALT-230-X
 ALT-230-X-SW

Specifications

Input Characteristics

Supply Voltage	
24VAC	20-26VAC
115VAC	95-125VAC
230VAC	195-250VAC
Supply Current	40mA

Functional Characteristics

Debounce Time Delay	0.5 second
Control Input Impedance (min.)	

24	10kΩ
115	56kΩ
230	100kΩ

Output Characteristics

Output Contact Rating	480VA @ 240VAC
-----------------------	----------------

General Characteristics

Temperature Range	-40° to 50°C (-40° to 122°F)
Maximum Input Power	5 W

Safety Marks

UL (OT08 octal socket required)	UL508 (File #E68520)
---------------------------------	----------------------

CSA	C22.2 No. 14 (File #46510)
-----	----------------------------

Dimensions	1.750" H x 2.375" W x 4.125" D (with socket)
	(44.45 x 60.325 x 104.775mm)

Weight	0.38 lb. (6.08 oz., 172.67 g)
--------	-------------------------------

Mounting Method	DIN rail or surface mount (plug into OT08 socket)
-----------------	---

Socket Available	Model OT08 (UL Rating 600V)
------------------	-----------------------------

The 600V socket can be surface mounted or installed on DIN Rail.

Alternating Relay

Model ALT-xxx-1-SW / ALT-xxx-3-SW

11-pin plug-in for single float input with DPDT output / 8-pin plug-in for three float input with dual load output



The Model ALT-xxx-1-SW and ALT-xxx-3-SW

are used to alternate between two loads and are commonly used in duplex pump-up and pump-down applications to balance the runtime of both pumps.

The ALT-xxx-1-SW alternating relays are 11-pin octal base plug-ins, available in two different single-phase voltage ranges. The ALT-100-1-SW is used for 95-120VAC applications and the ALT-200-1-SW is used for 190-240VAC applications. Both models are designed for a single float input and feature two isolated Form C relays (DPDT) outputs with two LEDs to indicate the energized loads.

The ALT-xxx-3-SW alternating relays are 8-pin octal base plug-ins, available in two different single-phase voltage ranges. The ALT-100-3-SW is used for 95-120VAC applications and the ALT-200-3-SW is used for 190-240VAC applications. Both models are designed for three float inputs (lead, lag and stop floats). The lead and lag floats actuate latching relays that release when the stop float actuates. The units feature two LEDs to indicate the energized load(s).

The ALT relays have a built-in debounce time delay that prevents the relay from changing state if the float momentarily bounces, and they have a built-in switch to manually force a specific load (pump) to operate each time the input float closes. This is helpful when performing periodic maintenance or pump repair.

For more information see:



See Appendix A, page 68, Figure 8 for dimensional drawing.

See Appendix B, pages 79 & 80, Figures 44 & 45 for typical wiring diagrams.

Must use Model OT08 or OT11 socket for UL Rating!

Features:

- Debounce time delay
- LED load indicators
- Built-in switch to manually force a specific load (pump) to operate

Approvals:  

Auxiliary Products:

- 8-pin octal socket (P/N: CT0T08-PC)

Available Models:

ALT-100-1-SW
ALT-200-1-SW
ALT-100-3-SW
ALT-200-3-SW

Specifications

Input Characteristics

Supply Voltage

ALT-100-1-SW, ALT-100-3-SW95-120VAC

ALT-200-1-SW, ALT-200-3-SW190-240VAC

Frequency50/60Hz

Functional Characteristics

Debounce Time Delay

ALT-100-1-SW, ALT-200-1-SW1 second

ALT-100-3-SW, ALT-200-3-SW5 seconds

Output Characteristics

Output Relay (DPDT)

Pilot Duty480VA @ 240VAC

General Purpose10A @ 240VAC

General Characteristics

Temperature Range-40° to 70°C (-40° to 158°F)

Maximum Input Power5 W

Standards Passed

Electrostatic Discharge (ESD).....IEC 61000-4-2, Level 3, 6kV contact, 8kV air

Radio Frequency, Radiated150MHz, 10V/m

Fast Transient BurstIEC 61000-4-4, Level 3, 3.5kV
input power and controls

Safety Marks

UL (OT08 or OT11 octal socket required)UL508 (File #E68520)

CEIEC 60947-6-2

Dimensions1.750" H x 2.375" W x 4.125" D (with socket)
(44.45 x 60.325 x 104.775mm)

Weight0.65 lb. (10.4 oz., 294.84 g)

Mounting MethodDIN rail or surface mount (plug into
OT08 or OT11 socket)

Sockets Available

Model OT08UL Rating 600V

Model OT11UL Rating 300V

The sockets can be surface mounted or installed on DIN Rail.



The Model 50R-400-ALT

alternating relays are used to alternate between two loads, most commonly in duplex pumping and compressor applications to balance the runtime of both loads.

When used in single float applications, the alternating relay changes state after the float switch opens*, forcing the other pump to run the next time the float closes. When used in dual float applications, the alternating relay will allow both pumps to run simultaneously when the lead and lag floats are both closed.

An adjustment knob provides the option to force one pump to run every time the float switch is closed. This is helpful when one pump has been removed for repair or for test purposes.

A built-in debounce feature prevents the alternating relay from changing state if the float contact bounces momentarily.

For more information see:

See Appendix A, page 68, Figure 7 for dimensional drawing.

See Appendix B, page 80, Figure 46 for typical wiring diagrams.

* The alternating relay will not switch states while current is flowing. Switching will only occur after current has been sensed, followed by loss of current for the duration of the debounce time delay.

Features:

- Alternates between two loads
- Solid-state reliability
- Debounce time delay
- Compatible with single or dual float applications

Approvals:  

Available Models:

50R-400-ALT

Specifications

Input Characteristics	
Supply Voltage	380-480VAC
Supply Current	40mA
Functional Characteristics	
Control Input Impedance (min)	1MΩ
Output Characteristics	
Output Contact Rating	
Pilot Duty	.470VA @ 600VAC
General Purpose	10A
Debounce Time Delay	.1 second
General Characteristics	
Maximum Input Power	.5 W
Terminal	
Torque	.7 in.-lbs.
Wire Size	.12-18AWG
Safety Marks	
UL	UL508 (File #E68520)
CE	IEC 60947
Dimensions	2.93"H x 5.27"W x 2.95"D (74.4 x 133.9 x 74.9mm)
Weight	.098 lb. (15.68 oz., 444.52 g)
Mounting Method	#8 screws



The Model ACBC-120

is a dual purpose alarm controller/battery charging unit. When there is a loss of 120VAC power, the ACBC-120's primary function as an alarm controller activates. When this power loss occurs, input power is switched to a 12VDC, lead-acid, rechargeable backup battery and a 12VDC alarm consisting of a strobe light and/or a horn is activated. The horn follows a 2 second on/2 second off pattern with a "horn silence" option to turn the sound off. An LED indicator on the unit also signals that the device entered the alarm mode.

When 120VAC input is present the alarm circuit can be tested and the unit's secondary function as a 12VDC backup battery charger is activated. In fast charge mode, the unit has the capability to source up to 100mA of charging current. However, the

device normally charges at a current of 14mA in maintenance mode. The alarm circuit can be tested by pressing the "test" button located on the front of the unit or by activating an external switch via the "alarm contact" pin.

The device has the ability to signal low battery voltage if the voltage drops below 10.5VDC. The device can also detect if no battery is present or if the battery is connected backwards. In either of these cases, the ACBC-120 will signal a battery error and will not attempt to charge.

For more information see:

See Appendix A, page 68, Figure 8 for dimensional drawing.

See Appendix B, page 80, Figure 47 for typical wiring diagrams.

Must use Model SD12 socket for UL Rating!

Features:

- Controls 12VDC alarm circuit (strobe light and/or horn)
- Maintains 12VDC battery charge (fast charge mode and maintenance mode)
- Trip delay timer
- Battery fault detection and reverse polarity protection
- LED indicates unit's status
- Press-to-test capability

Approvals: 

Available Models:

ACBC-120

ACBC-120-SD (sold with SD12 socket)

Specifications

Input Characteristics

Supply Voltage	120V ±10%
AC Input Voltage	50/60Hz
Frequency	0.018A (max.) 0.003 (typical)
AC Input Current	2.4W (max.) fast charge current
AC Input Power	0.4W (typical) maint. charge current

Functional Characteristics

Battery Charging Characteristics

Acceptable Battery Type	12V lead-acid rechargeable
Fast Charge Current	100mA ±10%
Maintenance Charge Current	14mA ±50%
Low Battery Alert Level	10.5V

Output Characteristics

Strobe Light Alarm Output	12VDC@1A (max.)
Horn Alarm Output	12VDC@1A (max.)

General Characteristics

Temperature Range	-40° to 60°C (-40° to 140°F)
-------------------	------------------------------

Standards Passed

Electrostatic Discharge (ESD)	IEC 61000-4-2, Level 3, 6kV contact, 8kV air
Radio Frequency, Radiated	150MHz, 10V/m
Fast Transient Burst	IEC 61000-4-4, Level 4, 4kV input lines; 4kV signal lines

Safety Marks

UL (SD12 socket required)	UL508 (File #E68520)
Dimensions	1.750" H x 2.375" W x 4.125" D (with socket) (44.45 x 60.325 x 104.775mm)
Weight	0.7 lb. (11.2 oz., 317.51 g)
Mounting Method	Surface mount with #8 or #10 screws (plug into SD12 socket)

Sockets Available

Model SD12-PC	UL Rating 600V
---------------	----------------

Intrinsically Safe Relays/Controllers

An Intrinsically-Safe Switch is an isolated UL913 listed device used to interface between hazardous and non-hazardous areas. The input circuitry is designed to never supply excessive energy thus greatly reducing the likelihood of a spark. Provides intrinsically-safe circuits in the following locations: Division 1 and 2, Class I, Groups A, B, C, D; Class II, Groups E, F, G and Class III hazardous locations.

Product Selection Matrix

MODEL	UL 913	1 Channel	2 Channel	3 Channel	4 Channel	5 Channel	Selectable Inverted Logic	5 Amp General Purpose	7 Amp General Purpose	8 Amp General Purpose	DIN Rail Mountable	Surface Mountable	Octal Base	Output Status Lights	Probe Resistance 10k Ohms	Probe Resistance 100k Ohms
ISS-100	•	•									•	•	•	•		
ISS-101	•	•									•	•	•	•		
ISS-102AA-DCS	•		•				•				•	•	•	•		•
ISS-105-ISO	•					•	•				•	•	•	•		
ISS-105-ISO-3	•			•			•				•	•	•	•		
ISS-105-ISO-4	•				•		•				•	•	•	•		
ISS-105-ISO-F	•					•	•				•	•	•	•		

MODEL	2 Inputs	2 Outputs	Latching Logic	Selectable Inverted Logic	5 Amp General Purpose	DIN Rail Mountable	Surface Mountable	100K Ohm Fixed	4-7-100K Ohm Adjustable	Isolated Relay	MSHA Evaluated
ISS-102C-M-LC	•										•
ISS-102CCI-M-MC	•	•	•	•	•	•	•	•	•	•	•

MODEL	UL 913	2 Inputs	5 Inputs	2 Outputs	5 Outputs	Latching Logic	Selectable Inverted Logic	5 Amp General Purpose	7 Amp General Purpose	DIN Rail Mountable	Surface Mountable	100k Ohm Fixed	4-7-100k Ohm Adjustable	10k Ohm Fixed	Isolated Form C Relay	Form A Relay
ISS-102A-LC	•	•									•					
ISS-102ACI-MC	•	•		•							•					
ISS-105	•				•						•				•	•

* Denotes 4 relays

Intrinsically Safe Relay

Model ISS-100 / ISS-101 single-channel intrinsically safe switch, either din rail mount (100) or 8-pin socket mount (101)



The Model ISS-100 & ISS-101

switches are UL 913 listed as an associated apparatus for interfacing between hazardous and non-hazardous areas. These units must be installed in a non-hazardous area.

For more information on the ISS-100 see: See Appendix A, page 69, Figure 11 for dimensional drawing.

For more information on the ISS-101 see: See Appendix A, page 68, Figure 8 for dimensional drawing.

Features:

ISS-100

- Compact design
- Finger-safe terminals
- DIN rail or surface mountable
- LED state indicator
- Isolated output relay for PLC or control voltage

ISS-101

- Compact design
- LED state indicator
- DIN rail or surface mountable via common octal-base package
- Pop-in replacement for other manufacturers' parts
- Isolated output relay for PLC or control voltage

Approvals:

Auxiliary Products:

- 8-pin octal socket (P/N: CT0T08-PC)

Available Models:

- ISS-100
- ISS-101

Must use Model OT08 socket for UL Rating!

Specifications

Input Characteristics	
Supply Voltage	90-120VAC
Output Characteristics	
Output Contact Rating	
Pilot Duty	180VA @120VAC, C300
General Purpose8A @120VAC
Relay Contact Life (Electrical)	100,000 cycles min. @ rated load
Relay Contact Life (Mechanical)	10,000,000 cycles
General Characteristics	
Temperature Range	-20° to 55°C (-4° to 131°F)
Maximum Input Power	1.5 W
Wire range12 to 20 AWG
Terminal Torque	3.5 to 4.5 in.-lbs. (max. 6 in.-lbs.)
Provides intrinsically-safe circuits in the following locations:	Division 1 and 2 Class I, Groups A,B,C,D; Class II, Groups E,F,G; and Class III
Entity Parameters	$V_{oc} = 16.8V$ $P_o = \frac{V_{oc}^2 I_{sc}}{4}$ $I_{sc} = 1.2mA$ $L_p = 100mH$ $C_a = 0.39uF$

Standards Passed	
Electrostatic Discharge (ESD)	IEC 61000-4-2, Level 3, 6kV contact, 8kV air
Radio Frequency Immunity (RFI)	IEC 61000-4-3, Level 3, 10V/m
Fast Transients	IEC 61000-4-4, Level 3, 4kV input power
Safety Mark	
UL (OT08 octal socket required)	UL913 Sixth Edition (File #E233355)
Dimensions	
ISS-100	3.5" H x 2.084" W x 2.350" D (88.9 x 52.93 x 59.69mm)
ISS-101	1.750" H x 2.375" W x 4.125" D (with socket) (44.45 x 60.325 x 104.775mm)
Weight	
ISS-100	0.5 lb. (8 oz., 226.8 g)
ISS-101	0.5 lb. (8 oz., 226.8 g)
Mounting Method	
ISS-100	35mm DIN rail or Surface Mount (#6 or #8 screws)
ISS-101	DIN rail or surface mount (plug into OT08 socket)

Intrinsically Safe Relay

Model ISS-102

two-channel intrinsically safe switch, din rail mount, options include switch only (-DCS), single latching output (-LC), or multi-function controller (-MC)



The ISS-102

SymCom's Model ISS-102 two-channel, intrinsically-safe switch is designed for multiple uses including a pump-up/pump-down (latching) controller or two-channel switch. Two LEDs indicate the state of the intrinsically-safe inputs and output relays and user-selectable options are available including a variable resistance threshold for float inputs. The ISS-102 enclosure is surface or DIN rail mountable.

-LC Each input channel is active when the corresponding switch is closed. When the lag input (CH2) is activated, the output closes. Applying latching logic, the output contact remains closed until the lead (CH1) and the lag (CH2) inputs are deactivated. Sensitivity is fixed at 100kOhms with a debounce time delay of 2 seconds.

-DCS This dual-channel switch has a debounce delay feature of 0.5 seconds. Resistance probes or switches can be used on its inputs. Two LEDs illuminate the output state of either form A relay. Sensitivity is fixed at 100kOhms with a debounce time delay of 0.5 seconds.

-MC By selecting the proper functionality through the dip switches, you can define a pump-up or pump-down, single or dual channel non-latching switch. The sensitivity adjustment (4.7k-100kOhms) allows you to define the input impedance at which the output relays (one form A & one form C) will change state, with a debounce time delay of 0.5 or 2 seconds.

For more information see:

See Appendix A, page 69, Figure 11 for dimensional drawing.

Features:

- Compact design
- Finger-safe terminals
- DIN rail or surface mountable
- LED state indicator
- 2 input channels

Approvals: 

Available Models:

ISS-102A-LC (Latching Controller)
 ISS-102AA-DCS (Dual Channel Switch)
 ISS-102ACI-MC (Multi-function Controller)
 ISS-102C-M-LC (MSHA* evaluated)
 ISS-102CCI-M-MC (MSHA* evaluated)

* Mine Safety and Health Administration

Specifications

Input Characteristics	
Supply Voltage	120VAC
Functional Characteristics	
Debounce Time	.05 or 2 seconds
Output Characteristics	
Output Contact Rating	
Pilot Duty	.180VA @120VAC, C150
General Purpose	.5A @120VAC
Relay Contact Life (Electrical)	100,000 cycles min. @ rated load
Relay Contact Life (Mechanical)	10,000,000 cycles
Output Relay Type:	
ISS-102A-LC	One Form A
ISS-102AA-DCS	Two Form A
ISS-102ACI-MC	One Form A & One isolated Form C
ISS-102C-M-LC	One Form C
ISS-102CCI-M-MC	Two Form C (one isolated)
General Characteristics	
Temperature Range	-20° to 55°C (-4° to 131°F)
Maximum Input Power	.2 W
Wire range	.12 to 20 AWG
Terminal Torque	.35 to 4.5 in.-lbs. (max. 6 in.-lbs.)

Provides intrinsically-safe circuits in the following locations:	Division 1 and 2 Class I, Groups A,B,C,D; Class II, Groups E,F,G; and Class III
Entity Parameters	$V_{oc} = 16.8V$ $P_o = \frac{V_{oc} \cdot I_{sc}}{4}$ $I_{sc} = 1.2mA$ $L_s = 100mH$ $C_s = 0.39uF$
Standards Passed	
Electrostatic Discharge (ESD)	.IEC 61000-4-2, Level 3, 6kV contact, 8kV air.
Radio Frequency Immunity (RFI)	.IEC 61000-4-3, Level 3, 10V/m
Fast Transients	.IEC 61000-4-4, Level 3, 4kV input power
Safety Mark	.UL913 Sixth Edition (File #E233355) (except Models ISS-102C-M-LC & ISS-102CCI-M-MC which have been evaluated by MSHA)
Dimensions	.35" H x 2.084" W x 2.350" D (88.9 x 52.93 x 59.69mm)
Weight	.07 lb. (11.2 oz., 317.51 g)
Mounting Method	.35mm DIN rail or Surface Mount (#6 or #8 screws)

Intrinsically Safe Relay

five-channel intrinsically safe switch, din rail mount, programmable for alternating/control of 2, 3 or 4 pumps or 5-channel relay, optional 5-channel switch only (-ISO)

Model ISS-105

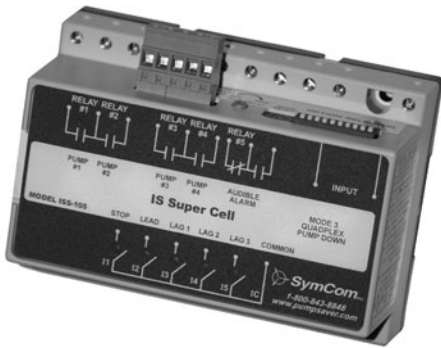

The ISS-105 IS Super Cell

is a "smart" five-channel intrinsically safe relay and pump controller. The IS Super Cell can be configured for a wide variety of applications including alternating or non-alternating duplex, duplex separate pump stop (SPS), triplex and quadplex applications. It can be set up for pump-up or pump-down applications or can be used as a five-channel relay.

The IS Super Cell has a long list of features that are needed for multiple pump applications. The IS Super Cell can indicate low, high and out-of-sequence alarms. If an out-of-sequence alarm occurs, the skipped pump(s) will be started as intended. The Model ISS-105 can be set up to do non-alternating control, alternating control and alternating control with one non-alternating pump. The non-alternating pump is intended for use with an emergency or jockey pump. The IS Super Cell can start an emergency pump once every 50 cycles to keep it working freely. Using the built-in DIP switches, individual pumps can be disabled when taken out of service for repair or maintenance.

For more information see:
See Appendix A, page 70, Figure 13 for dimensional drawing.

Features:

- 5 intrinsically-safe input channels meeting UL913 Sixth Edition
- 4 normally open output relays and 1 SPDT output relay
- Field selectable pump control options
- Duplex pump control
- Duplex SPS (separate pump stop) pump control
- Triplex pump control
- Quadplex pump control
- Out-of-sequence alarm
- High and/or low alarm options depending on the number of pumps and settings
- Audible alarm output
- Meets IEC EMC standards for Electrical Fast Transients (EFT), Electrostatic Discharge (ESD) and Radio Frequency Immunity (RFI)
- DIN rail or surface mountable
- User-selectable alternator/non-alternator option
- Non-alternating pump option for emergency or jockey applications
- Pump disable switches
- Adjustable lag pump delay for all pumping modes
- Adjustable delay-on-make/break timer in five-channel relay mode
- Finger-safe terminals

Approvals:

Available Models:

- ISS-105 (Intrinsically-Safe & Pump Controller)
- ISS-105-ISO (Intrinsically-Safe Only)
- ISS-105-ISO-3 (3-Channel Intrinsically-Safe Only)
- ISS-105-ISO-4 (4-Channel Intrinsically-Safe Only)
- ISS-105-ISO-F (IS Only with Fast Trip Relays)

Specifications

Input Characteristics	
Supply Voltage	120VAC
Frequency	50*/60Hz
Output Characteristics	
Relay Output Rating	
Pilot Duty	480VA @ 240VAC, B300
General Purpose	7A @ 240VAC
Relay Contact Life (Electrical)	100,000 cycles min. @ rated load
Relay Contact Life (Mechanical)	10,000,000 cycles
General Characteristics	
Temperature Range	-40° to 55°C (-40° to 131°F)
Maximum Input Power	.5 W
Wire range	12 to 20 AWG
Recommended Terminal Torque	.35 to 4.5 in.-lbs. (max. 6 in.-lbs.)
Provides intrinsically-safe circuits in the following locations:	Division 1 and 2 Class I, Groups A,B,C,D; Class II, Groups E,F,G; and Class III
Entity Parameters	$V_{oc} = 16.8V$ $P_o = \frac{V_{oc} \cdot I_{sc}}{4}$ $I_{sc} = 1.2mA$ $L_p = 100mH$ $C_a = 0.39uF$

Standards Passed	
Electrostatic Discharge (ESD)	IEC 61000-4-2, Level 3, 6kV contact, 8kV air.
Radio Frequency Immunity (RFI)	IEC 61000-4-3, Level 3, 10V/m
Fast Transients	IEC 61000-4-4, Level 3, 4kV input power 2kV inputs/outputs
Safety Marks	
UL	UL913 Sixth Edition (File #E233355)
Dimensions	3.703" W x 5.025" L x 2.35" H (94.06 x 127.64 x 59.69mm)
Weight	1.2 lbs. (19.2 oz., 544.31 g)
Mounting Method	35 mm DIN rail or Surface Mount (#6 or #8 screws)

*Note: 50Hz will increase all delay timers by 20%.

Single-Phase PumpSavers

Our line of single-phase PumpSavers provide ideal protection from dry-well and dead-head situations, as well as overload, over and undervoltages and rapid cycling. The 77C-KW/HP family of power monitors provide this same protection and much more with programmable parameters, diagnostic display of fault codes to aid in troubleshooting and remote communication capability.

SEE OUR SINGLE-PHASE PUMPSAVER CATALOG FOR OUR
FULL LINE OF SINGLE-PHASE PUMPSAVERS
(AVAILABILITY SUBJECT TO CHANGE).

TABLE OF CONTENTS

Submersible Pumps - Optimized Protection	
Whose Control Box do you have?	
Franklin™, CentriPro™ or Pentek®	2
115VAC	
1/3-1/2hp... 111-Insider-P	
230VAC	
1/3-1hp... 231-Insider-P	
Grundfos®	4
230VAC	
1/3-1hp... 232-Insider	
1/3-3hp... 234-P	
Don't need a control box?	8
115VAC	
1/3-1hp... 111P	
230VAC	
1/3-1.5hp... 233P-1.5	
1/3-3hp... 233P	
5-15hp... 235P	
Want a PumpSaverPlus in its own NEMA box?	12
115VAC	
1/3-1hp... 111P-ENCL	
230VAC	
1/3-1.5hp... 233P-1.5-ENCL	
1/3-3hp... 233P-ENCL	
5-15hp... 235P-ENCL	
Hand-held Diagnostic Tool - Informer	16
Any Other Pump:.....	18
Single-Phase Programmable pump protection... 77C-KW/HP (2-800 Amps)	
Single-Phase Low-range prog. pump protection... 77C-LR-KW/HP (1-9 Amps)	
Three-Phase Programmable overload relay... 777-P2	
Three-Phase Low-range prog. overload relay... 777-LR-P2	
Three-Phase High Control Voltage prog. overload relay... 777-HVR-P2	
Three-Phase Programmable power monitor... 777-KW/HP-P2	
Three-Phase Low-range prog. power monitor... 777-LR-KW/HP-P2	
Three-Phase Medium-Low range prog. power monitor... 777-MLR-KW/HP-P2	
Three-Phase High Control Voltage prog. power monitor... 777-HVR-KW/HP-P2	
Ancillary Products:	
Do you need to know the liquid level in any tank?	24
Liquid Level Sensor Relay (DIN Rail or surface mount)... 460-15-100-LLS	
Liquid Level Control Relay (8-pin plug in)... PC-xxx-LLC-CZ	
Liquid Level Control Relay (8-pin plug in)... PC-xxx-LLC-GM	
Typical Wiring Diagrams.....	28
Installation Instructions	32
Product Dimensions	54
Other SymCom Products	57

Load Sensors

SymCom's load sensors are designed to be adaptable to many different applications. They utilize a CT (current transformer) inside the unit to read the current of the equipment being monitored. The Model LSR-0 is a self-powered unit used as a proof relay. The LSRX and LSRX-C units are also self-powered proof relays with either 0.25" fast-on connectors (LSRX) or depluggable connectors (LSRX-C) for use in OEM equipment. The LSR-24, 115 and 230 load sensors require external power and are ideally used to help determine feed rates, tool wear, loss of prime on pumps, mixer viscosity and all types of overload and underload conditions. LSRU load sensors come in many different configurations, such as overcurrent and undercurrent or either overcurrent or undercurrent with variable trip, restart or extended restart delay settings. All LSRU models require 115VAC external power source, except for the LSRU-24-AL-2 and LSRU-24-AL-3, which require 24VAC.

Product Selection Matrix

MODEL	Adjustable Overcurrent	Fixed Undercurrent (Proof Relay)	Adjustable Undercurrent	Manual Reset Selection	Variable Trip Point	Variable Restart Delay	Extended Restart Delay	Variable Trip Delay	10 Amp Relay	Self-Powered	Alarm Logic (Latching)	Motor Control Logic (Momentary Trip)
LSR-0		•							•	•		
LSR-24	•		•		•				•	•	•	
LSR-115	•		•		•				•	•	•	
LSR-230	•		•		•				•	•	•	
LSRU-24-AL-2	•		•		•				•	•	•	
LSRU-24-AL-3	•		•		•				•	•	•	
LSRU-115-AL-1.5	•		•		•				•	•	•	
LSRU-115-AL-2	•		•		•				•	•	•	
LSRU-115-AL-3	•		•		•				•	•	•	
LSRU-115-FC-1.5	•		•		•				•	•	•	
LSRU-115-OT-1.5	•				•			•	•	•		•
LSRU-115-OT-2	•				•			•	•	•		•
LSRU-115-OT-3	•				•			•	•	•		•
LSRU-115-OR-1.5	•			•	•	•		•	•	•		
LSRU-115-OR-2	•			•	•	•		•	•	•		
LSRU-115-UE-2			•	•	•	•	•	•	•	•		•
LSRU-115-UT-2			•	•	•	•	•	•	•	•		•
LSRU-115-UT-3			•	•	•	•	•	•	•	•		•
LSRU-115-UR-2			•	•	•	•	•	•	•	•		•
LSRU-115-UR-3			•	•	•	•	•	•	•	•		•
LSRU-115-OU-1.5	•		•		•			•	•	•		•
LSRU-115-OU-2	•		•		•			•	•	•		•
LSRU-115-OU-3	•		•		•			•	•	•		•
LSRX		•							•	•		
LSRX-C		•							•	•		



The Model LSR-0

is a self-powered load sensor intended for use as a proof relay. It is used to verify that current is flowing as intended. It has a guaranteed 15A pull-in current and 2.5A drop-out current. Proof relays are typically used to interlock fans, compressors, motors, heating elements and other devices. The LSR-0 is self-powered, that is, it draws its power from the wire being monitored so it does not require separate control power wiring.

For more information see:

See Appendix A, page 70, Figure 14 for dimensional drawing.

See Appendix B, page 81, Figure 50 for typical wiring diagrams.

Features:

- Self-powered
- Low cost proof relay
- Can monitor up to 135A loads

Approvals: 

Available Models:

LSR-0

Specifications

Max Current Ratings	135A continuous
Functional Characteristics	
Turn-on Threshold	Fixed, 15A (max.)*
Turn-off Threshold	2.5A (min.)
Power	Induced from conductor
Isolation	600VAC rms
Output Characteristics	
Relay Output Rating	
Pilot Duty	480VA @ 240VAC
General Purpose	10A
General Characteristics	
Temperature Range	-20° to 70°C (-4° to 158°F)
Wire Size	#12-24AWG
Hole Size	0.725" diameter
Terminal Torque	7 in.-lbs.
Safety Marks	
CSA, CSA-NRTL/C	(File #46510)
CE	
Dimensions	1.67" H x 2.3" W x 3.56" D (42.42 x 58.42 x 90.43 mm)
Weight	0.35 lb. (5.6 oz., 158.76 g)
Mounting Method	Four #6 screws 3/4" in length

*Conductors may be looped for smaller motor applications.

Caution: This product should not be relied upon solely for safety of life or safety applications.



The Model LSR-XXX

load sensors use current levels to determine feed rates, tool wear, loss of prime on pumps, mixer viscosity and all types of overload and underload conditions. They may also be used to stage pump motors, chillers and other machinery. These devices combine a current transformer (CT) with Form C (SPDT) relay contacts to switch alarm circuits, contactors or any resistive or inductive load. One simple screwdriver adjustment will calibrate the sensor for all single-phase or 3-phase applications up to 100hp.



For more information see:

See Appendix A, page 70, Figure 14 for dimensional drawing.

See Appendix B, page 80, Figure 48 for typical wiring diagrams.

Features:

- Can monitor current of motors up to 100Hp
- Fine adjustment with 20-turn pot
- Status LEDs

Approvals:  

Available Models:

LSR-24
LSR-115
LSR-230

Specifications

Functional Characteristics

Isolation	600VAC rms
Current Adjustment Range (Typical)	2-100A
Current Adjustment Range (Min-Max)	0.5-135A
Trip Setpoint	Adjustable to $\pm 1\%$ range

Input Characteristics

Control Power	
LSR-24	24VAC
LSR-115	115VAC
LSR-230	230VAC
Max Current Ratings	135A max. continuous

Output Characteristics

Output Contact Rating (SPDT)	
Pilot Duty	480VA @ 240VAC
General Purpose	10A

General Characteristics

Temperature Range	-20° to 70°C (-4° to 158°F)
Wire Size	#12-24AWG
Hole Size	0.725" diameter
Terminal Torque	7 in.-lbs.

Safety Marks

CSA, CSA-NRTL/C	(File #46510)
CE	IEC 60947
Dimensions	1.67" H x 2.3" W x 3.56" D (42.42 x 58.42 x 90.43 mm)

Weight	0.4 lb. (6.4 oz., 181.44 g)
Mounting Method	Four #6 screws 3/4" in length

Caution: This product should not be relied upon solely for safety of life or safety applications.



The Model LSRU

is a microcontroller-based family of load sensors. The LSRU family of products employ three basic types of control logic: motor control logic, alarm logic and feed control logic.

Motor Control Logic

Several combinations of functions are available in the LSRU, including overcurrent and undercurrent or either overcurrent or undercurrent with variable trip, restart or extended restart delay settings. These various versions of the LSRU trip on the respective fault and then automatically reset after the restart delay expires, in preparation for the next motor start. LSRUs do not trip on undercurrent when the load turns off, this is recognized as a normal condition.

Alarm Logic

The LSRU-AL simply indicates whether the current is between the setpoints or outside of the setpoints. This product is best used with a PLC or other controller where status indication is desired.

Feed Control

The LSRU-FC is a load monitor intended to control feeder mechanisms in a variety of applications. It stops the feeder when the grinder, chipper, saw, auger, etc. nears overload. When the load is reduced to a preset level, the feeder is restarted.

For more information see:

See Appendix A, page 70, Figure 14 for dimensional drawing.

See Appendix B, page 80, Figure 49 for typical wiring diagrams.

Features:

- Alarm logic available in 24VAC or 115VAC
- Choice of multiple functions for motor control logic
- Motor control logic functions available in multiple current ranges
- Status LED

Approvals:  

Available Models:

- LSRU-24-AL-2
- LSRU-24-AL-3
- LSRU-115-AL-1.5
- LSRU-115-AL-2
- LSRU-115-AL-3
- LSRU-115-FC-1.5
- LSRU-115-OT-1.5
- LSRU-115-OT-2
- LSRU-115-OT-3
- LSRU-115-OR-1.5
- LSRU-115-OR-2
- LSRU-115-UE-2
- LSRU-115-UT-2
- LSRU-115-UT-3
- LSRU-115-UR-2
- LSRU-115-UR-3
- LSRU-115-OU-1.5
- LSRU-115-OU-2
- LSRU-115-OU-3

Specifications

Functional Characteristics

Isolation	600VAC rms
Power	2 Watts
Motor Acceleration Time	2 seconds
When not selected as an option:	
Fixed Trip Delay	0.5 second
(-AL, -FC)	1 second
Fixed Restart Delay	1 second
(-AL only)	as soon as current is within limits
(-FC only)	0.5 second
Input Characteristics	
Control Power	24VAC or 115VAC
Output Characteristics	
Output Contact Rating (SPDT)	
Pilot Duty	480VA @ 240VAC
General Purpose	10A

General Characteristics

Temperature Range	-40° to 70°C (-40° to 158°F)
Wire Size	#12-24AWG
Hole Size	0.725" diameter
Terminal Torque	0.7 in.-lbs.
Safety Marks	
CSA, CSA-NRTL/C	(File #46510)
CE	
Dimensions	1.67" H x 2.3" W x 3.56" D (42.42 x 58.42 x 90.43 mm)
Weight	0.5 lb. (8 oz., 226.8 g)
Mounting Method	Four #6 screws 3/4" in length

Caution: This product should not be relied upon solely for safety of life or safety applications.

- O - Overcurrent Trip
- U - Undercurrent Trip
- T - Adj. Trip Delay (0.5-60 seconds)
- R - Adj. Restart Delay (0.5-300 seconds, Manual)
- E - Adj. Extended Restart Delay (2-300 minutes, Manual)

- 1.5 - 0-10 Amps
- 2 - 5-25 Amps
- 3 - 25-100 Amps



The Model LSRX



is an AC current sensor designed to energize the output contact whenever 4.5 Amps or greater is present. The LSRX is used commonly as an AC current proof relay to indicate if a motor is operating. It can also be used to interlock fans, compressors and motors; to indicate equipment status such as feed rates, tool wear, loss of prime on pumps, mixer viscosity and all types of current sensing conditions or to stage pump motors, chillers, or other machinery.

This device combines a current transformer (CT), transducer and high current output relay together to switch alarm circuits, contactors and most resistive or inductive loads. The LSRX can perform the function of an auxiliary contact, yet has the advantages of universal application and isolation.

For more information see:
See Appendix A, page 70, Figure 15 for dimensional drawing.

Features:

- Self-powered
- Low cost proof relay
- Can monitor up to 200A loads
- Fast-on terminals or optional depluggable screw terminals (LSRX-C)
- LED status indicator
- Optional header for remote fiber optic panel indicator

Approvals:  

Available Models:

- LSRX
- LSRX-C
- LSRX-OEM (10 pack)
- LSRX-C-OEM (10 pack)

Specifications

Input Characteristics	
Operating Current	.5-200A Continuous
Minimum Pull-in Current	.45A (typical), 7.0A (max)*
Power	Induced from AC conductor
Output Characteristics	
Relay Output Rating (SPST - Form A)	
Pilot Duty	.480VA @ 240VAC, B300
General Purpose	.5A @ 240VAC
Electrical Life	.1x10 ⁵
Mechanical Life	.1x10 ⁷
Maximum Conductor Diameter	.07 in.
Output Terminals	
LSRX	.025" quick-connect fast-ons
LSRX-C	depluggable screw terminals
Torque Rating	.45 in.-lbs.
General Characteristics	
Temperature Range	
Operating	-20° to 70°C (-4° to 158°F)
Storage	-40° to 80°C (-40° to 176°F)
Hole Size	.072" diameter
Wire Size	.12-26 AWG

Output Relay Status Indicator	LED
Relative Humidity	10-95%, non-condensing per IEC 68-2-3
Standards Passed	
Electrostatic Discharge (ESD)	IEC 61000-4-2, Level 2, 4kV contact, 4kV air
Fast Transient Burst	IEC 61000-4-4, Level 3, 2kV power, 1kV input/output
Surge	
IEC	.61000-4-5, Level 3, 2kV line-to-line; 2kV line-to-ground
Safety Marks	
UL	UL508 Recognized (File #E68520)
CE	IEC 60947
Dimensions	2.7" H x 1.13" W x 2.5" D (68.58 x 28.7 x 63.5mm)
Weight	.03 lb. (4.8 oz., 136.08 g)
Mounting Method	Surface Mount

*Conductors may be looped for smaller motor applications.

Auxiliary Products

Products included:

- T-10 Timers
- CP-5 Single-phase Current Monitors
- Current Transformers (donut style & foot mounted)
- NEMA-3R Enclosures
- Steel Enclosure for RM-1000
- Electronic Megohmmeter
- Informer Infrared Kit
- OL-RESET
- Manual Remote Reset Kit
- Octal Sockets



Auxiliary Products



The Model T-10-(xxx)

on-delay timer is a solid-state electronic device that provides accurate and reliable timing for control circuits up to 460VAC. The T-10 features a user-selectable time delay from 6 seconds to 10 minutes (0.5 to 12 seconds on the T10S-400 model) and SPDT output contacts. When power is applied to the T-10, it immediately begins its timing cycle. During this time, the indicator LED alternates between red and green and the output contacts remain inactive. When the timing cycle is complete, the indicator LED turns solid green and the output contacts are activated. The output contacts will remain activated until power is removed from the T-10.

The SPDT contact ratings are 480V @ 240VAC on the 115V and 230V models and 470VA @ 600VAC on the 460V model.

For more information see:

See Appendix A, page 68, Figure 7 for dimensional drawing.

See Appendix B, page 81, Figure 51 for typical wiring diagrams.

Features:

- Status LED
- 600V control relay on 460V models

Approvals: 

Available Models:

- T10-100 (115V)
- T10-200 (230V)
- T10-400 (460V)
- T10S-400 (460V)

Specifications

Input Characteristics

Line voltage	
T10-100	115VAC
T10-200	230VAC
T10-400, T10S-400	460VAC
Frequency	50*/60Hz

Functional Characteristics

Timing Range	
T10-100, T10-200, T10-400	6 seconds to 10 minutes
T10S-400	0.5 seconds to 12 seconds

Repeat Accuracy

Fixed Condition	±1%
-----------------	-----

Output Characteristics

Output Contact Rating (SPDT)

Pilot Duty	
T10-100, T10-200	480VA @ 240VAC
T10-400, T10S-400	470VA @ 600VAC

General Characteristics

Maximum Input Power	5 W
Terminal	
Torque	7 in.-lbs.
Wire Size	12-18AWG
Safety Marks	
UL	UL508 (File #E68520)
Dimensions	2.93"H x 5.27"W x 2.95"D (74.4 x 133.9 x 74.9mm)
Weight	0.94 lb. (15.04 oz., 426.38 g)
Mounting Method	#8 screws

*Note: 50Hz will increase all delay timers by 20%.



The Model CP-5

is an undercurrent monitor designed to monitor one leg of a 3-phase system. It is commonly used as a tower monitor on center pivot irrigation systems to detect stalled or jammed towers to prevent overwatering.

The CP-5 has both an adjustable trip level and an adjustable trip delay timer. When the current is sensed, the Model CP-5 activates its output relay, thus starting the motor/pump. When the current in the monitored power line falls below the user-selectable trip point, the unit goes through a trip delay timer and then deactivates the output relay if the monitored current does not recover first.

For more information see:

See Appendix A, page 68, Figure 7 for dimensional drawing.

See Appendix B, page 81, Figure 52 for typical wiring diagrams.

Features:

- Ideal as a tower monitor on center pivot irrigation systems
- Adjustable trip level
- Adjustable trip delay

Approvals: 

Available Models:

CP-5-115
CP-5-460

Specifications

Input Characteristics

Nominal Input Voltage	
CP-5-115	.115VAC
CP-5-460	.460VAC
Frequency	.50*/60Hz

Functional Characteristics

Operating Points

Trip Level	.0-5 Amps
Trip Delay	.0-10 minutes
Restart	.1 second

Output Characteristics

Output Contact Rating (SPDT)

Pilot Duty	
CP-5-115	.480VA @ 240VAC
CP5-460	.470VA @ 600VAC

General Characteristics

Terminal

Torque	.7 in.-lbs.
Wire Size	.12-18AWG

Safety Marks

UL	.UL508 (File #E68520)
Dimensions	.2.93"H x 5.27"W x 2.95"D (74.4 x 133.9 x 74.9mm)
Weight	.1 lb. (16 oz., 453.59 g)
Mounting Method	.#8 screws

*Note: 50Hz will increase all delay timers by 20%

Current Transformers

instrumentation and metering transformers, choice of donut or foot mounted and 1 - 3" diameter opening



Current Transformers

SymCom offers a wide array of instrument rated current transformers.

Voltage class: 600V

BIL rating: 10kV

Available Models:

- CT-0050-D-10
- CT-0075-D-10
- CT-0100-D-10
- CT-0150-D-10
- CT-0200-D-10
- CT-0300-D-10
- CT-0200-D-20
- CT-0300-D-20
- CT-0400-D-20
- CT-0500-D-20

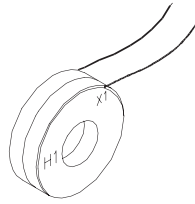

2RL

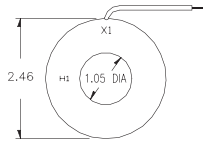
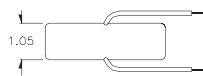

56RL

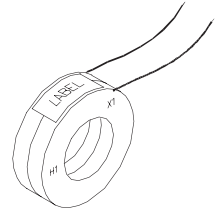
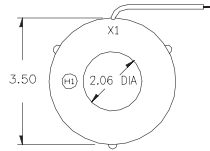
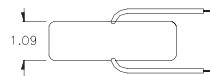

76RL

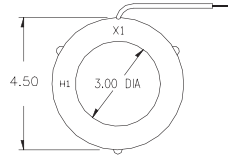
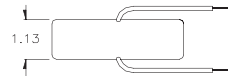

PART NUMBERS:

CT-xxx (xxx:5 current ratio)

-D/F (D=Donut Style, F=Footed Style)

-10/15/20/30 (10=1.0" window; 15=1.5" window; 20=2.0" window; 30=3.0" window)



BRASS TERMINALS WITH MOUNTING FEET

Available Models:

- CT-0050-F-10
- CT-0100-F-10
- CT-0150-F-10
- CT-0200-F-10
- CT-0300-F-10
- CT-1200-F15
- CT-0150-F-20
- CT-0200-F-20
- CT-0300-F-20
- CT-0400-F-20
- CT-0600-F-20
- CT-0400-F-30
- CT-0800-F-30

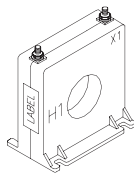

2SFT

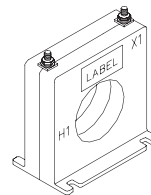
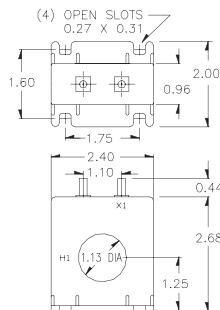

56SFT

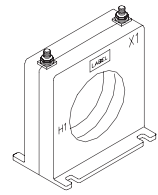
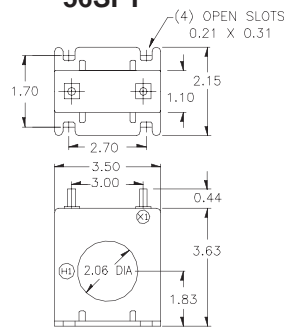

76SFT

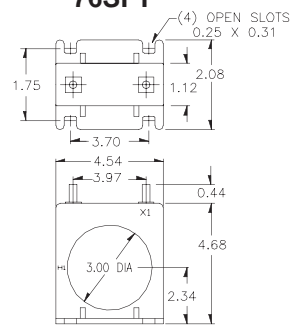

Auxiliary Products

enhanced ground fault protection, enclosures, diagnostic tool, enhancements/accessories for multiple SymCom products



Enclosure

Metal NEMA-3R electrical box (6" H x 6" W x 4" D) with lenses for viewing the single-phase PumpSaver® status lights

Part Number: NEMA-3R-L

The RM-1000-ENCL

is a steel enclosure for protecting a SymCom RM-1000 remote communications monitor from adverse affects of weather and vandalism, while allowing normal communications connections to the RM-1000 unit. Its superior design protects an RM-1000 from overexposure to UV sunlight as well as from hail during a storm, and it incorporates a seal around the opening in the back to seal the unit to the electrical box, keeping rain from contacting the RM-1000 connections. The enclosure also features a built-in padlock tab (padlock not included) to lock the cover to deter vandalism. (6.4" H x 6.3" W x 1.7" D)

Part Number: RM-1000-ENCL



Electronic Megohmmeter

The Model M-500 is an automatic, portable, battery-powered insulation tester. This unit is specifically designed as an inexpensive alternative to costly swing needle megohmmeters. The M-500 measures insulation resistance values of motors, generators and transformers up to 1000 megohms at 500VAC, indicating the condition of insulation on the zone scale. Its compact design and ease of use makes the M-500 a great diagnostic tool for motor rewind shops, electrical maintenance personnel and pump installers.

Part Number: M-500

Informer IR Kit

can be used with the MotorSaver® Model 455 and PumpSaver® Models 111-Insider-P and 231-Insider-P. It simply attaches to the face of the unit to provide remote diagnostics without opening the panel.

Part Number: IR Kit-36 (36" long)



The OL-RESET

allows the 777 line of MotorSaver® and PumpSaver® products to be manually reset without opening the panel door. Simply connect the module to the 777 communication port, connect a wire to each of the two applicable pins on the OL-RESET and to a normally-open push-button switch (sold separately). Mount the push-button switch in a convenient location.

Part Number: OL-RESET

777 Manual Remote Reset Kit (24" long)

allows the 777 line of MotorSaver® and PumpSaver® products to be manually reset without opening the panel door. Simply connect the 9-pin adapter to the 777 communication port and mount the push-button switch in a convenient location.

Part Number: 777-MRSW



OT08-PC



RB08-PC

Octal Sockets

for plug-in units.

Part Numbers: OT08-PC (8-pin surface & DIN rail mountable)
RB08-PC (8-pin surface mountable)
OT11-PC (11-pin surface & DIN rail mountable)
SD12-PC (12-pin surface mountable)

Appendix A - Dimensional Drawings

Figure 1 (777, 77C, 601)

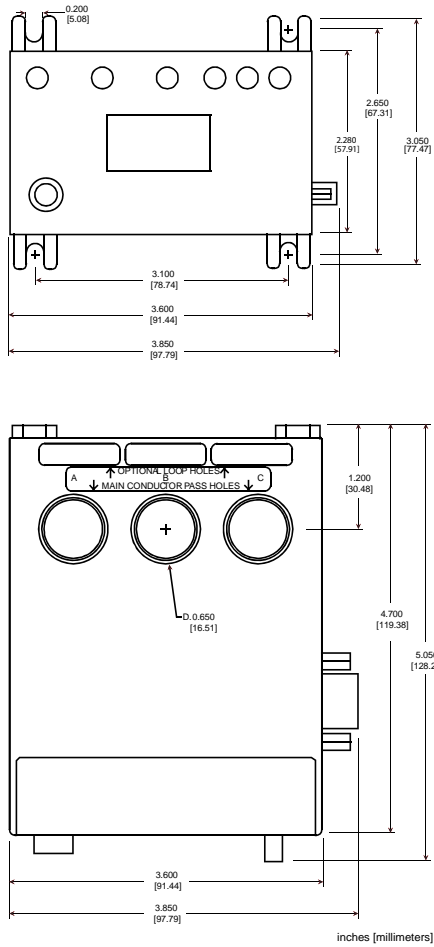

Figure 2 (COM modules)

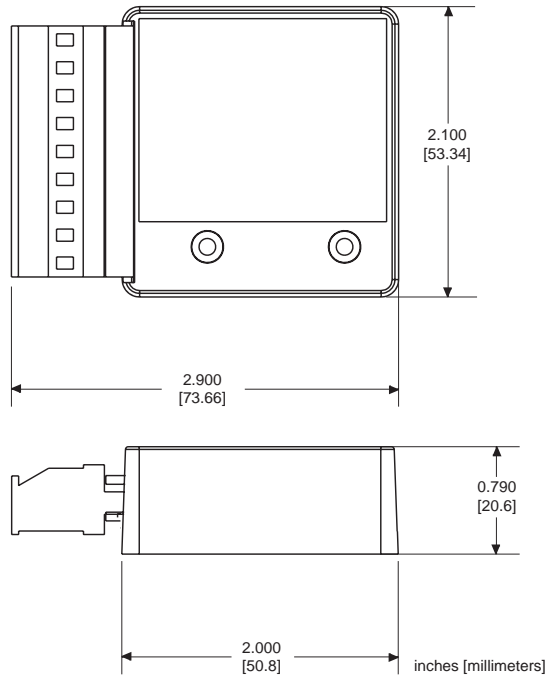

Figure 3 (CIO modules)

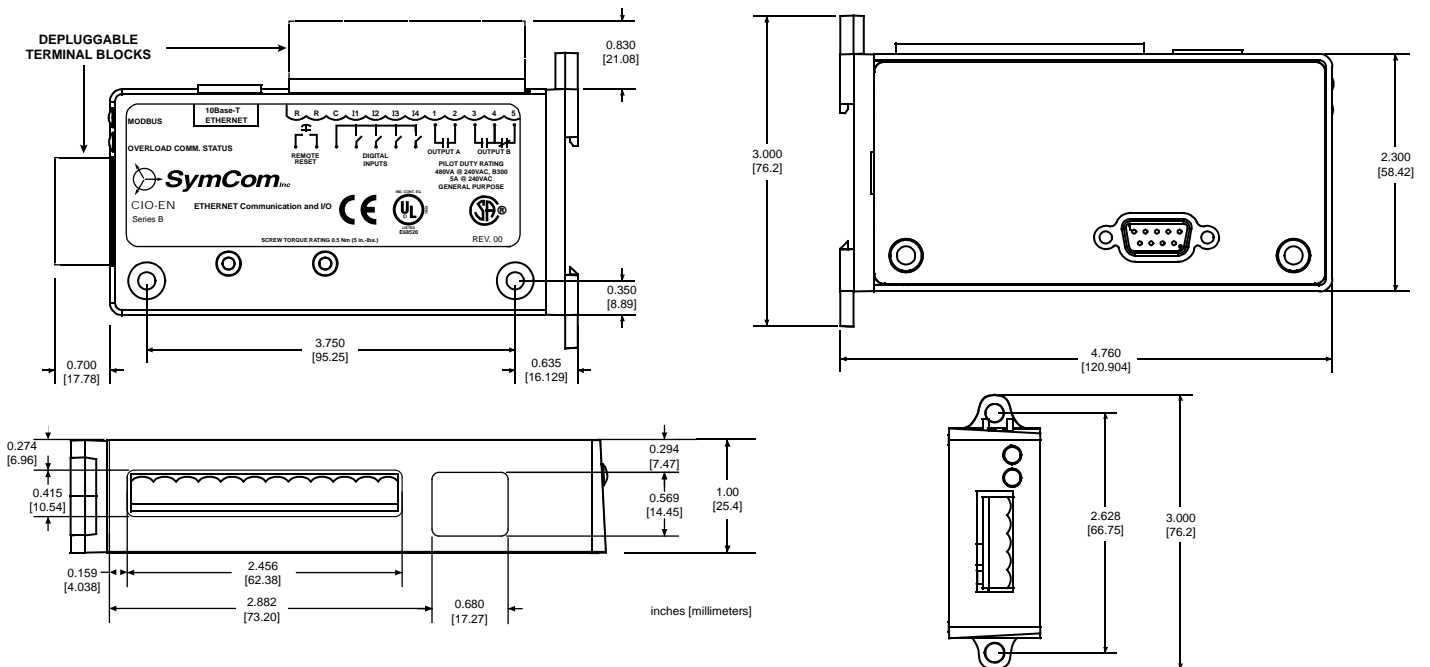

Figure 4 (RM-1000)

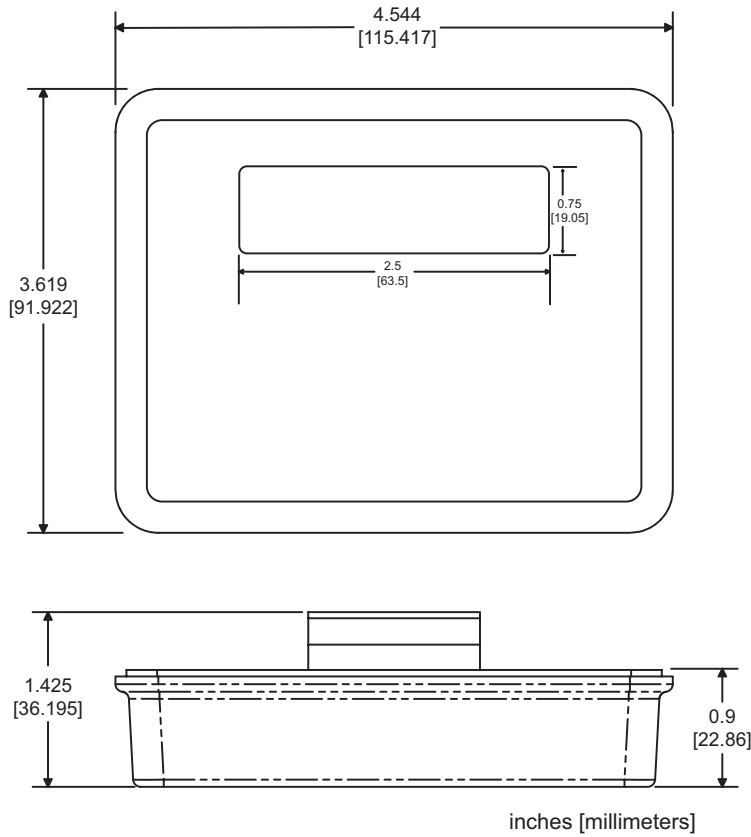
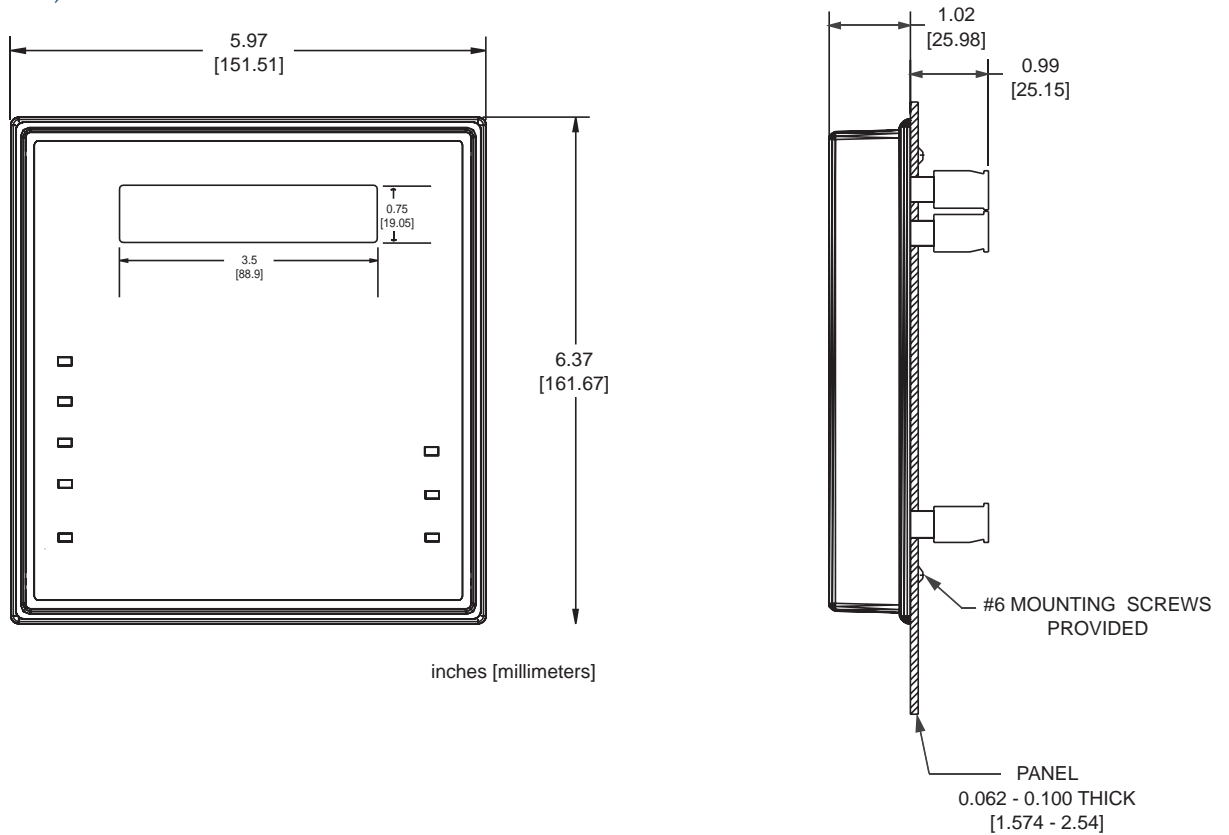

Figure 5 (RM-2000)



Appendix A - Dimensional Drawings

Figure 6 (80)

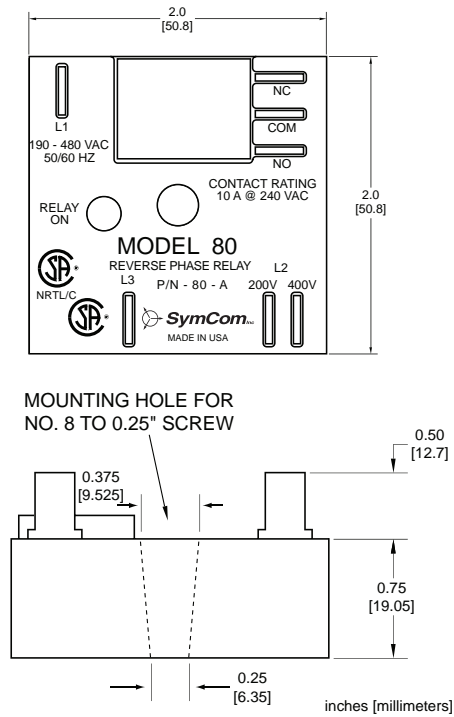

Figure 7 (102, 250, 350, 355, 455, 50R, CP-5, T10)

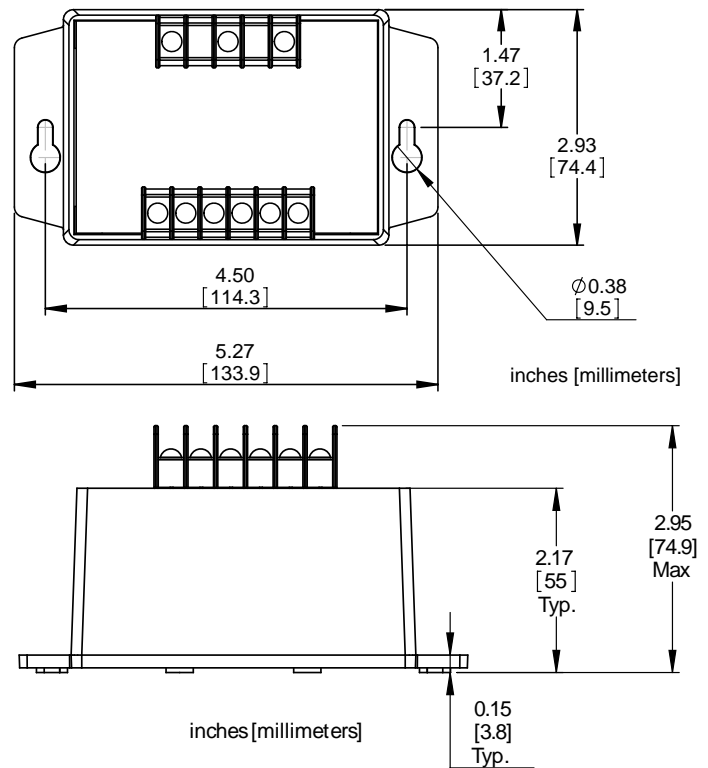

Figure 8 (ALT, 201, ISS-101, PC-LLC, ACBC-120)

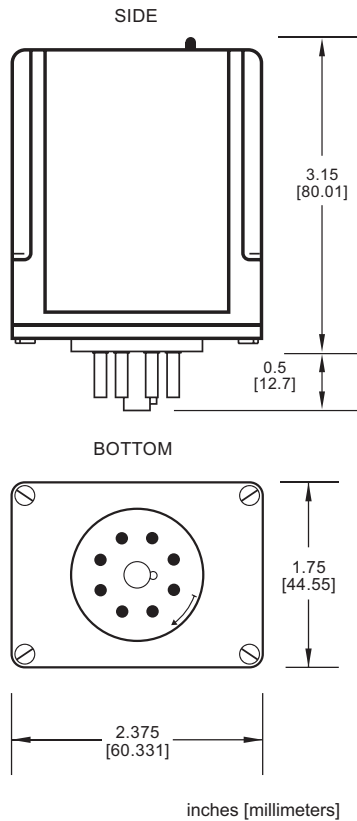

Figure 9 (202, 202-RP, 202-SP)

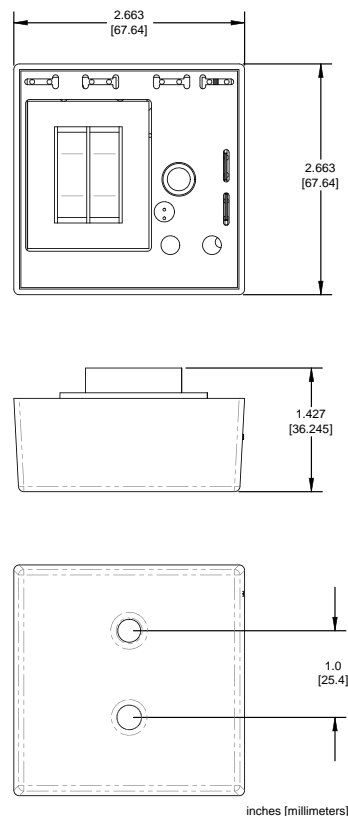

Figure 10 (Informer, Informer-MS)

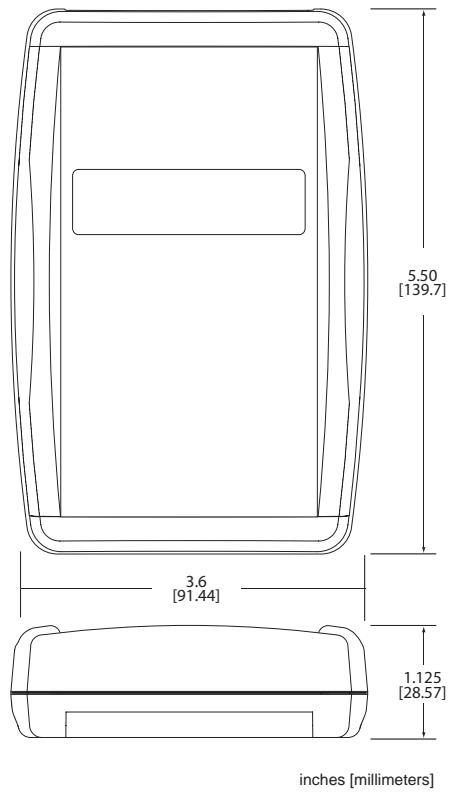

Figure 11 (460, ISS-100, ISS-102, PC-102)

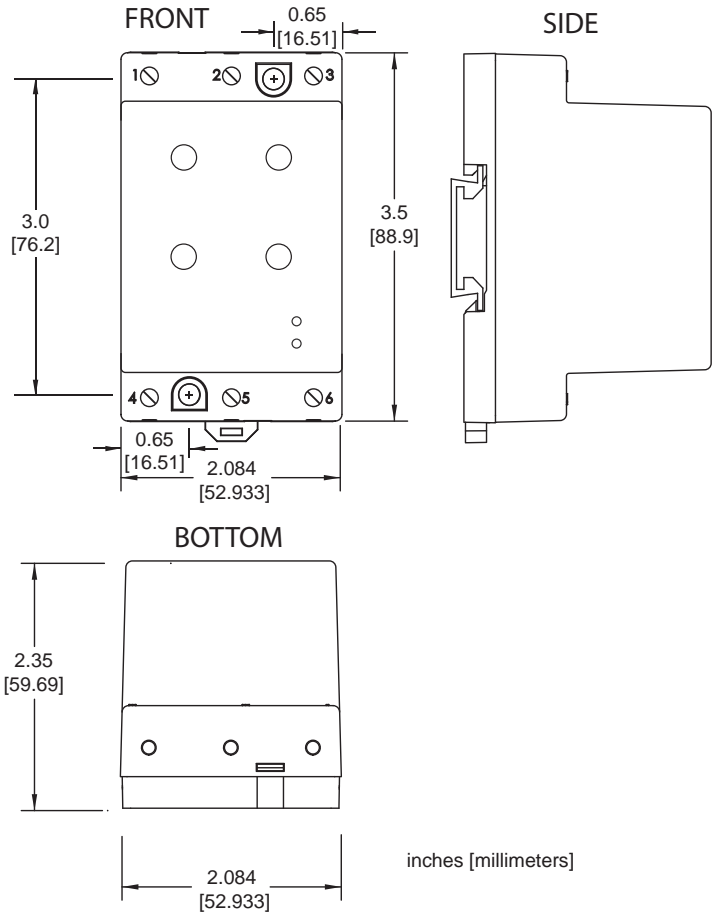
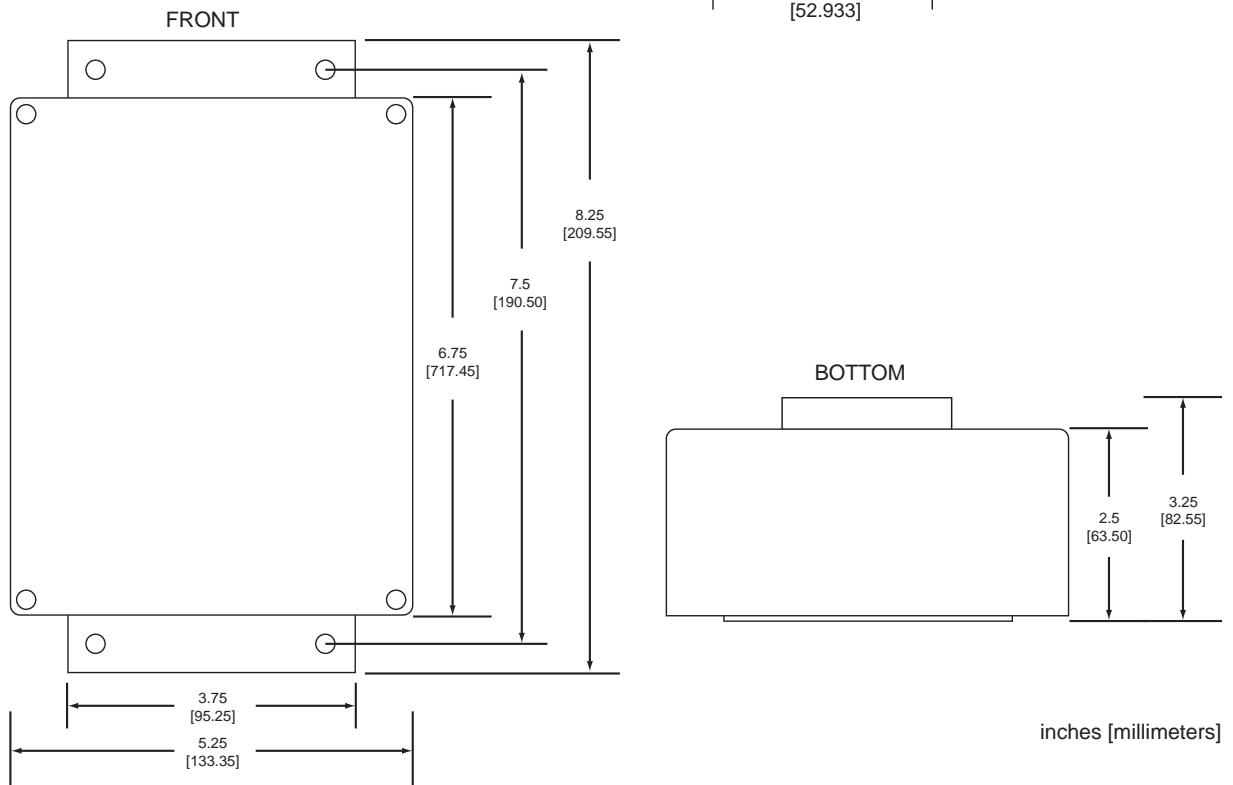

Figure 12 (520-CP, 520-CS)



Appendix A - Dimensional Drawings

Figure 13 (ISS-105, PC-105)

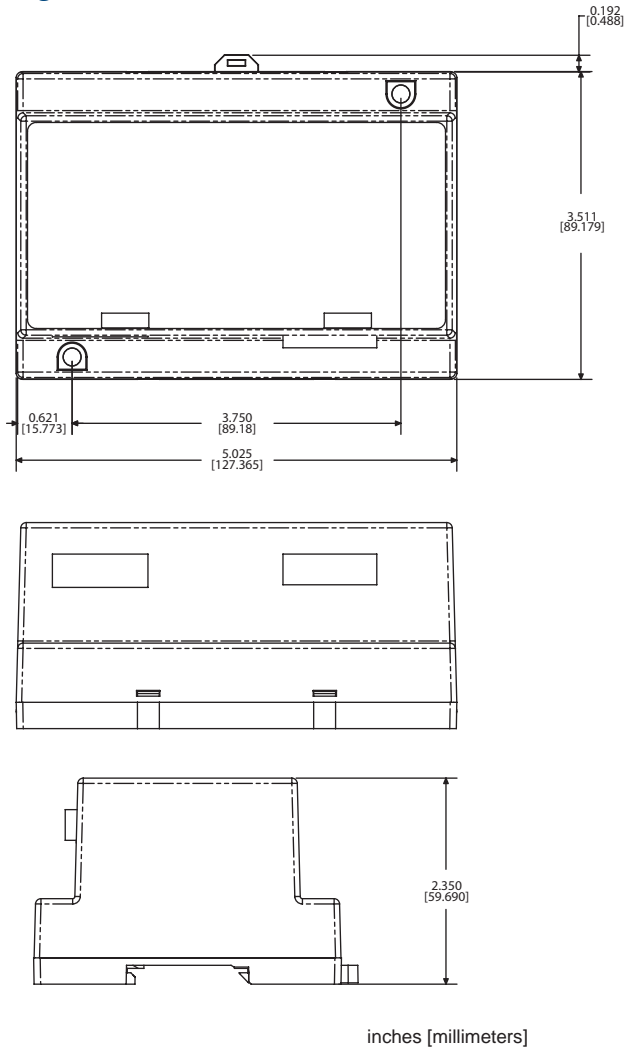

Figure 14 (LSR, LSR-0, LS-524, LSRU)

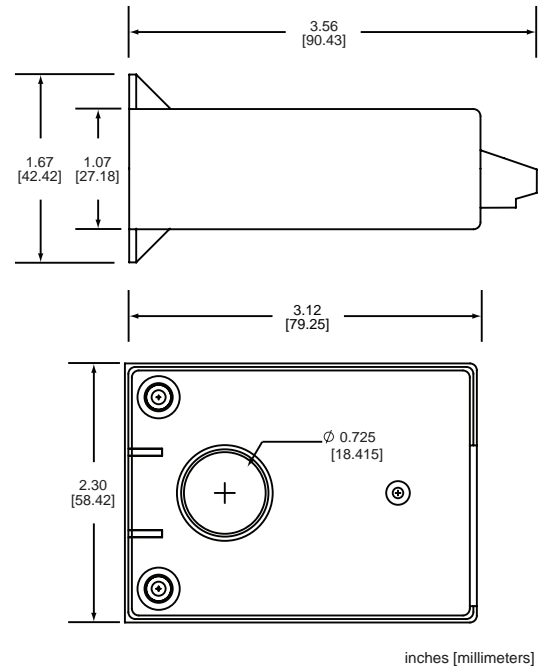

Figure 15 (LSRX)

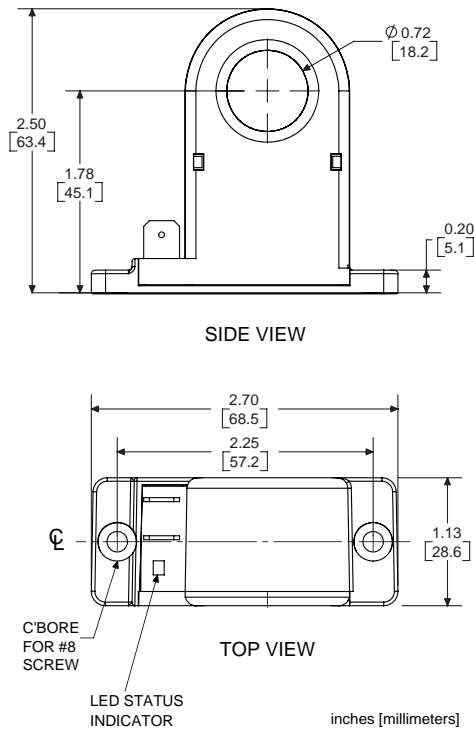

Figure 1

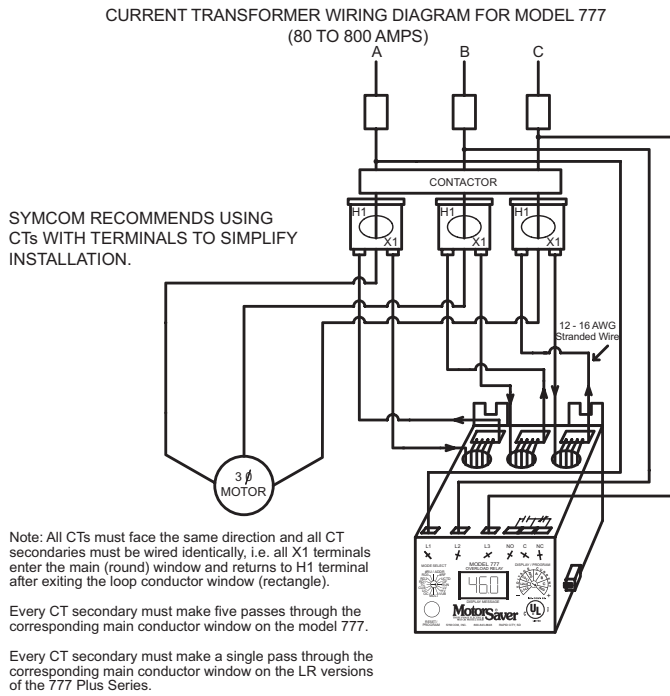

Figure 2

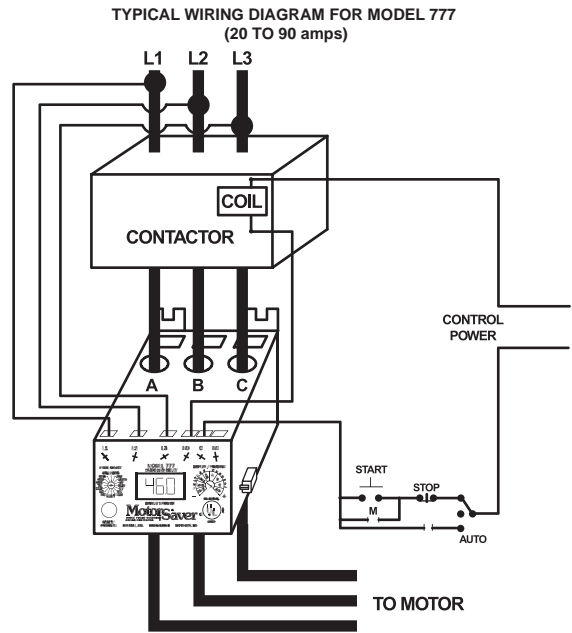

Figure 3

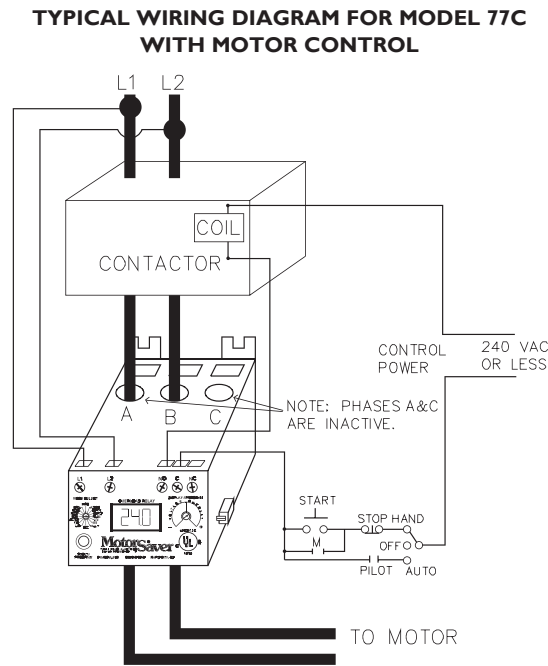
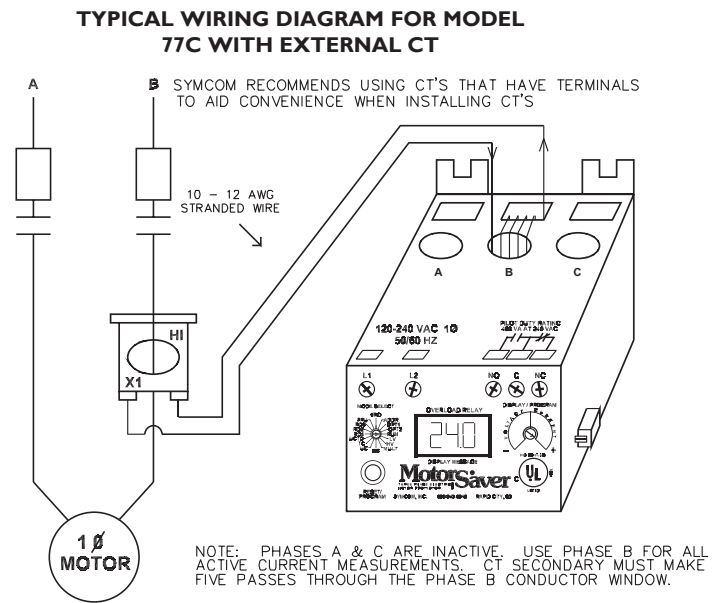

Figure 4



Appendix B - Typical Wiring Diagrams

Figure 5

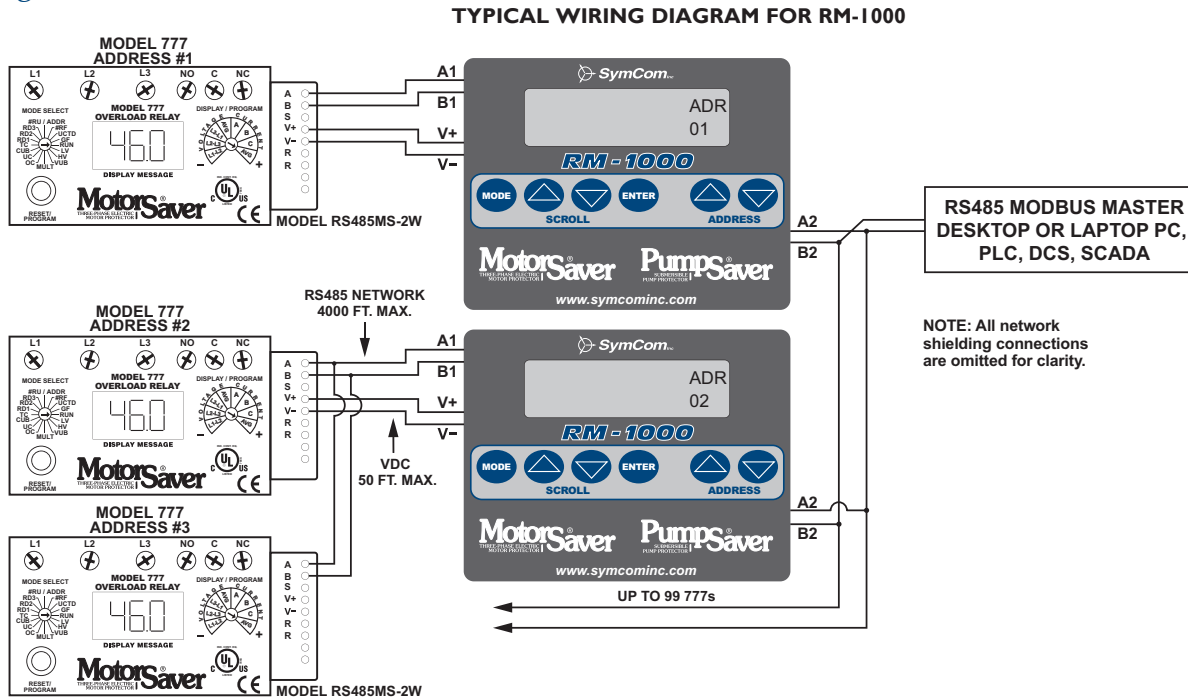

Figure 6

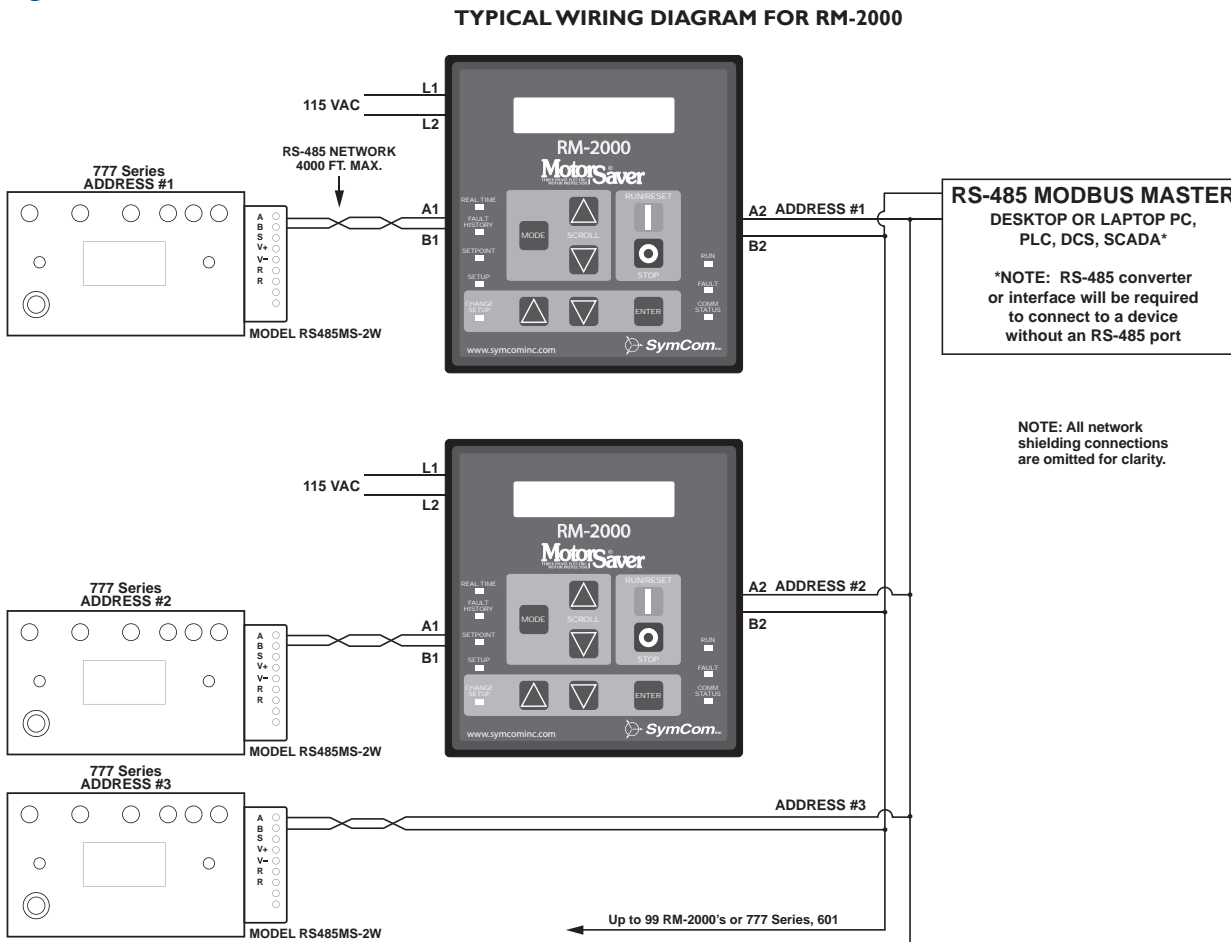

Figure 7

TYPICAL WIRING DIAGRAM FOR MODEL 601-CS-D-PI

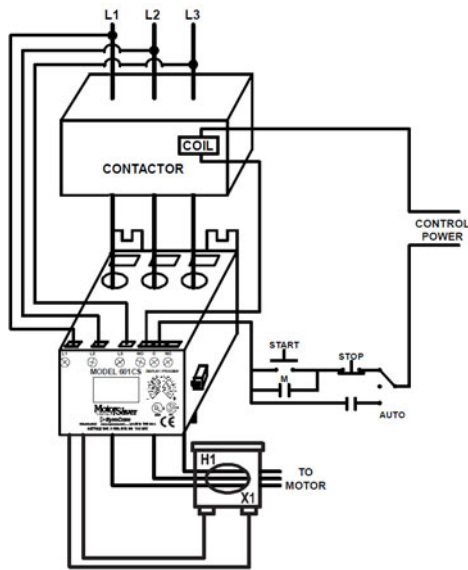

Figure 8

TYPICAL WIRING DIAGRAM FOR MODEL 80 (400VAC)

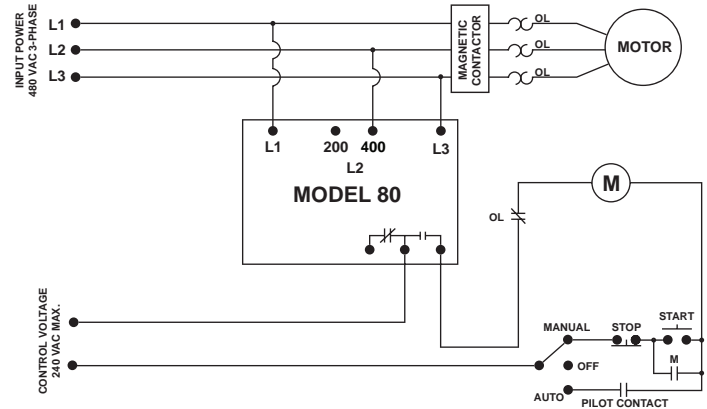

Figure 9

TYPICAL WIRING DIAGRAM FOR MODEL 80 (200VAC)

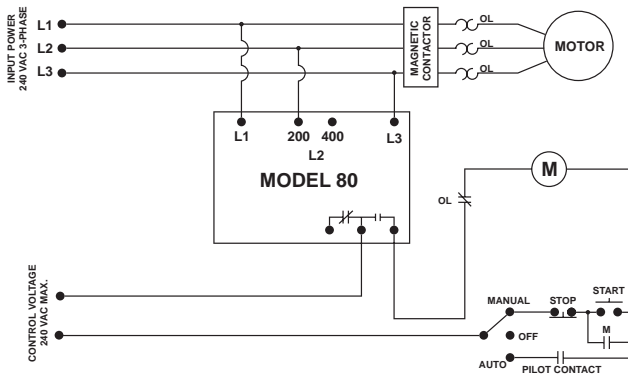

Figure 10

TYPICAL WIRING DIAGRAM FOR MODEL 102 WITH MOTOR CONTROL

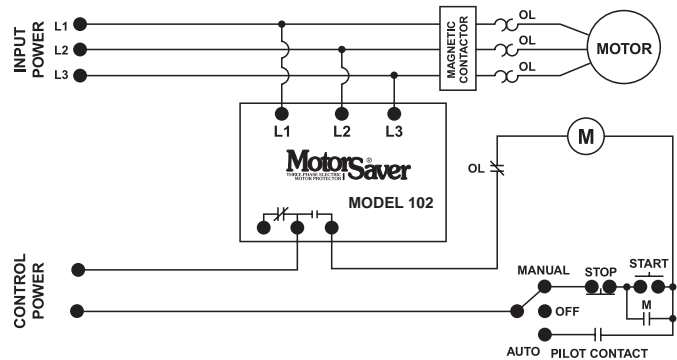

Figure 11

TYPICAL WIRING DIAGRAM FOR MODEL 102 WITH ALARM CONTROL

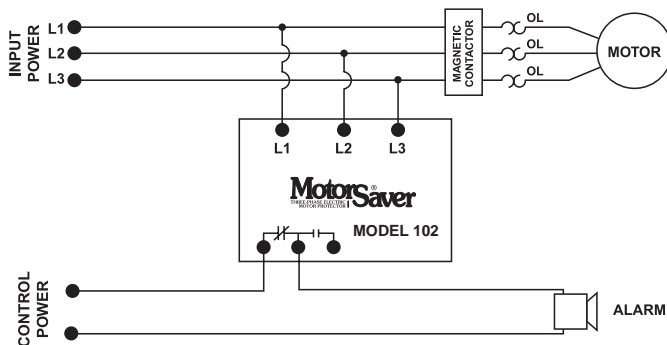
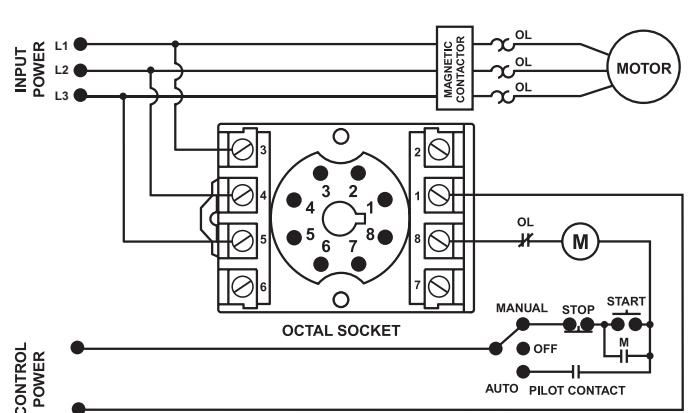

Figure 12

TYPICAL WIRING DIAGRAM FOR MODEL 201A WITH MOTOR CONTROL



Appendix B - Typical Wiring Diagrams

Figure 13

TYPICAL WIRING DIAGRAM FOR MODEL 201A WITH ALARM CONTROL

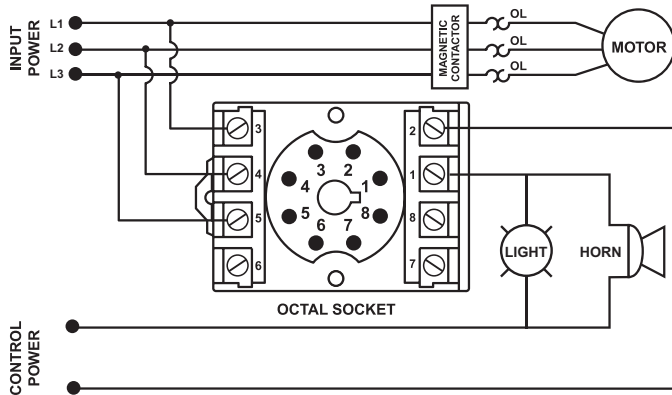

Figure 14

TYPICAL WIRING DIAGRAM FOR MODEL 201A-AU WITH MOTOR CONTROL

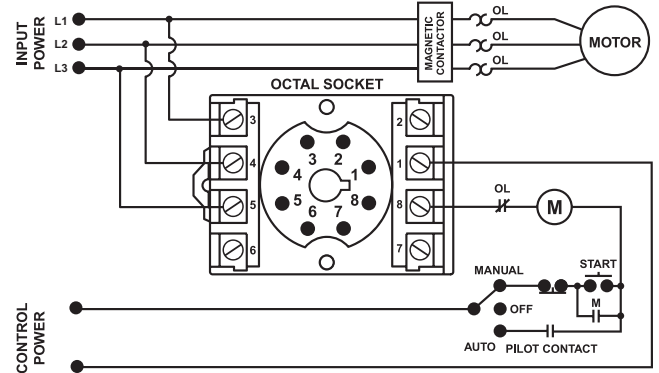

Figure 15

TYPICAL WIRING DIAGRAM FOR MODEL 201A-AU WITH ALARM CONTROL

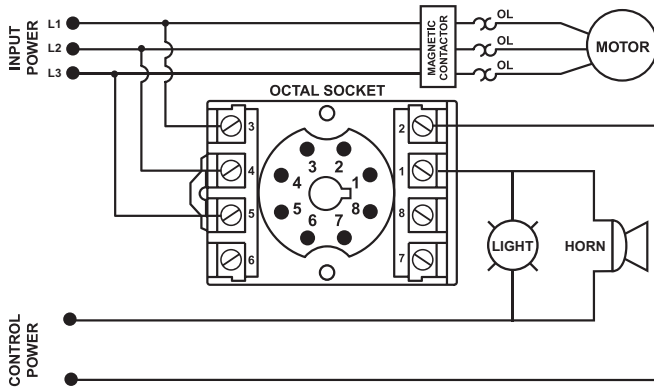

Figure 16

TYPICAL WIRING DIAGRAM FOR MODEL 201-xxx-DPDT

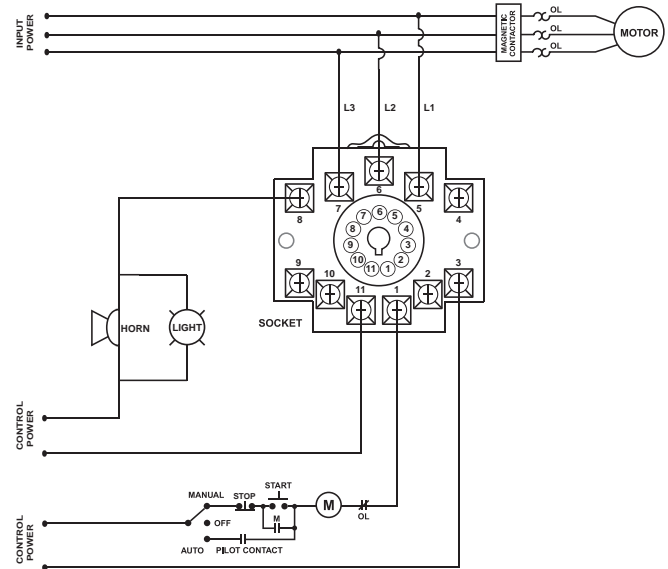

Figure 17

TYPICAL WIRING DIAGRAM FOR MODEL 202 WITH MOTOR CONTROL

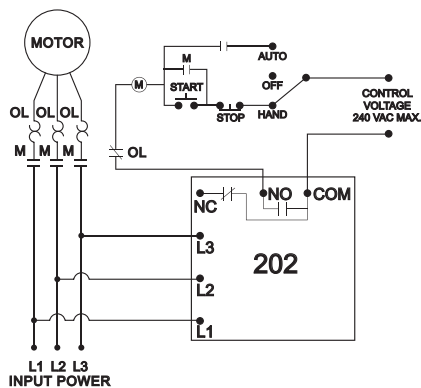

Figure 18

TYPICAL WIRING DIAGRAM FOR MODEL 202 WITH ALARM CIRCUIT

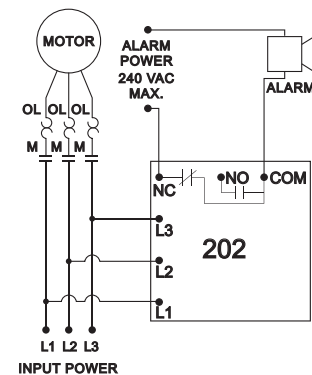

Figure 19

TYPICAL WIRING DIAGRAM FOR MODEL 250A

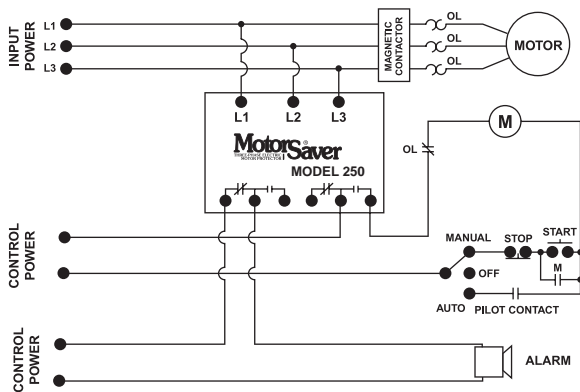

Figure 20

TYPICAL WIRING DIAGRAM FOR MODEL 350 WITH MOTOR CONTROL

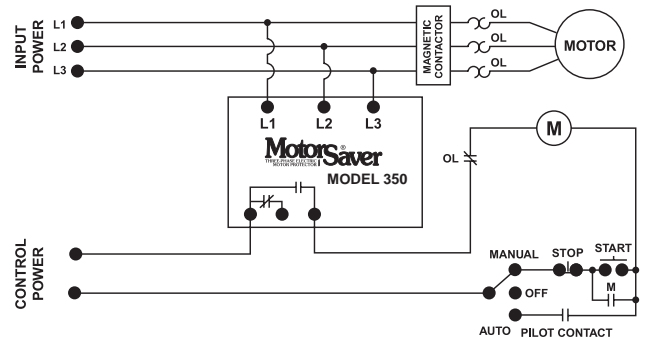

Figure 21

TYPICAL WIRING DIAGRAM FOR MODEL 355 WITH MOTOR CONTROL

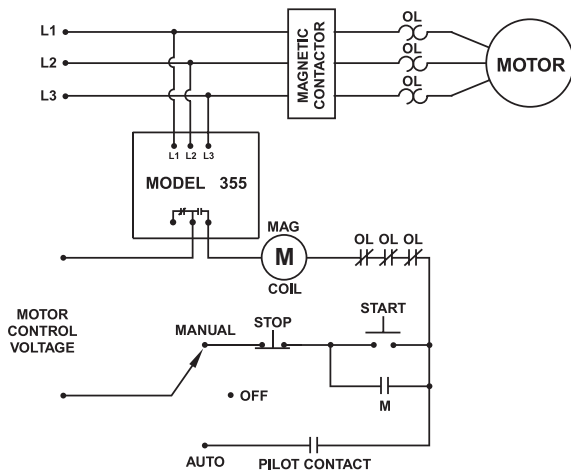

Figure 22

TYPICAL WIRING DIAGRAM FOR MODEL 355 WITH ALARM CONTROL

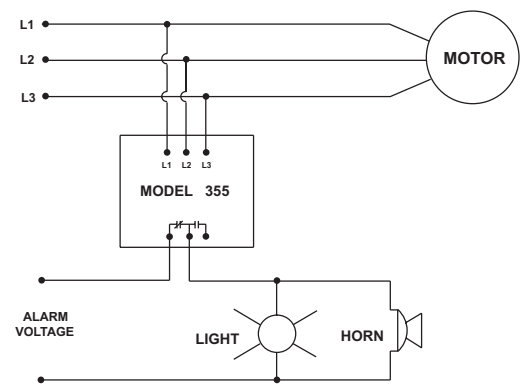

Figure 23

TYPICAL WIRING DIAGRAM FOR MODEL 455 WITH MOTOR CONTROL USING A 3-POLE CONTACTOR

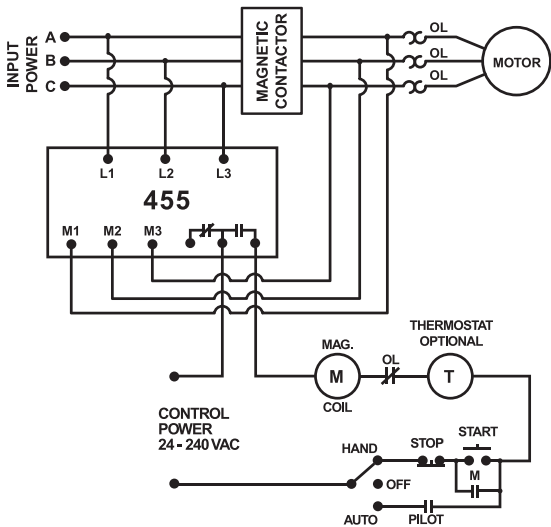
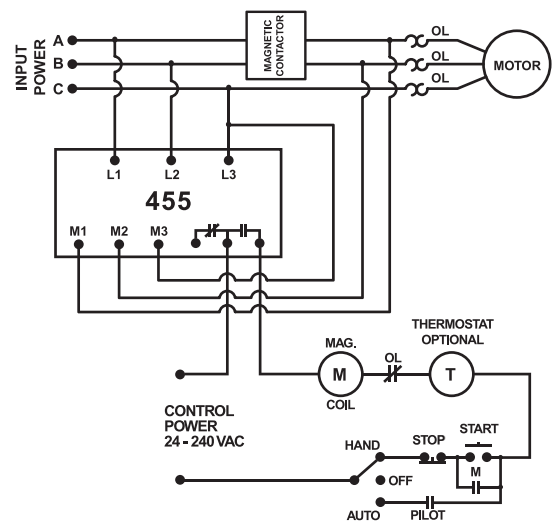

Figure 24

TYPICAL WIRING DIAGRAM FOR MODEL 455 WITH MOTOR CONTROL USING A 2-POLE CONTACTOR



Appendix B - Typical Wiring Diagrams

Figure 25

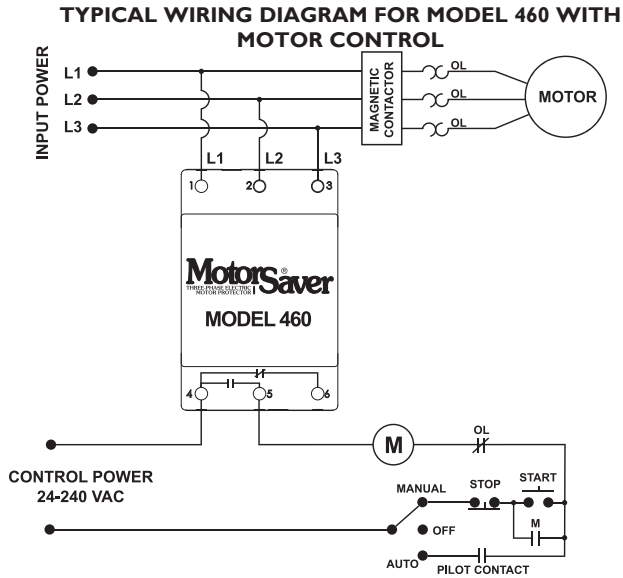

Figure 26

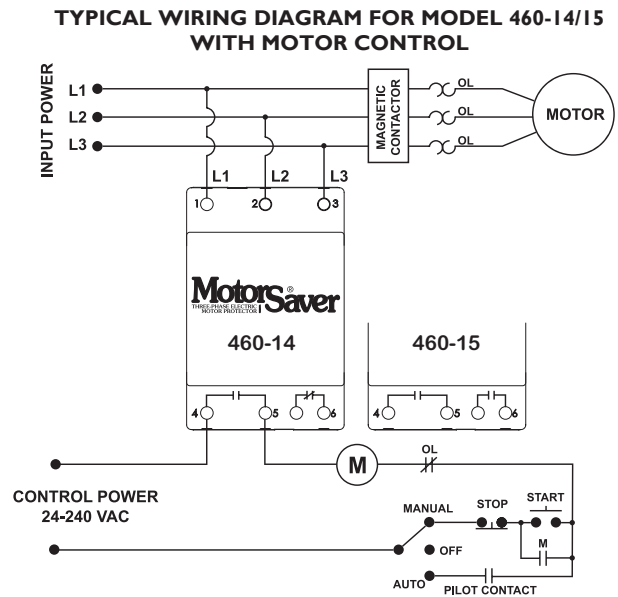

Figure 27

TYPICAL WIRING DIAGRAM FOR MODEL 601 WITH MOTOR CONTROL

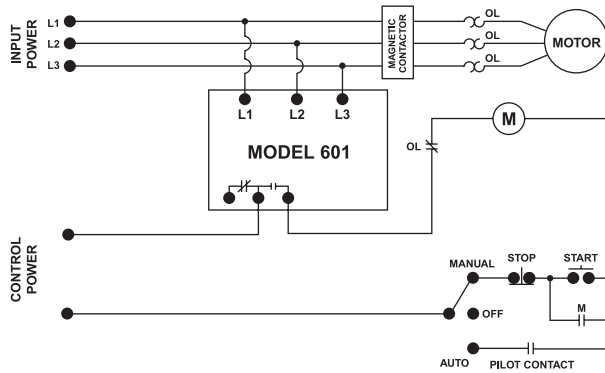

Figure 28

TYPICAL WIRING DIAGRAM FOR MODEL 50R WITH MOTOR CONTROL

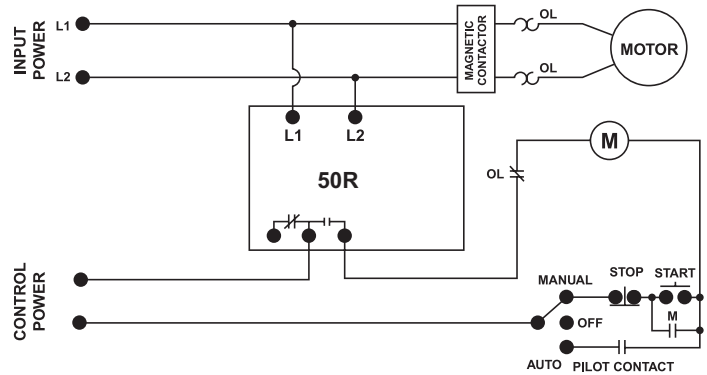

Figure 29

TYPICAL WIRING DIAGRAM FOR MODEL 201-SP WITH MOTOR CONTROL

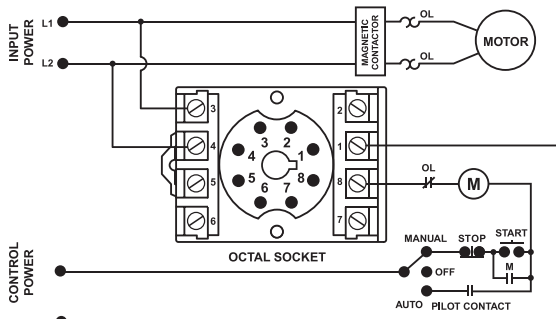
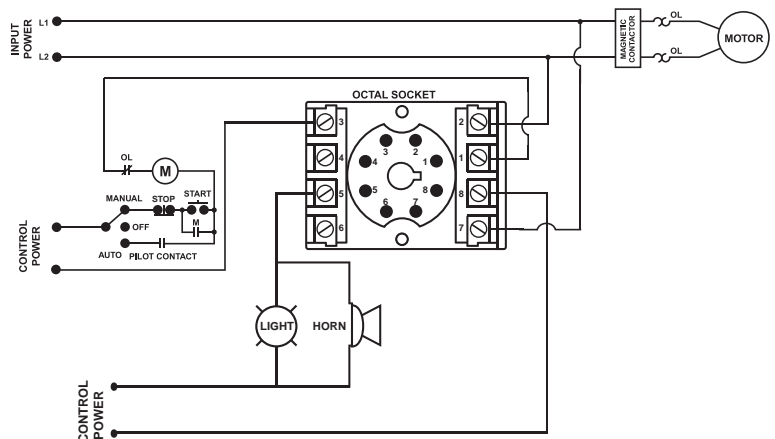

Figure 30

TYPICAL WIRING DIAGRAM FOR MODEL 201-xxx-SP-DPDT



Appendix B - Typical Wiring Diagrams

Figure 31

TYPICAL WIRING DIAGRAM FOR MODEL 202-200-SP WITH MOTOR CONTROL

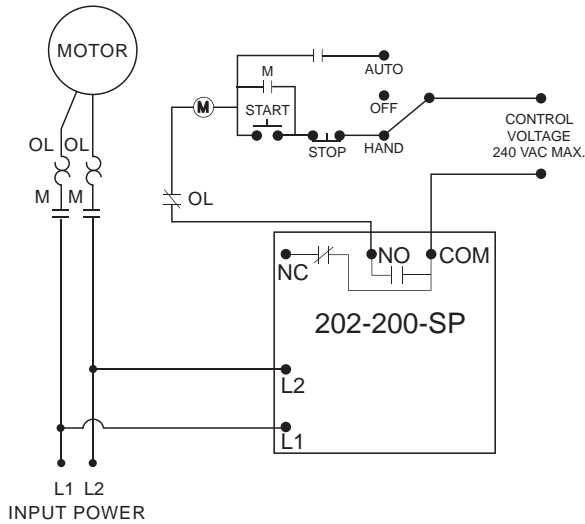

Figure 32

TYPICAL WIRING DIAGRAM FOR MODEL 202-200-SP WITH ALARM CONTROL

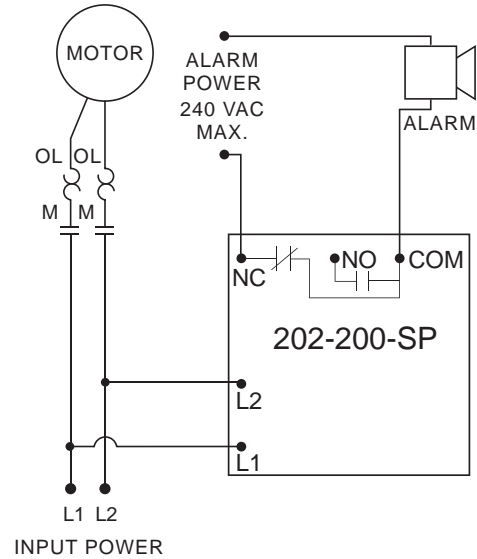

Figure 33

TYPICAL WIRING DIAGRAM FOR MODEL 460-xxx-SP WITH MOTOR CONTROL

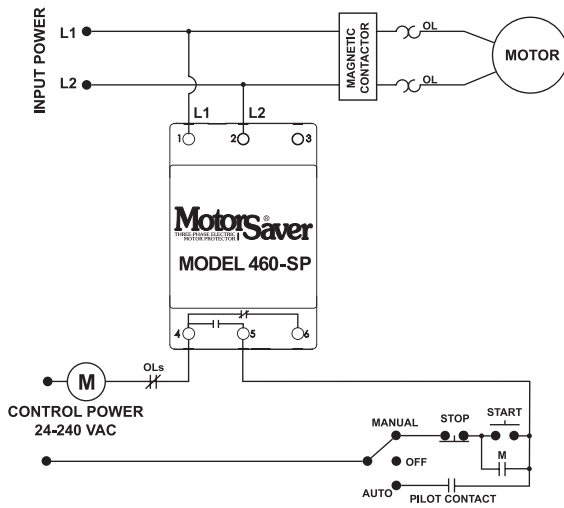
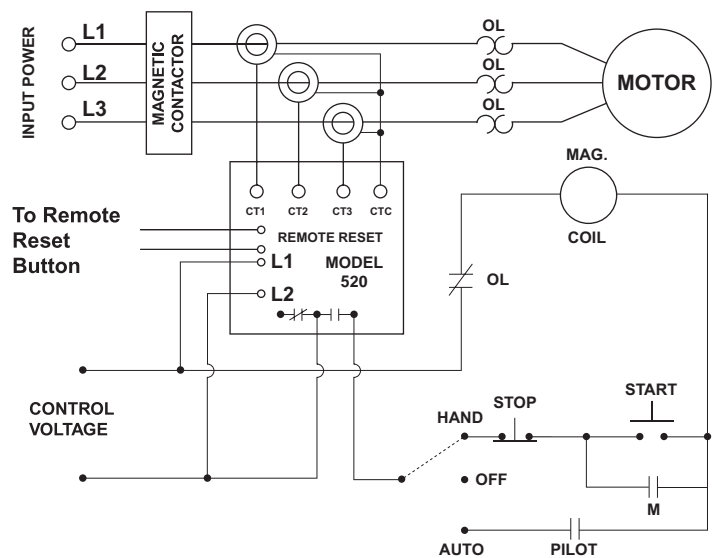

Figure 34

TYPICAL WIRING DIAGRAM FOR MODEL 520 WITH MOTOR CONTROL



Appendix B - Typical Wiring Diagrams

Figure 35

TYPICAL WIRING DIAGRAM FOR PC-102CICI-DL

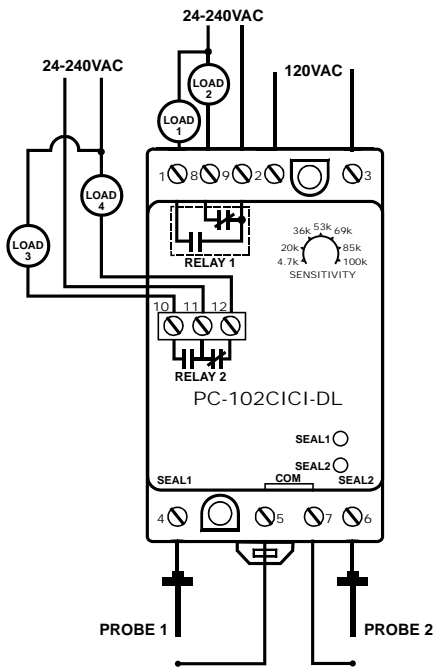

Figure 36

TYPICAL WIRING DIAGRAM FOR PC-102CICI-LT

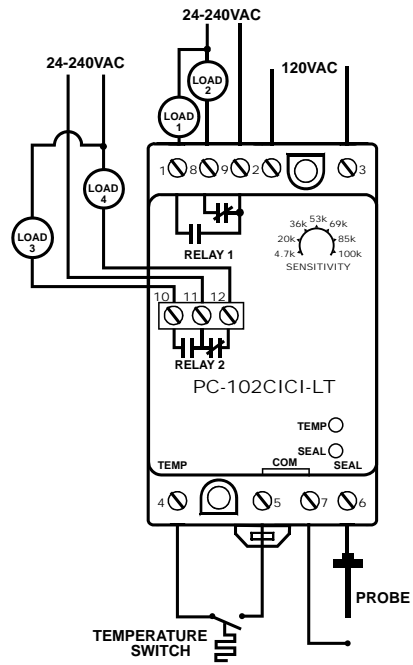

Figure 37

TYPICAL WIRING DIAGRAM FOR PC-xxx-LLC-CZ

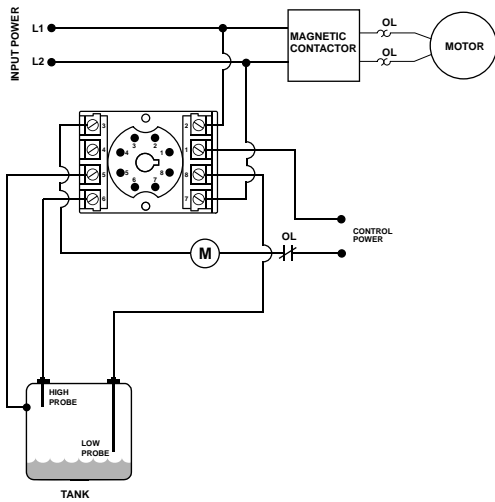

Figure 38

TYPICAL WIRING DIAGRAM FOR PC-xxx-LLC-GM

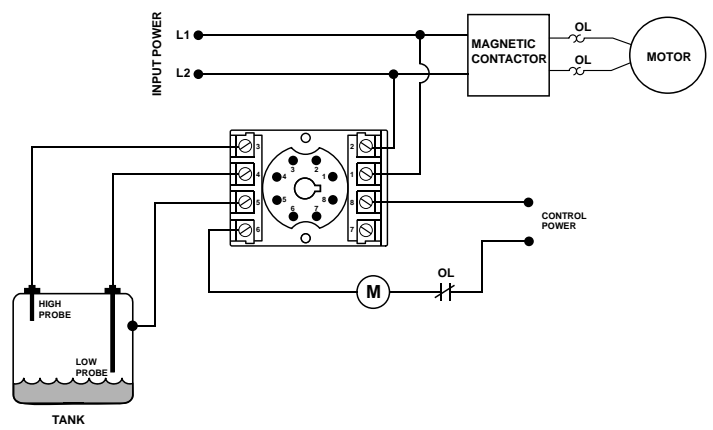

Figure 39

TYPICAL WIRING DIAGRAM FOR MODEL 460-15-100-LLS

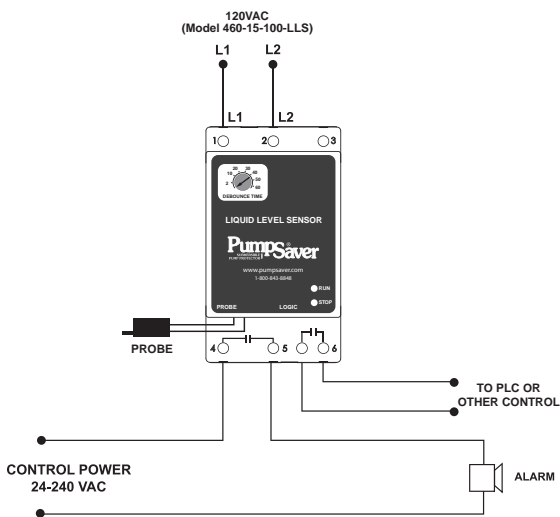

Figure 40

TYPICAL WIRING DIAGRAM FOR MODEL 460-15-100-SLD

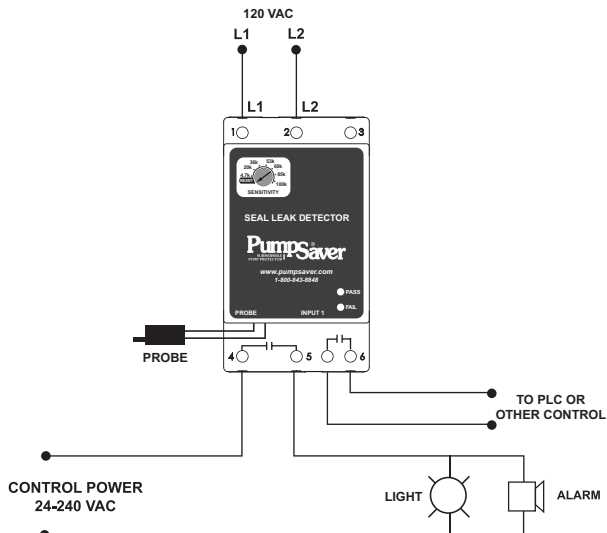

Figure 41

TYPICAL WIRING DIAGRAM FOR MODEL 201-xxx-SLD

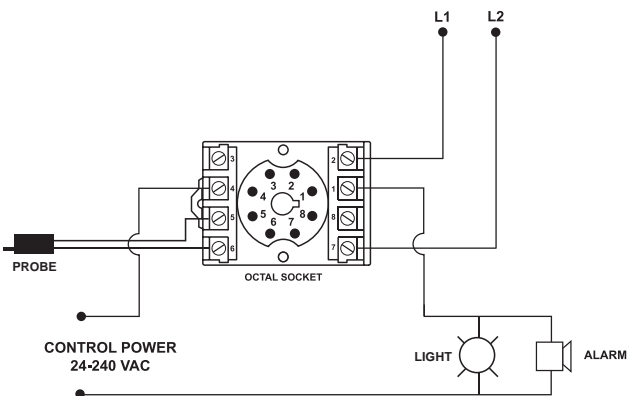

Figure 42

TYPICAL WIRING DIAGRAM FOR MODEL ALT-S

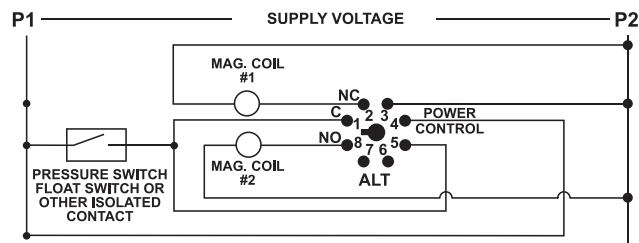

Figure 43

TYPICAL WIRING DIAGRAM FOR A MODEL ALT-X (CROSS CONNECTED)

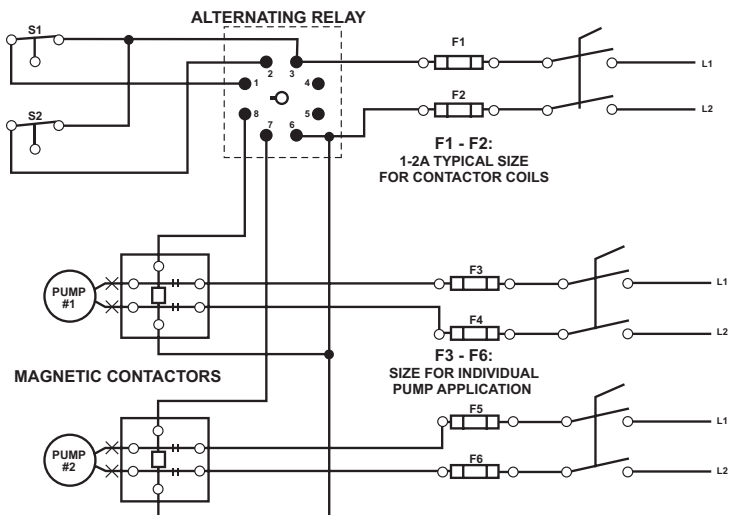
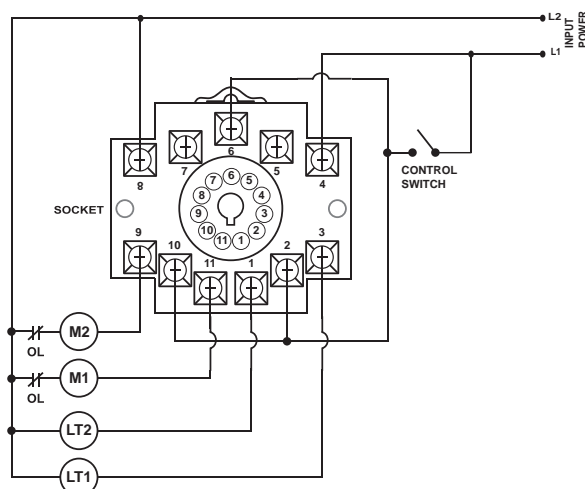

Figure 44

TYPICAL WIRING DIAGRAM FOR ALT-xxx-I-SW



Appendix B - Typical Wiring Diagrams

Figure 45

TYPICAL WIRING DIAGRAM FOR ALT-xxx-3-SW

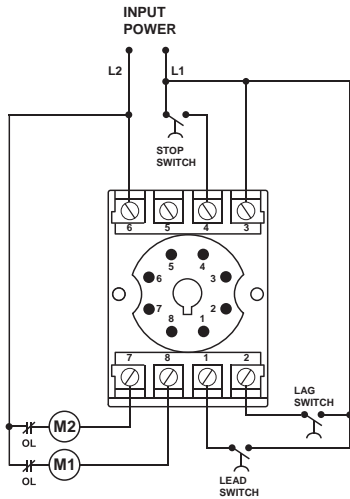

Figure 46

TYPICAL WIRING DIAGRAM FOR MODEL 50R-400-ALT

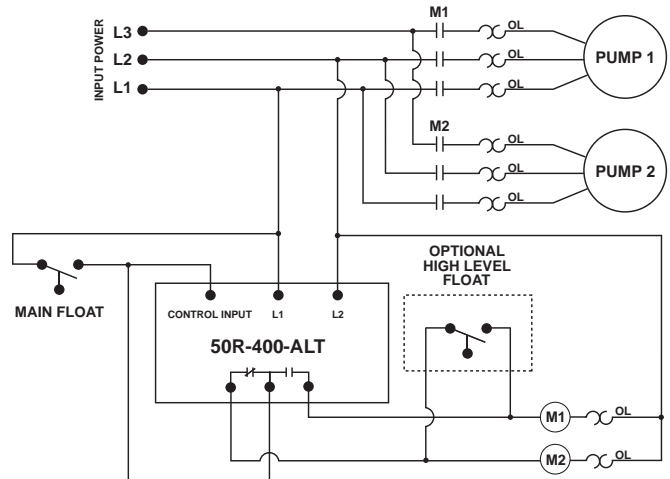

Figure 47

TYPICAL WIRING DIAGRAM ACBC-120

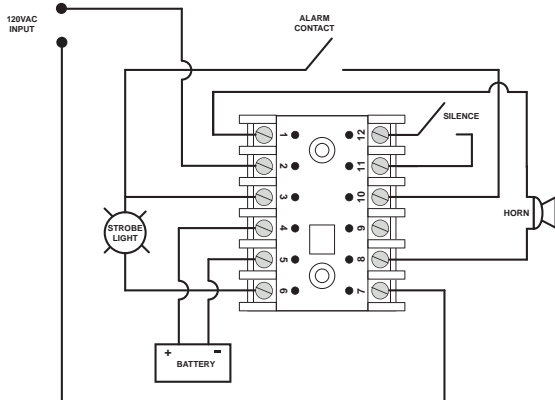
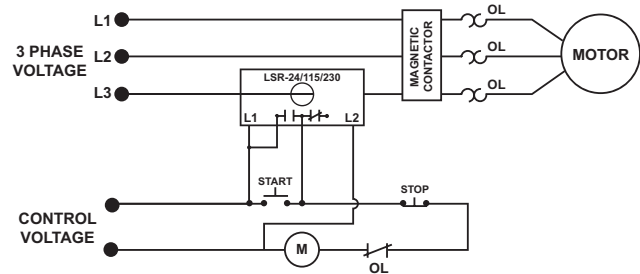

Figure 48

TYPICAL WIRING DIAGRAM FOR LOAD LOSS DETECTION



TYPICAL WIRING DIAGRAM FOR OVERLOAD DETECTION

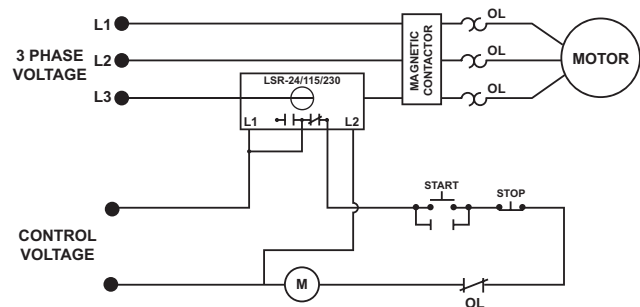

Figure 49

TYPICAL WIRING DIAGRAM FOR MODEL LSRU

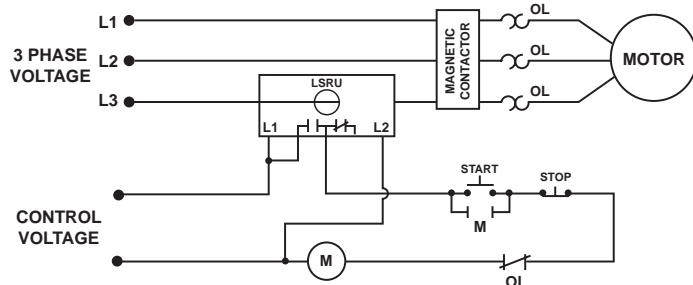

Figure 50

TYPICAL WIRING DIAGRAMS FOR MODEL LSR-0

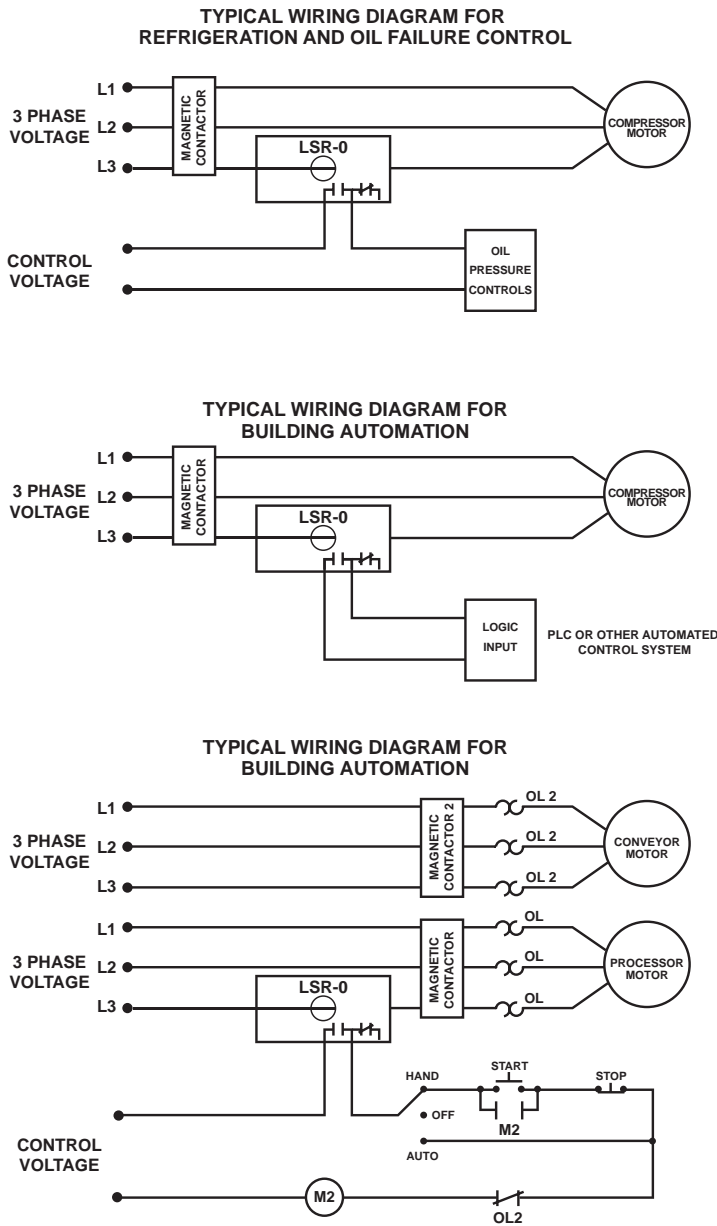

Figure 51

TYPICAL WIRING DIAGRAM FOR MODEL T-10

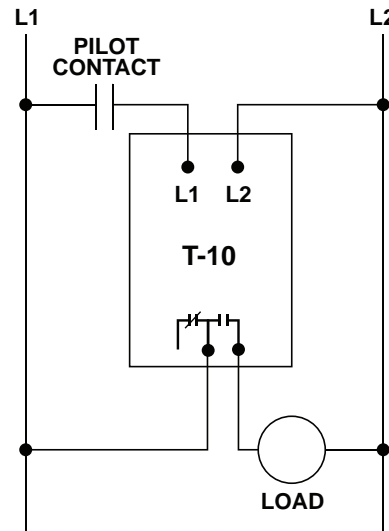
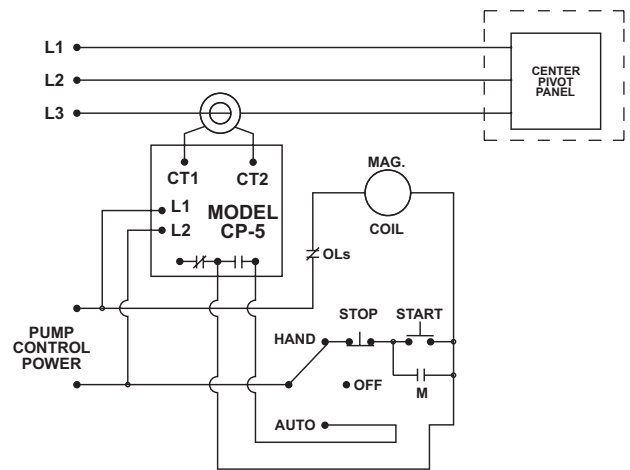

Figure 52

TYPICAL WIRING DIAGRAM FOR MODEL CP-5



NOTES

NOTES

NOTES