



Low voltage AC drives

ABB machinery drives ACS380, ACS880 0.25 to 45 kW/0.37 to 60 hp Catalog



What does all-compatible mean for you?

The idea behind all-compatible is simple: the better a drive fits to your processes, users and business and environmental goals, the faster you start enjoying the benefits it brings.

During drive selection, you save time as the drives have many built-in features simplifying the selection process. A broad range of options provide easy extension to the drive's functionality. The simplicity carries on to the drive setup and commissioning. With a state of the art user interface and drive design, installation and setup is made easy and optimal.

The total cost of ownership and your impact on the environment is lower with the drives ensuring your processes run efficiently and reliably. The control panel and PC tool enable you to monitor and analyze the drives. As a result,

you can fine tune them to get more out of the drives and process using less energy.

The ACS380 and ACS880 machinery drives are part of ABB's all-compatible drives portfolio. Together with other all-compatible drives they share the same architecture and user interfaces, yet there is an optimal drive for virtually any application.

Once you have used one all-compatible drive, you can use them all. Your knowledge accumulates with each new installation, resulting in more efficient processes and business.

That's it. In short, all-compatible means better business sense.

Contents

4	The all-compatible machinery drives
6	Versatile virtuosity for machine building
8	Human all-compatible
9	Process all-compatible
10	Environment all-compatible
11	Business all-compatible
12	Technical data
13	How to select a drive
14	Persistent predictability with ACS380 machinery drives
15	ACS380 ratings, types and voltages
16	Adaptable performance with ACS880 machinery drives
17	ACS880 ratings, types and voltages
18	Connectivity and flexibility to meet your needs
20	Standard software with versatile features
21	Drive Application programming based on IEC standard 61131-3 for ACS880 machinery drives
22	Application control programs for ACS880 machinery drives
24	PC tool for drive monitoring and process tuning capabilities
24	Remote monitoring access worldwide
25	Drive commissioning and adaptable use with your control panel
26	Flexible connectivity to automation networks
27	Standard interface and extensions for ACS380 machinery drives
28	Standard interface and extensions for ACS880 machinery drives
29	Input/output, extension and feedback modules for increased connectivity
30	Integrated safety reduces costs for ACS880 machinery drives
32	Brake options
32	EMC – electromagnetic compatibility
33	Need a motor? This is our offering.
34	Drives service
36	Contact us

Adaptability that will
bring a smile to your face



The all-compatible machinery drives

The ACS380 and ACS880 machinery drives are easy to adapt and configure to machines in a persistent and adaptable manner.

The drives control constant torque applications such as conveyors, mixers, extruders, winders, warehouse lifts and overhead cranes in the food and beverage and material handling industries. They require little setting up or commissioning. In addition to the intuitive control panel, the ACS380 offers a control panel with an icon based menu for easy and smart commissioning of the drive, getting the drive ready for action. The drive is easy to connect to automation systems. All the essential features are built-in as standard, which reduces the need for additional hardware and simplifies drive selection.

Persistent predictability

The ACS380 machinery drive is a robust and compact drive ideal for machine building. Ready customized it comes in a power range from 0.25 to 7.5 kW, and voltages from 200 to 240 V (one-phase) and 380 to 480 V (three-phase).

The drive has enclosure class IP20 as standard. The drive offers EMC and connectivity variants for ease of integration and connectivity appreciated by machine builders that install hundreds of drives per year. There is a fixed space in the machine for automation and motor control, and the drive needs to meet the space restrictions and connectivity requirements (fieldbus, I/O etc.). It really is one drive that fits different needs easy, from product customization to volume customers.

Adaptable performance

The ACS880 machinery drive is a high performance drive that provides machine builders adaptability and performance. Suitable for high-performance applications in machine building, it offers powers from 0.37 to 45 kW, and voltages from 230 to 500 V, with enclosure class IP20 as standard.

With ABB's premium motor control (DTC), the drive enables high static and dynamic motor speed accuracy even without a motor feedback device. Integrated safety features include safe torque off (STO). The optional safety functions module provides extended safety functions, simplifying configuration and reducing installation space. PROFI-safe over Profinet connectivity is possible between the drive and the PLC. The adaptive IEC 61131-3 programming capability offers additional flexibility in designing the control logic and integrating the drive to other automation devices. General motion control features improve precision performance of applications, providing flexible tools for optimized machine building.

Persistent and adaptable performance



Versatile virtuosity for machine building

The ACS380 and ACS880 machinery drives are part of ABB's all-compatible drives portfolio. The drives promise you persistent predictability and adaptable performance throughout their whole life cycle. The drives offer a wider range of standard and optional features for optimal machine building.



Adaptability at your fingertips

The control panel's menu helps you set up the drive quickly and effectively.

Simple to select, install and use

Built-in features such as an EMC filter, a Modbus RTU fieldbus interface and safe torque off functionality simplify drive selection, installation and use. DriveSize helps to select the optimal drive and motor for the application.



Communication with all major automation networks

Preconfigured fieldbus adapters enable connectivity with all major industrial automation networks.





Wide range of safety features

The optional safety functions module provides for ACS880 drives extended safety functions, simplifying the configuration and reducing installation space. The drive also supports PROFIsafe over Profinet connectivity between the drive and safety PLC.



Drive application programming

The ACS880 supports IEC 61131-3 programming in addition to the standard interfaces, and has a built-in slot for additional input/output extension modules.

Boosting energy efficiency

Energy optimizer and energy efficiency information help you monitor and save the energy used in your process.



Remote monitoring

With a built-in web server and standalone data logger, NETA-21 enables worldwide and secure remote access to drives.



Startup and maintenance tool

Drive composer PC tool for startup, configuration, monitoring and process tuning. Automation builder for automation engineering and Drive Manager for single point of commissioning.

Human all-compatible

The machinery drive is designed to save you time and energy during engineering, installation, commissioning and use.

When designing a machine, you will have a wide selection of design tools available to support your work. When you select a drive for your machine, you will save time with the straight forward configuration. The different variants of available control panels provide you a smart way to set up the drive quickly. One glance at the control panel's editable display will show you the status of the drive and its process.

The Drive composer PC tool provides extensive drive monitoring and process tuning capabilities. The Automation Builder is used both for engineering individual industry devices and putting together entire automation projects. It includes the Drive Manager tool, used for single point access to multiple drives in an automation network. Integrated safety functionality saves you time and cost in wiring and certification.



Drives adapt to your machine, not the other way round.

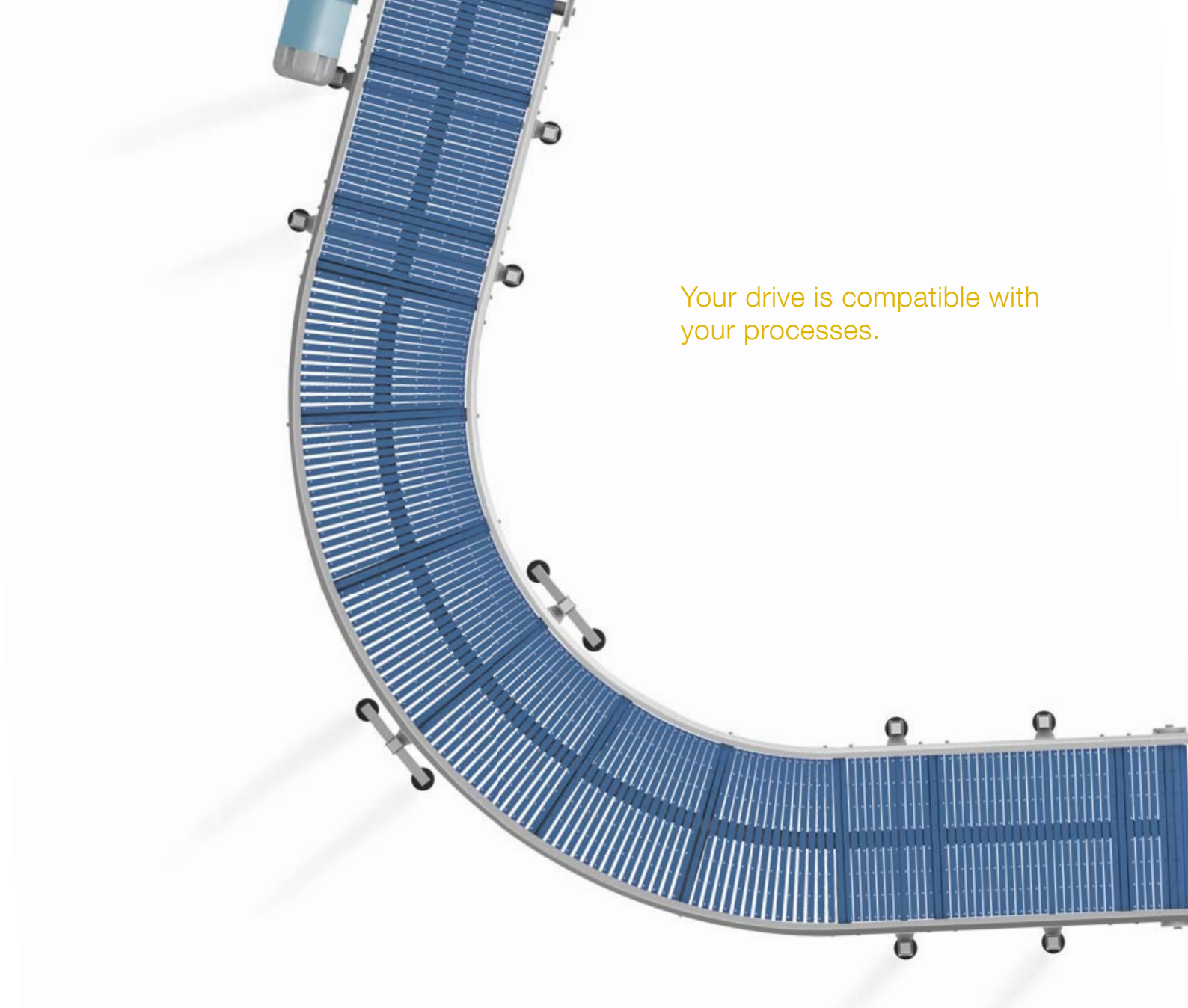

Your drive is compatible with
your processes.

Process all-compatible

The machinery drives are ready for a broad range of constant torque application and all essential features are built-in as standard. The drives support adaptive programming for fine tuning the performance of the application. The machinery drives offer a wide range of fieldbus protocols for extensive automation connectivity.

The drives cover a broad range of motors in various applications by providing adaptability and scalability for your machine and increasing its performance. With integrated safety features, you end up having a process which is not only efficient but safe for persons operating the machine and safe for your property.

Environment all-compatible

With ABB and the machinery drives, you are not only optimizing the energy consumption of an electric motor but also your whole process.

The machinery drives help you use only the exact amount of energy needed to run your motor. The energy optimizer feature ensures maximum torque per ampere, reducing energy drawn from the supply. The drive fulfills the highest IE2 drive (EN 50598-2) energy efficiency class and is compatible with high-efficiency IE4 motors, further reducing total life cycle costs. And the built-in energy efficiency calculators help you to analyze and optimize processes. With the help of our life cycle services, you will be able to keep your process running reliably and efficiently throughout the life cycle of the drives.

The greenest energy is the energy that you do not use. That is what your machinery drives allow you to do.

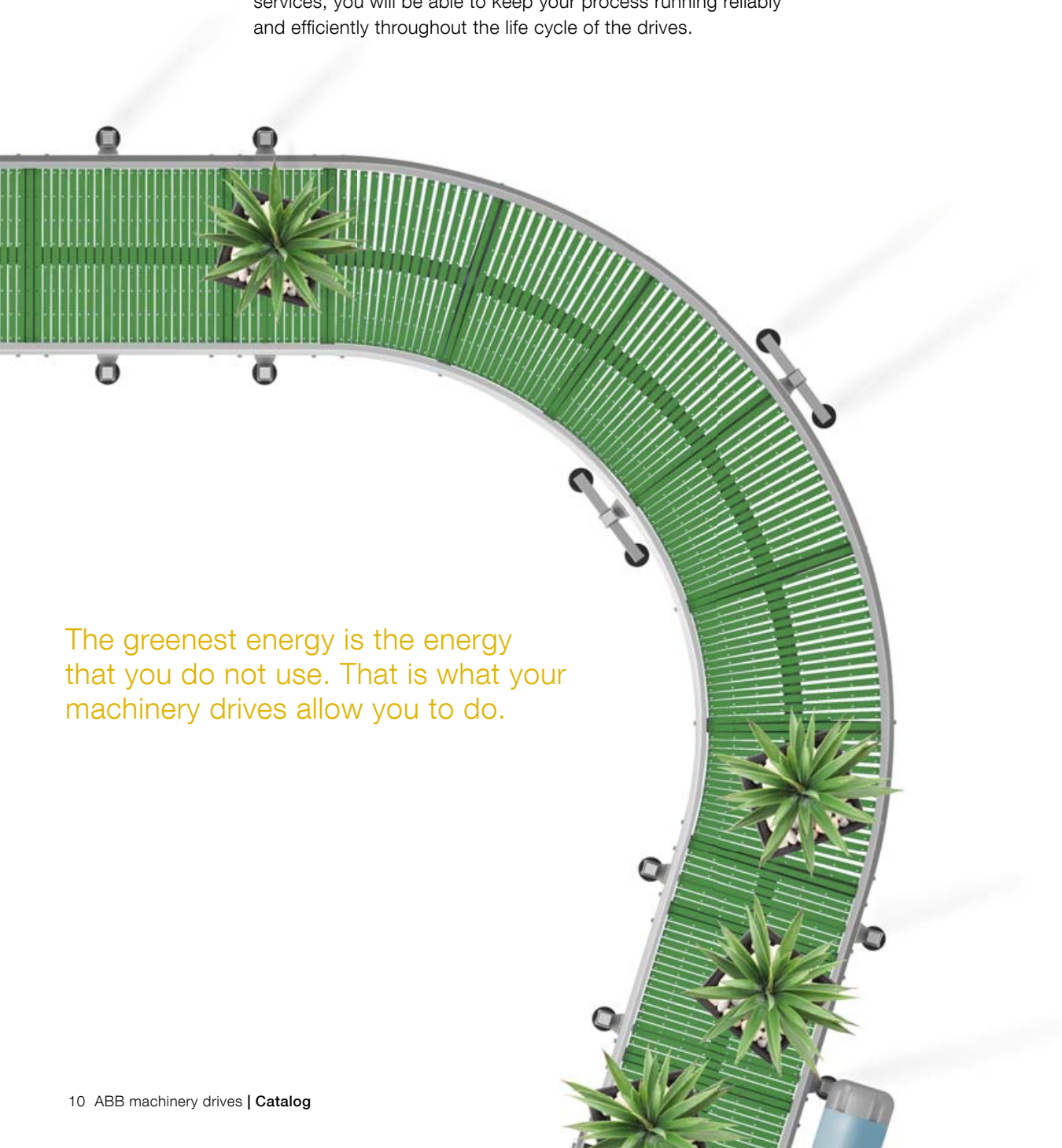

New technology inside, the whole ABB outside,
designed to support your business.

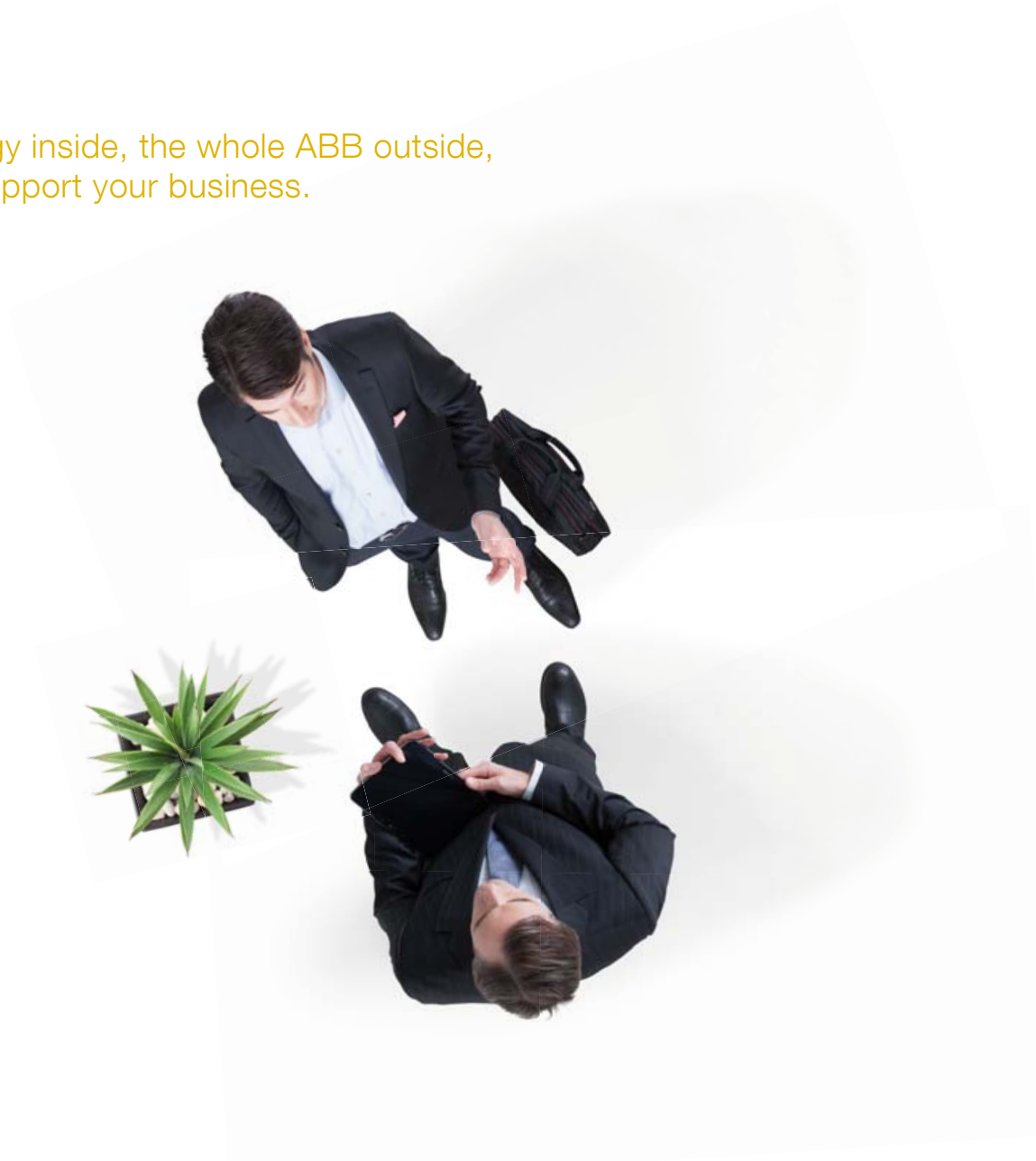

Business all-compatible

Usually, any drive is a justified investment that gives a short payback time by lowering energy consumption and helping improve productivity of the processes.

When you choose an all-compatible machinery drive from ABB, you get more than just a drive.

You get our services to support your business, including our decades of experience in various industries. ABB's local offices are in over 90 countries and our global value provider network members will be near to you.

Technical data

Mains connection		
Voltage and power range	ACS380	1-phase, 200 to 240 V, +10%/-15% 0.25 to 2.2 kW 3-phase, 380 to 480 V, +10%/-15% 0.25 to 7.5 kW
	ACS880	3-phase, 200 to 240 V, +10%/-15% 0.37 to 22 kW 3-phase, 380 to 500 V, +10%/-15% 0.37 to 45 kW
Frequency		50/60 Hz +/- 5%

Common DC connection		
DC voltage level	ACS380	-2 types 270 to 325 V ±10% -4 types 485 to 620 V ±10%
	ACS880	-2 types 270 to 325V ±10% -5 types 485 to 620V ±10%
Charging circuit		Internal charging circuit

Motor connection		
Voltage		0 to UN, 3-phase
Frequency		0 to 599 Hz
Motor control	ACS380	Scalar control Vector control
	ACS880	Direct torque control (DTC) Scalar control
Switching frequency	ACS380	1 to 16 kHz, default 4 kHz
	ACS880	DTC modulation 1 to 16 kHz, default 4 kHz
Dynamic braking		Flux braking (moderate or full) Resistor braking (optional)

Motor control performance		
Speed control performance, open loop		
Static accuracy	ACS380	20% of motor rated slip
	ACS880	10% of motor rated slip
Dynamic accuracy	ACS380	1% s with 100% torque step
	ACS880	<0.4% s with 100% torque step
Speed control performance, closed loop		
Static accuracy	ACS380	0.1% of motor rated speed
	ACS880	0.01% of motor rated speed
Dynamic accuracy	ACS380	<1% s with 100% torque step
	ACS880	<0.2% s with 100% torque step
Torque control performance		
Torque step rise time	ACS380	< 10 ms, rated torque step
	ACS880	< 5 ms, rated torque step
Non-linearity	ACS380	±5% with rated torque
	ACS880	less than ±4% with rated torque

Braking power connection		
Brake chopper		Built-in brake chopper as standard
Brake resistor		External resistor connected to drive

Functional safety		
Built-in safety features		Safe torque off (STO) acc. to EN/IEC61800-5-2: IEC61508 ed2: SIL 3, IEC 61511: SIL 3, IEC 62061: SIL CL 3, EN ISO 13849-1: PL e
Optional safety features	ACS880	Safe stop 1 (SS1), safely-limited speed (SLS), safe stop, emergency (SSE), safe brake control (SBC), safe maximum speed (SMS), prevention of unexpected startup (POUS), safe direction (SD) and safe speed monitor (SSM) acc. To EN/IEC61800-5-2: IEC61508 ed2: SIL 3, IEC 61511: SIL 3, IEC 62061: SIL CL 3, EN ISO 13849-1: PL e
Optional safety fieldbus	ACS880	PROFIsafe over PROFINET, certified

Environmental limits		
Ambient temperature		
Transportation and storage		-40 to +70 °C (-40 to +158 °F)
Operation	ACS380	-10 to +50 °C (14 to 122 °F), up to +60 °C (140 °F) with derating
	ACS880	-10 to +40 °C (14 to 122 °F), up to +55 °C (131 °F) with derating No frost allowed
Cooling method		Air-cooled, dry clean air
Altitude		0 to 4000, (0 to 13000 ft), derating above 1000m (3300 ft)
Relative humidity		5 to 95%, no condensation allowed
Degree of protection		IP20 as standard
Contamination levels		No conductive dust allowed
Storage		IEC 60721-3-1, Class 1C2 (chemical gases)
		Class 1S2 (solid particles)
Transportation		IEC 60721-3-2, Class 2C2 (chemical gases)
		Class 2S2 (solid particles)
Operation		IEC 60721-3-3, Class 3C2 (chemical gases)
		Class 3S2 (solid particles)

Product compliance		
CE		
Low Voltage Directive 2006/95/EC, EN 61800-5-1: 2007		
Machinery Directive 2006/42/EC, EN 61800-5-2: 2007		
EMC Directive 2004/108/EC, EN 61800-3: 2004 + A1: 2012		
UL, cUL certification pending		
ITÜV certification for functional safety pending		
Quality assurance system ISO 9001		
Environmental system ISO 14001		
Waste electrical and electronic equipment directive (WEEE) 2002/96/EC		
RoHS directive 2011/65/EU		
EAC		

How to select a drive

It is very easy to select the right drive. This is how you build up your own ordering code using the type designation key.

1 Start with identifying your supply voltage
This tells you what rating table to use. See pages 15 or 17.

2 Choose your motor's power and current rating
from the ratings table on page 15 or 17.

P_{rated} kW	I_{rated} A
0.25	1.8
0.37	2.4
0.55	3.7
0.75	4.8
1.1	6.9
1.5	7.8
2.2	9.8

3 Select your drive's ordering code
Select the ordering code for the ACS880 machinery drive (page 17) from the rating table based on your motor's nominal power rating.

Type designation
ACS880-M04-03A0-2
ACS880-M04-03A6-2
ACS880-M04-04A8-2
ACS880-M04-06A0-2
ACS880-M04-08A0-2
ACS880-M04-010A-2
ACS880-M04-014A-2
ACS880-M04-018A-2
ACS880-M04-025A-2
ACS880-M04-030A-2
ACS880-M04-044A-2
ACS880-M04-044A-2
ACS880-M04-050A-2
ACS880-M04-061A-2
ACS880-M04-078A-2
ACS880-M04-061A-5

Select the ordering code for the ACS380 machinery drive by choosing either the standard or the configured variant. Then choose the desired EMC level on page 15.

If the configured variant is selected, choose your fieldbus protocol (page 15) by selecting the correct option code and add the option codes to drive's ordering code.

Type designation
ACS380-04xx02A4-1
ACS380-04xx03A7-1
ACS380-04xx04A8-1
ACS380-04xx06A9-1
ACS380-04xx07A8-1
ACS380-04xx09A8-1
ACS380-04xx12A2-1

Connectivity types	
ACS380-04xS	Standard variant
ACS380-04xC	Configured variant

EMC filterin=vel	
ACS380-040x	EMC category C3 (400 V) or C4 (230 V)
ACS380-042x	EMC category C2

4 Choose your options Add the option codes (pages 23, 24, 25, 26, 29 and 31) to the drive's ordering code. Remember to use a "+" mark before each option code.

Option code	Description	Type designation
3AA0000008311	Assistant control panel	ACS-AP-1
3AA0000008365	Assistant control panel with Bluetooth interface	ACS-AP-W
3AA0000008368	Basic control panel	ACS-BP-S
3AA0000108378	Control panel mounting platform (flush mounted, requires also panel bus adapter on the drive)	DRMP-01
3AA0000008374	Control panel mounting platform (surface mounted, requires also panel bus adapter on the drive)	DRMP-02

Type designation:

Product series

Types and construction

Rating

Voltage

Option code

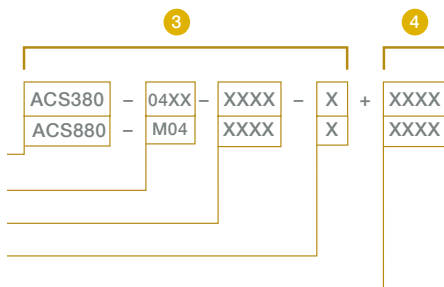

Persistent predictability with ACS380 machinery drives

Built on ABB's common drives architecture, the ACS380 drive module is ideal for machine building that requires motor technologies with powers from 0.25 to 7.5 kW and voltages from 200 to 480 V. With enclosure class IP20 as standard, these modular drives are easy to place inside cabinets for use in industries such as food and beverage, material handling and textile. Typical constant torque applications include mixers, conveyors, cranes and other constant-torque applications in machine building.

Easy to install and use

The compact ACS380 comes in different frame sizes (R0 to R3) and several variants (for both EMC and connectivity use) providing easy installation and commissioning. The drive is remarkably easy to integrate into machine designs as the configured variant of the drive has pre-configured fieldbus protocols (EtherCAT®, PROFIBUS, PROFINET, CANopen®). The standard variant of the drive comes with extensive I/O and built-in Modbus RTU protocol.

The ACS380 controls a broad range of motors. The drive offers a built-in icon based interface that makes adjusting the drive settings fast and easy. Optional control panels include the basic control panel and the assistant control panel with and without a bluetooth connection. Adaptive programming provides additional flexibility for different machine requirements, meeting the demands of exact machine design. The ACS380 offers integrated safety with safe torque off (STO) built-in as standard. Feedback from the motor is also available as an option. The drive is designed for optimal cooling with thermal management up to 50 °C ambient temperatures, without derating.



The built-in icon based control panel interface for easy commissioning and configuration

ACS380 ratings, types and voltages

$U_N = 200\text{ V}$ (range 200 to 240 V). The power ratings are valid at nominal voltage 200 V (0.25 to 3.0 kW)

Heavy-duty use		Maximum output current	Light-overload use		Nominal ratings		Type designation	Frame size
P_{Hd} kW	I_{Hd} A	I_{max} A	P_{Ld} kW	I_{Ld} A	P_N kW	I_N A		
0.25	1.8	3.2	0.37	2.3	0.37	2.4	ACS380-04xx-02A4-1	R0
0.37	2.4	4.3	0.55	3.5	0.55	3.7	ACS380-04xx-03A7-1	R0
0.55	3.7	6.7	0.75	4.6	0.75	4.8	ACS380-04xx-04A8-1	R1
0.75	4.8	8.6	1.1	6.6	1.1	6.9	ACS380-04xx-06A9-1	R1
1.1	6.9	12.4	1.5	7.4	1.5	7.8	ACS380-04xx-07A8-1	R1
1.5	7.8	14.0	2.2	9.3	2.2	9.8	ACS380-04xx-09A8-1	R2
2.2	9.8	17.6	3.0	11.6	3.0	12.2	ACS380-04xx-12A2-1	R2

$U_N = 400\text{ V}$ (range 380 to 480 V). The power ratings are valid at nominal voltage 400 V (0.37 to 11 kW)

Heavy-duty use		Maximum output current	Light-overload use		Nominal ratings		Type designation	Frame size
P_{Hd} kW	I_{Hd} A	I_{max} A	P_{Ld} kW	I_{Ld} A	P_N kW	I_N A		
0.37	1.2	2.2	0.55	1.7	0.55	1.8	ACS380-04xx-01A8-4	R0
0.55	1.8	3.2	0.75	2.5	0.75	2.6	ACS380-04xx-02A6-4	R1
0.75	2.6	4.7	1.1	3.1	1.1	3.3	ACS380-04xx-03A3-4	R1
1.1	3.3	5.9	1.5	3.8	1.5	4	ACS380-04xx-04A0-4	R1
1.5	4	7.2	2.2	5.3	2.2	5.6	ACS380-04xx-05A6-4	R1
2.2	5.6	10.1	3	6.8	3	7.2	ACS380-04xx-07A2-4	R1
3	7.2	13	4	8.9	4	9.4	ACS380-04xx-09A4-4	R1
4	9.4	16.9	5.5	12	5.5	12.6	ACS380-04xx-12A6-4	R2
5.5	12.6	22.7	7.5	16.2	7.5	17	ACS380-04xx-17A0-4	R3
7.5	17	30.6	11	23.8	11	25	ACS380-04xx-25A0-4	R3

Dimensions

Frames IP20	Height	Width	Depth	Weight
	mm	mm	mm	kg
R0	220	70	174	1.4
R1	220	70	174	1.6
R2	220	95	174	1.9
R3	220	169	174	tba

Ordering variants

Connectivity type	
ACS380-04xS	I/O and Modbus -variant
ACS380-04xC	Configured variant
ACS380-04xC-xxxx-x+K454	PROFIBUS DP protocol configured
ACS380-04xC-xxxx-x+K457	CANopen® protocol configured
ACS380-04xC-xxxx-x+K469	EtherCAT® protocol configured
ACS380-04xC-xxxx-x+K475	Profinet I/O protocol configured. Ethernet/IP™ and Modbus TCP also built-in.
EMC filtering level	
ACS380-040x	EMC category C3 (400 V) or C4 (230 V)
ACS380-042x	EMC category C2

Nominal ratings	
I_N	Rated current available continuously without overloadability at 50 °C.
P_N	Typical motor power in no-overload use.
Maximum output current	
I_{max}	Maximum output current. Available for 2 seconds at start, then as long as allowed by drive temperature.
Heavy-duty use	
I_{Hd}	Continuous current allowing 150% I_{Ld} for 1 minute every 10 minutes at 50 °C.
P_{Hd}	Typical motor power in heavy-duty use.
Light-overload use	
I_{Ld}	Continuous current allowing 110% I_{Ld} for 1 minute every 10 minutes at 50 °C.
P_{Ld}	Typical motor power in light-overload use.

The ratings apply at 50 °C ambient temperatures.

For derating at higher altitudes, temperatures or switching frequencies, see the user's HW manual, document code: 3AXD50000029274

Adaptable performance with ACS880 machinery drives

Built on ABB's common drives architecture, the ACS880 machinery drive module is a versatile and high-level drive that is easy to adapt to demanding machine building needs. With enclosure class IP20 as standard, the drive is designed to control virtually any type of motor accurately and dependably in a power and voltage range from 0.37 to 45 kW and 230 to 500 V. The voltage range can be extended utilizing ABB's industrial drives. ACS880 machinery drives fit optimally inside cabinets used in various industries including food and beverage, material handling and material forming. ABB's premium motor control technology direct torque control (DTC) is built-in as standard for precise control of applications such as winders, wire drawing, mixers, cranes, sorting conveyors and other high-performance applications within machine building.

Full package for machine building

The ACS880 machinery drive comes in four different frame sizes (R1 to R4) with three option slots for adaptable installation and commissioning. The ACS880 machinery drive offers IEC 61131-3 programming capabilities for flexible control logic design and integration into automation systems. The drive offers integrated safety functionality with safe torque off (STO) built-in as standard, and the optional plug-in safety functions module (FSO-12/-21) for enhanced application safety.

The drive can be quickly and reliably connected to a safety PLC through PROFIsafe over PROFINET. Other options include applications control programs for winder, cranes and high speed applications. The drive also supports a wide range of fieldbus protocols, EMC filters, encoder and resolver interfaces, chokes and brake resistors. The drive is equipped with general motion features, which enable synchronized positioning tasks. The ACS880 machinery drive comes with energy efficiency calculators and the Drive composer PC tool for easy commissioning and configuration. Other compatible tools for adaptable performance include the Automation Builder, Drive Customizer and the Functional safety design tool (FSDT-01).



Integrated safety features include safe torque off (STO) as standard, the plug in safety functions module and PROFIsafe over PROFINET connectivity to PLC.

ACS880 ratings, types and voltages

$U_N = 200\text{ V}$ (range 200 V to 240 V). The power ratings are valid at nominal voltage 230 V (0.37 to 22 kW)

Heavy-duty use		Maximum output current	Light-overload use		Nominal ratings		Type designation	Frame size
P_{Hd} kW	I_{Hd} A		I_{max} A	P_{Ld} kW	I_{Ld} A	P_N kW		
0.37	2.5	4.4	0.37	2.8	0.37	3	ACS880-M04-03A0-2	R1
0.37	3	5.3	0.55	3.4	0.55	3.6	ACS880-M04-03A6-2	R1
0.55	4	7.0	0.75	4.5	0.75	4.8	ACS880-M04-04A8-2	R1
0.75	5	8.8	1.1	5.5	1.1	6	ACS880-M04-06A0-2	R1
1.1	6	10.5	1.5	7.6	1.5	8	ACS880-M04-08A0-2	R1
1.5	9	13.5	2.2	9.7	2.2	10.5	ACS880-M04-010A-2	R2
2.2	11	16.5	3	13	3	14	ACS880-M04-014A-2	R2
3	14	21	4	16.8	4	18	ACS880-M04-018A-2	R2
4	19	33	5.5	23	5.5	25	ACS880-M04-025A-2	R3
5.5	24	36	7.5	28	7.5	30	ACS880-M04-030A-2	R3
7.5	29	44	7.5	32	7.5	35	ACS880-M04-035A-2	R3
7.5	35	53	11	41	11	44	ACS880-M04-044A-2	R3
11	44	66	11	46	11	50	ACS880-M04-050A-2	R3
11	52	78	15	57	15	61	ACS880-M04-061A-2	R4
15	66	100	18.5	74	18.5	78	ACS880-M04-078A-2	R4

$U_N = 500\text{ V}$ (range 380 to 500 V). The power ratings are valid at nominal voltage 400 V (0.75 to 45 kW)

Heavy-duty use		Maximum output current	Light-overload use		Nominal ratings		Type designation	Frame size
P_{Hd} kW	I_{Hd} A		I_{max} A	P_{Ld} kW	I_{Ld} A	No-overload use		
P_{Hd} kW	I_{Hd} A	I_{max} A	P_{Ld} kW	I_{Ld} A	P_N kW	I_N A		
0.75	2.5	4.4	1.1	2.8	1.1	3	ACS880-M04-03A0-5	R1
1.1	3	5.3	1.5	3.4	1.5	3.6	ACS880-M04-03A6-5	R1
1.5	4	7.0	1.5	4.5	2.2	4.8	ACS880-M04-04A8-5	R1
2.2	5	8.8	2.2	5.5	2.2	6	ACS880-M04-06A0-5	R1
2.2	6	10.5	3	7.6	3	8	ACS880-M04-08A0-5	R1
4	9	13.5	4	9.7	4	10.5	ACS880-M04-010A-5	R2
5.5	11	16.5	5.5	13	5.5	14	ACS880-M04-014A-5	R2
7.5	14	21	7.5	16.8	7.5	18	ACS880-M04-018A-5	R2
7.5	19	33	11	23	11	25	ACS880-M04-025A-5	R3
11	24	36	15	28	15	30	ACS880-M04-030A-5	R3
15	29	44	15	32	18.5	35	ACS880-M04-035A-5	R3
18.5	35	53	22	41	22	44	ACS880-M04-044A-5	R3
22	44	66	22	46	22	50	ACS880-M04-050A-5	R3
22	52	78	30	57	30	61	ACS880-M04-061A-5	R4
37	66	100	37	74	37	78	ACS880-M04-078A-5	R4
37	75	124	45	90	45	94	ACS880-M04-094A-5	R4

ACS880 ratings, types and voltages

Frames IP20	Height mm	Width mm	Depth 1 mm	Depth 2 mm	Weight kg
R1	474	93.5	197	205	3.4
R2	476	101	275	280	5.6
R3	658	166	276	282	15.8
R4	744	221	276	282	21.5

Nominal ratings

I_N Rated current available continuously without overloadability at 40 °C.

P_N Typical motor power in no-overload use.

Maximum output current

I_{max} Maximum output current. Available for 2 seconds at start, then as long as allowed by drive temperature.

Heavy-duty use

I_{Hd} Continuous current allowing 150% I_{Ld} for 1 minute every 10 minutes at 40 °C.

P_{Hd} Typical motor power in heavy-duty use.

Light-overload use

I_{Ld} Continuous current allowing 110% I_{Ld} for 1 minute every 10 minutes at 40 °C.

P_{Ld} Typical motor power in light-overload use.

The ratings apply at 40 °C ambient temperatures: The ratings apply for the frames R1 to R4 up to 40 °C.
For derating at higher altitudes, temperatures or switching frequencies, see the user's HW manual.

Connectivity and flexibility to meet your needs



When designing a machine, all necessary devices have to be compatible with each other to form a high-performing system level solution. Devices such as drives, programmable logic controllers (PLCs), motors, Human machine interfaces (HMIs), fieldbuses, safety functions and certified connectivity need to be integrated seamlessly into one common system and to provide reliability, cost efficiency and flexibility for the entire design process.

All-compatible machinery drives

ABB's machinery drives have hundreds of hours of testing behind them. They are certified, meeting high required standards. They connect smoothly to PLC's through a wide range of available fieldbus protocols, enabling fast and secure communication between them. In order to control virtually any type of motor ABB's machinery drives do this optimally and safely, saving energy and the environment at the same time. In order to access several drives and motors via the PLC there are various types of human machine interfaces such as drive control panels and touchscreen displays for fast and easy configuration. Safety functionality can be designed around or plugged into the drives and connected smoothly to a safety PLC.

Certified solution

ABB machinery drives form with other automation devices a reliable and certified alliance that saves time and costs for the machine builder. Still, as everything is compatible, there must be flexibility to optimize the functionality of the machine. ABB also offers support and maintenance services for throughout the life cycle of the drives in the machine.

Standard software with versatile features

Commissioning easier than ever before

The assistant control panel for the ACS880 machinery drive has a clear and intuitive user interface as well as different assistants to make the drive easy to set up and use. This saves on commissioning and learning time. The icon based control panel of the ACS380 is intuitive and easy to use for basic operation, settings and fault tracking.

Optimized motor control

The machinery drives offer sophisticated process control in scalar, vector and DTC control modes. The drive supports a wide range of motors including induction and permanent magnet motors. Many embedded protection and other features improve performance of the motor and process.

Flying start

Flying start is available for scalar, vector and DTC control modes. Catching a running motor, enabled by the flying start feature, is often required in applications with long freewheeling times.

Load profile

The load profile feature collects drive values to a log such as current. The log shows how the drive is operating and enables you to analyze and optimize the application.

Reduced motor noise

The drive reduces motor noise by spreading the switching frequencies over a user-specified range. The user can define an allowed range of used switching frequency. As a result, the drive maximizes the actual used switching frequency based on thermal measurement. The higher used switching frequency reduces motor noise at low load without limiting full current at maximum load.

Optimized energy use

The machinery drives come with features that help you save and manage energy. The energy optimizer feature operates scalar, vector and DTC control modes, ensuring maximum torque per ampere and reducing energy drawn from the supply. You can monitor the hourly, daily and cumulative energy consumption via kWh counters. When the drive replaces other control methods (eg, direct-online control), you can follow the saved energy, CO₂ emissions or money, and see how fast the drive brings you a return on investment.

Easy diagnostics for trouble-free operation

The control panel's diagnostics menu enables you to effectively analyze and resolve issues regarding why the drive is performing as it is - running, stopped or running at the present speed. Active faults, warnings and event logs are shown in the menu. The menu shows if there are any active limitations to the drive operation and gives instructions on how to resolve them. The Drive composer PC tool offers more detailed diagnosis and signal monitoring. The entry level PC tool is available for free via the ABB website (www.abb.com).

Adapt the drive and machine to run optimally

Adaptive programming offers an easy alternative for simple programming needs. It is embedded inside the software of the drive and is especially handy when there is a need to distribute some of the machine's control logic to the drive. Adaptive programming brings savings when the drive is adjusted to control the application optimally. The Drive composer pro PC tool is used for setting up adaptive programming.



Drive application programming based on IEC standard 61131-3 for ACS880 machinery drives

Automation Builder, ABB's software suite for automation engineering, makes programming of industry devices such as drives, PLC's, robots and HMI's easy using one Integrated engineering suite. The Automation Builder is used both for engineering individual industry devices and for putting together entire automation solutions. It is based on a widely used software environment that fulfills many different requirements of industrial automation projects, according to the IEC standard 61131-3. As a single tool, the Automation Builder reduces time typically needed for system configuration and programming. It also reduces the need for installing and maintaining separate programs simultaneously. Automation Builder enables the possibility to do online diagnostic checking of multiple tasks performed by different industrial devices such as ACS880 machinery drives.

Drive application programming

Automation Builder makes it possible for system integrators and machine builders to integrate their desired functionality and know-how directly into the ACS880 machinery drive. This is possible as the drive comes with programming capability embedded inside the drive. Designing an application program in the drive makes the end user application run more efficiently, even without a separate programmable controller. It also brings higher end-product quality and requires less need for installation space and wiring.

Automation Builder lets you extend the standard functionality of parameter functions for the ACS880 machinery drive. This makes the drive very flexible to meet exact requirements set for end user applications. The library management functionality in Automation Builder shortens engineering time as reuse of existing program code is possible. Additional features include the ability to select and use one of five different programming languages, effective program debugging and user password protection.

Integrated engineering suite for operating several industry components together

Using the Drive manager tool embedded in Automation Builder together with ABB's AC500 PLC product family gives the user online connection to all drives in a fieldbus network. This speeds up commissioning and makes diagnostic of the entire automation system easy. Automation Builder saves all the configuration data of industry devices, including drive parameter settings, and program code to the same project archive. This makes engineering work more consistent and manageable.

The drive application programming license is ordered together with the drive.

Drive application programmability for ACS880

Option	Option code
License key ¹⁾	+N8010
Automation Builder Standard Single, DM-TOOL ²⁾	1SAP193000R0101
Automation Builder Premium Single, DM-PREEM ²⁾	1SAP193005R0101

¹⁾ The Automation Builder tools must be ordered separately.

For further information please contact your local ABB.

²⁾ Single user license - bound to PC or DM-KEY (USB Key)



Automation Builder



CP600



AC500



ACS880



IRB 7600

Application control programs for ACS880 machinery drives

Our application control programs have been developed for the ACS880 machinery drives by working closely with our customers over many years. This has resulted in application programs that include the lessons learned from many customers, and that are designed to give you the flexibility to adapt the programs to your specific needs. These programs enhance application usability and lower energy consumption. They increase safe operation of the applications and reduce the need for a PLC. Other benefits include protection of machinery and optimization of application productivity. The programs also optimize time usage and lower operational costs.

The ACS880 machinery drive application control programs come with adaptive programming features. This makes fine tuning of the ready-made application control program functionalities easy. Additionally, we understand that you may need to use different configurations in your process. That's why each of our control programs comes with the ability to configure up to four different configurations. The ACS880 offers integrated safety with safe torque off (STO) functionality as standard. The optional safety functions module comes with several safety functions including safe brake control (SBC).





Control program for winder

This control program makes sure that the unwinding and winding of a roll of web material, such as textile, plastic and paper is performed optimally. The control program observes the diameter of rolls and tension of the web material and makes sure that the drives controlling different parts of the winder are in sync. Based on the feedback from the dancer or tension measurement of the web, the speed or torque of the drive is adjusted appropriately. The result is a straightforward, cost-effective solution in web handling. Another feature is the mechanics ID run function that calculates automatically the inertia and friction of the roll. This speeds up the commissioning of the drive.

Option code

+N5000

Control program for cranes

This control program makes it possible to control crane movements in hoist, trolley and travel motion using the same software. The control program comes with integrated mechanical brake control to assure safe opening and closing of the mechanical disc or drum brakes. Stand-alone and master-follower functionality is supported along with synchro control of multimotors. The synchro control for common operation of the load functionality makes it possible to lift and lower loads, such as containers, in a smooth and balanced way during transportation. The load speed control function maximizes the hoist speed for the given load and ensures that there is sufficient motor torque in the field weakening area. This minimizes operation time and optimizes crane capacity. Fieldbus and conventional I/O control are supported. The anti-sway function is designed for indoor cranes to prevent unnecessary swaying of the load.

Option code

+N5050

Control program for high-speed applications

This control program is designed for applications that require higher output speeds than 500 Hz. The program is typically used with spindle or woodworking machinery. It is especially suitable for permanent magnet high-speed motors. The program requires export licence when delivered outside the EU. The high-speed software is handled according to EC regulation N.o 428/2009 appendix I as it is stated in the European Commission's delegated act (EU) N:o 1382/2014, item 3A225.

For further ordering information please contact your local ABB.

PC tool for drive monitoring and process tuning capabilities

The Drive composer PC tool offers fast and harmonized setup, commissioning and monitoring for the whole all-compatible drives portfolio. The free version of the tool provides startup and maintenance capabilities, while the professional version provides additional features such as custom parameter windows, control diagrams of the drive's configuration and improved monitoring and diagnostics.

The Drive composer tool is connected to the drive using the mini USB connection on the assistant control panel. All drive information such as parameter loggers, faults, backups and event lists are gathered into a support diagnostics file with a single mouse click. This provides faster fault tracking, shortens downtime and reduces operational and maintenance costs.

Drive composer pro offers extended functionality

Drive composer pro provides the same standard functionality as the free version and some additional features, like graphical control diagrams. The control diagrams save users from browsing long lists of parameters and help to set the drive's logic quickly and easily. The tool has fast monitoring capabilities of multiple signals from several drives in the panel bus. Full backup and restore functions are also included.



Remote monitoring access worldwide

The remote monitoring tool, NETA-21, gives easy access to the drive via the Internet or local Ethernet network. NETA-21 comes with a built-in web server. Compatible with standard web browsers, it ensures easy access to a web-based user interface. Through the web interface, the user can configure drive parameters, monitor drive log data, load levels, run time, energy consumption, I/O data and bearing temperatures of the motor connected to the drive.

Remote monitoring option

Ordering code	Description	Type designation
3AUA0000094517	2 x panel bus interface, 2 x 32 = max. 64 drives 2 x Ethernet interface SD memory card USB port for WLAN/3G	NETA-21



Drive commissioning and adaptable use with your control panel

Almost anyone can set up and commission the machinery drive using available control panels. Both machinery drives use the assistant control panel (AP-I, AP-S or AP-W). The ACS380 comes with the integrated icon based control panel as standard. You do not need to know any drive parameters as the control panel helps you to set up the essential settings quickly and get the drive into action.

Easy drive setup

- The assistant control panel offers a settings menu with embedded assistants providing a smart and quick way to set up the drive.
- The integrated icon based control panel in the ACS380 makes drive setup fast and easy.
- Each setting for both control panels is clearly named or shown with an icon by its function, such as motor, ramp or limit settings.

Simplified process monitoring

- One glance at the assistant control panel's editable display will show the status of the drive and its processes.
- See how the electrical terminals are configured, what is the actual status and get a quick access to the related settings from the I/O menu.
- Add information eg, to I/O signals, customize fault and warning messages or give the drive a unique name with the assistant control panel's text editor.
- Connect the PC tool to the drive through the USB connector on the assistant control panel.

Simplified drive maintenance

- Faults or warnings are quickly resolved as the help in provides context sensitive guidance and troubleshooting instructions.
- Powerful assistant manual and automatic backup and restore functions (with name, date and content).

Control panel options

All panels excluding the ACS-AP-S are optional for the ACS880 machinery drive. The integrated icon based control panel comes as standard in the ACS380. Other panels are available as options.



Ordering code	Description	Type designation
3AUA0000088311	Assistant control panel	ACS-AP-I
3AUA0000064884	Assistant control panel	ACS-AP-S ¹⁾
3AXD0000025965	Assistant control panel with bluetooth interface	ACS-AP-W
3AXD0000028828	Basic control panel	ACS-BP-S
3AUA0000108878	Control panel mounting platform (flush mounted)	DPMP-01
3AXD0000009374	Control panel mounting platform (surface mounted)	DPMP-02

¹⁾ Not available for ACS880 machinery drives.

Flexible connectivity to automation networks

A fieldbus enables communication between drives and PLC systems, I/O devices and the process. Fieldbus communication reduces wiring costs when compared with traditional hard wired input/output connections. Fieldbus systems also offer the ability to gather large amounts of data, which can then be utilized for improving the performance or safety of the machine.

The machinery drives are compatible with a wide range of fieldbus protocols. ACS880 machinery drives comes with Modbus RTU fieldbus interface as standard. The optional fieldbus adapter can be easily be mounted on the drive. In ACS380 the standard variant of the drive comes with built-in Modbus RTU protocol. In configured variant the wanted fieldbus protocol is selected by option code.

Drive monitoring

A set of drive parameters and/or actual signals, such as torque, speed, current, etc., can be selected for cyclic data transfer, providing fast data access.

Drive diagnostics

Accurate and reliable diagnostic information can be obtained through the alarm, limit and fault words, giving easy interfacing with plantwide HMIs.

Cabling

Substituting the large amount of conventional drive control cabling and wiring with a single cable reduces costs and increases system reliability and flexibility.

Design

The use of fieldbus control reduces engineering time at installation due to the modular structure of the hardware and software and the simplicity of the connections to the drives.

Commissioning and assembly

The modular machine configuration allows precommissioning of single machine sections and provides easy and fast assembly of the complete installation.

Universal communication with ABB fieldbus adapters

The machinery drives support the following fieldbus protocols:

Option code	Fieldbus protocol	Adapter
+K454	PROFIBUS DP, DPV0/DPV1	FPBA-01-M
+K457	CANopen®	FCAN-01-M
+K469	EtherCAT®	FECA-01-M
+K475	Two port EtherNet/IP™, Modbus TCP, PROFINET IO	FENA-21-M
+K473	EtherNet/IP™, Modbus TCP, PROFINET IO	FENA-11
+K458	Modbus RTU	FSCA-01
+K451	DeviceNet™	FDNA-01
+K462	ControlNet	FCNA-01
+K470	PowerLink	FEPL-02



Standard interface and extensions for ACS380 machinery drives

The ACS380 machinery drives offer two different standard interfaces: the standard variant (I/O and Modbus) and the configured variant with different interfaces. In addition the drive has one option slot available that can be used for speed feedback, relay extension or option which allow external +24 V supply. For further information please see the ACS380 hardware and firmware manuals.



Default I/O connections of standard variant

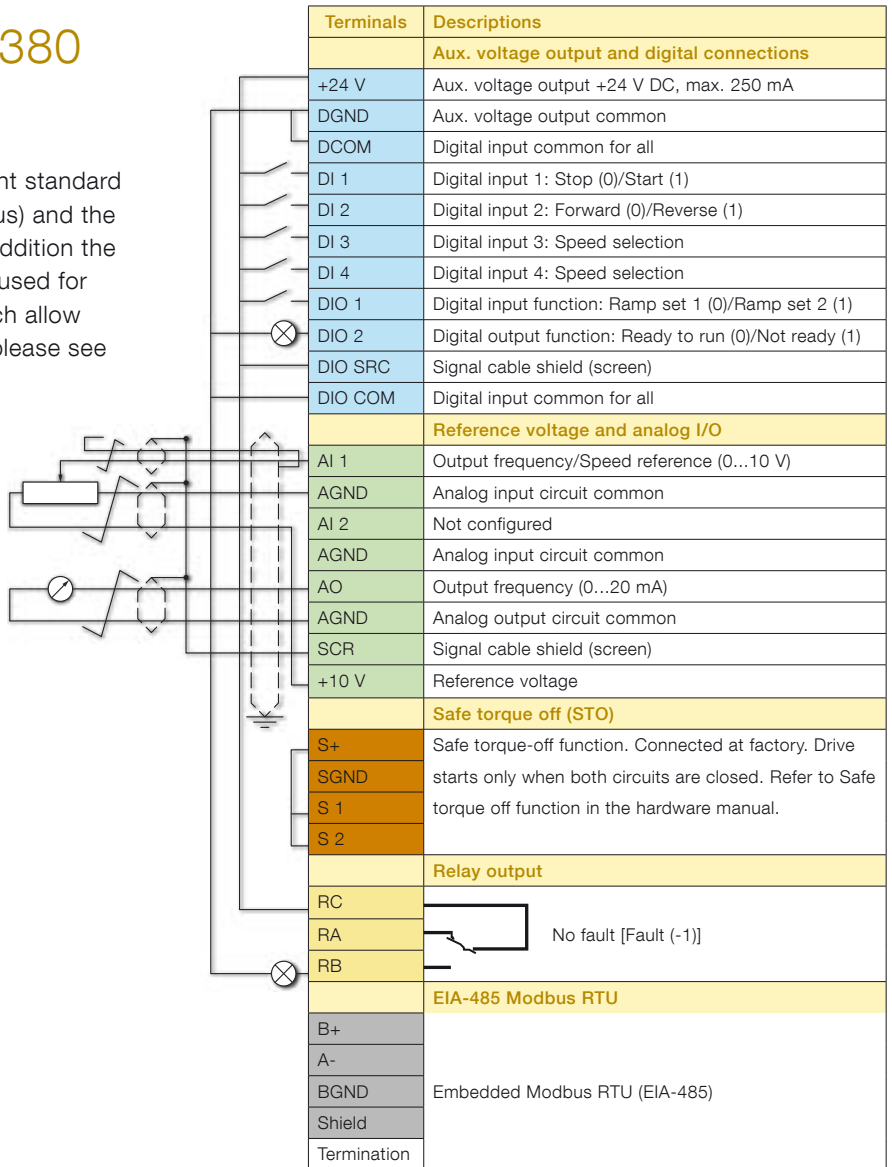

Default connections of configured variant

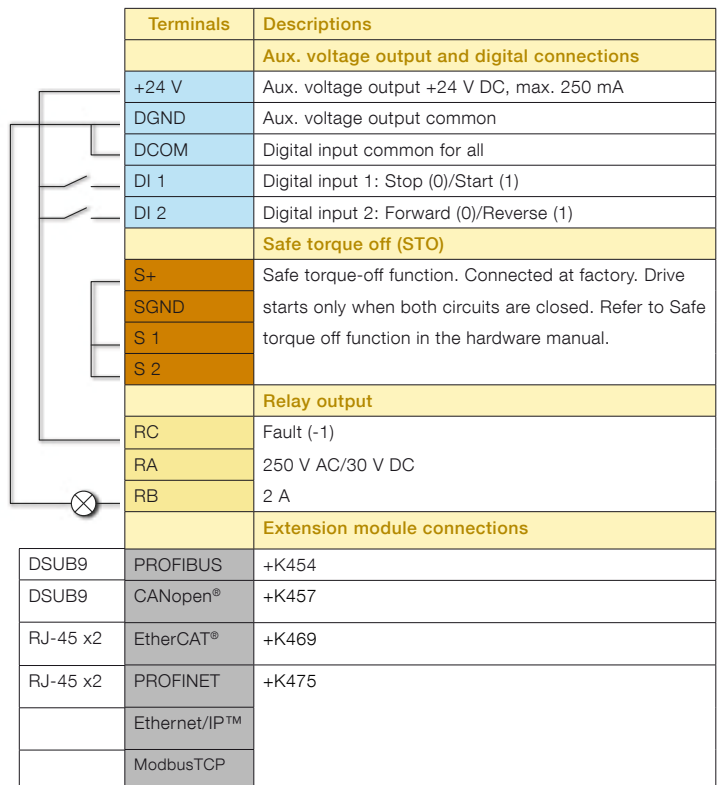

Standard interface and extensions for ACS880 machinery drives

The ACS880 machinery drives offer a wide range of standard interfaces. The drive has three option slots that can be used for extensions including fieldbus adapters and input/output extension modules that allow external +24 V supply with the frames R1 to R4. For further information, please see the ACS880 user manuals.



Input/output connection diagram

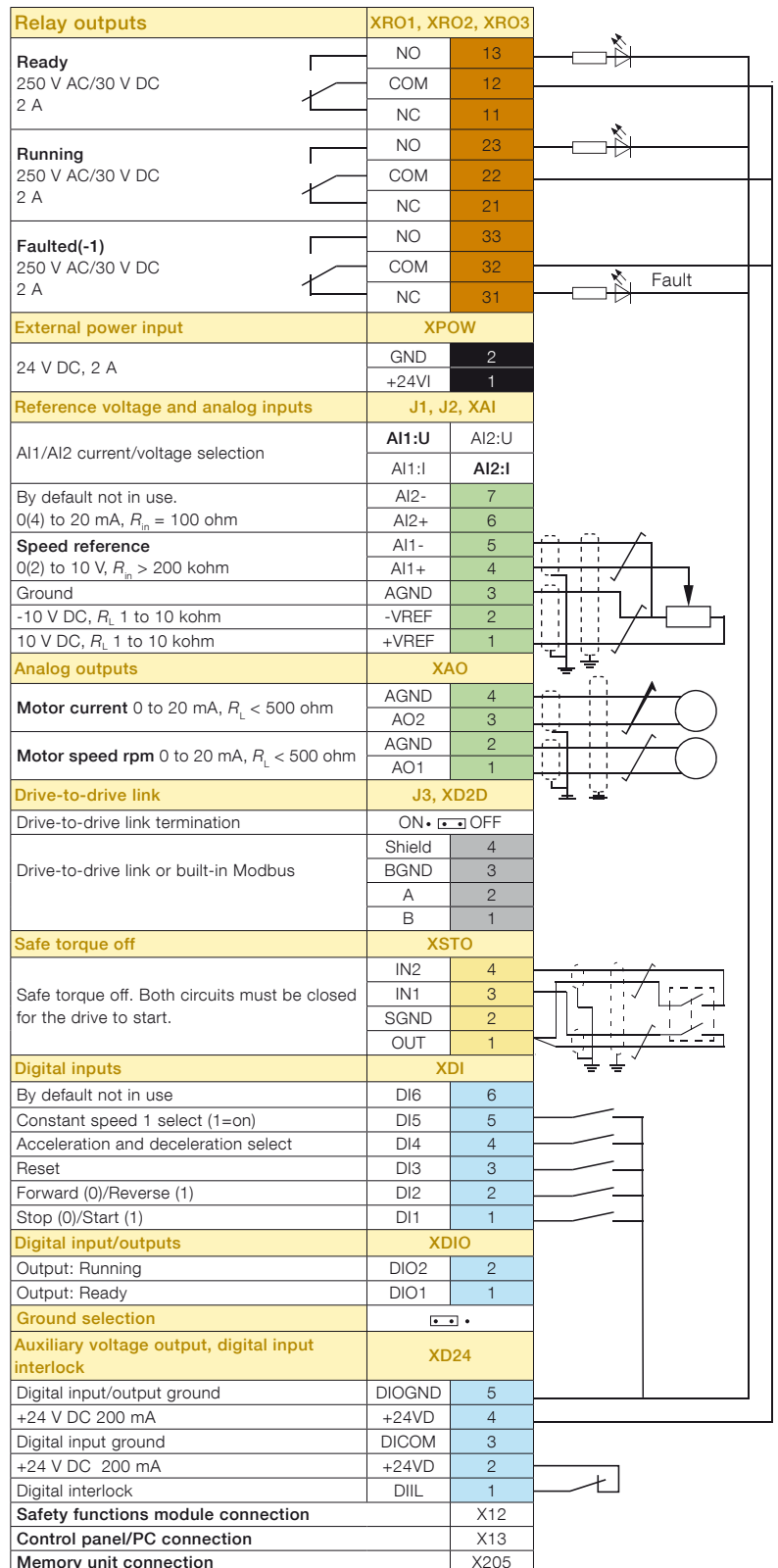

Input/output, extension and feedback modules for increased connectivity

Standard input and output of machinery drives can be extended by using optional analog and digital input/output extension modules. The modules are easily installed in the extension slots located in the drive. The machinery drives can also be connected to feedback modules.

The machinery drives can be connected to various feedback devices, such as HTL pulse encoder, TTL pulse encoder, absolute encoder and resolver. The optional feedback module is installed in the option slot on the drive. It is possible to use two feedback modules at the same time, either of the same or different type.



I/O module options

Option code	Description	Type designation
+L501	Digital extension: 4x DIO, 2x RO	FIO-01 ¹⁾
+L500	Analog extension: 3x AI (mA/V), 1x AO (mA), 2x DIO	FIO-11 ¹⁾

Extension module options

Option code	Description	Type designation
+L534	External 24 V DC	BAPO-01 ²⁾
+L511	External relay option (4xRO)	BREL-01 ²⁾

Feedback interface module options

Option code	Connections	Option
+L517	2 inputs (TTL pulse encoder), 1 output	FEN-01 ¹⁾
+L518	2 inputs (SinCos absolute, TTL pulse encoder), 1 output	FEN-11 ¹⁾
+L516	2 inputs (Resolver, TTL pulse encoder), 1 output	FEN-21 ¹⁾
+L502	1 input (HTL pulse encoder), 1 output	FEN-31 ¹⁾
+L535	Encoder interface + External 24 V DC	BTAC-02 ²⁾

¹⁾ only with ACS880-M04

²⁾ only with ACS380

Integrated safety reduces costs for ACS880 machinery drives



Integrated safety reduces the need for external safety components, simplifying configuration and reducing installation space. Safety functionality is a built-in feature in the machinery drives with safe torque off (STO) as standard. For ACS880 machinery drives, additional safety functions can be commissioned with the optional and compact safety functions module. The drives' functional safety is designed in accordance with EN/IEC 61800-5-2 and complies with the requirements of the European Union Machinery Directive 2006/42/EC.

Safe torque off as standard

Safe torque off (STO) is used to prevent unexpected startup and in stopping-related functions, enabling safe machine maintenance and operation. With safe torque off activated, the drive will not provide a rotational field. This prevents the motor from generating torque on the shaft. This function corresponds to an uncontrolled stop in accordance with stop category 0 of EN 60204-1.

The safety functions module

The ACS880 machinery drive offers the easy to connect and configure safety functions module (FSO-12 and -21) with a wide range of safety functions and a self-diagnostic function that meets current safety requirements and standards, all in one compact module. Compared to using external safety components, the safety functions module comes with the supported functions seamlessly integrated with the drive functionality, reducing the implementation of safety function connections and configuration. Installation of the module results in less need for cabling and provides a cost-effective solution.

Commissioning and configuration of the safety functions module is done with the Drive composer pro PC tool. For ACS880 machinery drives this makes it possible to build larger safety systems using PROFIsafe over Profinet connection between a safety PLC (such as AC500-S) and the ACS880 machinery drive. The connection is achieved using the FENA-21 fieldbus adapter module and the safety functions module.

The safety functions module can also be ordered as a spare part kit and installed afterwards to the drive. The kit includes the most common assembly accessories for ACS880 machinery drives.

The module supports the following safety functions which achieve up to SIL 3 or PL e (Cat. 3) safety level:

- **Safe stop 1 (SS1)** brings the machine to a stop (STO) using a monitored deceleration ramp. It is typically used in applications where the machinery motion needs to be brought to a stop (stop category 1) in a controlled way before switching over to the no-torque state.
- **Safe stop emergency (SSE)** can be configured to, upon request, either activate STO instantly (category 0 stop), or first initiate motor deceleration and then, once the motor has stopped, activate the STO (category 1 stop).
- **Safe brake control (SBC)** provides a safe output for controlling the motor's external (mechanical) brakes, together with STO.
- **Safely-limited speed (SLS)** ensures that the specified speed limit of the motor is not exceeded. This allows machine interaction to be performed at slow speed without stopping the drive. The safety function module comes with four individual SLS settings for speed monitoring.
- **Safe maximum speed (SMS)** monitors that the speed of the motor does not exceed the configured speed limit.
- **Prevention of unexpected startup (POUS)** ensures that the machine remains stopped when people are in a dangerous area.
- **Safe direction (SDI)** ensures that rotation is allowed only to the selected direction. Available only with FSO-21 and FSE-31.
- **Safe speed monitor (SSM)** provides information that speed is within the configured limits. Available only with FSO-21.



ACS880 machinery drive, frame size R1 with a safety functions module

Safety functions module (compatible with ACS880)

Option	Ordering code
FSO-12	+Q973
FSO-21+FSE-31	+Q972+L521 ¹⁾

¹⁾ For availability please check with your local ABB

Brake options

Brake chopper

The brake chopper is built-in as standard for the ACS380 and ACS880 drives. Braking control is integrated into the ACS880 machinery drives. It not only controls braking but also supervises system status and detects failures such as brake resistor and resistor cable short-circuits, chopper short-circuit, and calculated resistor over-temperature.

Brake resistor

The brake resistors are separately available for the ACS380 and ACS880 machinery drives. Resistors other than the standard option resistors may be used, provided that the specified resistance value is within specified limits and that the heat dissipation capacity of the resistor is sufficient for the drive application (see hardware manual). No separate fuses in the brake circuit are required if the conditions for eg, the mains cable is protected with fuses and no mains cable/fuse overrating takes place.

EMC – electromagnetic compatibility

The ACS380 machinery drives are equipped with a built-in filter to reduce high frequency emissions. For ACS880 machinery drives, all EMC filters are optional and may be internal or external depending on the drive model.

EMC standards

The EMC product standard (EN 61800-3) covers the specific EMC requirements stated for drives (tested with motor and cable) within the EU. EMC standards such as EN 55011 or EN 61000-6-3/4 are applicable to industrial and domestic equipment and systems including components inside the drive. Drive units complying with the requirements of EN 61800-3 are compliant with comparable categories in EN 55011 and EN 61000-6-3/4, but not necessarily vice versa. EN 55011 and EN 61000-6-3/4 do not specify cable length or require a motor to be connected as a load. The emission limits are comparable to EMC standards according to the table below.

Domestic environments versus public low voltage networks

1st environment includes domestic premises. It also includes establishments directly connected without an intermediate transformer to a low voltage power supply network that supplies buildings used for domestic purposes. 2nd environment includes all establishments directly connected to public low voltage power supply networks.

Comparison of EMC standards

EMC according to EN 61800-3 product standard	EN 61800-3 product standard	EN 55011, product family standard for industrial, scientific and medical (ISM) equipment	EN 61000-6-4, generic emission standard for industrial environments	EN 61000-6-3, generic emission standard for residential, commercial and light-industrial environment
1 st environment, unrestricted distribution	Category C1	Group 1, Class B	Not applicable	Applicable
1 st environment, restricted distribution	Category C2	Group 1, Class A	Applicable	Not applicable
2 nd environment, unrestricted distribution	Category C3	Group 2, Class A	Not applicable	Not applicable
2 nd environment, restricted distribution	Category C4	Not applicable	Not applicable	Not applicable

Need a motor? This is our offering.

Our machinery drives control virtually any type of AC motor including induction, permanent magnet, servo and synchronous reluctance motors. Our adaptable machinery drives ensure an energy efficient and reliable motor controller with significant cost savings for the user.

Direct torque control (DTC) for optimal control of motors

To ensure optimal control of an AC motor, our ACS880 machinery drives offer direct torque control (DTC) as a built-in standard feature. In majority of applications, the DTC reduces the need for an expensive speed feedback encoder. Direct torque control provides fast reaction to load changes in the motor shaft as well as reference changes on speed or torque made by the user. It makes the motor run optimally, lowering energy consumption and wear of the application.

Machinery drives and induction motors form a reliable combination

Induction motors are used throughout the industry in several types of industry applications which demand robust and high enclosure motor and drive solutions. The ACS880 machinery drives fit perfectly together with this type of motor, used in a wide range of industrial environments.

Machinery drives and permanent magnet motors for smooth operation

Permanent magnet technology is often used for improved motor characteristics such as energy efficiency, compactness and control performance. This technology is suitable eg, for low speed control industry applications, as in some cases they eliminate the need to use gear boxes. Actual characteristics between different permanent magnet motors can vary considerably. Machinery drives can control ABB's and most other permanent magnet motors in an efficient way.

Machinery drives and IE4 synchronous reluctance motors for a package with high efficiency

Combining the machinery drives control technology with our synchronous reluctance (SynRM) motors provides an IE4 motor and drive package that gives you great energy savings benefits. The key is in the rotor design. The synchronous reluctance rotor replaces the traditional induction rotor and requires no permanent magnets. ABB has tested the SynRM motor and drive packages and produced manufacturer's statements providing verified system (drive and motor efficiency).



Drives service

Your choice, your future

The future of your drives depends on the service you choose.

Whatever you choose, it should be a well-informed decision. No guesswork. We have the expertise and experience to help you find and implement the right service for your drive equipment. You can start by asking yourself these two critical questions:

- Why should my drive be serviced?
- What would my optimal service options be?

From here, you have our guidance and full support along the course you take, throughout the entire lifetime of your drives.

Your choice, your business efficiency

ABB Drive Care agreement lets you focus on your core business. A selection of predefined service options matching your needs provides optimal, more reliable performance, extended drive lifetime and improved cost control. So you can reduce the risk of unplanned downtime and find it easier to budget for maintenance.

We can help you more by knowing where you are!

Register your drive at www.abb.com/drivereg for extended warranty options and other benefits.



Service to match your needs

Your service needs depend on your operation, life cycle of your equipment and business priorities. We have identified our customers' four most common needs and defined service options to satisfy them. What is your choice to keep your drives at peak performance?

Is uptime your priority?

Keep your drives running with precisely planned and executed maintenance.

Example services include:

- ✓ Life Cycle Assessment
- ✓ Installation and Commissioning
- ✓ Spare Parts
- ✓ Preventive Maintenance
- ✓ ABB Drive Care agreement

Is rapid response a key consideration?

If your drives require immediate action, our global network is at your service.

Example services include:

- ✓ Technical Support
- ✓ Drive Exchange
- ✓ On-site Repair
- ✓ Response time agreements

Need to extend your assets' lifetime?

Maximize your drive's lifetime with our services.

Example services include:

- ✓ Life Cycle Assessment
- ✓ Replacement, Disposal and Recycling

Is performance most critical to your operation?

Get optimal performance out of your machinery and systems.

Example services include:

- ✓ Training



Drives service

A lifetime of peak performance

You are in control of every life cycle phase of your drives. At the heart of drive services is a four-phase product life cycle management model. This model defines the services recommended and available throughout the drive's lifespan.

Now it's easy for you to see the exact service and maintenance available for your drives.

ABB drives life cycle phases explained:

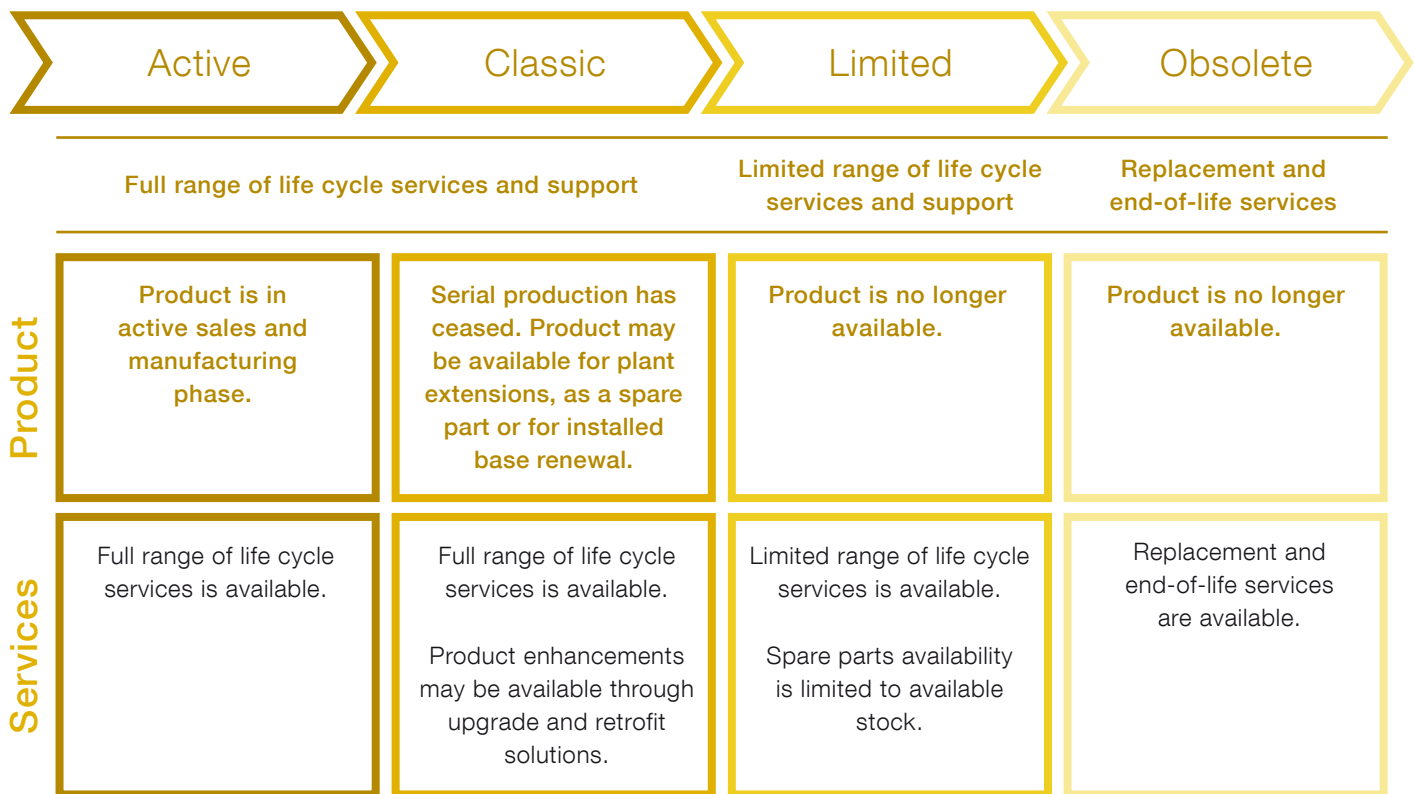

Keeping you informed

We notify you every step of the way using life cycle status statements and announcements.

Your benefit is clear information about your drives' status and precise services available. It helps you plan the preferred service actions ahead of time and make sure that continuous support is always available.

Step 1 Life Cycle Status Announcement

Provides early information about the upcoming life cycle phase change and how it affects the availability of services.

Step 2 Life Cycle Status Statement

Provides information about the drive's current life cycle status, availability of product and services, life cycle plan and recommended actions.

Contact us

www.abb.com/drives
www.abb.com/drivespartners
www.abb.com/motors&generators

© Copyright 2017 ABB. All rights reserved.
Specifications subject to change without notice.



441 024
Printed matter

3AUA0000187460 REV A EN 20.2.2017