

INTRODUCTION / DESCRIPTION

This manual describes the installation of Durant models 5775X-40X and 5775X-41X. Because of unique features, these counters may be used in a variety of applications. However, they are intended for use with pulsed output flowmeters; this manual will focus on their use in flow applications.

This manual starts with a general description of flow applications and the Eclipse. This should provide a useful reference point for the installer. Installers are the unsung heroes of industry who laugh in the face of the three most-feared words in the English language: Some Assembly Required. Installers are often given a vague objective and some equipment; in this case pipe, valves, a flowmeter, and a counter, with which to accomplish the mission. It is then up to the installer to use his knowledge and ingenuity to make the system work.

The installation section of this manual follows the description. This provides detailed information on mounting, wiring, and programming the Eclipse. The installation section uses terms that were explained in the description. Installation is normally the most complex aspect of the Eclipse, therefore the installation section is the largest section of this manual. The bad news is that the Eclipse is very versatile, and through wiring and programming variations, can solve a variety of applications. The manual must document all the possibilities. The good news is that most flow applications will not require all of the wiring and programming choices that are possible with the Eclipse. The key for the installer is to know what must be accomplished and to know what is in the Eclipse with which to do it.

There are three final sections in this manual. Run mode describes the operator functions of the Eclipse. Diagnostics explains the self diagnostics and error messages that may appear on the display. The last section is specifications.

Description

Forty (40) model variations of the Eclipse are covered by this manual. The Eclipse is either AC powered or DC powered. It consists of a base unit totalizer with 12 possible combinations of optional outputs, or a base unit batch control with 8 possible combinations of optional outputs. While reading this description, it is important to remember two things. First, all models can display flow rate. Second, the batch control, known simply as the "batcher" to its fans, does all of the functions of the totalizer. Check the part number breakdown chart on the next page to determine what your unit is made up of. Read the description section(s) to identify how those functions will be used in your particular application.

DESCRIPTION cont.

Eclipse Flow Model Numbers

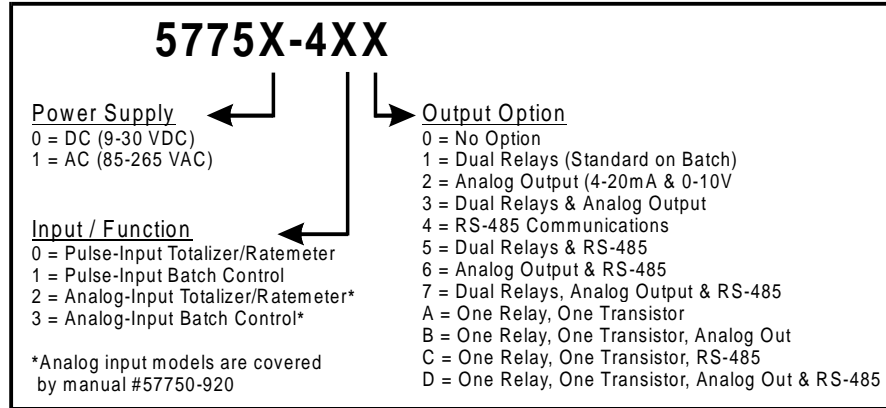

Base Unit

A **totalizer** is basically a counter that just counts. The Eclipse totalizer answers the questions “how much?”, and “how fast?”. A typical application for a flow totalizer would be a water meter for a building. As illustrated below, when a valve is opened inside the building, water will flow through the pipe that feeds the building from the water main. This flow causes the flowmeter to generate electrical pulses, sending it to the totalizer.

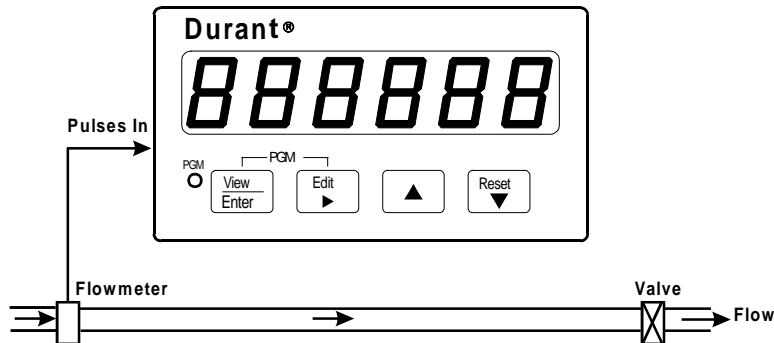

The totalizer accumulates these pulses and displays total water usage in gallons. The totalizer can also display flow rate in units such as gallons per minute, based upon how fast the pulses are coming in. All flowmeters are not created equal. Even though two flowmeters may be the same model, they probably put out a different number of pulses per gallon. The flowmeter manufacturer is aware of this and tests each flowmeter after it is built. The actual number of pulses that the flowmeter puts out per gallon (or pound, or liter, etc.) is known as the K factor, and is usually stamped

DESCRIPTION cont.

on the flowmeter's label. Fortunately, the Eclipse can do the arithmetic to convert pulses into familiar units of measure.

Once installed, normally only the front panel of the Eclipse totalizer will be visible. It will look like this:

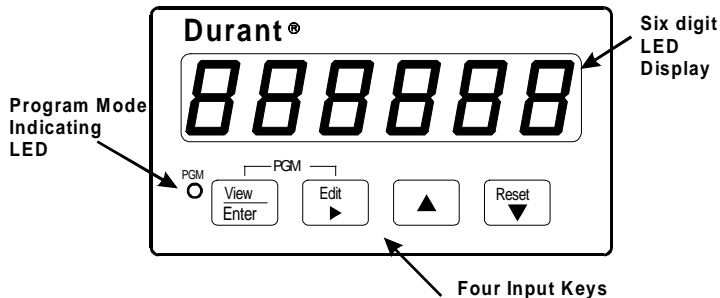

The LED display dominates the front panel. The operator will view the total and rate on this display. In totalizing applications, six digits (up to 999,999) is often not adequate. The installer has three options in this case, all available through programming.

1. The installer can program the Eclipse to divide the total by 10 (display up to 999,999 tens of gallons).
2. The installer can divide by 100 (display up to 999,999 hundreds of gallons).
3. The installer can display a 10 digit total in the form of the low five digits and the high five digits on successive screens.

The display will also be used by the installer for programming purposes.

The four input keys will be used primarily by the installer for programming purposes, but the operator can use them also for changing the display screen from total to rate, for example. The reset key is programmable. For the base unit, the reset key can reset the total, or do nothing for the operator.

The program mode indicating LED lets the installer know that he is in the program mode.

The totalizer base unit has a control input board installed that allows the installer to wire external switches to it to reset the total and to lock out the program mode from the operator. These inputs may also perform other functions if the relay option board is installed.

A **batch control** is a counter that opens a valve to allow flow to start and counts out a certain preset volume of liquid as entered by the operator. It then shuts off the valve after the "batch" has been delivered. This is a closed-loop control system. There are

DESCRIPTION cont.

two variations of batch control. The first, and most common is the single valve approach represented by the diagram below.

Single Valve Batch Control

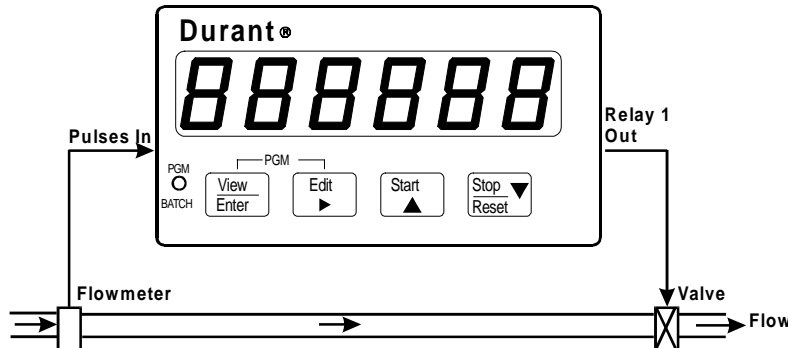

Assume that a cosmetics manufacturer has just blended a 100,000 gallon vat of his economy perfume, and that he wants to ship it to his customers in 55 gallon drums. The operator enters 55 into the **batch final** preset by using the keys on the front panel of the Eclipse batcher. When an empty drum is in place beneath the outlet pipe, the operator presses the **start** key. This causes the batch final relay, (relay 1) to turn ON, which in turn, opens the solenoid valve. With the valve open, perfume flows from the vat to the drum. The flowmeter detects the flow and sends pulses to the counter. The counter happily accumulates these pulses and counts up to 55. At this point, the batcher realizes that the amount delivered to the drum is equal to the amount entered by the operator in the batch final preset. The batch final relay turns OFF, shutting the valve. When the operator has removed the full drum and placed another empty drum under the outlet pipe, he again presses the start key and another batch of 55 gallons will be delivered.

Once the batch delivery has been started, it will normally shut off automatically at the batch final preset value. However, most users will want the ability to manually stop the delivery as well. Assume that the operator had started his 55 gallon batch, and then noticed that the drum had a hole in its side. The operator would then press the front panel **stop** key, which would immediately turn the batch final relay OFF, shutting the valve. Now the operator has a decision to make. Perhaps he can plug the hole with a piece of chewing gum. In this case, he makes the repair and resumes delivery of the batch from where he stopped by pressing the start key again. However, maybe the operator determined that the hole could not be repaired. Then he would terminate the batch by resetting the counter. The **resume** function, completing a batch after it had been manually stopped, and the **terminate** function, ending a batch after a manual stop, are necessary functions of a batch control.

DESCRIPTION cont.

The second batch application is the two valve approach that uses both internal relays of the batcher. Each relay controls a valve, as illustrated below:

Dual Valve Batch Control

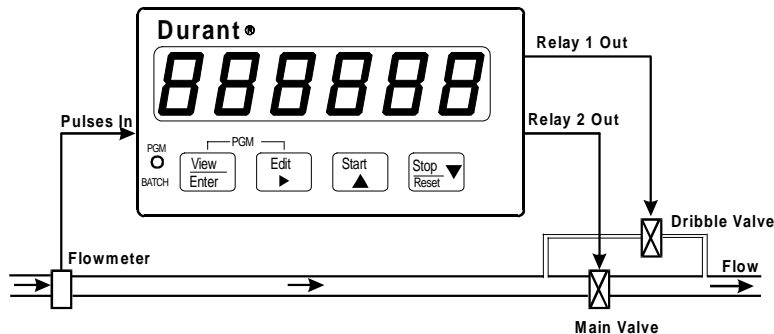

The cosmetics plant made the single valve installation and soon 55 gallon drums were being shipped out to customers everywhere. The installer stayed at the site to observe the operation of the system and insure that it met his high standards. Before long, the look of concern on the installer's face made it clear that he was not satisfied. Two things were troubling him. First, at the end of each batch, some extra perfume was always delivered. The installer recognized that this was a clear case of overrun. When the batcher delivered 55 gallons and turned OFF the valve, it took a certain amount of time for the valve to actually close. During this time some flow occurred. The amount of flow that occurs from the time that the batcher reaches the batch final count until flow actually stops is called **overrun**.

The second observation that concerned the installer was the pounding that his delicate plumbing took each time the valve closed. It was obvious that the shock of going from a full flow state to a no flow state in less than one tenth of a second would eventually cause an unauthorized exit in the system - a leak.

The installer knew that the solution for both problems was to use the dual valve approach. This meant installing a small pipe around the valve. This pipe, the dribble pipe, would also be equipped with a valve, known as a dribble valve. The dribble valve is controlled by the batch final relay (relay 1), and the main valve is controlled by relay 2, which is programmed to be the batch prewarn output. This fiendishly clever setup operates in a simple manner. When a batch is started, both relays turn ON, both valves open, and flow commences at a full flow rate. At a set value before the batch final preset is reached, the prewarn relay turns OFF, closing the main valve, and flow is reduced to the dribble rate. When the batch final preset is reached, the batch final relay turns OFF, shutting the dribble valve and stopping the flow.

The "set value before the batch final preset" is the **batch prewarn preset**. It will probably be set by the installer. The batcher does the arithmetic internally to deter-

DESCRIPTION cont.

mine at what batch count value the prewarn relay should turn OFF by subtracting the batch prewarn preset from the batch final preset. Assume batch prewarn is set to 3. When filling 55 gallon drums, the prewarn relay shuts off the main valve when the batch reaches 52 gallons (55 minus 3). Should the operator decide to fill 30 gallon drums, he simply changes the batch final preset to 30. The batcher would then shut off the main valve when the batch reaches 27 gallons (30 minus 3). Although the installer knows that prewarn operation is the result of careful planning, to the operator this has the appearance of magic. The batcher always “knows” when to shut off the main valve, regardless of the preset batch size. If the operator concludes that the installer has the power to create the mythical “anticipating relay”, it is not our duty to confuse him with the facts.

Already some installers are thinking of other ways to use the batch control outputs. For instance, some may wish to use the batch final relay to control a valve, and the batch prewarn relay to operate a pump. This manual simply cannot cover all the possibilities.

Once installed, normally only the front panel of the Eclipse batcher will be visible. It will look like this:

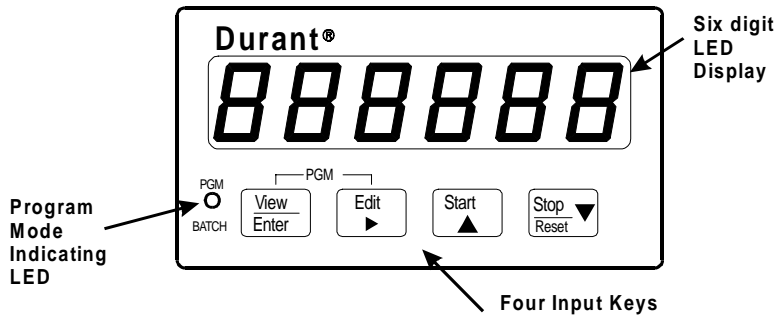

The LED display dominates the front panel. The operator will view various counters, presets, and the rate on this display. The installer will view and edit programming selections on the display.

The four input keys have operator and installer functions. The operator may use them to change display screens from count, to preset, to rate, etc. and possibly to reset counters. The operator may also use these keys to start, stop, resume, and terminate batch delivery.

The program mode indicating LED lets the installer know that he is in the program mode when it is ON. This LED will flash ON and OFF for the operator when a batch is running. Once a batch has been stopped, either manually or automatically, the LED will remain OFF until another batch is started.

The installer is probably now thinking “well, it seems that we have batch delivery pretty well covered, but how about those totalizer functions that this thing is sup-

DESCRIPTION cont.

posed to do?" This manual is glad you asked that question. There are actually two other counters inside the box. One is a totalizer that counts along with the batch counter. However, while the batch counter is reset at the beginning of each batch, the totalizer is not reset; it continues to count up. The cosmetics manufacturer resets his totalizer each time he blends another 100,000 gallon vat. As the batch counter delivers 55 gallon drums, the totalizer counts the total amount delivered. When the totalizer reaches 100,000, it is time to blend another vat of perfume and reset the totalizer.

The third counter is the cycle counter. The **cycle counter** keeps track of how many batches had been delivered; it counts the number of batches. The mere presence of the cycle counter opens the door to some interesting variations of batch delivery automation. The batch counter may be programmed to **auto recycle**. This is done by programming a time in the range of 0.1 to 9.9 seconds for batch recycle time. In this case, the operator starts the initial batch manually. Once the first batch is delivered, the batcher stops for the duration of the auto recycle time and then automatically starts another batch. This may continue until the operator manually stops the process with the cycle counter showing the number of batches run. However, the cycle counter has a setpoint, called **cycle preset**, which will stop the process automatically after that number of batches has been delivered. This type of operation is known as **cycle autostop**. If a batch autorecycle time of 0.0 is programmed, the batcher stops after each batch has been delivered, and each batch must be manually started by the operator.

Two other things can happen when the cycle counter reaches the cycle preset, cycle reset and cycle output. The cycle counter will automatically reset to zero if it is programmed to reset at **cycle setpoint**. This feature would normally be employed in combination with the use of an output at cycle setpoint. If both relays are already used to deliver the batch, or if relay 2 is used for another function, this will not be possible. Refer to the relay output option description on page 31. If relay 2 is available to be used as a cycle output, the cycle counter can cause any combination of the following events at the cycle preset value:

1. Cycle autostop or no autostop.
2. Cycle counter reset or continue to count up.
3. Cycle output or no output.

When all is said and done, most users will simply use the cycle counter to count batches and nothing else. However, the installer will certainly appreciate knowing the possibilities.

There are a few final points to be made about the batcher's base unit. First, it also provides an alarm output at a preset rate, if relay 2 is not used for another function. Second, the relay output board, an option for the Eclipse totalizer, is always included in the batcher. The outputs are described in the relay output option description on page 8. Third, a control input board is installed in the unit. The board has three

DESCRIPTION cont.

inputs that may be programmed to do a number of functions such as counter(s) reset, unlatch outputs, program mode lockout, and the batch control start and stop functions.

Relay Output Option Board

Two types of output boards are available for the Eclipse. One is a dual relay as indicated by the last digit of the part number being a 1, 3, 5, or 7. The other is a single relay/single transistor as indicated by the last digit of the part number being an A, B, C, or D. In either case, output 1 is a relay. One of the output option boards is standard in the batch control unit. Output 1 is dedicated as the batch final output in the batcher. Output 2 can be programmed to one of the totalizer output functions described below, or to the batch prewarn or cycle setpoint function. The batch prewarn output is described on page 5. As a cycle setpoint output, it will turn ON when the cycle count reaches the cycle preset value, and turn OFF either after a programmable time in the range of 0.01 to 99.99 seconds elapses, or after an unlatch 2 input occurs. The unlatch input can be either a control input or a front panel key programmed to unlatch 2.

If the output board is installed in a totalizer base unit, either output can be programmed to perform one of the following totalizer output functions:

1. Totalizer setpoint. This option is not available if the totalizer is programmed to 10 digit total. Turns ON when the totalizer counts to a number greater than or equal to the totalizer preset value. Turns OFF either after a programmable time in the range of 0.01 to 99.99 seconds elapses, or after an unlatch input occurs. If the output is programmed to latch (no timeout), the output will be checked at each input pulse until an unlatch input occurs, even after power has been cycled OFF and then ON to the unit.
2. Rate low setpoint. Turns ON when the rate is less than or equal to the rate low setpoint. However, from a start condition (power up for the totalizer; batch start for the batcher), the rate reading must first become greater than or equal to the rate low setpoint before this alarm feature is enabled. Turns OFF after a programmed timeout in the range of 0.01 to 99.99 seconds, or when an unlatch input occurs, or when the rate becomes greater than the setpoint (follows mode). This output is updated each time the rate display updates.
3. Rate high setpoint. Turns ON when the rate is greater than or equal to the rate high setpoint. Turns OFF after a programmed timeout, or when an unlatch input occurs, or when the rate becomes less than the setpoint (follows mode).
4. Rate low-high setpoint. Turns ON when the rate is less than or equal to the rate low setpoint, OR is greater than or equal to the rate high setpoint. If the rate low setpoint is greater than the rate high setpoint, the output will be ON when the rate is greater than the rate high setpoint AND less than the rate low setpoint. Follows mode only.

DESCRIPTION cont.

5. Totalizer pulse output. Puts out a timed pulse for each totalizer count. This signal is intended to go to a remote totalizer. The pulse width ON time is selectable to be either 500 +/- 84 μ sec, 2 msec, or 50 msec. The minimum OFF time is the same as the ON time. Regardless of the totalizer display mode selected for the Eclipse (i.e. divide by 1, 10, or 100), the totalizer pulse output operates in the divide by 1 mode. The totalizer pulse output has a 9,999 count register. Because of the nature of this output, it is recommended that a transistor output be used for this function.

Analog Output Option Board

Sometimes known as analog retransmission, the installer can assign the output to follow displayed rate, or total, or batch count, or cycle count. Both 4-20 mA and 0-10V outputs are given; however they are not independently programmable. The installer programs not only the assignment, but the offset and full scale values. Both outputs follow the assigned count or rate and go from minimum value (4 mA and 0V) to maximum value (20 mA and 10V) as the displayed count or rate goes from offset value to full scale value. Both outputs are electrically isolated from all other circuitry inside the Eclipse.

RS 485 Serial Communications Option Board

This option board allows a host device, such as a computer, to download and read programming selections, and to perform most of the run mode operator functions such as read count and rate, enter setpoints, reset counters, and start and stop batch delivery.

This manual does not contain information on the serial command protocol or the serial command list. That information is contained in the 57750 serial specification and obtainable by contacting the Durant Literature Department at 800-540-9242 (US and Canada), or 920-261-4070, or by FAX at 920-261-9097.

MOUNTING

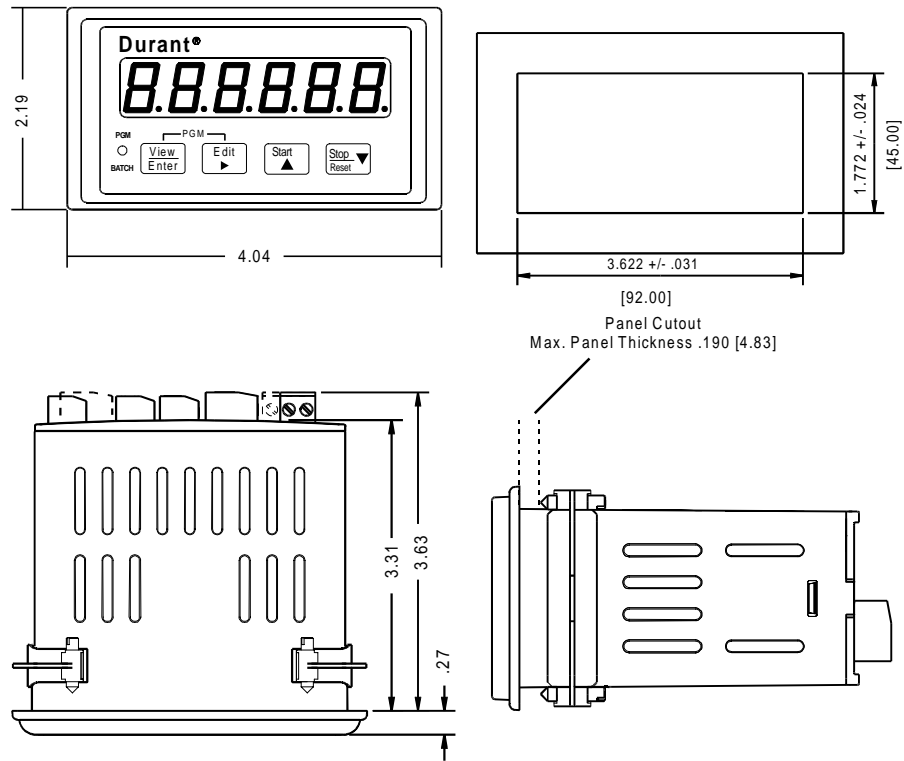

Mounting Instructions

1. Slide mounting gasket (not shown) over unit body until adhesive surface makes contact with the front bezel.
2. Slide unit into cutout in panel.
3. Attach mounting clips and screws.
4. Tighten screws until unit is firmly in place. **DO NOT OVERTIGHTEN** screws to the point of squeezing the gasket out from behind the bezel.

WIRING

WIRING AND DIP SWITCHES

All wiring to the counter is done to rear terminal, de-pluggable connectors. Up to six headers accept the wired connectors on the counter. All units have at least three headers, power input, count input and control input. The relay output header is installed in the batch control base unit and is optional for the totalizer. Any combination of two additional circuit boards with headers may be installed. These option boards are RS 485 serial communications and analog output. The option boards occupy specific locations in the counter and are not interchangeable. All boards are keyed to prevent installation in the wrong location.

 Disconnect all power before wiring terminals. **A safety hazard exists if this precaution is not observed. Treat all control and count inputs as hazardous since they carry line voltage.**

A switch shall be included in the building installation:

- It shall be in close proximity to the equipment and within easy reach of the operator.
- It shall be marked as the disconnecting device for the equipment.
- Switches and circuit breakers in Europe must comply with IEC 947.

Rear Terminal Layout

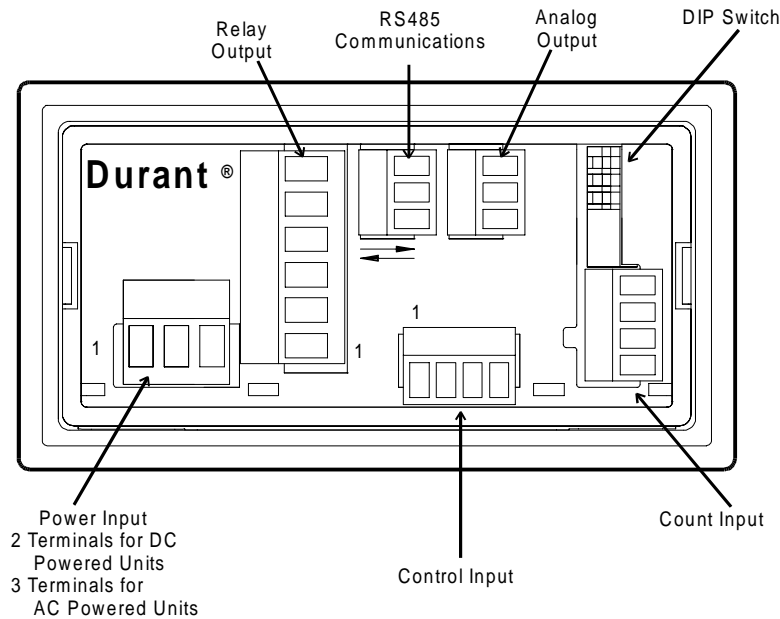

WIRING cont.

Terminal Connector Ratings

AC or DC Power Input / Relay Output: 10A, 250VAC;
 Wire size: 12-24AWG (3.1mm² - 0.24mm²), 600V.
 RS485 / Analog Output / Flowmeter Input / Control Input: 8A, 125VAC;
 Wire size: 16-28AWG (1.3mm² - 0.1mm²), 300V.

DC Power Input (for DC powered models 57750-4XX)

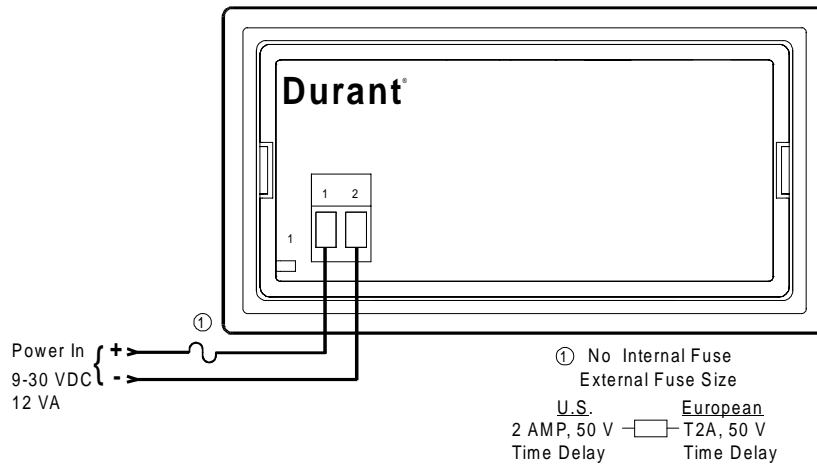

AC Power Input (for AC powered models 57751-4XX)

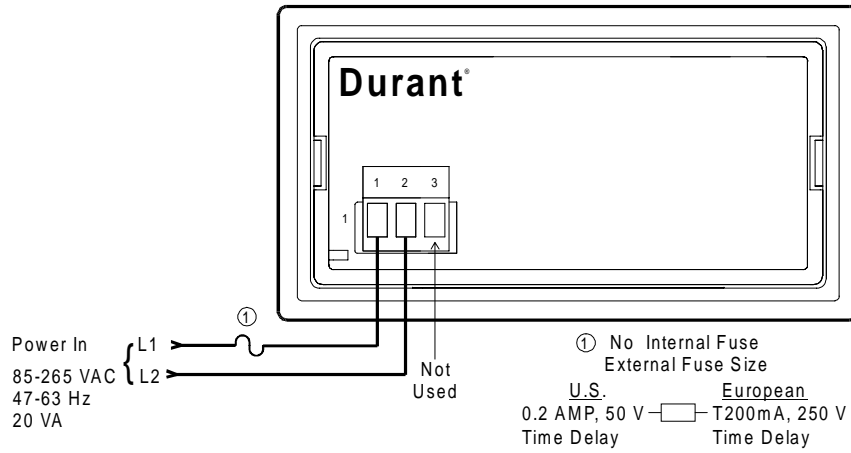

WIRING cont.

Programming Considerations for Power Up Operation

What can there possibly be to program that has anything to do with power wiring? Considering this from the operator's perspective, what does he expect to see when he turns on the power? The default menu column "d" (page 28) has four (4) programming blocks. The set default blocks d3 and d4 are the domain of the installer or maintenance person, but the other two blocks affect what the operator can see and do at power up. Block d1 sets the power up display. Should the unit always display rate, or count at power up, or should it just come up to the display that was showing when the power went down? Block d2 determines what the totalizer displays, either a six digit total in divide by 1, or 10, or 100 mode, or a 10 digit total.

Speaking of the front panel keys, what should they do for the operator? The program mode is entered using these keys, but it is a good idea to lock out the program from the operator. This is done by programming a control input (in column "L", page 29) to do one of the lockout functions and then wiring that input to common as shown in the control input wiring diagram. For totalizers with the relay option and for all batchers, the reset key may perform an output unlatch function as well as, or instead of, the reset function. This is set by programming block L4. Batchers have start and stop keys available to the operator. Both keys can do one or more functions depending upon the choices made in blocks L5 and L6 respectively.

WIRING cont.

Flowmeter Input Wiring and DIP Switches

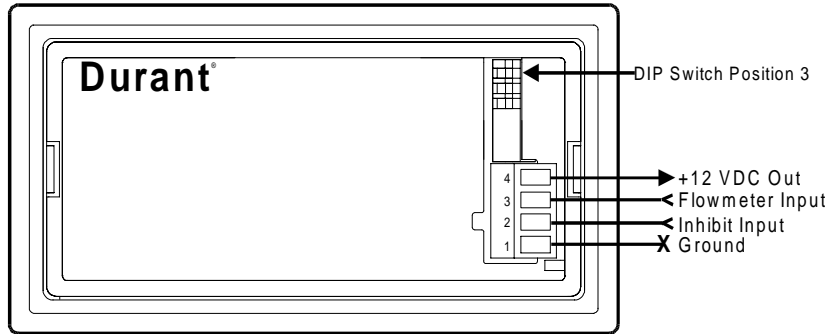

Typical Flowmeter wiring (3⊗ denotes terminal number)

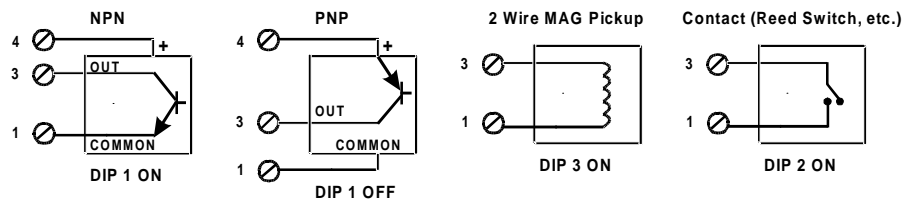

The inhibit input (2⊗) is wired the same way, and DIP switches 1, 2, and 3 are set accordingly.

Sensor Power Out
12 VDC +/- 12%, 75 mA max, short circuit protected

Dip Switch Settings

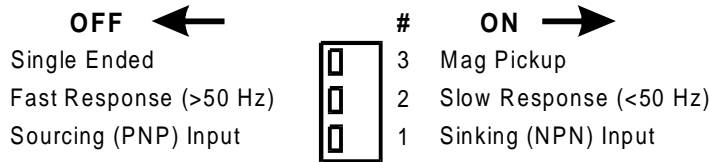

WIRING cont.

Programming Considerations for Flowmeter Input and DIP Switch Definitions

The inhibit input will normally not be used. The count inhibit function means that the counter will ignore flowmeter pulses when inhibit is active. This is handy at some times, such as when the system is being purged. However, experience has shown that most users do not care to use this function. Inhibit inputs on counters around the world are aware of this fact; because of it, inhibit inputs generally suffer from lack of self-esteem. Inhibit inputs are the original Maytag® repairman. Durant is a sensitive, caring counter manufacturer that has decided to do something about this. The inhibit input on the Eclipse is programmable (in block F1, page 26) to either do its traditional inhibit duty, or to select between two pre-loaded K factors. This opens up a number of application possibilities, some bizarre, some simply clever. If one K factor is the number of pulses per gallon and the other K factor is the number of pulses per liter, the user can go from counting in gallons to counting in liters and vice versa simply by throwing a switch. Gallons to pounds conversion is another likely scenario.

Setting the DIP switches can be an adventure since there are a wide variety of flowmeter types and there is no standard output pulse signal. Furthermore, signal conditioning devices, such as flow transmitters, may change the electrical characteristics of the signal. The most common flow signal is a differential, AC voltage generated by a paddlewheel flowmeter. This is a two wire signal, and the output frequency can easily exceed 200 Hz. Mag pickups are sink and source, so don't worry about DIP switch 1, just turn 2 OFF and 3 ON. Contact outputs, such as reed switches, are much less common. They can be set up as sink, as shown in the diagram, or source. Since the diagram shows how to wire them as sinking sensors, use that method. Contact inputs will always be low speed, so switch 2 is ON.

Transistor output signals are generally three wire, since the transmitter usually requires DC operating power. The Eclipse puts out 12 VDC for these types of sensors. Transistors are either NPN or PNP. NPN outputs are sinking outputs; they provide the path to ground. PNP outputs are sourcing; they provide the path to positive. These signals are considered "single ended" because they are referenced to common (ground). They can easily be high frequency signals. Switches 2 and 3 should be OFF, and switch 1 is OFF for PNP, and ON for NPN.

WIRING cont.

Control Inputs

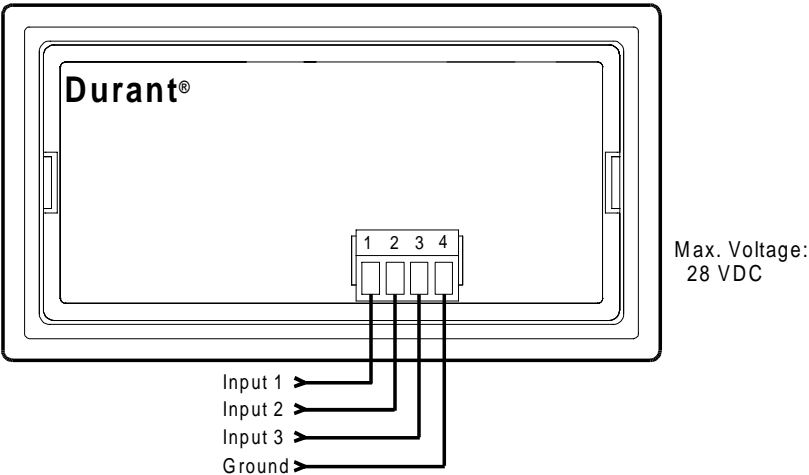

The control inputs are pulled up to +5VDC through a 4.75k Ω resistor. Control inputs require current sinking (NPN) sensors, or contact closures to ground.

Typical Wiring

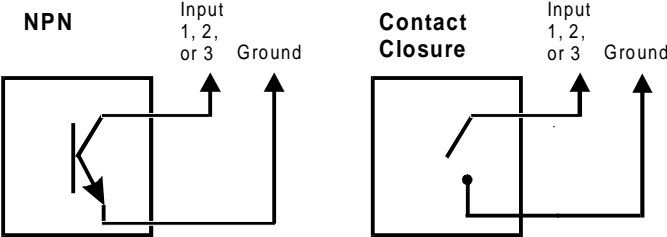

WIRING cont.

Programming Considerations for Control Inputs

All models of the Eclipse have three control inputs. The installer is advised to use one of them as a lock input. When activated by a jumper, the lock input will prevent the operator from making unauthorized changes to the program. Programming an Eclipse to exactly perform a certain function can be compared to creating a beautiful, horse-drawn carriage. Don't let the third shift operator change it back into a pumpkin by ignoring the lock input feature.

A control input may be used to reset one or more counters in the Eclipse. This means that an external pushbutton can be used instead of, or along with, the front panel reset. For instance, the user may want the operator to reset the batch count with the front panel reset and allow a supervisor to reset the totalizer with a key lock reset switch.

If the unit has an output programmed to latch at one of four setpoints; namely totalizer, cycle, rate high, or rate low, a control input may unlatch the output. There may be occasions where two outputs are latched. A control input may be programmed to unlatch either, or both of the outputs.

The front panel start and stop key functions of the batcher may be duplicated by control inputs. However, remember that if the batch is manually stopped before the batch is complete, the start input always resumes the batch unless the batch counter is reset. In order to remotely start, stop, and terminate the batch, three inputs must be used. This does not allow for an input to be used for the lock function; sooner or later the Eclipse may become a pumpkin. In most applications, the front panel start and stop keys will be used, but it may be handy for an operator to be able to stop delivery from a remote location by using a control input.

Control inputs may be programmed to perform multiple functions as long as the functions are not mutually exclusive, such as start and unlatch output 1. An input could be programmed to do up to three functions, such as start, reset the batch counter, and unlatch a rate alarm output. If an input is programmed to a lock function, then it cannot be programmed to also perform a start, stop, unlatch, or reset function.

The lock function is considered a maintained signal, meaning that the lock is active as long as the lock input is connected to ground. Normally this is done with a jumper wire, but occasionally the installer will employ an NC keylock switch. All other control input functions, as well as the front panel key functions are momentary signals. This means that the start, unlatch, reset, etc. function occurs immediately upon switch closure, and then the Eclipse ignores the input until the switch opens, and then closes again. Therefore, momentary pushbuttons are appropriate for control inputs programmed for any function except lock.

Programming column L contains three blocks for the control inputs, one for each. Column L also contains a block for the reset key function(s), and for the batcher, a block each for the start and stop key function(s). Taking into account the type of unit

WIRING cont.

(totalizer, totalizer with relays, or batcher) and the functions necessary for the particular application (reset, unlatch, start, etc.), determine the function(s) of each control input and select an input device appropriate to the function.

Relay Output

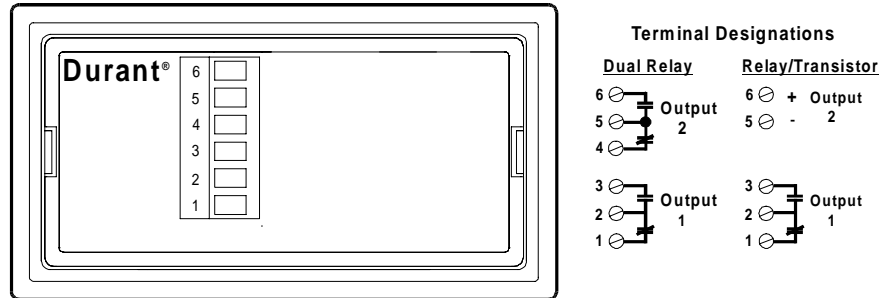

Typical Wiring

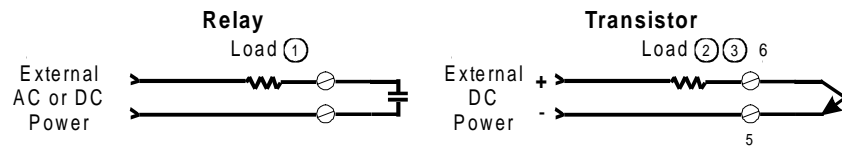

Relay Contact Ratings

5 A @250 VAC or 30 VDC maximum

Transistor Ratings

OFF state: Block 30 VDC max, 0.1 mA max leakage current

ON state: Conduct 50 mA max, 1.2 V max C-E voltage drop

- ① An RC surge suppressor is recommended across all inductive loads.
- ② The transistor is optically isolated and may be connected as a sink (shown), or a source by wiring the load between terminal 5 and - (minus).
- ③ A reverse-biased diode (1N 4001 or equiv.) is recommended across all inductive loads.

General Wiring Practices

- Use shielded cables for signal and control inputs.
- Keep all signal lines as short as possible (<30M or 100 ft.).
- Do NOT bundle or route signal lines with power or machine control wiring.
- Do not allow signal or control wires to leave the building.

WIRING cont.

Programming Considerations for the Output Board

Programming for the outputs is done in column “r”. If your unit is a totalizer **and** does not contain the optional output board, your unit will not have column “r” in the program mode, and you can skip this page and go on to the RS 485 communication wiring. All of you that have either a totalizer with the output board option, or a batcher, stick around.

OK, now that those guys are gone, we can talk behind their backs. And what we’re going to talk about is outputs. Output boards come in two varieties: a dual relay and a single relay/single transistor. Check the part number on your unit and compare it to the model selection table on page 2 to determine which flavor you have. Output 1 is always a relay, and is connected to terminals 1, 2, and 3. Output 2 is either a relay connected to terminals 4, 5, and 6, or it is an optically isolated transistor connected to terminals 5 and 6. The transistor output is generally used for the totalizer pulsed output if that function is required. Relays are normally used for all other output functions.

In the batcher, output 1 is not programmable. It is dedicated as the batch final relay. It turns ON when the unit receives a start input, and turns OFF when the batch final setpoint is reached, or when a stop input is received. Output 2 in the batcher and both outputs in the totalizer are programmable. When dealing with these outputs, there are two things to consider: when to turn ON, and when to turn OFF.

Turning ON will always be determined by an “event” appropriate to the function that they are programmed to do. For the totalizer, there are three events that can cause an output to turn ON:

1. When the totalizer count reaches the totalizer setpoint value (total setpoint).
2. When the flow rate crosses a setpoint value (rate low, rate high, rate low or high).
3. Each time a unit of flow is counted (totalizer pulsed output).

Output 2 in the batcher may also turn ON at any one of these events, or may turn ON at one of two others. They are a start input (prewarn setpoint) and when the cycle count reaches a setpoint value (cycle setpoint).

Turning OFF will either be determined by an event or by timing. There are four possibilities. Totalizer pulsed outputs are **pulsed** and turn OFF either after 500 +/- 84 μ sec (pulse fast), or 2 μ sec (pulse medium), or 10 μ sec (pulse slow). Totalizer setpoint, rate setpoint, and cycle setpoint outputs may be timed or latched. **Timed** outputs allow the installer to program an ON time in the range of 0.01 to 99.99 seconds. When this time elapses, the output(s) turn OFF. **Latched** outputs turn off when an unlatch event occurs. This event can be a start, stop, or reset input, or a control input programmed as unlatch. Rate setpoint outputs will turn OFF when the rate drops below a rate high setpoint, or goes above a rate low setpoint if the output is in the **follows** mode.

WIRING cont.

In the batcher, the batch final output and the batch prewarn outputs are latched. However, they are not programmable. They always turn ON at a start, and turn OFF at a stop, or when the count reaches their setpoint value. They do not respond to any other turn ON or turn OFF event, including an unlatch input. Keep in mind that a start may be generated internally by programming a batch autorecycle time in program block b-3. If this is done, once a manual start initiates the first batch, the unit will stop, wait for the timeout period, and then automatically re-start another batch. Automatic batch delivery will continue until either a manual stop input occurs, or until a preset number of batches is delivered if the cycle autostop feature is selected in block b-4.

RS 485 Communication Option Board

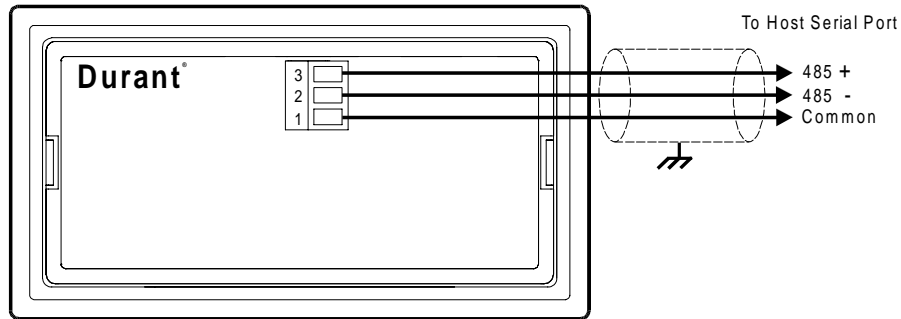

Analog Output Option Board

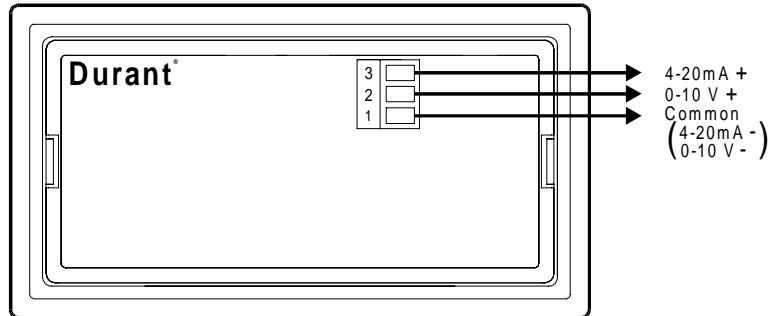

Output Ratings

4-20 mA into 750 Ω (Ohms) maximum

0-10 V into 2500 Ω (Ohms) minimum

PROGRAMMING

Programming defines the Eclipse's personality. If the installer wants the unit to act like an orange, he must program it to act like an orange. If the installer wants the unit to act like an apple, he must program it to act like an apple. Of course, some creative installers will program units to act like fruit salad. The Eclipse hardware can be used in a wide variety of ways; how the hardware works depends upon how the unit is programmed.

The program resides in the unit's memory, in an area so small that it cannot be seen by the human eye. If we were to magnify this area in our mind's eye, we could think of the program as a series of columns, with each column being made up of blocks, as represented in the diagram below:

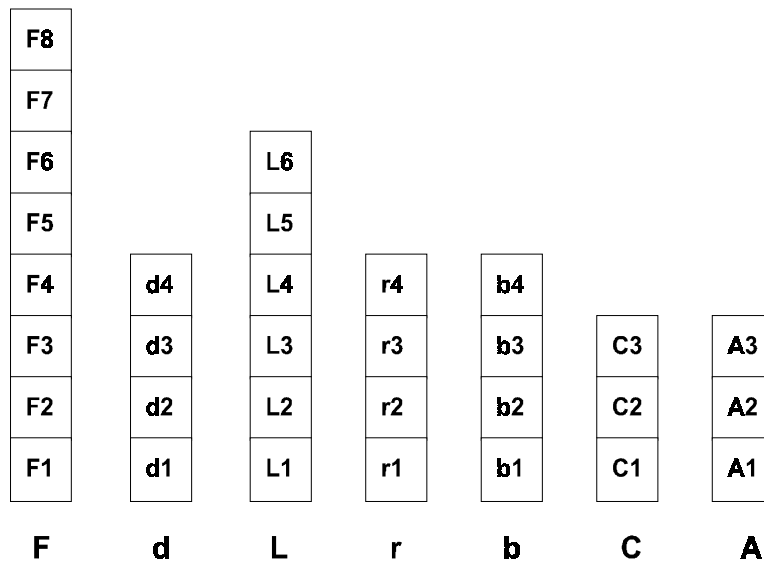

Each block has a name and a value, selected from a range of values, and each block is associated with a particular programmable feature of the unit called a parameter. In the program mode, the microprocessor is able to access these blocks, and fortunately for all of us who are not Superman, put the names and their values up on the display. Programming is accomplished by entering the "right" value for each parameter. For instance, program block F1 is the K factor 1 parameter. If the flowmeter has a K factor of 25.3 pulses per gallon, the installer would enter 25.300 into this block.

Each column contains parameters that are related to a general function of the Eclipse. Column F (Factors) is made up of parameter blocks that handle the count and rate scaling, which convert raw flowmeter pulses into meaningful count and rate displays. Column d (defaults) is somewhat of a miscellaneous collection of display and totalizer mode parameters. It also contains the blocks where the default pro-

PROGRAMMING cont.

gram and default run data commands reside. Column L (control inputs and keyboard) consists of blocks that assign the functions of the control inputs and the front panel keys. All Eclipse units have these three columns.





Batchers, and totalizers equipped with the relay output board, will have column r (relays). The blocks in column r assign the relay functions. Totalizers without relays do not have column r.

All batchers come with column b (batch control functions) as standard equipment. The parameter blocks in b determine what is shown to the operator in the batch count display, manual or automatic timed batch operation, and the cycle counter's role in batching. No totalizer has column b.

The two remaining columns, C (Communications) and A (Analog Output), will appear in any unit that has respectively, the serial communications board option, or the analog output board option installed. Column C sets the unit address, baud rate, and parity. Column A assigns the analog retransmission function, and sets the offset and full scale values.

The block diagram on page 21 shows all columns and all blocks. Only batchers with the communications and analog output options will have all programming columns. Lesser units will have columns missing, appropriate to the functions that are missing. Additionally, totalizers will have blocks missing in column L. Totalizers do not have start and stop keys, therefore blocks L5 and L6, which program these keys, are AWOL.

Once in the program mode, the installer will use the front panel keys to navigate from column to column and from block to block. While navigating around, the display will show the block name; for instance, F1 or r3. The block name is like a front door address that is used to locate each parameter that must be programmed. Behind the front door is where the parameter value lives. The value is a number that tells the parameter how to behave. Changing the value changes the behavior of the parameter. The majority of the remainder of this section will deal in detail with parameters and their values, but before we can get into that, we must first discuss how to surf from block to block.

Whenever you go into the program mode, you will always enter at block F1. Skeptics are welcome to try this for themselves. Pressing the  key displays the block name; in this case, F1. While holding the  key, pressing the  key scrolls the display up through F8. Since F8 is the last block in the F column, scrolling up from F8 wraps around back to F1. Scrolling down through a column is done by holding the  key and pressing the  key, as illustrated on next page:

PROGRAMMING cont.

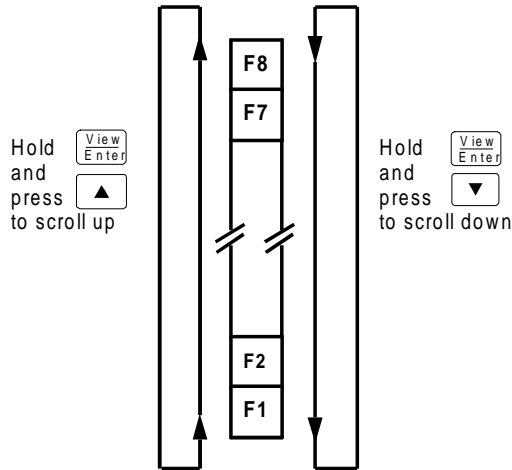

To scroll from column to column, while holding the **View Enter** key, press the **Edit** key. The display will land on the bottom (1) block of the next column to the right, as illustrated below. Note that since there is no **◀** key, scrolling to the left is undefined.

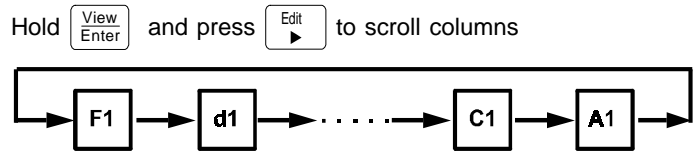

Upon arrival at a new block, release the **View Enter** key to display the parameter value. Parameter values will always be a number. The range of numbers available will depend upon the parameter. For instance, the totalizer display mode parameter has four possible values in block d2: 0, 1, 2, and 3. A value of 1 means that the totalizer will be divided by 1 to display whole units (gallons, liters, etc.). A value of 2 means that the totalizer will be divided by 10 to display tens of units. In order to change totalizer display from total divided by 1 to total divided by 10, change the value in block d2 from 1 to 2.

PROGRAMMING cont.

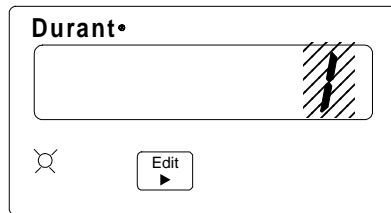

To change a value,

1. Press the  key:



Indicates flashing portion of display.

the most significant digit of the value will flash.

2. Use the  or  key to change the value of the flashing digit:

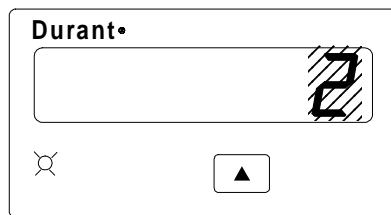

Indicates flashing portion of display.

3. Press the  key to enter the new value and display 2.

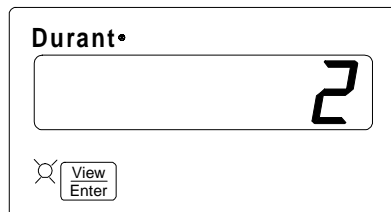

Flashing stops.

PROGRAMMING cont.



Entering the Program Mode

Note: It is recommended that upon installation, one of the control inputs be programmed to one of the Lock Functions, and then activated via a jumper to ground to prevent inadvertent operator entry into the program mode. If the program mode must be accessed after installation, remove the jumper wire and follow the procedure below.



Caution: Entry into the program mode will cause both relays, if installed, to turn OFF, and will cause the analog output, if installed, to go to its minimum values (4 mA and 0V).

To enter the program mode,

1. Press the  and  keys simultaneously.

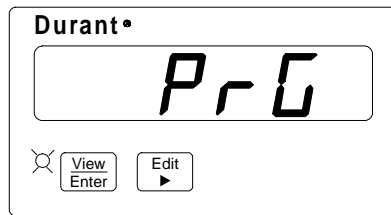

The program LED will turn ON, and the display will show Pr G (program) for one second, then show F1 for one second, and then show the value selected for programming block F1.

Exiting the Program Mode

To exit the program mode, press the  and  keys simultaneously.

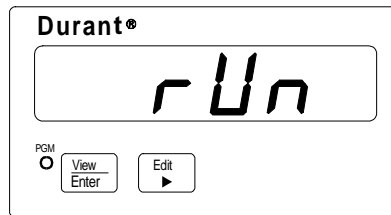

The display will show rUn. When the keys are released, the program LED will turn OFF, and the display will show the value of the default run mode display.

PROGRAMMING cont.

Programming Parameters

The programming columns are listed below, column by column. Each block name, the parameter that it represents, the default value, and the range of values is listed in the order in which the blocks appear when scrolling up through the column. There may be some blocks that will cause the installer to wonder "should I do anything with this, or not?" A comments section follows each column breakdown. These sections attempt to provide some practical information that the installer may find helpful in making programming choices.

Column F - Factors

Block	Parameter	Range (default Value is Bold)
F1	Count Factor Select	0 CF1/CF2 select by front panel 1 Count Factor 1 only 2 Count Factor 2 only 3 CF1/CF2 select by inhibit input
F2	Count Factor 1	0.001-99999 1.0000
F3	Count Factor 2	0.001-99999 2.0000
F4	Count Display Decimal point	0 XXXXXX 1 XXXXX.X 2 XXXX.XX 3 XXX.XXX 4 XX.XXXX
F5	Rate Display Decimal point	0 XXXXXX 1 XXXXX.X 2 XXXX.XX 3 XXX.XXX 4 XX.XXXX
F6	Rate Time Unit # of Seconds	1-99999 60
F7	Rate Smoothing Factor	1-9
F8	Rate Zero Time	1-9

PROGRAMMING cont.

The count factor (CF) is the K factor of the ratemeter. Normally only one count factor will be used. If so, leave F1 at the default setting of 1, enter the K factor into F2, and skip F3. If two K factors are to be used, only one can be active at a time. The active count factor will be selected via the front panel keys if F1 is set to 0, or will be selected via the rear terminal inhibit input if F1 is set to 3.

The Eclipse internally calculates a count scaler based upon the K factor and another factor, that it deduces from the count decimal point location. This will not be on the test, but for those curious installers who want to know what the formula is, it is:

$$\text{Count Scaler} = \frac{10^{(\text{F4 value})}}{\text{K Factor}}$$

The result of the calculation must fall in the range of 0.0002-99999. Since this is an extremely wide range for a count scaler, most values for F2 and F4 will work. Every time a K factor is entered, the Eclipse calculates the new count scaler just to make sure that it's in range. If it is, it accepts the number and displays the result of the calculation for one second. If the calculated scaler falls out of the range, the new K factor value is not accepted, and an error message "bad C1", or "bad C2" appears on the display. Every time a new F4 value is entered, the Eclipse calculates the new count scalers for both K factors (even if only one is used), and checks to see that they are in range. If they are, everything is hunky dory. If one or both are out of range, it will not accept the new count decimal location that is being changed in F4, and it will display the appropriate error message(s).

The count display decimal point shows on the totalizer and batch count displays.

The Eclipse also uses the K factor to calculate a rate scaler. The calculation includes another factor, deduced from the rate display decimal point location as determined by block F5, and also the number of seconds value entered into F6. The rate scaler formula is:

$$\text{Rate Scaler} = \frac{(\# \text{ of seconds}) \cdot (10^{(\text{F5 value})})}{\text{K Factor}}$$

The result of his calculation must fall in the range of 0.001-9999. The rate scaler is calculated every time a K factor (F2 or F3), or the number of seconds (F6), or the rate decimal point location (F5), is changed. Any calculated rate scaler that falls outside the range will cause the Eclipse to not accept the new value, and to display the error message "bad r1", or "bad r2", or both.

The rate smoothing factor parameter F7 provides a filtering effect on the rate display when flow rate changes. The ratemeter updates every 0.5 seconds. Since the rate-meter is deadly accurate, if flow rate changes, the rate display will change. In some systems, the rate display will bounce around due to fluctuations in flow rate. A rate smoothing factor of 1 causes no filtering to occur. This is useful when the user must

PROGRAMMING cont.

be quickly made aware via the display or a rate alarm output, of minor variations in flow rate. As the smoothing factor increases, the rate display gets progressively more stable. The best advice for the F7 value is to start at 1 and work up until the rate achieves a happy medium between response and steadiness.

The rate zero timeout is the number of seconds between pulses that the ratemeter will wait before making a zero calculation. If the rate smoothing factor is 1, the rate display will go to zero if the time between pulses exceeds the rate zero time. One second is normally a good number for flow applications.

Column d - defaults

Block	Parameter	Range (Default Value is Bold)
d1	Power Up Display	0 Last 1 Total low 2 Rate 3 Batch count 4 Cycle count
d2	Totalizer Display Mode	0 10 digit total 1 Totalizer ÷ 1 2 Totalizer ÷ 10 3 Totalizer ÷ 100
d3	Reset Count Commands	0 No reset 1 Reset totalizer 2 Reset batch count 3 Reset totalizer and batch count 4 Reset cycle count 5 Reset totalizer and cycle count 6 Reset cycle and batch counts 7 Reset totalizer, cycle, and batch counts
d4	Default Commands	0 No default action 1 Default program values 2 Default run values 3 Default program and run values

Depending upon model, options, and programming, there will be anywhere from two to eleven different display screens that the operator can look at in the run mode. When the operator powers this up, what display should he see? Normally it will be the last display he was looking at when he turned power off, in which case the d-1 default setting of 0 is correct. However, the Eclipse can be programmed to always power up to the totalizer display. Batchers have, in addition, the ability to power up to rate, batch count, or cycle count.

PROGRAMMING cont.

Block d2 essentially moves the count decimal point location for the totalizer to the right. This is exactly the opposite of what block F4 does. This can be handy in batchers where the batch count resolution must be in tenths (XXXXX.X), yet the totalizer resolution must be in whole numbers (XXXXXX).

Blocks d3 and d4 are commands. When the enter key is pressed, they do whatever function is associated with the value that was entered, and then the value returns to 0. d3 commands will reset any combination of count registers. d4 can default all program parameters to the factory settings, or default all run mode values (counts and setpoints), or both.

Column L - Control Inputs and Front Panel Keys

Block	Parameter	Range
L1	Control Input 1	S U L R, where S,U,L,&R are
L2	Control Input 2	Start/Stop, Unlatch, Lock, and
L3	Control Input 3	Reset functions from the table on page 30 0000
L4	Front Panel Reset	0 U 0 R, where U & R are Unlatch and Reset Key Functions functions from the table on page 30 0000
L5	Front Panel Start	S U 0 R, where S, U, & R are Start/Stop, Unlatch, and Reset functions from the table on page 30 0000
L6	Front Panel Stop Key Functions	S U 0 0, where S & U are Start/Stop and Unlatch functions from the table on page 30 0000

All totalizers have three control inputs and a front panel reset key. Batchers have both a front panel start key and stop key as well. These inputs perform certain functions necessary in all flow applications. A totalizer without relays has the least number of possible input functions, two. They are lock program and reset total. Use a control input for lock program and either the front panel reset key, or a remote pushbutton or keylock reset switch, or both for reset. The choices for L (Lock) and R (Reset) functions are very limited.

For a totalizer with relays, the number of choices for the Lock function increases, the Reset choice remains the same, and another function category, U (Unlatch) appears. An unlatch input will turn one or both relays OFF if they have been latched ON at a rate or total setpoint. Unlatch functions can be combined with the reset function simply by programming a control input or the reset key to do both. Control inputs programmed to lock may lock out any combination of the program mode, the relay 1 setpoint (P1), and the relay 2 setpoint (P2). Lock inputs cannot be programmed to do any unlatch or reset function, and the front panel reset key cannot be programmed as a lock input.

PROGRAMMING cont.

All totalizers have programming blocks L1 through L4. The default value for each block is 000, which decodes out to be no unlatch (U function), no lock (L function), and no reset (R function). In block L4, the reset key cannot be programmed to do a lock function, so the L value remains at 0, and the edit key skips this category. For totalizers without relays, there are no unlatch functions; therefore the U value remains at 0 and the edit key skips the U category.

Batchers have blocks L1 through L4 plus blocks L5 (start key) and L6 (stop key). In addition to all the input choices available to the totalizer with relays, batchers have more choices for L (Lock) functions and R (Reset) functions, and also have S (Start/Stop) functions. The default value for blocks L1 through L6 is 0000, which decodes out to be no Start/Stop (S function), no unlatch (U function), no lock (L function), and no reset (R function). Control inputs can be programmed to do a lock function or any non-opposing combination of start/stop, unlatch, and reset functions. An example of opposing functions would be Start (which turns ON relay 1), and Unlatch 1 (which turns OFF relay 1). Attempting to program opposing functions will cause the display to read "Lb Err" when the  key is pressed. The front panel reset key cannot be programmed for a start/stop function or for a lock function, so the S and L values in block L4 remain at 0 and the edit key skips these categories. The front panel start key cannot be programmed for a lock function, or for the start/stop function of stop. The front panel stop key cannot be programmed for a lock function or a reset function or start.

The input function selection table is shown below. Pick the appropriate S, U, L, and R values from the table for programming blocks L1 through L6.

Control Input / Key Function Table

Totalizers

<u>U</u>	<u>L</u>	<u>R</u>
0 No Unlatch	0 No Lock	0 No Reset
1 Unlatch 1	1 Lock Pgm	1 Reset Total
2 Unlatch 2	2 Lock Pgm & P1	
3 Unlatch 1&2	3 Lock Pgm & P2	
	4 Lock Pgm, P1, & P2	

1 = Output 1 PGM = Program Mode P2 = Preset 2
 2 = Output 2 P1 = Preset 1

Batch Controls - U functions 0 and 2 above, all L and R functions above, and:

<u>S</u>	<u>U</u>	<u>L</u>	<u>R</u>
0 No Start/Stop		5 Lock Pgm & Cyc	2 Reset Batch
1 Start		6 Lock Pgm, P1, & Cyc	3 Reset Tot & Batch
2 Stop		7 Lock Pgm, P2, & Cyc	4 Reset Cycle
		8 Lock Pgm, P1, P2, & Cyc	5 Reset Tot & Cycle
			6 Reset Batch & Cycle
			7 Reset Tot, Batch & Cycle
			8 Reset Displayed Count

Cyc = Cycle Setpoint

PROGRAMMING cont.

Column r - relays

<u>Block</u>	<u>Parameter</u>	<u>Range</u>
r1	Output 1 Assignment	AM, where A and M are Assignment and Mode choices from the table on page 32. 00 for totalizers 91 for batchers
r2	Output 1 Timeout	0.01 - 99.99 seconds 1.00 for totalizers Latch for batchers
r3	Output 2 Assignment	AM, where A and M are Assignment and Mode choices from the table on page 32. 21 for totalizers 71 for batchers
r4	Output 2 Timeout	0.01 - 99.99 seconds 1.00 for totalizers Latch for batchers

In the batcher, relay 1 is dedicated as the batch final output. It cannot be programmed to do any other function. Relay 2 in the batcher and both relays in the totalizer are indeed programmable. The output assignment (should the output turn ON at a rate or count setpoint, or each time a unit of flow is counted?), and the output mode (should the output turn OFF at a count or rate setpoint or an unlatch input, or after a programmable timeout?) are set in this column.

For a totalizer, there are three events that can occur that can cause an output to turn ON. You get to pick the event as the assignment. The events are when the totalizer count reaches the totalizer preset value (totalizer setpoint), when the displayed rate reaches a high or low (or either) setpoint (rate high, rate low, rate low/high), and when a unit of flow is counted (totalizer scaled pulse out). This may be a good time to mention that if the totalizer is programmed to 10 digit total (block d2 = 0), the totalizer will not have a setpoint, and no output can occur. Once the assignment is determined, the mode must be selected. There are four modes: timed, latched, follows, and pulsed, but only certain modes are appropriate for each assignment. The totalizer setpoint can be timed, in which case the output will turn OFF after a programmed timeout, or latched, in which case the output will turn OFF after an unlatch input occurs. Rate low and rate high assignments can be timed or latched, or can be follows. Follows mode means that the output will turn OFF automatically when the rate goes back above a rate low setpoint, or below a rate high setpoint. The rate low/high assignment is follows only. Rate low/high means that the ratemeter has a low setpoint and a high setpoint; the output is ON when the rate is lower than

PROGRAMMING cont.

the low setpoint or greater than the high setpoint. The output will be OFF whenever the displayed rate is in the window. The totalizer scaled pulse output mode is called pulsed. Pulsed is really a timed mode, but instead of selecting an output time in the range of 0.01 to 99.99 seconds, there are three outputs times from which to choose. Pulsed fast outputs turn OFF after 500 µsec, pulsed medium outputs turn OFF after 2 msec, and pulsed slow outputs turn OFF after 10 msec. If the totalizer is counting faster than it can spit pulses out, it can store up to 9999 counts in a buffer. This is great as a temporary fix; however, if this condition is persistent, pick a faster pulsed output mode.

The batcher only has one programmable output, relay 2. This output can be set to any of the totalizer assignments mentioned above, or to one of two other assignments unique to batchers. The prewarn setpoint output is a latched mode that is used for two valve batch delivery and variations thereof. Prewarn operation is described on page 5. Finally, the assignment can be cycle setpoint. If this is chosen, relay 2 will turn ON when the cycle count equals the cycle preset. Cycle setpoint modes are timed and latched.

Assignment and mode selections are made in programming blocks r1 and r3. If a timed mode is selected in r1, the timeout is entered into block r2. If a timed mode is elected in r3, the timeout is entered into r4.

All assignment and mode (AM) selections for blocks r1 and r3 are listed below. Note that there are two lists: one for a totalizer and one for a batcher. You already know by now which one you have, so pick the right list and make your choice(s).

Totalizer		Output 2 (block r3)	
Output 1 (block r1)		Output 2 (block r3)	
AM		AM	
00	Total Setpoint, Timed	00	Total Setpoint, Timed
01	Total Setpoint, Latched	01	Total Setpoint, Latched
10	Rate Low, Timed	10	Rate Low, Timed
11	Rate Low, Latched	11	Rate Low, Latched
12	Rate Low, Follows	12	Rate Low, Follows
20	Rate High, Timed	20	Rate High, Timed
21	Rate High, Latched	21	Rate High, Latched
22	Rate High, Follows	22	Rate High, Follows
32	Rate High/Low, Follows	32	Rate High/Low, Follows
		43	Total Pulse Out Fast
		53	Total Pulse Out Medium
		63	Total Pulse Out Slow

PROGRAMMING cont.

Batch Control

Output 1 (block r1)	Output 2 (block r3)														
<table border="1" style="border-collapse: collapse; width: 100%;"> <tr> <td style="text-align: center; width: 50px;">AM</td> <td style="border-left: none;"></td> </tr> <tr> <td style="text-align: center;">91</td> <td style="border-left: none;">Batch Final, Latched</td> </tr> </table>	AM		91	Batch Final, Latched	<table border="1" style="border-collapse: collapse; width: 100%;"> <tr> <td style="text-align: center; width: 50px;">AM</td> <td style="border-left: none;"></td> </tr> <tr> <td style="text-align: center;">00-63</td> <td style="border-left: none;">Same choices as Totalizer Output 2, and</td> </tr> <tr> <td style="text-align: center;">71</td> <td style="border-left: none;">Prewarn Setpoint, Latched</td> </tr> <tr> <td style="text-align: center;">80</td> <td style="border-left: none;">Cycle Setpoint, Timed</td> </tr> <tr> <td style="text-align: center;">81</td> <td style="border-left: none;">Cycle Setpoint, Latched</td> </tr> </table>	AM		00-63	Same choices as Totalizer Output 2, and	71	Prewarn Setpoint, Latched	80	Cycle Setpoint, Timed	81	Cycle Setpoint, Latched
AM															
91	Batch Final, Latched														
AM															
00-63	Same choices as Totalizer Output 2, and														
71	Prewarn Setpoint, Latched														
80	Cycle Setpoint, Timed														
81	Cycle Setpoint, Latched														

Column b - Batch Control Functions

<u>Block</u>	<u>Parameter</u>	<u>Range</u>
b1	Batch Counter	0 Reset to Zero (Count Up) 1 Reset to Preset (Count Down)
b2	Hide/Show Overrun	0 Hide overrun 1 Show overrun
b3	Batch Autorecycle	0.1-9. sec. between batches, autorecycle enabled 0.0 Autorecycle disabled.
b4	Cycle Autostop	0 No autostop 1 Batch autostop at cycle setpoint. No cycle count autoreset. 2 Batch autostop at cycle setpoint. Cycle count autoreset

The batch control functions program column b is not in the totalizer unit. Totalizer installers, however, may read this description to see what they're missing. The batch counter will count from zero up to the batch final preset if b1 is set to 0. The batch count then shows gallons delivered. If b1 is set to 1, the batch counter resets to the batch final preset and counts down, showing gallons remaining to be delivered.

At the end of each batch, there may be some overrun due to the flow not stopping precisely when the batch final relay turns OFF, or due to the flowmeter being installed downstream of the valve. The batch counter wants to count the entire amount delivered, including the overrun. If this causes mental anguish with the operator, a value of 0 in block b2 will cause the batch counter to freeze when it reaches the batch final setpoint.

Batch autorecycle is a feature that will not often be used. If the value of b3 is zero, each batch must be started by the operator or by a start input. If b3 is programmed to a time in the range of 0.1 to 9.9 seconds, the batch autorecycle feature is enabled.

PROGRAMMING cont.

This means that once the first batch has been delivered (started by normal means), the batch counter will stop for the timeout period and then automatically reset and start another batch, and another, and another; until the process is stopped by the operator, or by a stop input, or when the cycle counter reaches its setpoint value.

Normally the cycle counter will be used just to count the number of batches that have been delivered. The value of 0 in block b4 covers this function. If the batch counter autorecycle feature is enabled in block b3, the cycle counter will stop the batch counter from autorecycling when the number of batches delivered is equal to the cycle preset by programming a value of 1 into b4. The final variation on the autorecycling theme occurs when b4 is set to 2. This causes the cycle counter to reset itself when the cycle setpoint is reached. Furthermore, if output 2 is programmed as a timed cycle setpoint output (block r3 = 80), the batcher will wait the timeout period and then automatically restart delivery of another cycle setpoint worth of batches. This will continue until the process is stopped by the operator, or by a stop input.

Column C - Communications

<u>Block</u>	<u>Parameter</u>	<u>Range</u>
C1	Serial Address	00 - 99
C2	Baud Rate	0 1200 1 2400 2 4800 3 9600 4 19200
C3	Parity	0 None 1 Odd 2 Even

RS 485 is an industrial communications format that allows multiple units to be connected to a single communication line. Up to 100 units may be on the line, but each must have a unique address entered in block C1.

Each character in the serial command string consists of ten bits. The first bit is a start bit that is followed by seven data bits (ASCII), one parity bit, and finally, one stop bit. The serial protocol used by the Eclipse uses string checksum error detection and does not use parity error detection, but the parity bit must always be sent. The Eclipse will include the parity bit in its response, either as even, odd, or no parity (space).

PROGRAMMING cont.

Column A - Analog Output

<u>Block</u>	<u>Parameter</u>	<u>Range</u>
A1	Assignment	0 Rate 1 Six digit total 2 Batch 3 Cycle
A2	Offset Value	000000-999999
A3	Full Scale Value	000000-999999

The 4-20 mA and 0-10 V analog outputs can be assigned to follow the ratemeter, the totalizer (six digit mode), the cycle counter, or the batch counter. Obviously, the cycle counter and batch counter options are only available in the batch control. The offset value entered in block A2 is the displayed value that causes the analog output to go to its minimum output of 4 mA and 0 V. The full scale value entered in block A3 is the displayed value that causes the analog output to go to its maximum output of 20 mA and 10 V. If a decimal point is programmed for the assigned rate or count display, the decimal point will appear in its proper position in blocks A2 and A3.

RUN MODE

Welcome to the operator's section of this manual. A naive person would believe that this section would be required reading for the person who deals with the counter on a day-to-day basis. In reality, however, about the only time these pages will see the light of day is when the installer is in the checkout phase of the installation. This is o.k. After all, who knows more about the specifics of the application than the installer? Since the information in this section covers all models of the Eclipse flow family and all of the general programming possibilities, the installer is the best person to distill the general information in this section into specific operator instructions that are appropriate to the application. Furthermore, this section only describes the operator functions of the front panel of the counter. What the operator needs to know about the entire system, including external switches wired to the counter, will be specific to the application.

There are five functions that the operator may be expected to do through the front panel of this counter:

1. View count and rate values.
2. Push the reset button.
3. Alternate between two count factors.
4. Change preset values.
5. Start and stop batch delivery.

Viewing Count and Rate Data

There are 14 items that may appear on the display as count or rate data. The number of items depends upon the model and how it is programmed. At least two items will appear on all models (total count and rate), and no Eclipse will show all 14 items under any given programming configuration.

Each item that shows on the display will have two "screens" associated with it. One screen is a title screen that identifies the item. The other screen is the value screen that displays the numeric value for that item. Normally, a value screen showing a number is displayed. The title screen, which identifies an item, appears when the



key is pressed. Title screens are made up of the dreaded 7 segment LED versions of alpha characters. Use the magic decoder ring below to translate the title screen.

Title Screen	Item
	6 digit Totalizer Count
	Low 5 Digits of 10 Digit Totalizer Count
	High 5 Digits of 10 Digit Totalizer Count
	Totalizer Preset
	Rate
	Rate Low Setpoint

RUN MODE cont.



<i>rRt H</i>	Rate High Setpoint
<i>PC</i>	Analog Output Percentage
<i>CFACt</i>	Count Factor Selection
<i>bRtCH</i>	Batch Count
<i>bRt F</i>	Batch Final Preset
<i>bRt P</i>	Batch Prewarn Preset
<i>CYCLE</i>	Cycle Count
<i>CYC P</i>	Cycle Preset

To change which item is displayed,

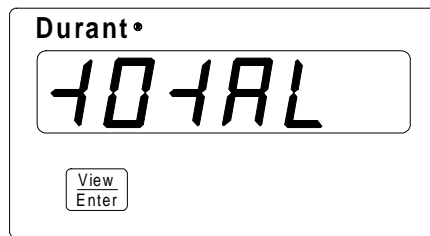
1. Press and hold the  key,



the title screen will appear on the display.

2. While holding , press either the  or  key,



a new title screen will appear on the display each time  or  is pressed.

RUN MODE cont.

3. When the title screen for the desired item is reached, release all keys to display the value for that item.

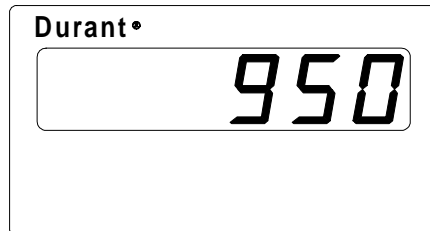

Pushing the Reset Button

The reset key can be programmed to not reset anything, or reset any count register or combination of count registers in the unit. For batchers, resetting is only allowed if the unit is stopped. The reset key may also be programmed to unlatch one or both outputs, or reset count(s) and unlatch output(s). As long as the reset key is programmed to either reset, unlatch, or both, two steps are required:

1. Press the  or  key,

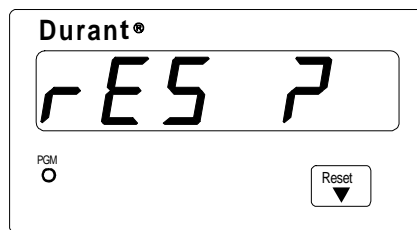

a prompt message will appear on the display and remain there for up to three seconds.

2. Press the  key within three seconds,

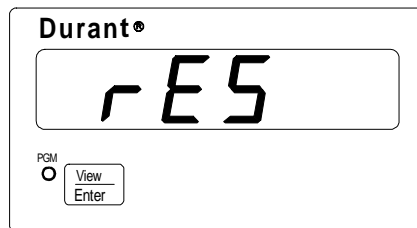

the display will indicate that the reset has been done. After one second, the display will return to whatever item it was showing before the reset key was pressed.

RUN MODE cont.

If the reset key is programmed to do an unlatch function only, the prompt message will be UnL ?, and the acknowledge message will be UnL. If both reset and unlatch functions are programmed, the prompt message will be r-U?, and the acknowledge message will be r-U. If the reset key is programmed to do nothing, or if a batch is running or recycling, pressing the reset key will result in a two-second display of six dashes (-----), which is the counter's way of telling you, "I'll just ignore that, thank you."

Alternate Between Two Count Factors

If CFAcT appears while scrolling through the title screens, the counter is programmed with two pre-loaded count factors and the operator may select the active count factor via the front panel keys. The count factors are shown as CF1 and CF2, and the active count factor appears on the display when the  key is released.

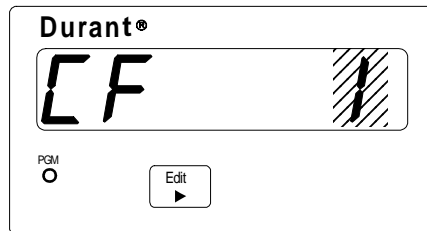

To change from CF1 to CF2, or vice versa,

1. Press the  key,



 Indicates flashing digit.

The "1" will flash.

2. Press the  or ,

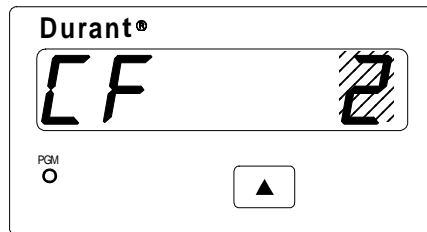

 Indicates flashing digit.

The flashing 1 becomes a flashing 2.

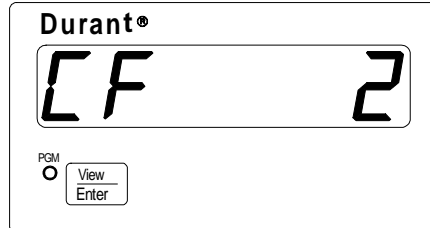

RUN MODE cont.

3. Press the  key,



The flashing stops and count factor 2 is now the active count factor.

Changing a Preset Value

There are six possible presets, also known as setpoints, that can appear on the display. No Eclipse uses more than four of them, and some or all of them may be "locked". If the operator attempts to change a preset value that is locked, the error message **LOC** will appear on the display when the  key is pressed. The title screens for these presets are tot P, rat L, rat H, bat F, bat P, and CYC P. When the  key is released, the present preset value appears on the display.

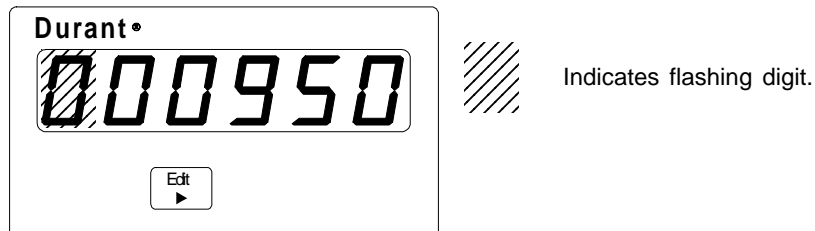

To change the value of a preset or pulses per item (example - change preset 1 from 950 to 870):

1. Press the  key,





the left-most digit (MSD) begins to flash. The preset is edited one digit at a time by selecting a digit (flash) and changing the value of that digit.

RUN MODE cont.

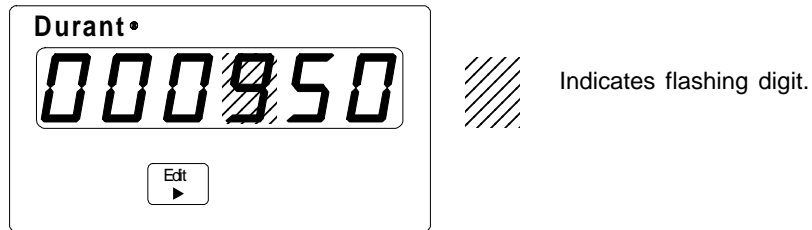
2. Press the  key until a digit that must be changed is flashing. The flash moves one digit to the right each time the  key is poked.



3. Press the  or  key to change the value of the flashing digit.

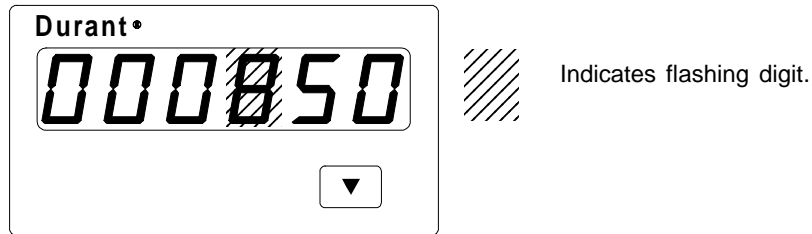

4. Repeat steps 2 and 3 until all digits are changed to the new preset value.

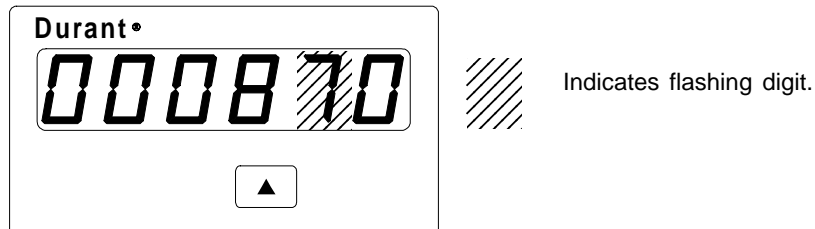

5. Press the  key to enter the new value.

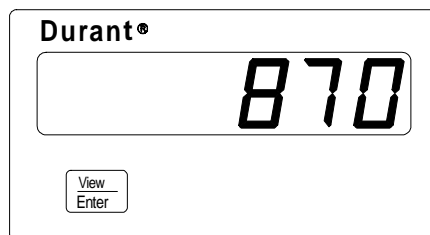

All leading zeros disappear and the flashing stops.

RUN MODE cont.

Starting and Stopping Batch Delivery

This function can only be performed with an Eclipse batch control. Totalizers do not have this capability.

Normally, every batch will be manually started and will stop automatically when the batch is complete. However, conditions may cause the operator to stop the delivery before the batch is complete. If the operator manually stops a batch, he may resume delivery from the point at which he stopped, or may simply terminate the batch.

To start a batch:

1. Enter the batch final preset as shown on page 40.
2. Reset the batch counter as explained in "Pushing the Reset Button." If the batch count value screen is displayed, it will go either to zero or to the batch final preset value.
3. Press the  key,

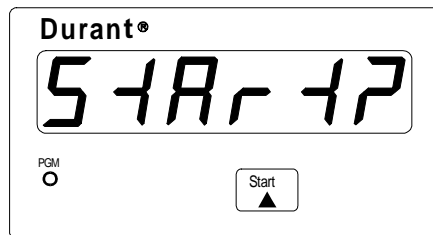

the display will show the start prompt for three seconds.

If the unit has not been reset since the last batch was delivered, one of the following error messages will appear - *CH 00*, or *CH nEG*, or *CH FnL*. Reset the batch count and try again. If the batch final preset has been set to zero, the following error message will appear - *Fn 00*. Enter a batch final preset other than zero and try again.

RUN MODE cont.

4. Press the  key before the start prompt times out,

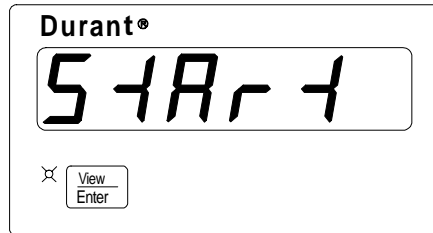

the display will show StArT for two seconds, and the indicating LED will flash.

To stop a batch:

- Press the  key,

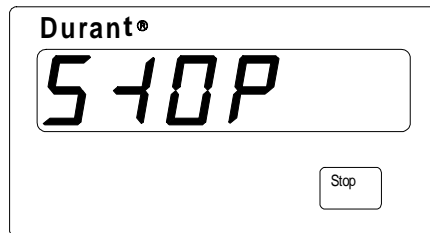

the display will show StOP for two seconds, and the indicating LED will turn OFF.

To resume a batch that has been stopped,

1. Press the  key,

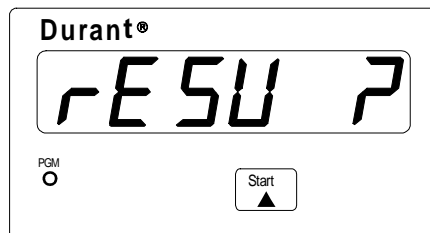

the display will show the resume prompt for three seconds.

RUN MODE cont.

2. Press the  key before the start prompt times out,

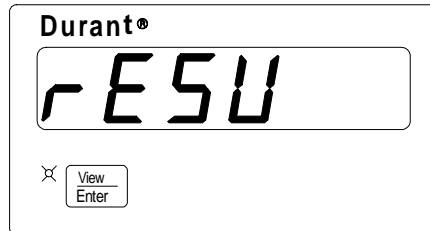

the display will show rESU (resume) for two seconds, and the indicating LED will flash.

To terminate a batch that has been stopped, simply reset the batch counter with the reset key.

Variations of starting and stopping are possible due to external inputs and programming. However, the method described above should be fairly common.

If the Eclipse has been programmed to autorecycle; that is, to deliver a batch, then wait for a timeout period and start another batch, the message *rECY* will appear briefly on the display each time a new batch is started. If the cycle setpoint is used to stop delivery after a preset number of batches has been delivered, the message *nrECY* will appear on the display after the number of batches is completed.

DIAGNOSTICS and ERROR MESSAGES

This section of the manual deals with the unexpected. Normally the installer or operator will not come to these pages because the installation is working just fine. However, there may come a time when you get that feeling that the Eclipse is trying to tell you something by putting up an error message on the display, or you may feel that an input key or an output is not doing what it is supposed to do. These unexpected events are what this section is all about.

Power Up Diagnostics

Each time power is applied to the Eclipse, it runs a series of memory tests. While these tests are being run, a lamp test is done on the display. The lamp test consists of all display segments being ON for 1 to 2 seconds.

After the lamp test, any diagnostic test failure will be indicated by an error message. If one of the following occurs,

Err 1
Err 2
Err 3

an internal RAM, ROM, or EEPROM memory device has failed and the unit should be returned to the factory for repair. These errors are not recoverable.

Additionally, four memory checksum tests are performed. A failure in any of these tests will result in an error message on the display. These errors are recoverable, however, program selections or calibration data or run data will be lost. A checksum test failure indicates that the stored data does not match the stored checksum of the data; therefore the data is invalid. The recovery process loads default data into the affected memory area. The user acknowledges the error message by pressing any key on the keypad. The Eclipse responds with an appropriate default message indicating which section of memory has been defaulted. The user should then re-enter program values or presets before operating the unit. In the case of a calibration error, which applies only to the analog output option, the unit should be recalibrated before being put back into service.

The four checksum test error messages are:

- Er CAL* Calibration error. This applies only to the calibration of the analog output option. Press any key to clear the message. The display will respond with *dF CAL*. Re-calibrate the analog output before putting the unit back in service.
- Er PrG* Program data error. Press any key to clear the message. The display will respond with *dF PrG*. Re-enter the program mode selections for your application before putting the unit back in service.
- Er run* Run data error in EEPROM or NOVRAM.

DIAGNOSTICS and ERROR MESSAGES

Er run Press any key to clear the message. The display will respond with **dF rUn**. Re-enter preset values and count factors before putting unit back in service.

There is one more error message that may occur at any time. The Eclipse has an internal watchdog timer that must be reset every second. If the unit is busy handling high priority tasks, such as counting input pulses above the maximum count input speed, or if electrical noise disrupts the microprocessor, the watchdog timer may time out and the display will show:

Er doG Watchdog timeout. Press any key to acknowledge and return the display to normal. Nothing will be defaulted, however, the user should check all run and program data to insure that nothing was corrupted.

Run Mode Five (5) Second Messages

A number of messages may appear on the run mode display every five seconds. These messages indicate that a programming error has been made, or that the count inhibit input is active, or an overflow condition occurred. In some cases, the message can be cleared by entering a setpoint. In other cases, the user must correct a change made in the program mode.

The messages and descriptions are:

Ro Er Analog output span error. The analog output offset value is greater than the full scale value.

PUL OF Pulse overflow. The totalizer scaled pulse output buffer has exceeded 9,999 counts.

PUL Er Pulse error. The count factor causes more than 9,999 counts to enter the scaled pulse output buffer for each count pulse in.

b-3 Er Error in programming block b-3. Autocycle is disabled in block b-3, but Autostop is selected in block b-4.

LR Err Error in programming column L. An input has been programmed for Start, but no input is programmed for Stop.

Lb Err Error in programming Column L. Opposing functions programmed. Output 2 is programmed for batch prewarn and an input is programmed to unlatch output 2.

tot 00 Totalizer setpoint is set to zero and an output is programmed for totalizer setpoint.

CI inh Count inhibit input is active.

OUT Er Output error. An output is programmed for totalizer setpoint and the totalizer is programmed to 10 digit total.

rRt Er Rate error. The rate low setpoint is greater than the rate high setpoint.

DIAGNOSTICS cont.

Keyboard Diagnostic Mode

The keyboard diagnostics allows the user to test each of the front panel keys, the display, and the analog and relay outputs if present in the unit.





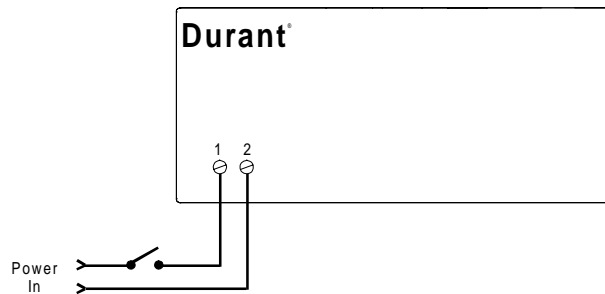

Caution: performing the keyboard diagnostic tests will turn ON the analog and relay outputs if they are installed in the unit. Remove power from the counter and disconnect any output that should not activate its load during the diagnostic tests.

To enter the keyboard diagnostic mode,

1. Turn power to the unit OFF.





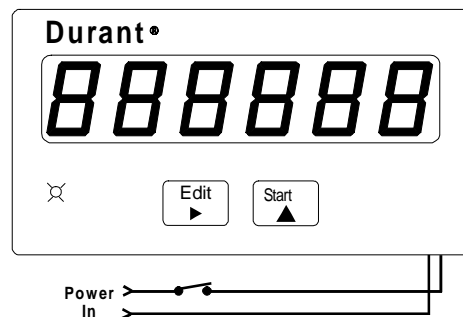

2. If any control input is programmed to a lock function, remove the jumper wire from that input to ground.
3. While holding down both the  and  keys, turn unit power ON. After 1.5 seconds, the unit will be in the diagnostic mode. Release the  and  keys at this time. All LED segments and the program LED will be ON. If present, both relays will be OFF, and the analog output will be at minimum values (4 mA and 0V).



DIAGNOSTICS cont. / SPECIFICATIONS

There are four keyboard diagnostic tests, one for each key. The tests are performed by pressing each key. The unit's response is maintained as long as the key is held.

Test Key		Unit Response
View/Enter		Display shows software revision number
Edit/Right Arrow		All display segments and the program LED will turn OFF, and the analog output will go to maximum values (20 mA and 10V).
Up Arrow		Each display digit will turn ON, one at a time, and relay 2 will turn ON.
Down Arrow		Each display segment of all digits will turn ON, one segment at a time, and relay 1 will turn ON.

To exit the keyboard diagnostic mode, turn unit power off.

SPECIFICATIONS

MECHANICAL

Cutout Dimensions: 3.62" W x 1.77" H (92mm x 45mm) DIN standard
Outline Dimensions: 4.04" W x 2.19" H x 3.87" D (103mm x 56mm x 98mm)
3.60" (92mm) maximum depth in panel
Enclosure: Plastic with polyester front label
Connectors: Up to six de-pluggable terminal blocks

INPUT POWER

AC Powered Models (57751-4XX)
Input Power: 85-265 VAC, 47-63 Hz, 20 VA
External Fuse: 0.2A, 250 VAC, Time Delay (T200mA, 250V)
Isolation Dielectric Strength: 2300 VAC

DC Powered Models (57750-4XX)
Input Power: 9-30 VDC, 12 VA
External Fuse: 2.0A, 50 VDC, Time Delay (T2A, 50V)
Reverse Voltage Protection: Yes
Isolation Dielectric Strength: 2300 VAC to signal inputs and relays, 500 VAC to RS 485 and analog outputs

HUMAN INTERFACE

Display: 6 digits
Type: .56" high, seven segment, red LED

SPECIFICATIONS cont.

DATA RETENTION

Memory Type: EEPROM, no batteries required
Duration: 100 years

COUNT SIGNAL INPUT / COUNT INHIBIT SIGNAL INPUT

Sensor Type: Sink or source, DIP switch selectable
Input Impedance: 4.75 k ohms to +5 VDC or 34.9 k Ohms to ground
Thresholds: High 3.5 to 28 VDC, low 0 to 1.9 VDC, for single ended signals
Magnetic Pickup Range: 50 mV p-p to 65 VRMS into 34.9 k Ohms
Slow Response: 50 Hz max. (DIP switch 2 and/or 5 ON)
Fast Response: 10 kHz

CONTROL INPUTS

Sensor Type: Sink only
Input Impedance: 4.75 k ohms to +5 VDC
Thresholds: High 3.5 to 28 VDC, low 0 to 1.0 VDC
Response: 25 msec maximum (5V signal)

ACCESSORY POWER OUTPUT

Voltage: 12 VDC +/- 12%
Current: 75 mA max.
Protection: Short circuit protected

RELAY / TRANSISTOR OUTPUTS (standard on batch controls, optional on totalizers)

Number:	2 relays or 1 relay and 1 transistor
Relay Contact Type:	1 set form C per relay
Relay Contact Rating:	5A, 250 VAC or 30 VDC
Transistor Type:	NPN, Opto Isolated
OFF State Block:	30 VDC max., 0.1 mA max. leakage current
ON State Conduct:	50 mA max., 1.2 VDC max. C-E drop
Max. Switching Frequency:	4 kHz (50-50 duty cycle)
Isolation dielectric strength:	2300 VAC

SPECIFICATIONS cont.

OPTIONAL OUTPUTS

Analog Retransmission

Output signals: 4-20 mA (<750 Ω) and 0-10 V (>2500 Ω)
Accuracy: 0.13% full scale and 100 PPM /°C (and 0.07% full scale change over 4-20 mA load ranges)
Isolation dielectric strength: 2300 VAC to signal inputs, relays, and AC power inputs, 500 VAC to analog outputs and DC power inputs

RS 485 Serial Communications

Baud Rate: 1200, 2400, 4800, 9600, or 19,200, programmable
Parity: Even, odd, or no parity
Address Range: 00 to 99 decimal (00 indicates offline)
Protocol: Opto 22[®] compatible
Isolation Dielectric Strength: 2300 VAC to signal inputs, relays, and AC power inputs, 500 VAC to analog outputs and DC power inputs

ENVIRONMENTAL

Operating Environment: Indoor use to 2000 meters
Temperature: Operating: 0 to 50°C
Storage: -20 to 70°C
Humidity: 0 to 85% RH, non-condensing
Vibration: 2.5 g's, 30 to 200 Hz
Shock: 30 g's, 11 msec half sinewave
EMC: Immunity to EN 50082-2 (Heavy Industrial)
Emissions to EN 50081-2 (Heavy Industrial)
Front Panel: NEMA 4X when mounted with gasket provided
Agency Approval: UL, cUL listed, CE marked
CE EMC immunity and emissions requirements were met using shielded wiring on the RS-485, analog output, and pulse input/power lines. The shields were connected to earth ground at the Eclipse end of the shields.
Pollution Degree 2 Overvoltage category II

WARRANTY

Eaton warrants all products against defects in material and workmanship for a period of one (1) year from the date of shipment to Buyer. This is a limited warranty limited to its terms. This warranty is void if the product has been altered, misused, taken apart or otherwise abused. **ALL OTHER WARRANTIES, EXPRESS OR IMPLIED, ARE EXCLUDED, INCLUDING BUT NOT LIMITED TO THE IMPLIED WARRANTIES OF MERCHANTABILITY AND FITNESS FOR PURPOSE.**

BUYERS REMEDIES: Eaton's obligations and liabilities under the foregoing warranty are limited to repair or replacement of the product without charge. To receive the required Return Goods Authorization number (RGA), contact your local Durant distributor or call 1-800-540-9242 to get a list of distributors in your area. A charge is made for repairing after the expiration of the warranty. **IN NO EVENT SHALL EATON BE LIABLE FOR CLAIMS BASED UPON BREACH OF EXPRESS OR IMPLIED WARRANTY OR NEGLIGENCE OR ANY OTHER DAMAGES WHETHER DIRECT, IMMEDIATE, FORESEEABLE, CONSEQUENTIAL OR SPECIAL OR FOR ANY EXPENSES INCURRED BY REASON OF THE USE OR MISUSE, SALE OR FABRICATION OF PRODUCTS WHICH DO OR DO NOT CONFORM TO THE TERMS AND CONDITIONS OF THIS CONTRACT.**

INDEMNIFICATION: Buyer agrees to hold Eaton harmless from, defend, and indemnify Eaton against damages, claims and expenses arising out of subsequent sales of Durant products or products containing components manufactured by Eaton and based upon personal injuries, deaths, property damage, lost profits, and other matters for which Buyer, its employees or sub-contractors are or may be to any extent liable, including without limitation penalties imposed by the Consumer Product Safety Act (P.L.92-573) and liability imposed upon any person pursuant to the Magnuson-Moss Warranty Act (P.L.93.637), as now in effect or as amended hereafter. The warranties and remedies provided for herein are available to Buyer and shall not extend to any other person.

COMPLIANCE WITH OSHA: Eaton offers no warranty and makes no representation that its products comply with the provisions or standards of the Occupational Safety and Health Act of 1970, or any regulations issued thereunder. In no event shall Eaton be liable for any loss, damages, fines, penalty or expense arising under said ACT.

This manual constitutes proprietary information of Eaton Corp., and is furnished for the customers' use in operating the Durant control. Reproduction of this material for purposes other than the support of Durant counters or related products is prohibited without the prior written consent of Eaton Corp., Watertown, WI.

In the construction of the control described herein, the full intent of the specifications will be met. Eaton Corp., however reserves the right to make, from time to time and without proper written notice, such departures from the detail specifications as may be required to permit improvements in the design of the product.

The information included herein is believed to be accurate and reliable; however no responsibility is assumed by Eaton Corp., for its use; nor for any infringements of patents or other rights of third parties which may result from its use.

This equipment is capable of generating radio frequency energy. If not installed and used in accordance with the instructions, this unit may interfere with radio communications.

Durant
901 S. 12th Street
Watertown, WI 53094
800-540-9242 • 920-261-4070
Fax: 920-261-9097
www.durant.com

Eclipse Series Pulse Input

Flow Totalizers

Flow Ratemeters

Flow Batch Controls

Models: 5775X-40X - Totalizer w/Rate
5775X-41X - Batch Control

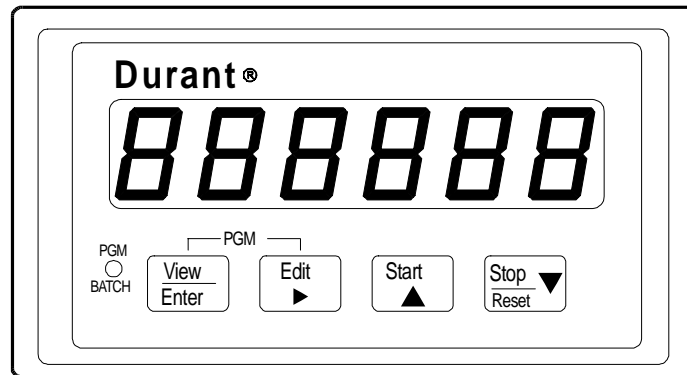

Table of Contents

1	Introduction	36	Run Mode
1	Description	45	Diagnostics and Error Messages
10	Mounting		
11	Wiring	48	Specifications
21	Programming		

Durant®

Visit our Web Site at
www.durant.com

