

Model GMSG1 - Graphite® Strain Gage Module



- STRAIN GAGE MODULE FOR THE GRAPHITE PRODUCTS
- PID CONTROL WITH REDUCED OVERSHOOT
- LOAD CELL, PRESSURE AND TORQUE BRIDGE INPUTS
- SELECTABLE LOW LEVEL INPUTS (20 mV, 33 mV or 200 mV FULL SCALE)
- SOFTWARE SELECTABLE 5 VDC or 10 VDC BRIDGE EXCITATION
- DIGITAL TARE (re-zero), BATCH TOTALIZER, AND PEAK/VALLEY (max/min) RECORDING
- ON DEMAND AUTO-TUNING OF PID SETTINGS
- DC ANALOG OUTPUT
- CONFIGURED USING CRIMSON® SOFTWARE (VERSION 3.0 OR LATER)



FOR USE IN HAZARDOUS LOCATIONS:
 Class I, Division 2, Groups A, B, C, and D
 T4

For Model No. GMSG10S0 and GMSG11S0 Only



II 3 G Ex nA IIC T4 Gc
 -40°C ≤ T_{AMB} ≤ 75°C
 DEMKO 14 ATEX 1387X
 IECEx UL 15.0035X



For Model No. GMSG10S0 and GMSG11S0 Only

GENERAL DESCRIPTION

The Model GMSG is a full featured single loop PID controller designed for use with the Graphite products. The module accepts low level signals from a variety of bridge-type transducers, such as load cells, pressure transducers, torque transducers, etc. An optional second signal input is available, providing math capabilities between the two input channels (average, differential, etc.). Each input channel provides a software selectable 5 V or 10 V stable bridge excitation voltage, capable of driving up to four 350 W bridges (combined total per module). The inputs are selectable for ±20 mV, ±33 mV, or ±200 mV full scale. With solid state or relay outputs, plus an analog output, the GMSG module can perform virtually any combination of time-proportioning or linear control. The discrete outputs may also be assigned to one of seven internal soft alarms; and the linear output can be assigned to transmit virtually any internal variable. In addition, digital tare (re-zero), batch totalizer, and peak/valley (max/min) are provided.

The modules connect and communicate via proprietary USB connection to the various Graphite host devices. Those devices, equipped with serial ports as well as Ethernet port(s), allows the system to share data with PCs, PLCs, and SCADA systems.

Caution should be used when adding modules to Graphite. Some modules, depending on usage, may consume high levels of power. This may limit the total number of modules that can be installed on a single Graphite host. Check the Graphite module and Graphite host data sheets for specific usage and power requirements.

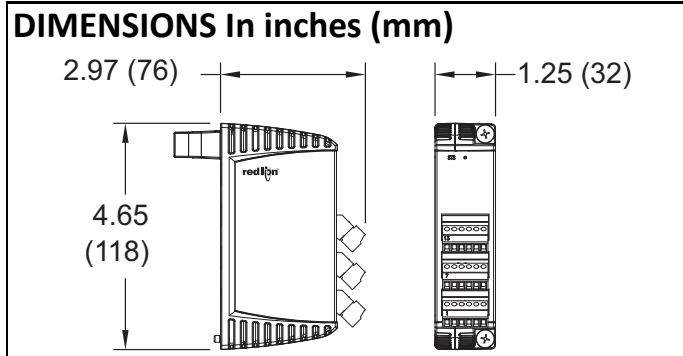

The GMSG modules are available with relays, or open drain MOSFET outputs. For applications requiring large loads to be controlled, several DIN rail mount relays are available.

The modules can operate in On/Off, P, PI, or PID control mode, and use an on-demand Auto-Tune that establishes the tuning constants. The PID constants may be fine-tuned through the serial or Ethernet interface. The modules employ a unique overshoot suppression feature, which allows the quickest response without excessive overshoot. The modules can also be operated in manual mode, providing the operator with direct control of the output.

CONFIGURATION

The Graphite® is configured with Windows® compatible Crimson® software. The software is an easy to use, graphical interface which provides a means of configuration and commissioning of new systems, as well as routine module re-calibration.

SAFETY SUMMARY

All safety related regulations, local codes and instructions that appear in this literature or on equipment must be observed to ensure personal safety and to prevent damage to either the instrument or equipment connected to it. If equipment is used in a manner not specified by the manufacturer, the protection provided by the equipment may be impaired.

Do not use this unit to directly command motors, valves, or other actuators not equipped with safeguards. To do so can be potentially harmful to persons or equipment in the event of a fault to the unit.



CAUTION: Risk of Danger.

Read complete instructions prior to installation and operation of the unit.



WARNING - EXPLOSION HAZARD - DO NOT DISCONNECT EQUIPMENT UNLESS POWER HAS BEEN SWITCHED OFF OR AREA IS KNOWN TO BE NON-HAZARDOUS.



WARNING - EXPLOSION HAZARD - SUBSTITUTION OF COMPONENTS MAY IMPAIR SUITABILITY FOR CLASS I, DIVISION 2.

SPECIFICATIONS

1. **POWER:** Power will be supplied by the Graphite host device. Some modules, depending on usage may consume high levels of power. This may limit the total number of modules that can be installed on a single Graphite host. Check the Graphite module and Graphite host data sheets for specific usage and power requirements.

GMSG1 Max Power: 5.6 W

2. LEDs*:

STS - Status LED shows module condition.
 OP1, OP2, OP3 - Indicate status of outputs 1, 2, and 3
 ALM - Alarm LED is lit during any internal alarm condition.
 * Default configuration.

3. **MEMORY:** Non-volatile memory retains all programmable parameters.

4. INPUTS:

SELECTABLE INPUT RANGE	ACCURACY * 18 TO 28 °C 10 TO 75% RH	ACCURACY * 0 TO 50 °C 0 TO 85% RH	ACCURACY * -40 TO 70 °C 0 TO 85% RH
±20.000 mVDC	0.02% of reading +3 µV	0.07% of reading +4 µV	0.09% of reading +5 µV
±33.000 mVDC	0.02% of reading +5 µV	0.07% of reading +7 µV	0.09% of reading +9 µV
±200.00 mVDC	0.02% of reading +30 µV	0.07% of reading +40 µV	0.09% of reading +50 µV

* After 20 minute warm-up. Accuracy includes the temperature coefficient.

Connection Type:

- 4-wire bridge (differential)
- 2-wire (single-ended)

Sample Time: 50 msec (20 readings per second)

Common Mode Range (with respect to input common): 0 to +5 VDC

Common Mode Rejection: > 100 dB, DC to 120 Hz

Temperature Coefficient (ratio metric): 20 ppm/°C max.

Step Response Time: 200 msec max. to within 99% of final process value

Input Impedance: 100 MΩ

Max Continuous Overload: 30 V

PV Range: -30,000 to 30,000

Effective Resolution: 16-bit

5. BRIDGE EXCITATIONS:

Software selectable:

- 5 VDC, ±2%, 65 mA max.
- 10 VDC, ±2%, 125 mA max. combined (excitation 1 plus excitation 2).

Temperature coefficient (ratio metric): 20 ppm/°C max.

Max. four 350 Ω bridges per module.

6. **ISOLATION LEVEL:** 500 Vrms @ 50/60 Hz for 1 minute between the following:

OP1 * OP2 * OP3 *

Linear Output

Signal Inputs (the 2 input channels are not isolated from each other)

Power Supply Input

* Outputs OP1, OP2 and OP3 of SSR model are not isolated from each other

7. **COMMUNICATIONS:** Provided by the Graphite host device.

8. DISCRETE OUTPUTS:

Available as (3) Solid State NFET, or (3) Form A relay.

Solid State Output:

- Type: Switched DC, N Channel open drain MOSFET
- Current Rating: 1 A max
- VDS ON: 0.3 V @ 1 A
- VDS MAX: 30 VDC
- Offstate Leakage Current: 0.5 mA max

Form A Relay Output:

- Type: N.O.
- Current Rating: 3 Amps @ 125 VAC
- 1/10 HP @ 125 VAC
- Life Expectancy: 200,000 cycles at maximum load rating.
 (Decreasing load, increasing cycle time, and use of surge suppression such as RC snubbers increases life expectancy.)

9. CONTROL MODES:

Control: On/Off, P, PI, or PID

Output: Time proportioning or linear

Cycle Time: Programmable from 0.0 to 60.0 sec

Auto-Tune: When selected, sets proportional band, integral time, derivative time values, and output dampening time

Input Fault Response: Upscale

10. ALARMS:

Modes: Manual

- Absolute High Acting
- Deviation High Acting
- Inside Band Acting
- Absolute Low Acting
- Deviation Low Acting
- Outside Band Acting

Reset Action: Programmable; automatic or latched

Standby Mode: Programmable; enable or disable

Hysteresis: Programmable

Input Fault Response: Upscale

11. ANALOG DC OUTPUT:

Software programmable for 0-10 VDC, 0-20 mA, or 4-20 mA

Resolution:

Voltage: 500 µV

Current: 1 µA

Accuracy:

- 0.1% of full scale (18 to 28 °C)
- 0.2% of full scale (-40 to 70 °C)

Update Time: 0.0 to 60.0 sec

Compliance (for current output only): 500 Ω max.

Minimum load (voltage output only): 10 KΩ min.

Output is software selectable for either 10 V or 20 mA. The output range may be field calibrated to yield approximate 10% overrange and a small underrange (negative) signal.

12. ENVIRONMENTAL CONDITIONS:

Operating Temperature Range:

- GMSG10R0 and GMSG11R0: -40 to 70 °C
- GMSG10S0 and GMSG11S0: -40 to 75 °C

Operating temperature is limited to lowest range among equipment used in your Graphite system. Consult the user manual or www.redlion.net/OpTemp for further details.

Storage Temperature Range: -40 to +85 °C

Shock to IEC 68-2-27: Operational 40 g (10 g, relay).

Operating and Storage Humidity: 85% max. relative humidity, non-condensing.

Altitude: Up to 2000 meters

13. CERTIFICATIONS AND COMPLIANCES:

CE Approved

- EN 61326-1 Immunity to Industrial Locations
- IEC/EN 61010-1
- RoHS Compliant

ATEX Approved (GMSG10S0 and GMSG11S0 only)

- Ⓜ II 3 G Ex nA IIC T4 Gc
- DEMKO 14 ATEX 1387X
- EN 60079-0, -15

IECEx Approved (GMSG10S0 and GMSG11S0 only)

- Ex nA IIC T4 Gc
- IECEx UL 15.0035X
- IEC 60079-0, -15

UL Listed: File #E302106

UL Hazardous: File #E317425 (GMSG10S0 and GMSG11S0 only)

ABS Type Approval for Shipboard Applications

14. **CONSTRUCTION:** Case body is all metal construction.

15. **CONNECTIONS:** Removable wire clamp screw terminal blocks

Wire Gage: 28-16 AWG (0.32 mm - 1.29 mm) terminal gage wire

Torque: 1.95-2.21 inch-lbs (0.22-0.25 N-m)

16. **MOUNTING:** Screws to host

17. **WEIGHT:** 8 oz (224 g)

EMC INSTALLATION GUIDELINES

Although Red Lion Controls products are designed with a high degree of immunity to Electromagnetic Interference (EMI), proper installation and wiring methods must be followed to ensure compatibility in each application. The type of the electrical noise, source or coupling method into a unit may be different for various installations. Cable length, routing, and shield termination are very important and can mean the difference between a successful or troublesome installation. Listed are some EMI guidelines for a successful installation in an industrial environment.

1. A unit should be mounted in a metal enclosure, which is properly connected to protective earth.
2. Use shielded cables for all Signal and Control inputs. The shield connection should be made as short as possible. The connection point for the shield depends somewhat upon the application. Listed below are the recommended methods of connecting the shield, in order of their effectiveness.
 - a. Connect the shield to earth ground (protective earth) at one end where the unit is mounted.
 - b. Connect the shield to earth ground at both ends of the cable, usually when the noise source frequency is over 1 MHz.
3. Never run Signal or Control cables in the same conduit or raceway with AC power lines, conductors, feeding motors, solenoids, SCR controls, and heaters, etc. The cables should be run through metal conduit that is properly grounded. This is especially useful in applications where cable runs are long and portable two-way radios are used in close proximity or if the installation is near a commercial radio transmitter. Also, Signal or Control cables within an enclosure should be routed as far away as possible from contactors, control relays, transformers, and other noisy components.
4. Long cable runs are more susceptible to EMI pickup than short cable runs.
5. In extremely high EMI environments, the use of external EMI suppression devices such as Ferrite Suppression Cores for signal and

control cables is effective. The following EMI suppression devices (or equivalent) are recommended:

Fair-Rite part number 0443167251 (Red Lion Controls #FCOR0000)

Line Filters for input power cables:

Schaffner # FN2010-1/07 (Red Lion Controls #LFIL0000)

6. To protect relay contacts that control inductive loads and to minimize radiated and conducted noise (EMI), some type of contact protection network is normally installed across the load, the contacts or both. The most effective location is across the load.
 - a. Using a snubber, which is a resistor-capacitor (RC) network or metal oxide varistor (MOV) across an AC inductive load is very effective at reducing EMI and increasing relay contact life.
 - b. If a DC inductive load (such as a DC relay coil) is controlled by a transistor switch, care must be taken not to exceed the breakdown voltage of the transistor when the load is switched. One of the most effective ways is to place a diode across the inductive load. Most Red Lion products with solid state outputs have internal zener diode protection. However external diode protection at the load is always a good design practice to limit EMI. Although the use of a snubber or varistor could be used.
Red Lion part numbers: Snubber: SNUB0000
Varistor: ILS11500 or ILS23000
7. Care should be taken when connecting input and output devices to the instrument. When a separate input and output common is provided, they should not be mixed. Therefore a sensor common should NOT be connected to an output common. This would cause EMI on the sensitive input common, which could affect the instrument's operation.

Visit www.redlion.net/emi for more information on EMI guidelines, Safety and CE issues as they relate to Red Lion products.

Block Diagram for GMSG1

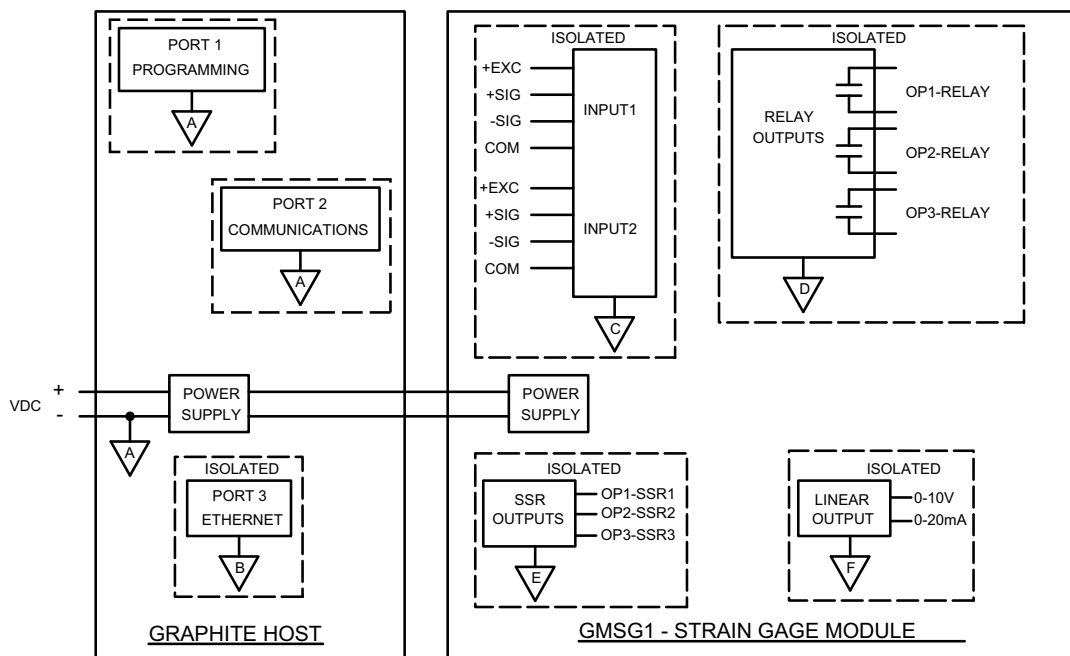

HARDWARE

INPUT RANGE SELECTION

Select either ± 20 mV or the ± 33 mV | ± 200 mV range by placing the input jumper in the appropriate location. The input jumpers are located on the side of the GMSG1 module.

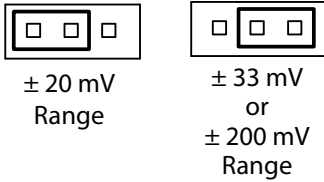

HARDWARE INSTALLATION

The physical order of all installed modules must match the modules order in Crimson. Torque screws to 6.0 pound-force inch [96 ounce-force inch] (0.68 Nm).

CAUTION: Some modules, depending on usage, may consume high levels of power. This may limit the total number of modules that can be installed on a single Graphite host. Check the Graphite module and Graphite host data sheets for specific usage and power requirements.

WARNING: Disconnect all power to the unit before installing or removing modules.

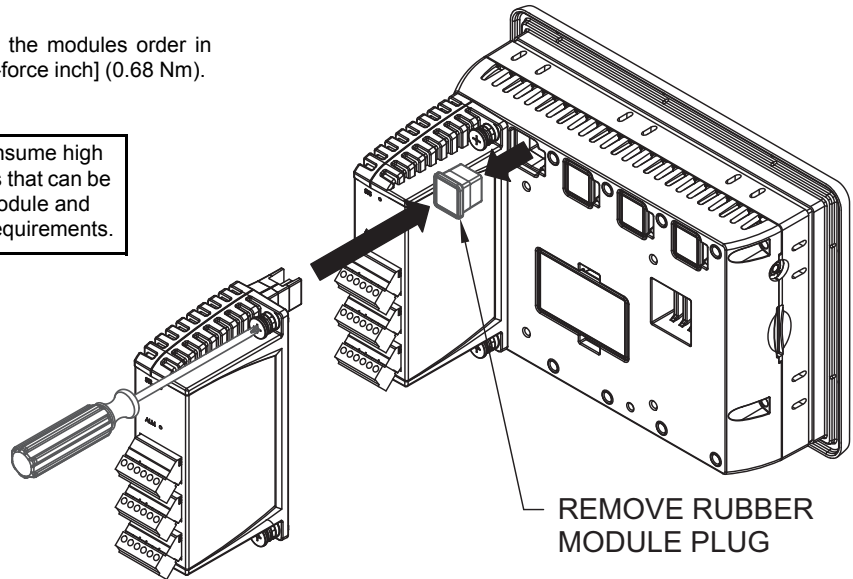

REMOVE RUBBER MODULE PLUG

WIRING

WIRING CONNECTIONS

All conductors should meet voltage and current ratings for each terminal. Also, cabling should conform to appropriate standards of good installation, local codes and regulations and be suitably rated for the temperatures of the environment to which it is being installed. When wiring the module, use the numbers on the label to identify the position number with the proper function. Strip the wire, leaving approximately 1/4" (6 mm) of bare wire exposed. Insert the wire into the terminal, and tighten.

WARNING - EXPLOSION HAZARD - DO NOT CONNECT OR DISCONNECT CABLES WHILE POWER IS APPLIED UNLESS AREA IS KNOWN TO BE NON-HAZARDOUS.

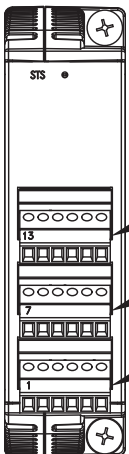

Terminals 13 to 18

Terminals 7 to 12

Terminals 1 to 6

OP3 COM.	OP3 +	N/C	N/C	ANALOG+	ANALOG-
13	14	15	16	17	18

OP1 COM.	OP1 +	OP2 COM.	OP2 +	+SIG.	+EXC
7	8	9	10	11	12

COM.	-SIG.	+SIG.	+EXC	COM.	-SIG.
1	2	3	4	5	6

INPUT CONNECTIONS

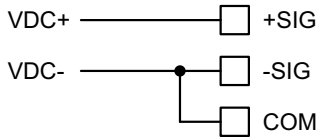

2-Wire Single Ended Input

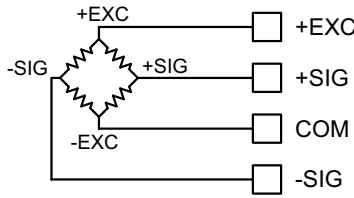

4-Wire Bridge Input

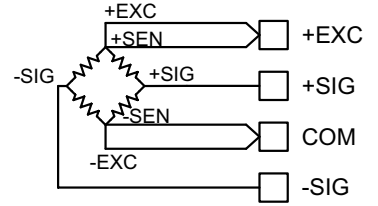

6-Wire Bridge Input

BRIDGE COMPLETION RESISTORS

For single strain gage applications, bridge completion resistors must be employed externally to the module. Only use metal film resistors with a low temperature coefficient of resistance.

Load cells and pressure transducers are normally implemented as full resistance bridges and do not require bridge completion resistors.

OUTPUT CONNECTIONS (3 Form A relays or 3 SSR; Each model has analog output)

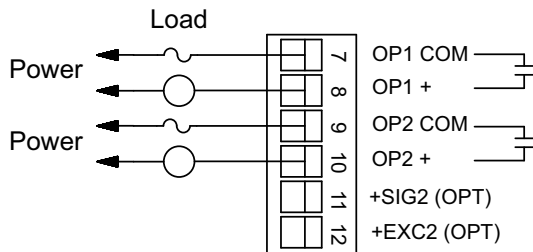

Outputs 1 and 2 - Relay Version

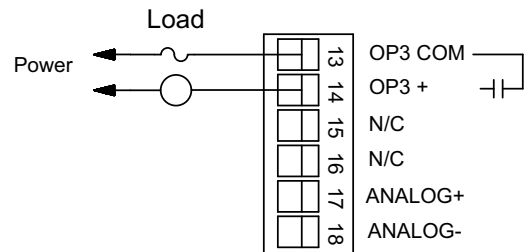

Output 3 - Relay Version

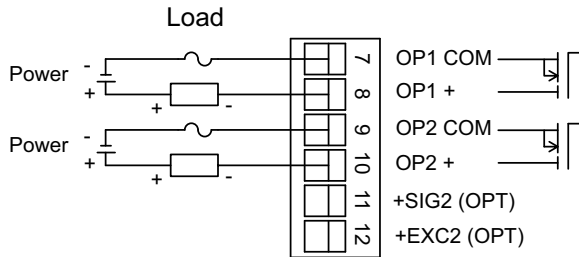

Outputs 1 and 2 - Solid State Version

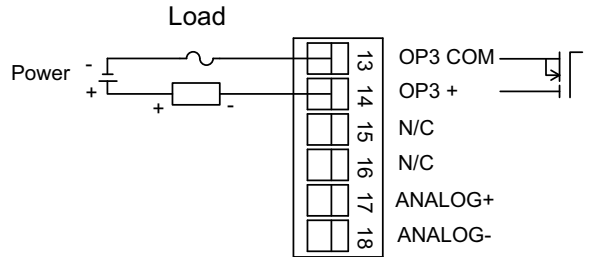

Outputs 3 - Solid State Version

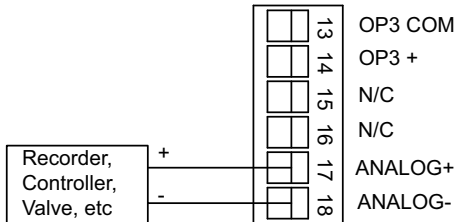

Analog Output

LEDs

STS – STATUS LED

The Status LED is a green LED that provides information regarding the state of the module. This includes indication of the various stages of the start-up routine (power-up), as well as any errors that may occur.

Startup Routine

Off	Module is currently running the boot loader and/or being flash upgraded by Crimson.
Flashing Green	Module switching to configuration.
Green	Module performing normally.

Error States

Flashing Green	Module is controlling properly, but has lost communication with the Host.
----------------	---

OP1, OP2, OP3, – Output Status LED

The OP1, OP2, and OP3 LEDs are factory configured to indicate the status of the outputs. The LEDs turn on when the output is active.

These LEDs may be remapped to various other module properties.

ALM – ALARM LED

The Alarm LED is factory configured to indicate the presence of an alarm. Whenever one of the seven alarms is active, the LED turns on.

This LED may be remapped to various other module properties.

FIRMWARE UPGRADE

The module's firmware is stored in flash memory so that software/hardware conflicts are avoided, and so features can be added in the future.

During a download, Crimson compares its own library of firmware files with those stored in the module. If they do not match, Crimson will download the necessary firmware.

CONFIGURATION

Programming is done via Crimson® software, a Windows® compatible configuration interface. Please see the Crimson manual for more information.

GRAPHITE TROUBLESHOOTING

If for any reason you have trouble operating, connecting, or simply have questions concerning your new Graphite unit, contact Red Lion's technical support.

Email: support@redlion.net

Website: www.redlion.net

Inside US: +1 (877) 432-9908

Outside US: +1 (717) 767-6511

ORDERING INFORMATION

TYPE	DESCRIPTION	PART NUMBER
Input Modules	Graphite Module, Single Loop, One Strain Gage Input, Relay Outputs, and Analog Output ¹	GMSG10R0
	Graphite Module, Single Loop, One Strain Gage Input, Solid State Outputs, and Analog Output	GMSG10S0
	Graphite Module, Single Loop, Two Strain Gage Inputs, Relay Outputs, and Analog Output ¹	GMSG11R0
	Graphite Module, Single Loop, Two Strain Gage Inputs, Solid State Outputs, and Analog Output	GMSG11S0

A listing of the entire Graphite family of products and accessories can be found at www.redlion.net.

¹ Module is not suitable for use in hazardous locations.

This page intentionally left blank

LIMITED WARRANTY

(a) Red Lion Controls Inc. (the "Company") warrants that all Products shall be free from defects in material and workmanship under normal use for the period of time provided in "Statement of Warranty Periods" (available at www.redlion.net) current at the time of shipment of the Products (the "Warranty Period"). **EXCEPT FOR THE ABOVE- STATED WARRANTY, COMPANY MAKES NO WARRANTY WHATSOEVER WITH RESPECT TO THE PRODUCTS, INCLUDING ANY (A) WARRANTY OF MERCHANTABILITY; (B) WARRANTY OF FITNESS FOR A PARTICULAR PURPOSE; OR (C) WARRANTY AGAINST INFRINGEMENT OF INTELLECTUAL PROPERTY RIGHTS OF A THIRD PARTY; WHETHER EXPRESS OR IMPLIED BY LAW, COURSE OF DEALING, COURSE OF PERFORMANCE, USAGE OF TRADE OR OTHERWISE.** Customer shall be responsible for determining that a Product is suitable for Customer's use and that such use complies with any applicable local, state or federal law.

(b) The Company shall not be liable for a breach of the warranty set forth in paragraph (a) if (i) the defect is a result of Customer's failure to store, install, commission or maintain the Product according to specifications; (ii) Customer alters or repairs such Product without the prior written consent of Company.

(c) Subject to paragraph (b), with respect to any such Product during the Warranty Period, Company shall, in its sole discretion, either (i) repair or replace the Product; or (ii) credit or refund the price of Product provided that, if Company so requests, Customer shall, at Company's expense, return such Product to Company.

(d) **THE REMEDIES SET FORTH IN PARAGRAPH (c) SHALL BE THE CUSTOMER'S SOLE AND EXCLUSIVE REMEDY AND COMPANY'S ENTIRE LIABILITY FOR ANY BREACH OF THE LIMITED WARRANTY SET FORTH IN PARAGRAPH (a).**