

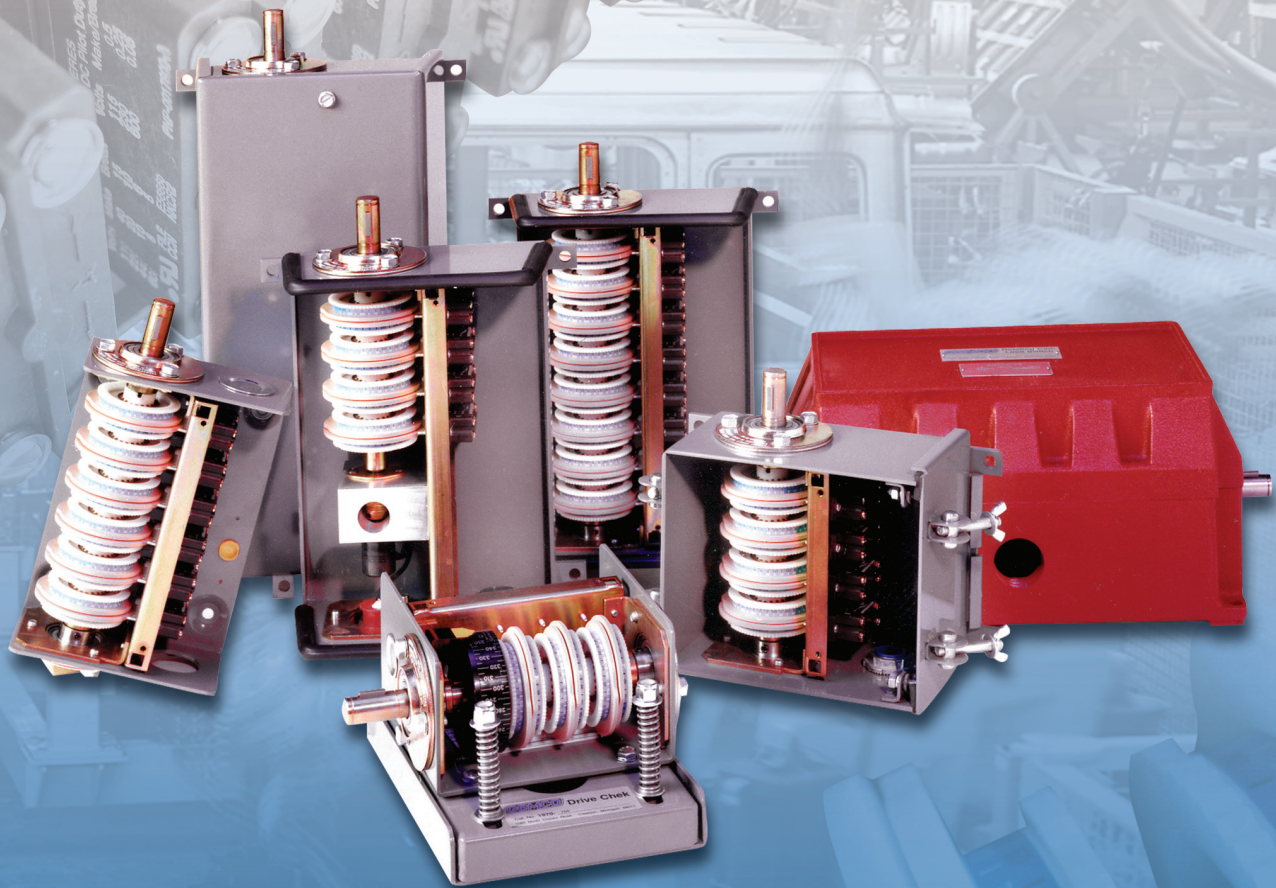

## 1980 Rotating Cam Limit Switches

### Ordering Guide & Technical Information



## Features

- Precision Cam adjustment at any angular position of the Camshaft
- Speeds from 0 to 500 RPM in either direction
- No special Cams required for any contact setting from 4° to 356°
- No tools required to adjust Cam setting
- Accurate repeatability
- GEMCO rugged duty precision snap action switches
- U.L. listed assemblies - Nema 1 and Nema 12 under file E56660, Nema 9 under file E75487

## Accessories

The following accessories can be obtained with the GEMCO Rotating Cam Limit Switch:

- Straight Drive and Right Angle Gear Reducers
- Timing Dial and Timing Dial Window
- Electrical Wiring per Customer's Specification
- Motor Driven Rotating Cam Limit Switch with AC or DC for Adjustable Speed Drives
- Potentiometer driven off the Camshaft
- Spring Return Mechanism
- Plug-In Socket
- Double Ended Shafts
- Pilot Lights
- 3 Way and 4 Way Air Valves directly interchangeable with switches
- Special Conduit Opening
- Special shaft extensions and keyway
- Adjustable Coupling (See Catalog Section 3001)
- Special Cams & Large 6" Cams for Higher Resolution
- Combination Adjustable-In-Motion and Micro-Adjust Circuits (see Catalog Section 1981)
- Electric Clutch and/or Brake
- Separate Terminal Strips
- Add-A-Cam Feature
- Factory Adjustment of Cams Available
- Open Type Units
- Dual Shafts

## For OSHA Standards

- Motion Detector \*
- GEMCO DRIVE-CHEK® \*  
*Either of the above is necessary for mechanical press application*
- Dual Shaft Cam Switch

Consult manufacturer for desired accessories

## Applications

GEMCO's all new Micro-Adjust Rotating Cam Limit Switch is a pilot device used for heavy duty material handling mechanisms, mechanical presses,\* packaging machines, rotary table, and in many other applications where accurate, repetitive, and sequential operations are required in control circuitry.

When motion is expressed in shaft rotation, either through a roller chain, gear train, or directly, the GEMCO Rotating Cam Limit Switch makes it possible to open or close independent circuits at any desired angular position.

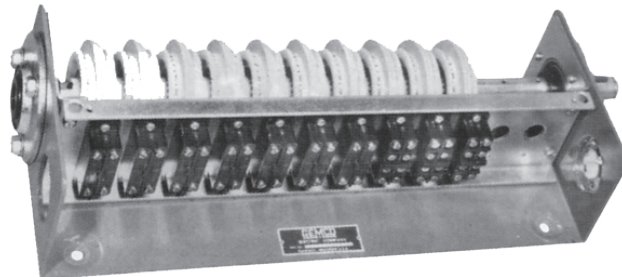

FIG. 1

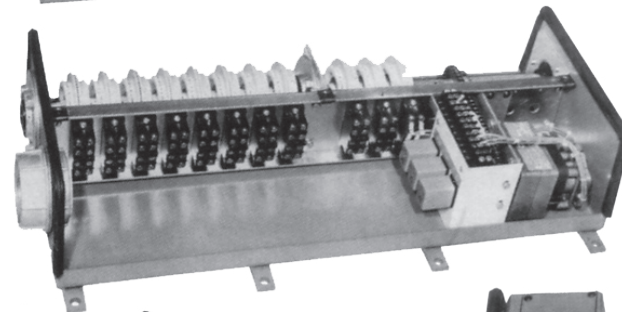

FIG. 2

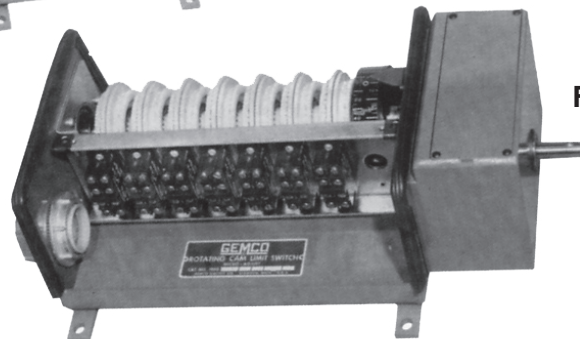
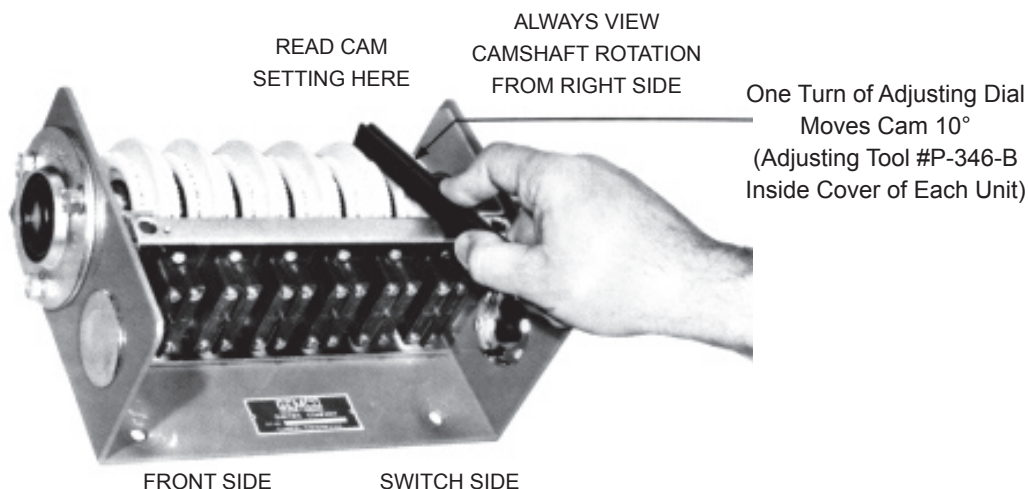

FIG. 3

## Easy Set-Up Procedure



## Mounting of Unit

Mount the assembly and couple input shaft to the driving member with the shaft keyway up and in line with the positioning arrow on the bearing end plate. The machine should be in the start cycle position.

## Establishing Camshaft Direction of Rotation

Cam settings should be made with the Camshaft uppermost to the viewer. The picture at the top right illustrates this viewing position and also shows the adjusting tool being applied to the adjusting wheel. Shaft rotation is always established off the right end of the unit even when the input shaft, whether direct or through a gear reducer, is situated at the left end. As an aid to designating shaft rotation when a gear reducer is used, consult page 14 of this catalog section.

## Cam Settings

For clockwise rotation, set "make" angle with the black dial and "break" with the red dial for dwell settings less than 180°. Reverse colors for dwells 180° or greater.

For counterclockwise rotation, set "make" angle with the white dial and "break" with the yellow dial. Reverse colors for dwells 180° or greater.

Switch connections should be made in accordance with the illustrations to the right, which incidentally are both clockwise rotating examples.

## TYPICAL SETTINGS AT BEGINNING OF MACHINE CYCLE

OPEN  CLOSED

ALL CAMS SHOWN AT START CYCLE POSITION

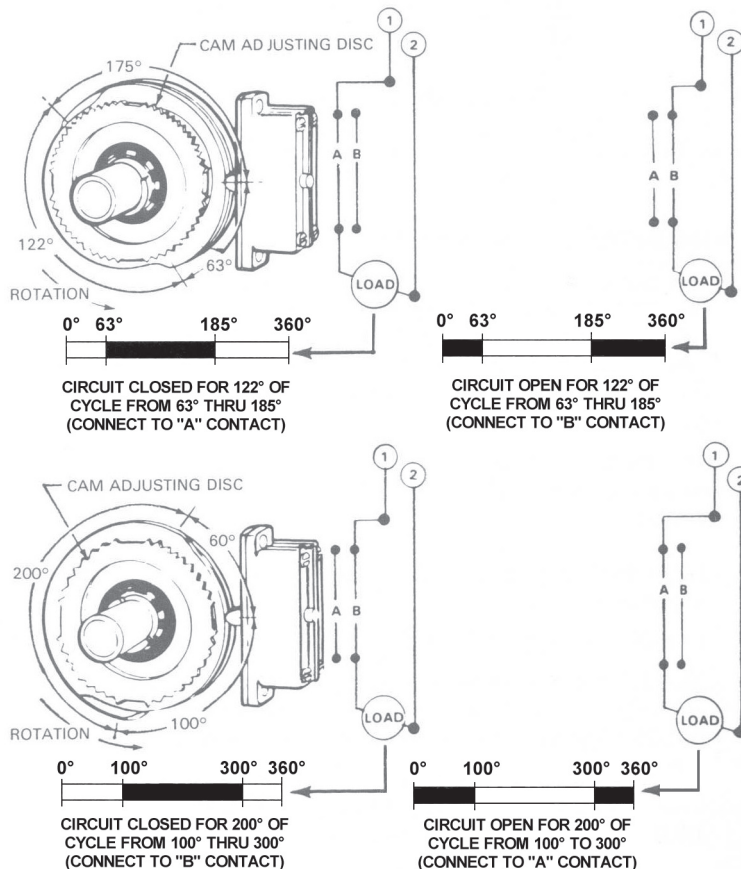



## Description

Precision, rugged duty snap action switches, extremely accurate cam adjustments with a heavy duty shaft, rugged case and lifetime sealed ball bearings, have been combined by GEMCO to provide the most versatile and dependable Rotating Cam Limit Switch available.

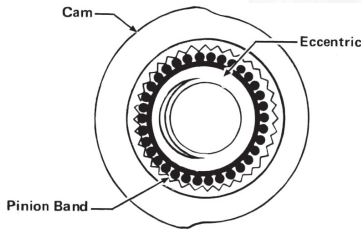
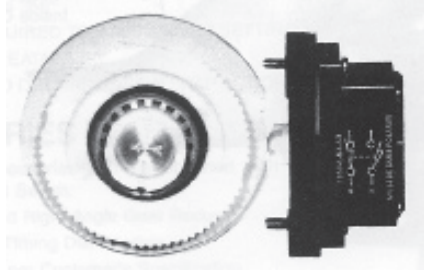

## No Special Cams are Required

The accurate cam adjustments are made possible by the use of a separate reduction drive in each half of a circuit cam block assembly. This drive provides a 36 to 1 ratio which means that one revolution of the adjustment wheel will advance or retard the cam setting by 10 degrees.

For most applications, therefore, no special cams are necessary and settings may be changed at any angular position of the camshaft.

- **Lifetime Sealed Ball Bearing** allows mounting in any position.
- **Large Cover Openings** for ease of wiring.
- **No Minimum Speed** is specified because snap action contacts are used. Maximum rated speed of the Camshaft is 500 RPM and can be rotated either clockwise or counterclockwise.
- Two types of compact integrally **Mounted Gear Reducers** are available with ratios of 1:1 through 600:1. They can also be supplied with speed multipliers up to 1:8.

## Technical Data

- The maximum temperature with full electrical load is 185°F. The minimum operating temperature is -50°F minimum cam adjusting temperature is -10°F.
- Standard GEMCO Rotating Cam Limit Switches have a rating of 50 pounds end thrust and 500 pounds radial load on standard shaft extensions.
- Torque Required - .6 lb. - In/Circuit.
- Repeatability +/- 1/4°

## Snap Action Switches

All standard GEMCO Rotating Cam Limit Switches employ SPDT precision type snap action switches which provide the advantage of double-break contacts and are actuated at a uniform rate to give long life. DPDT switches can be provided upon request. Any number of circuits from 1 to 40 may be supplied as standard in Nema 1, Nema 4, Nema 7 and Nema 12 enclosures.

Each switch setting can be adjusted to your circuit requirements. An unlimited selection of circuit arrangements is available with the GEMCO Rotating Cam Limit Switch, with no special mounting cams, dogs, etc. for contact settings.

## GEMCO Microadjust Cams Provide Unlimited Circuit Versatility

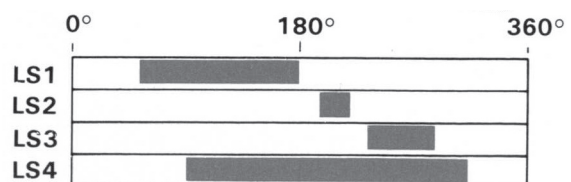
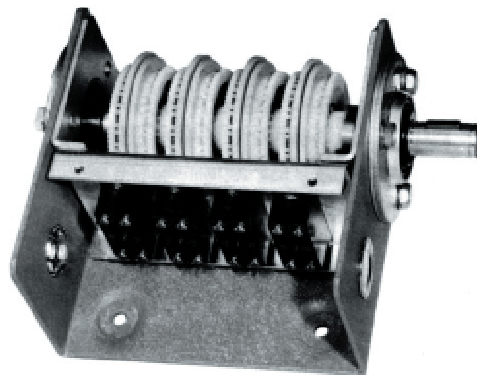

## Electrical Switches

### Description

The GEMCO Precision Snap Switches are designed for industrial duty applications where compact size, complete reliability and millions of trouble free operations are required.

The housing is molded material which has excellent resistance to arcing and carbon tracking. The operating button is of molded nylon, a material with excellent wear characteristics.

The button is well guided at the top and bottom to insure accurate repeatability and minimum wear.

Any combination of single-pole double-throw or double-pole double-throw snap action switches can be supplied with the GEMCO Rotating Cam Limit Switch.

The switches are individually mounted and can be readily replaced without the need of adjustment or alignment. All switches have binder head terminal screws which are accessible for wiring with either stripped or wire lug connections.



**NOTE:** Refer to Catalog Section 1950 for detailed information pertaining to all Standard and Special Switch Options.

Switch replacement is recommended every 15 million cycles.

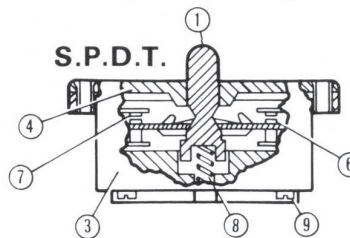
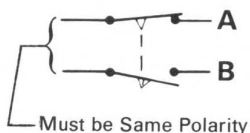
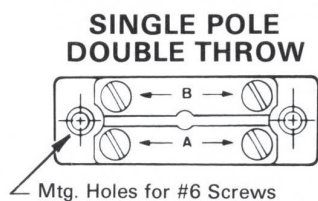

1. Plunger
2. Eyelet
3. Enclosure
4. Cover
5. Contact Spring
6. Movable Contact Ass'y
7. Stationary Contact Ass'y
8. Return Spring
9. Terminal Screws

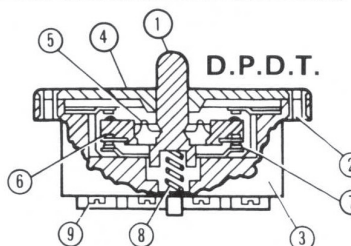
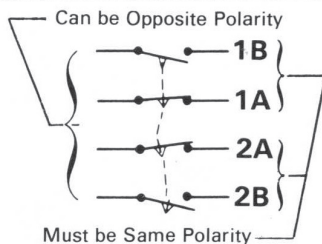
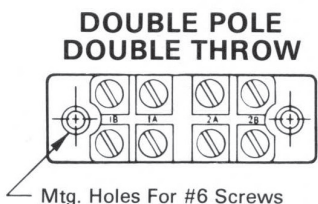

Electrical Contact Ratings													
Switch Type	Contacts	Volts	AC					Continuous Carrying Amps	Make, Break and Continuous Carrying Amperes	Volts	DC		
			Inductive Pilot Duty 35% Power Factor				Resistive 75% Power Factor				Inductive Pilot Duty and Resistive		
			Make		Break		Make, Break and Continuous Carrying Amperes				Make and Break Amps		
			Amps	VA	Amps	VA					Single-Throw	Double-Throw	Continuous Carrying Amps
1950-4	DPDT	115	30	3450	3	345	10	10	115	1.0	0.2	10	
		230	15	3450	1.5	345	10	10	230	0.3	0.1	10	
		440	7.5	3450	0.75	345	10	10	600	0.1	--	10	
		575	6	3450	0.6	345	10	10	--	--	--	--	
1950-1	SPDT	110	40	--	15	--	15	15	115	0.5	0.25	15	
		220	20	--	10	--	15	15	230	0.25	0.1	15	
		440	10	--	6	--	15	15	600	0.05	--	15	
		600	8	--	5	--	15	15	--	--	--	--	

## 1980 1 04 - R - SP - X

NUMBER OF CAMS

ENCLOSURE TYPE

1980	Standard
1980R	Built-In Resolver

SEE PAGE 10 FOR CATALOG NUMBER

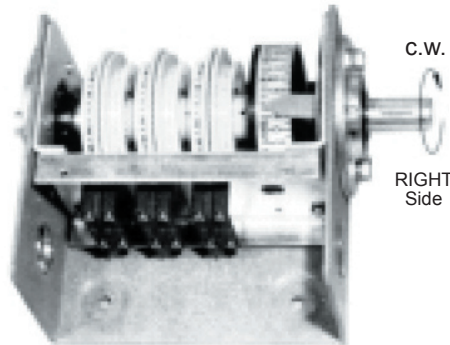

HORIZONTAL Mtg.

NOTE: Timing dial always mounted at right hand and as shown, takes one circuit space, as viewed from right side.

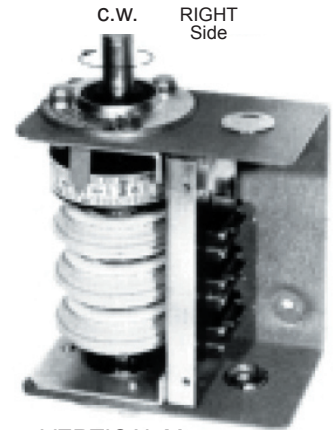

VERTICAL Mtg.

TIMING DIAL*	
X	NO TIMING DIAL
HORIZ. Mtg.	TD1 C.W. ROTATION
	TD2 C.C.W. ROTATION
VERT. Mtg.	TD3 C.W. ROTATION
	TD4 C.W. ROTATION

\* NOTE: If window is required for timing dial, replace D with W in Catalog Number (i.e., TW1)

TIMING DIAL DECAL	
TD1	NP-76-B
TD2	NP-71-B
TD3	NP-78-B
TD4	NP-77-B

SWITCH OPTION	
—	NO SWITCH OPTION
R	RUBBER BOOT

SWITCH TYPE	
SP	SINGLE POLE DOUBLE THROW
DP	DOUBLE POLE DOUBLE THROW
**SPP	SPDT WITH PLUG-IN SOCKET
**DPP	DPDT WITH PLUG-IN SOCKET
SPK	SPDT WITH CLAMP TERMINAL

SHAFT EXTENSION	
R	RIGHT HAND
L	LEFT HAND
D	DOUBLE ENDED
X	NO SHAFT EXTENSION OPPOSITE GEAR BOX
Y	SHAFT EXTENSION OPPOSITE GEAR BOX

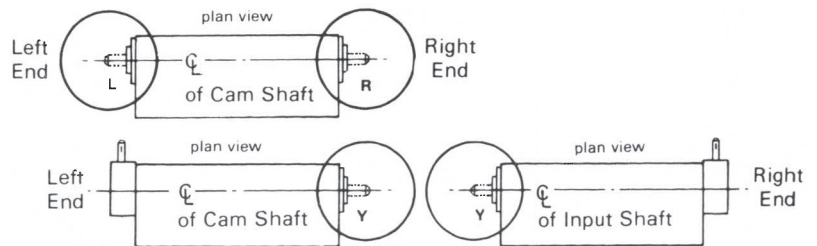

\*\* When plug-in switches are specified, one extra circuit space must be allowed for in the enclosure.

**R**

	TYPE OF GEAR REDUCER
<b>R</b>	RIGHT ANGLE
<b>S</b>	STRAIGHT DRIVE
<b>M</b>	MULTIPLIER DRIVE

**1.5**

RATIO	GEAR REDUCER	
	Straight Drive	Right Angle
1		1.1
1.2		1.2:1
1.25	1.25:1	1.25:1
1.33	1.33:1	1.33:1
1.5	1.5:1	1.5:1
1.6	1.6:1	1.6:1
2	2:1	2:1
2.2	2.2:1	
2.5	2.5:1	2.5:1
3	3:1	3:1
4	4:1	4:1
4.75		4.75:1
5	5:1	5:1
6	6:1	6:1
7	7:1	7:1
7.5	7.5:1	7.5:1
8	8:1	8:1
8.5	8.5:1	8.5:1
10	10:1	10:1
12	12:1	12:1
12.5		12.5:1
14	14:1	14:1
15	15:1	15:1
16	16:1	16:1
17		17:1
18	18:1	18:1
20	20:1	20:1
24	24:1	24:1
25	25:1	25:1
28	28:1	28:1
30	30:1	30:1
32	32:1	32:1
35	35:1	
36	36:1	36:1
40	40:1	40:1
48	48:1	48:1
50	50:1	50:1
60	60:1	60:1
64	64:1	64:1
72		72:1
80	80:1	80:1
96	96:1	96:1
100	100:1	100:1
200	200:1	
400	400:1	
500	500:1	
600	600:1	

GEAR MULTIPLIER	
2	1:2
3	1:3
4	1:4
5	1:5
*6	1:6
*7	1:7
*8	1:8

**R1**

NOTE: Gear reducer must be ordered in the required position. It cannot be changed in the field.

### SHAFT LOCATION

#### Right Angle Gear Reducer

Check Shaft Location for Possible Interference

R1  
R2  
R3  
R4  
R5  
R6  
R7  
R8

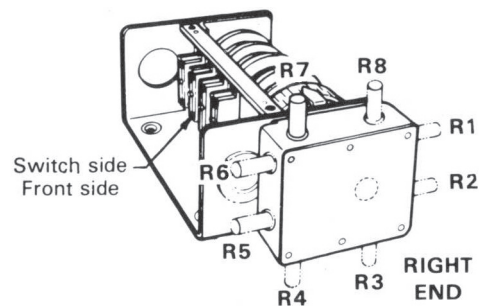

L1  
L2  
L3  
L4  
L5  
L6  
L7  
L8

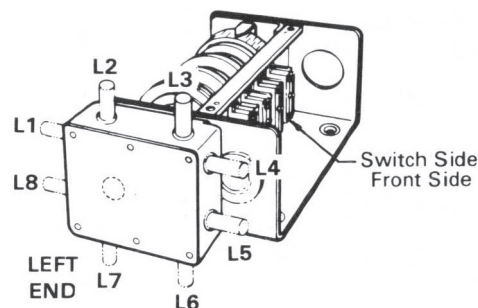

#### Straight Drive Gear Reducer

R\*\*

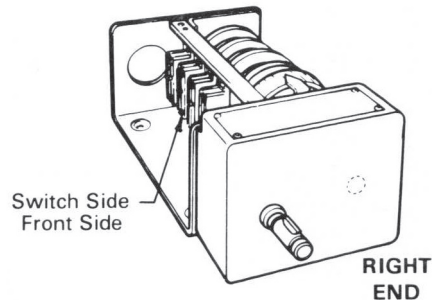

L\*\*

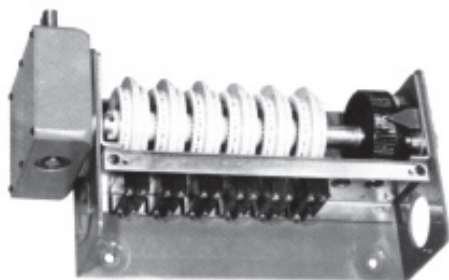
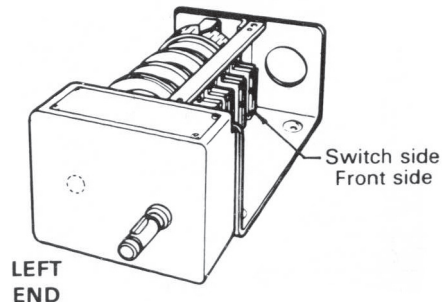

\*\* For straight drive gear reducers with 1970 Drive Chek, refer to section 1970 for shaft extension location.

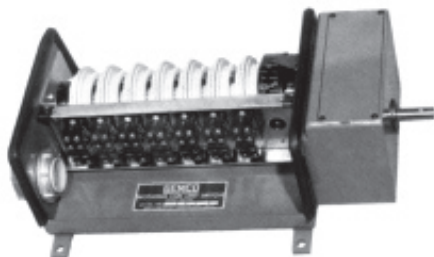

\* Number of Circuits Restricted — Consult Factory

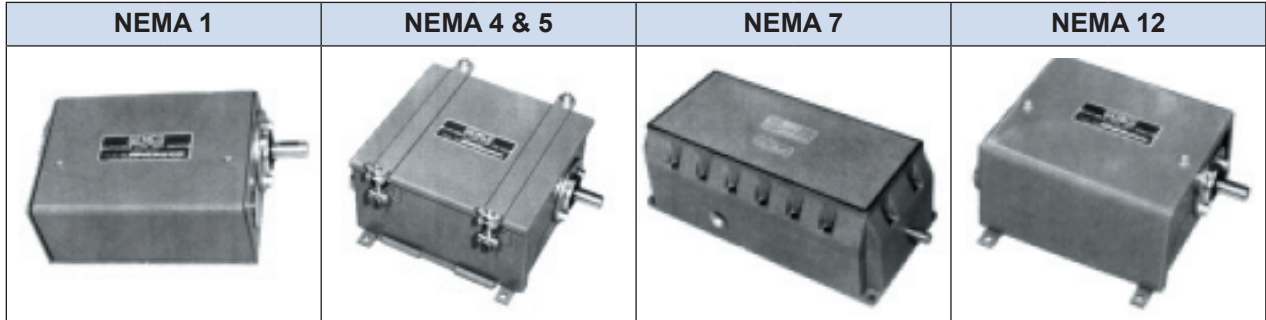

Number of Circuits	NEMA 1		NEMA 4 & 5		NEMA 7		NEMA 12	
	Catalog Number	Cat. No. w/Resolver	Catalog Number	Cat. No. w/Resolver	Catalog Number	Cat. No. w/Resolver	Catalog Number	Cat. No. w/Resolver
1	1980-101	1980R-101	1980-401	1980R-401	1980-701	Consult Factory	1980-1201	1980R-1201
2	1980-102	1980R-102	1980-402	1980R-402	1980-702		1980-1202	1980R-1202
3	1980-103	1980R-103	1980-403	1980R-403	1980-703		1980-1203	1980R-1203
4	*1980-104	1980R-104	1980-404	1980R-404	1980-704		*1980-1204	1980R-1204
5	1980-105	1980R-105	1980-405	1980R-405	1980-705		1980-1205	1980R-1205
6	*1980-106	1980R-106	1980-406	1980R-406	1980-706		*1980-1206	1980R-1206
7	1980-107	1980R-107	1980-407	1980R-407	1980-707		1980-1207	1980R-1207
8	*1980-108	1980R-108	1980-408	1980R-408	1980-708		*1980-1208	1980R-1208
9	1980-109	1980R-109	1980-409	1980R-409	1980-709		1980-1209	1980R-1209
10	1980-110	1980R-110	1980-410	1980R-410	1980-710		1980-1210	1980R-1210
11	1980-111	1980R-111	1980-411	1980R-411	1980-711		1980-1211	1980R-1211
12	*1980-112	1980R-112	1980-412	1980R-412	1980-712		*1980-1212	1980R-1212
13	1980-113		1980-413		1980-713		1980-1213	
14	1980-114		1980-414		1980-714		1980-1214	
15	1980-115		1980-415		1980-715		1980-1215	
16	1980-116		1980-416		1980-716		1980-1216	
17	1980-117		1980-417		1980-717		1980-1217	
18	1980-118		1980-418		1980-718		1980-1218	
19	1980-119		1980-419		1980-719		1980-1219	
20	1980-120		1980-420		1980-720		1980-1220	
21	1980-121		1980-421		1980-721		1980-1221	
22	1980-122		1980-422		1980-722		1980-1222	
23	1980-123		1980-423		1980-723		1980-1223	
24	1980-124		1980-424		1980-724		1980-1224	
25	1980-125		1980-425		1980-725		1980-1225	
26	1980-126		1980-426		1980-726		1980-1226	
27	1980-127		1980-427		1980-727		1980-1227	
28	1980-128		1980-428		1980-728		1980-1228	
29	1980-129		1980-429		1980-729		1980-1229	
30	1980-130		1980-430		1980-730		1980-1230	
31	1980-131		1980-431		1980-731		1980-1231	
32	1980-132		1980-432		1980-732		1980-1232	
33	1980-133		1980-433		1980-733		1980-1233	
34	1980-134		1980-434		1980-734		1980-1234	
35	1980-135		1980-435		1980-735		1980-1235	
36	1980-136		1980-436		1980-736		1980-1236	
37	1980-137		1980-437		1980-737		1980-1237	
38	1980-138		1980-438		1980-738		1980-1238	
39	1980-139		1980-439		1980-739		1980-1239	
40	1980-140		1980-440		1980-740		1980-1240	

\* Stock with a right hand shaft and SPDT switches.

SINGLE SHAFT EXTENSION

MAXIMUM SPEED 500 R.P.M.

CONSULT FACTORY FOR OPTIONS AND NON-LISTED CATALOG NUMBERS.



## Shaft Extension

The GEMCO Rotating Cam Limit Switch can be supplied with the desired shaft extension. The standard shaft extension can be specified in the catalog numbering system on page 8.

To determine the shaft extension symbol, the Rotating Cam Limit Switch must be viewed from the

switch side of the assembly as shown. The shaft extension can be specified as either:

- L = Left shaft extension
- R = Right shaft extension
- D = Double shaft extension (both ends)
- X = No shaft extension opposite the gear box
- Y = Shaft extension opposite gear box

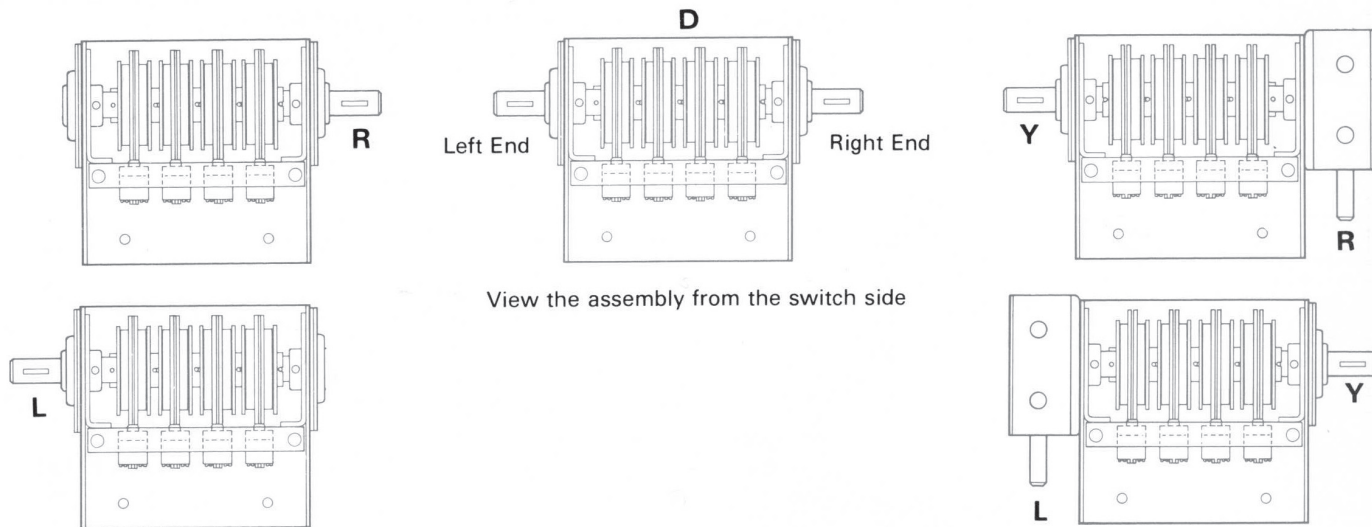

## Switch Type

The GEMCO Precision Snap Switches are specifically designed for industrial duty applications where reliability, ease of wiring and millions of trouble free cycles are required.

The GEMCO Rotating Cam Limit Switch can be supplied with either a basic single-pole double-throw (SPDT), double-pole double-throw (DPDT), or a combination of both types.

A plug-In socket can be supplied with either the SPDT or DPDT switches.

**NOTE:** Call Sales at 1-800-635-0289 for information about 1950 Snap Switch parts and options.

The type of snap switch can be specified in the catalog numbering system on page 8.

- SP = Single-pole double-throw
- DP = Double-pole double throw
- SPP = Single-pole double-throw with a plug-in socket
- DPP = Double-pole throw with a plug socket

The Plug-In Socket eliminates error due to disconnecting and connecting wires during replacement of the snap switch. A marking strip is supplied with each plug-in socket for ease of wire identification.

**Switch Replacement is Recommended Every 15 Million Cycles.**

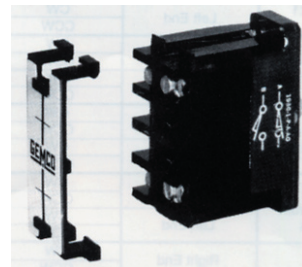
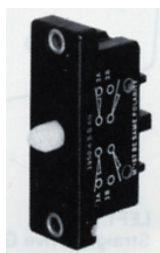
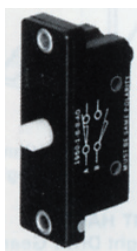

## SELECTING THE CORRECT SIZE ENCLOSURE

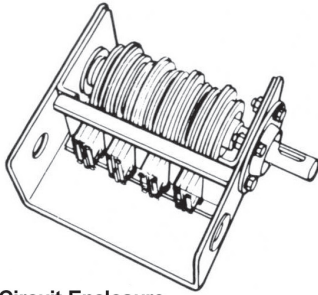

4 Circuit Enclosure  
Without A Timing Dial  
Exp. 1980-104-R-SP-X

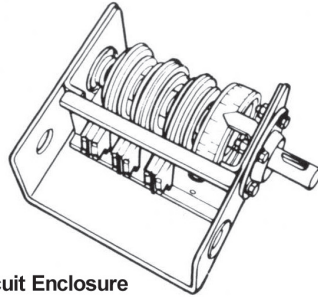

4 Circuit Enclosure  
With Timing Dial Added  
Only 3 Circuits Remain  
Exp. 1980-103-R-SP-TD

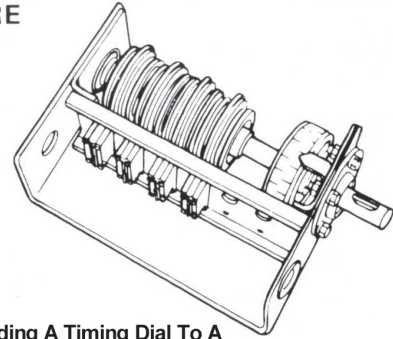

Adding A Timing Dial To A  
4 Circuit System, 6 Circuit  
Enclosure is Required  
Exp. 1980-104-R-SP-TD

## DETERMINING DIRECTION OF CAMSHAFT — TIMING DIAL ROTATION

RIGHT ANGLE GEAR REDUCER ROTATION Rotation Input Shaft Versus Camshaft		
GEAR REDUCER POSITION	GEAR REDUCER INPUT SHAFT ROTATION	CAMSHAFT TIMING DIAL ROTATION
R1 or L1	CW	CW
	CCW	CCW
R2 or L2	CW	CCW
	CCW	CW
R3 or L3	CW	CW
	CCW	CCW
R4 or L4	CW	CCW
	CCW	CW
R5 or L5	CW	CW
	CCW	CCW
R6 or L6	CW	CCW
	CCW	CW
R7 or L7	CW	CW
	CCW	CCW
R8 or L8	CW	CCW
	CCW	CW

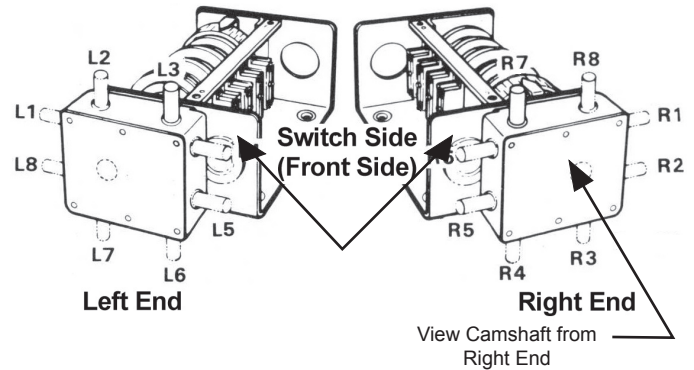

**CW = Clockwise**  
**CCW = Counter Clockwise**

STRAIGHT DRIVE GEAR REDUCER Input Shaft Rotation Versus Cam Shaft Rotation			
STRAIGHT DRIVE GEAR REDUCER	LOCATION OF INPUT SHAFT	GEAR REDUCER INPUT SHAFT ROTATION	CAMSHAFT TIMING DIAL ROTATION
All Ratios From 1.25:1 to 3:1	Right End	CW	CCW
	Left End	CW	CW
All Ratios From 4:1 to 8.5:1	Right End	CCW	CCW
	Left End	CW	CW
All Ratios From 10:1 to 600:1	Right End	CW	CW
	Left End	CCW	CCW
All Gear Multipliers From 1:2 to 1:3	Right End	CW	CCW
	Left End	CCW	CCW
All Gear Multipliers From 1:4 to 1:8	Right End	CW	CW
	Left End	CCW	CCW

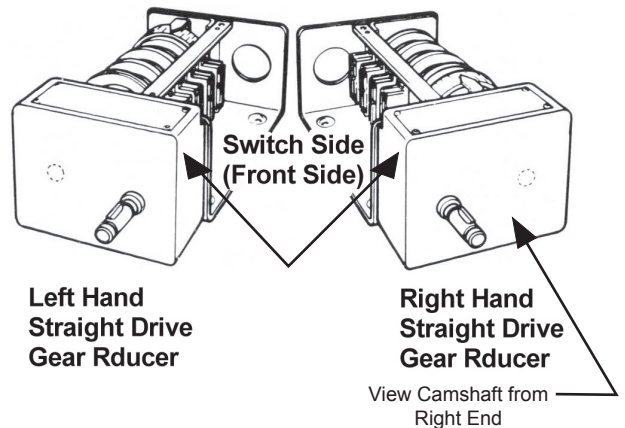

## Replacement Cam Assemblies

### Standard Cam Assembly

Part No. SD-1178-C  
(includes two cams -  
Part Nos. P-356-B and P-357-B)



### Blank Cam Assembly

Part No. SD-1140-C  
(includes two blank cams -  
Part No. P-271-B)

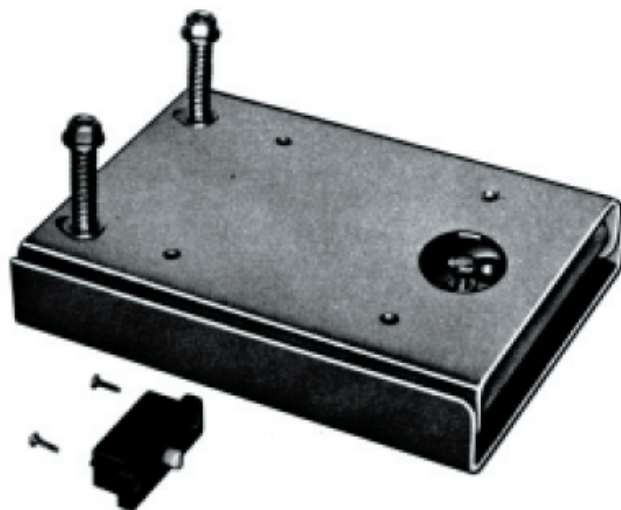

### Special Cams

A Blank Cam Assembly (Part No. SD-1140-C) can be supplied in place of the Standard Cam Assembly, (Part No. SD-1178-C) at no additional charge, when specified. Advise number required and location.

**A drawing of the Cam shape must be given with the order.** Generally, two cams are required per circuit. When ordering special cut cams, the customer will supply a detail of the cam profile and the electrical timing chart showing the contact setting as required.

### Special Conduit Openings



Specify conduit size and location.

## Description

The DRIVE-CHEK is a multi-purpose sub base that is mounted under a chain or belt driven mechanism. The unit serves three purposes; a broken chain or belt detector, a chain or belt tightener, and a shock and vibration isolator.

A GEMCO Indicator Switch is provided with each DRIVE-CHEK Unit to indicate when a drive belt or chain failure has occurred. Shock and vibration from the machine to the hinge plate of the DRIVE-CHEK Unit are dampened by coil springs on one end of the hinge plate and an elastomeric support on the other end.

The springs also maintain a constant tension in the drive belt or chain. DRIVE-CHEK is of rugged welded construction and is painted to prevent corrosion. The drive chain or belt can be attached to the mechanism being driven from either above or below the DRIVE-CHEK base.

The DRIVE-CHEK base can be purchased as a separate item for field mounting or factory assembled to the 1980 camswitch. If factory installation is desired, order as separate item and specify as being assembled in the description.

A GEMCO single-pole double-throw switch with mounting plate is supplied with each DRIVE-CHEK Unit and can be easily mounted inside the GEMCO Rotating Cam Limit Switch enclosure. A GEMCO double-pole double-throw switch can also be supplied.



## NEMA 1 Dimensions

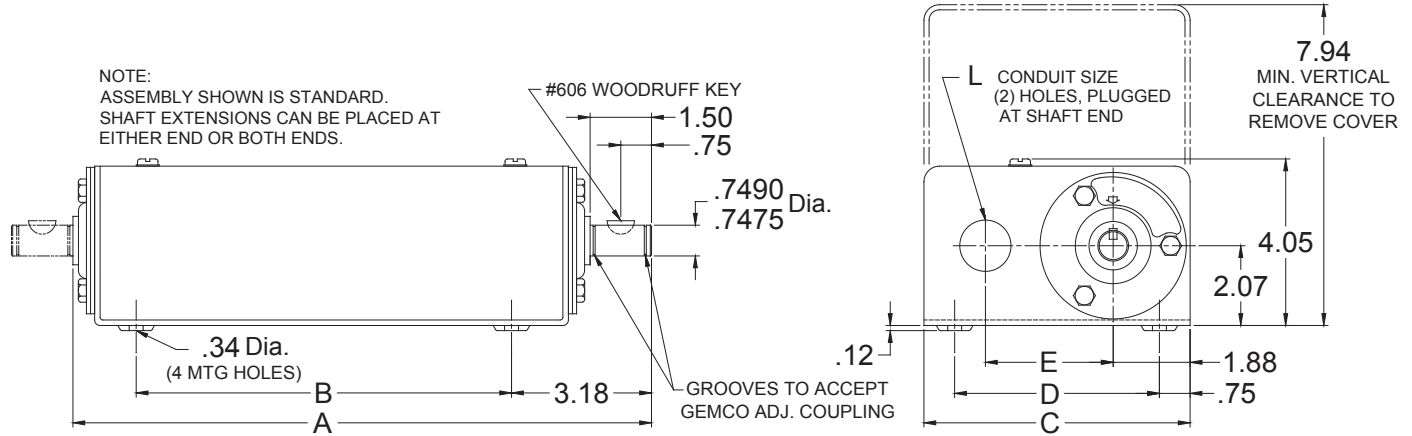

No. of Circuits	A	A-S	A-R	B	C	D	E	L	Wt. Approx. Gross
2 to 4	9.28	12.12	9.38	4.42	6.50	5.00	3.12	.75	12 lb.
5 to 6	11.72	14.56	11.82	6.86	6.50	5.00	3.12	1.25	14 lb.
7 to 8	14.16	17.00	14.26	9.30	6.50	5.00	3.12	1.25	16 lb.
9 to 12	19.04	21.88	19.14	14.18	6.50	5.00	3.12	1.25	21 lb.
13 to 16	25.45	28.29	25.55	20.60	7.00	5.50	3.40	2.00	35 lb.
17 to 20	30.33	33.17	30.43	25.48	7.00	5.50	3.40	2.00	46 lb.
21 to 24	35.21	38.05	35.31	30.36	7.00	5.50	3.40	2.00	55 lb.
25 to 28	41.62	44.46	41.72	36.76	7.00	5.50	3.40	2.00	
29 to 32	46.50	49.34	46.60	41.64	7.00	5.50	3.40	2.00	
33 to 36	51.38	54.22	51.48	46.52	7.00	5.50	3.40	2.00	
37 to 40	56.26	59.10	56.36	51.40	7.00	5.50	3.40	2.00	

Straight Drive					
Ratio	X	Y	Ratio	X	Y
1.25:1	2.71	2.07	32:1	3.82	2.26
2:1	2.63	2.07	35:1	3.82	2.32
2.2:1	3.13	2.07	40:1	3.82	1.88
3:1	2.80	2.07	48:1	3.82	2.01
4:1	4.13	2.07	50:1	3.82	2.07
5:1	4.38	2.07	80:1	3.82	2.44
6:1	4.30	2.07	96:1	3.82	2.32
7:1	4.55	2.07	100:1	3.82	2.07
8:1	4.51	2.07	200:1	3.82	2.07
8.5:1	3.99	2.07	400:1	3.82	1.91
10:1	3.82	1.88	500:1	3.82	1.76
12:1	3.82	2.01	600:1	3.82	2.07
14:1	3.82	2.13	1:2	2.63	2.07
15:1	3.82	2.19	1:3	2.80	2.07
16:1	3.82	2.26	1:4	4.13	2.07
20:1	3.82	1.88	1:5	4.38	2.07
24:1	3.82	2.01	1:6	4.30	2.07
25:1	3.82	2.07	1:7	3.34	2.13
28:1	3.82	2.13	1:8	3.57	2.07
30:1	3.82	2.19			

Right Angle Drive			
Ratio	Y	Ratio	Y
1:1	1.00	15:1	1.250
1.2:1	1.375	16:1	1.312
1.25:1	1.125	17:1	1.368
1.33:1	1.750	18:1	1.437
1.5:1	1.250	20:1	.937
1.6:1	1.625	24:1	1.062
2:1	1.500	25:1	1.875
2.5:1	1.750	28:1	1.187
3:1	2.00	30:1	1.250
4:1	1.875	32:1	1.312
4.75:1	.906	36:1	1.437
5:1	.937	40:1	1.562
6:1	1.062	48:1	1.812
7:1	1.187	50:1	1.875
7.5:1	1.250	60:1	1.156
8:1	1.312	64:1	1.218
10:1	.937	72:1	1.344
12:1	1.062	80:1	1.469
12.5:1	1.875	96:1	1.719
14:1	1.187	100:1	1.781

NOTE:  
Add 4 lbs. with Right  
Angle Gear Reducer.  
Add 6 lbs. with  
Straight Drive Gear  
Reducer.

Consult factory  
for Gear Reducer  
dimensions.

## NEMA 1 with Straight Drive Gear Reducer

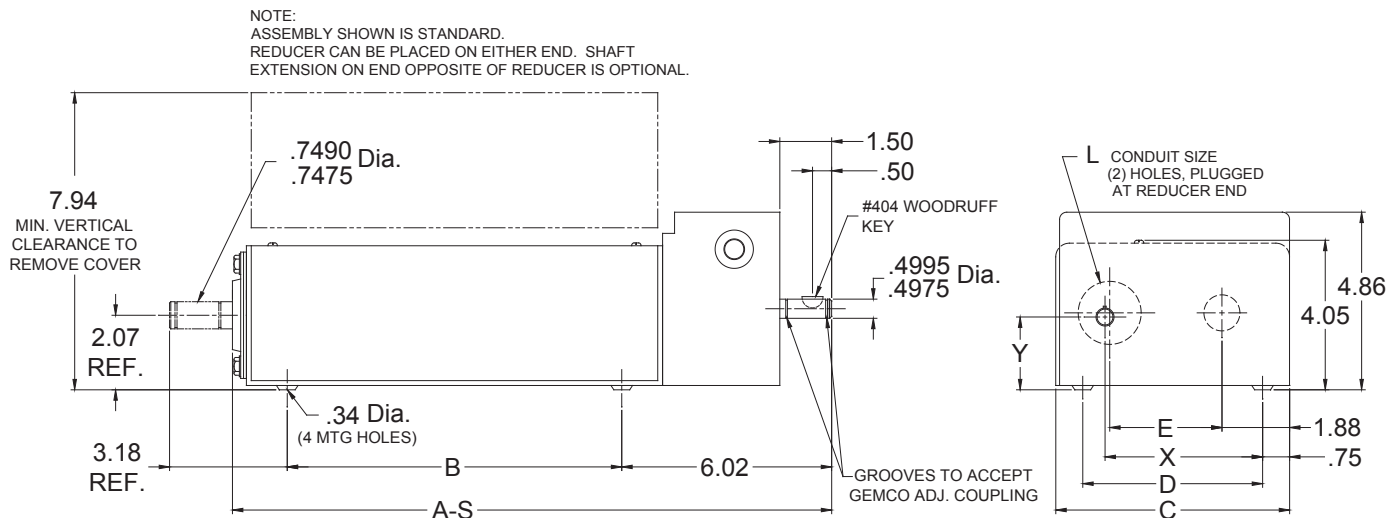

## NEMA 1 with Right Angle Gear Reducer

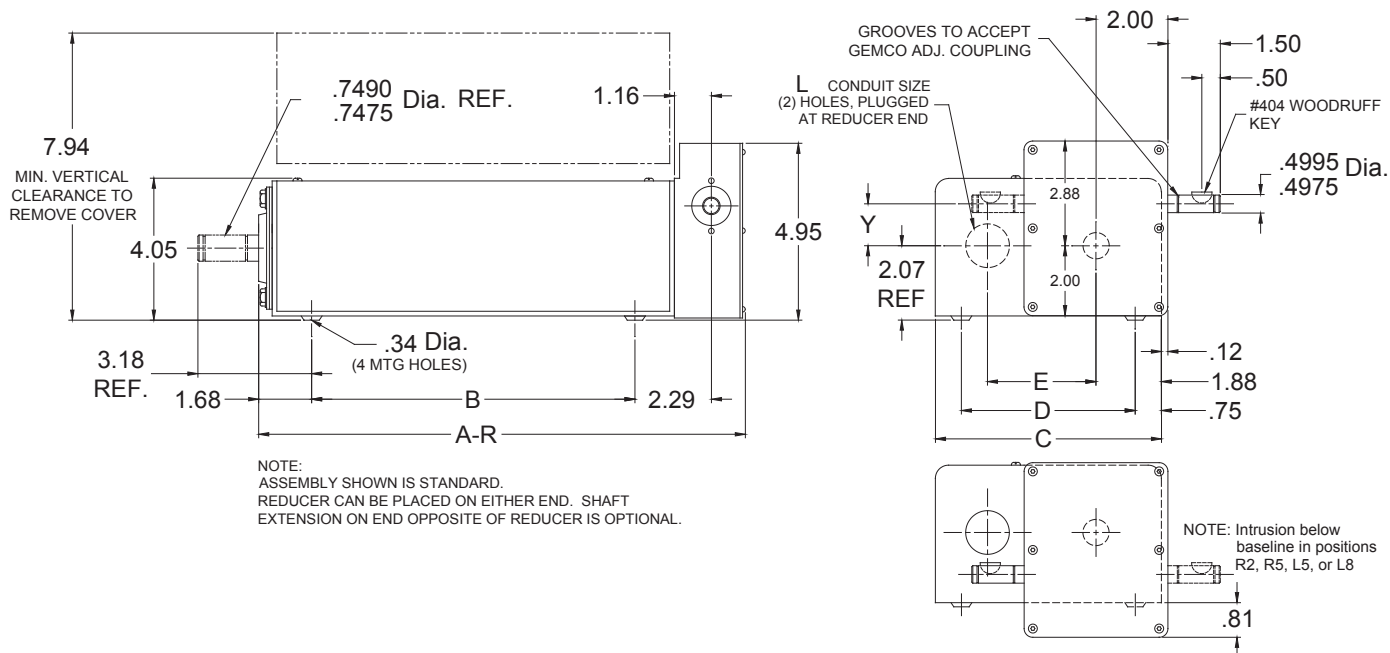



## Nema 4 & 5 Dimensions

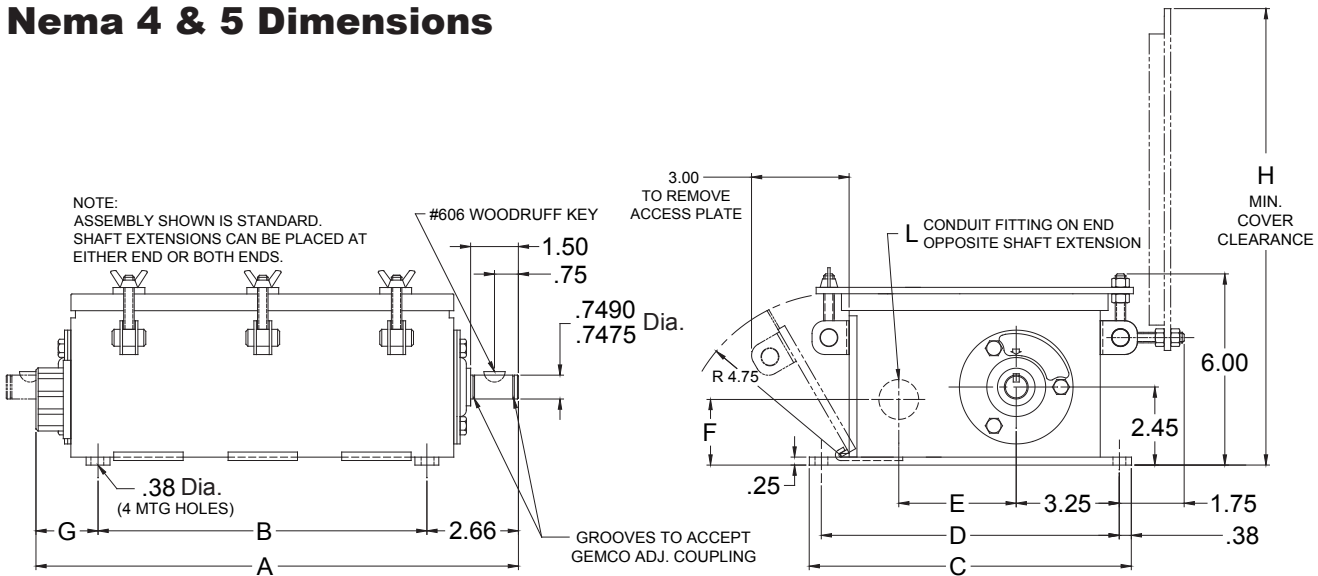

No. of Circuits	A	A-S	A-R	B	C	D	E	F	G	H	L	Wt. Approx. Gross
2 to 4	9.69	12.53	9.78	5.45	10.12	5.00	9.38	2.06	1.58	13.64	.75	18 lb.
5 to 6	12.24	15.08	12.32	7.89	10.12	5.00	9.38	2.06	1.69	13.64	1.25	22 lb.
7 to 8	14.68	17.52	14.78	10.33	10.12	5.00	9.38	2.06	1.69	13.64	1.25	32 lb.
9 to 12	19.56	22.40	19.66	15.21	10.12	5.00	9.38	2.06	1.69	13.64	1.25	50 lb.
13 to 16	26.02	28.86	26.11	21.62	12.12	5.50	11.38	2.81	1.74	15.64	2.00	65 lb.
17 to 20	30.90	33.73	30.99	26.50	12.12	5.50	11.38	2.81	1.74	15.64	2.00	75 lb.
21 to 24	35.78	38.62	35.87	31.38	12.12	5.50	11.38	2.81	1.74	15.64	2.00	
25 to 28	42.19	45.02	42.27	37.80	12.12	5.50	11.38	2.81	1.74	15.64	2.00	
29 to 32	47.07	49.91	47.15	42.66	12.12	5.50	11.38	2.81	1.74	15.64	2.00	
33 to 36	51.95	54.79	52.03	47.54	12.12	5.50	11.38	2.81	1.74	15.64	2.00	
37 to 40	56.83	59.67	56.92	52.42	12.12	5.50	11.38	2.81	1.74	15.64	2.00	

Straight Drive					
Ratio	X	Y	Ratio	X	Y
1.25:1	4.83	2.45	32:1	5.94	2.64
2:1	4.75	2.45	35:1	5.94	2.70
2.2:1	5.25	2.45	40:1	5.94	2.26
3:1	4.92	2.45	48:1	5.94	2.39
4:1	6.25	2.45	50:1	5.94	2.45
5:1	6.50	2.45	80:1	5.94	2.82
6:1	6.42	2.45	96:1	5.94	2.70
7:1	6.67	2.45	100:1	5.94	2.45
8:1	6.63	2.45	200:1	5.94	2.45
8.5:1	6.11	2.45	400:1	5.94	2.45
10:1	5.94	2.26	500:1	5.94	2.29
12:1	5.94	2.39	600:1	5.94	2.14
14:1	5.94	2.51	1:2	4.75	2.45
15:1	5.94	2.57	1:3	4.92	2.45
16:1	5.94	2.64	1:4	6.25	2.45
20:1	5.94	2.26	1:5	6.50	2.45
24:1	5.94	2.39	1:6	6.42	2.45
25:1	5.94	2.45	1:7	5.46	2.51
28:1	5.94	2.51	1:8	5.69	2.45
30:1	5.94	2.57			

Right Angle Drive			
Ratio	Y	Ratio	Y
1:1	1.00	15:1	1.250
1.2:1	1.375	16:1	1.312
1.25:1	1.125	17:1	1.368
1.33:1	1.750	18:1	1.437
1.5:1	1.250	20:1	.937
1.6:1	1.625	24:1	1.062
2:1	1.500	25:1	1.875
2.5:1	1.750	28:1	1.187
3:1	2.00	30:1	1.250
4:1	1.875	32:1	1.312
4.75:1	.906	36:1	1.437
5:1	.937	40:1	1.562
6:1	1.062	48:1	1.812
7:1	1.187	50:1	1.875
7.5:1	1.250	60:1	1.156
8:1	1.312	64:1	1.218
10:1	.937	72:1	1.344
12:1	1.062	80:1	1.469
12.5:1	1.875	96:1	1.719
14:1	1.187	100:1	1.781

**NOTE:**  
Add 4 lbs. with Right Angle Gear Reducer.  
Add 6 lbs. with Straight Drive Gear Reducer.

Consult factory for Gear Reducer dimensions.

## Nema 4 & 5 with Straight Drive Gear Reducer

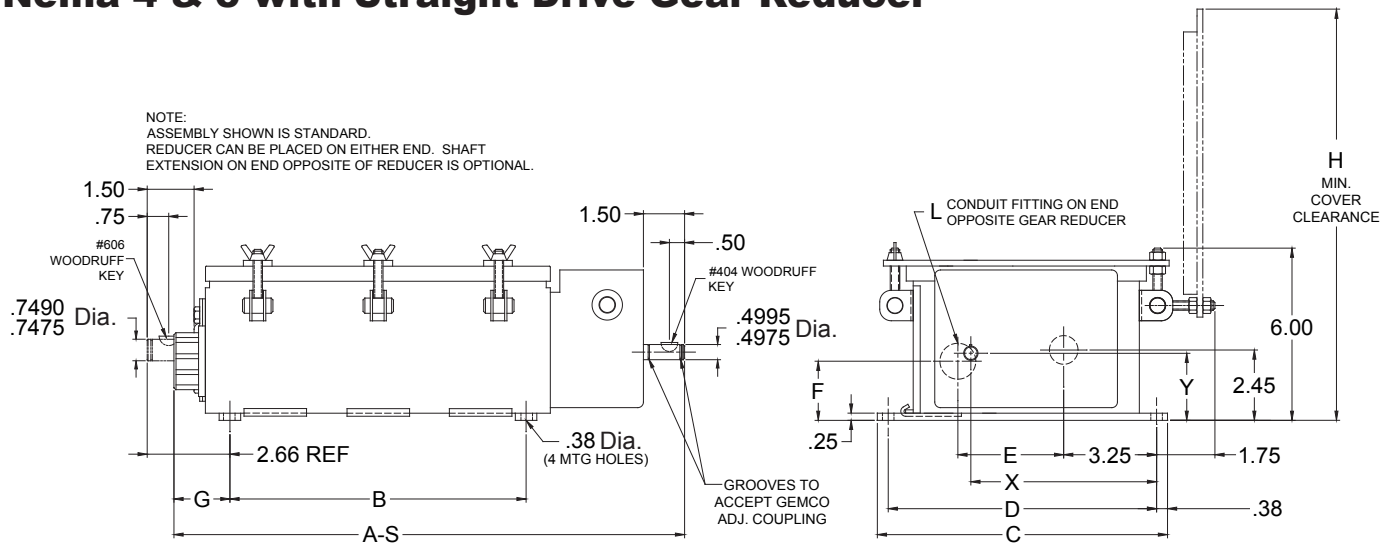

## Nema 4 & 5 with Right Angle Gear Reducer

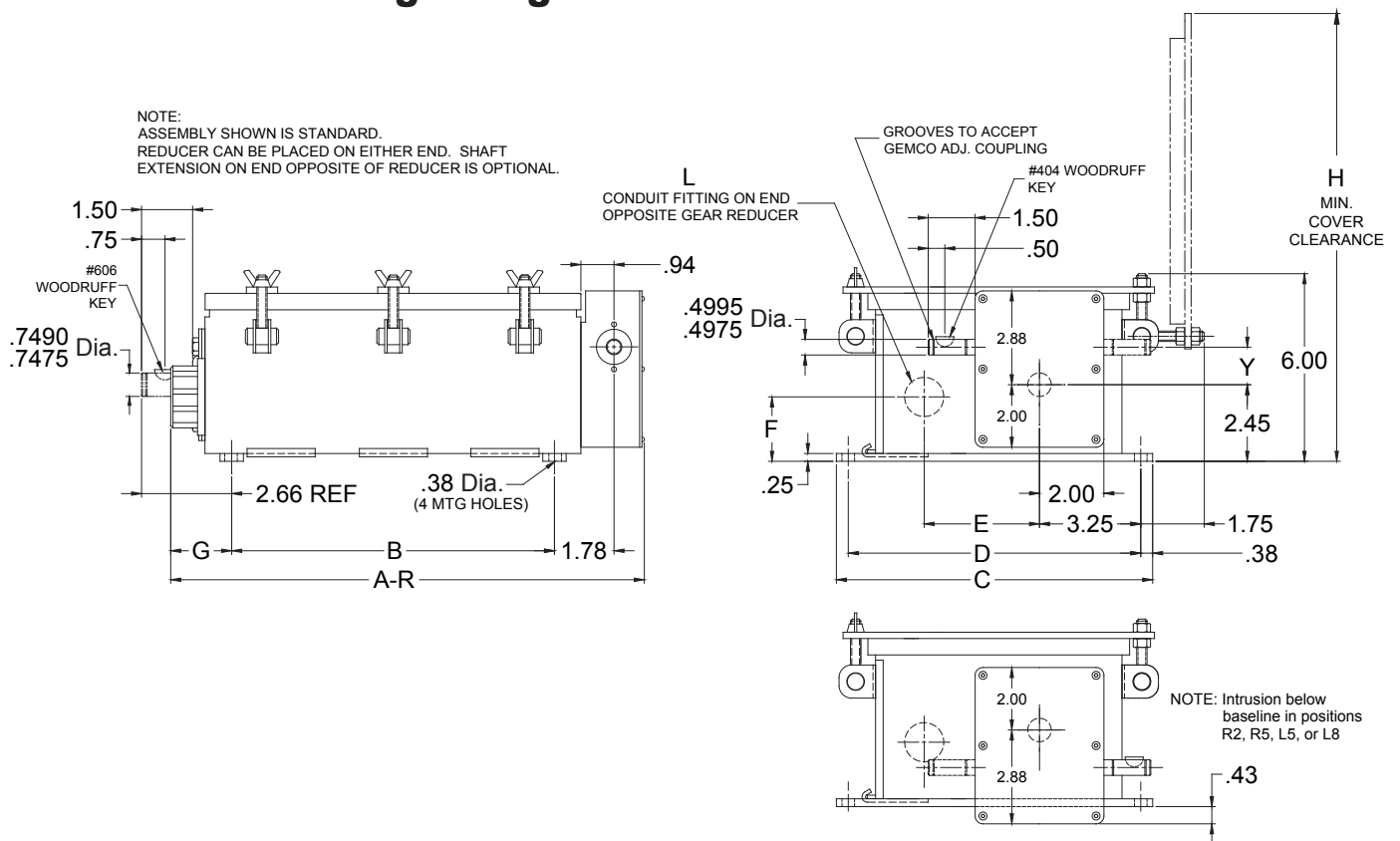



## NEMA 7 Dimensions

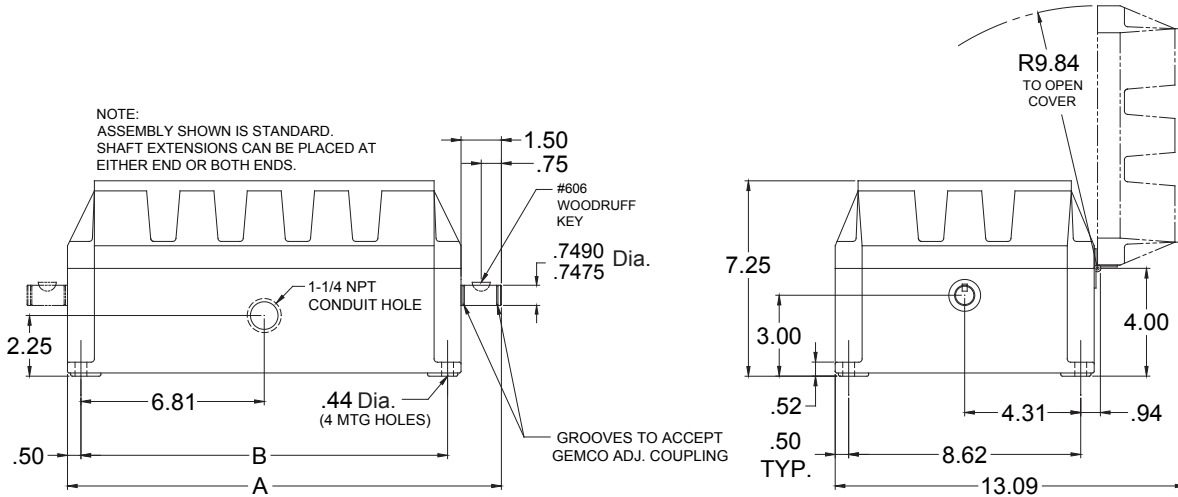

\*\*\*\*\* Need Numbers Below \*\*\*\*\*

No. of Circuits	A	A-S	A-R	B	C	D	E	F	G	L	Wt. Approx. Gross
2 to 4	9.69	12.53	9.78	5.45	10.12	9.38	3.69	2.06	1.57	.75	18 lb.
5 to 6	12.24	15.08	12.32	7.89	10.12	9.38	3.69	2.06	1.69	1.25	24 lb.
7 to 8	14.68	17.52	14.78	10.33	10.12	9.38	3.69	2.06	1.69	1.25	26 lb.
9 to 12	19.56	22.40	19.66	15.21	10.12	9.38	3.69	2.06	1.69	1.25	32 lb.
13 to 16	26.02	28.86	26.11	21.62	12.12	11.38	4.69	2.81	1.74	2.00	50 lb.
17 to 20	30.90	33.73	30.99	26.50	12.12	11.38	4.69	2.81	1.74	2.00	65 lb.
21 to 24	35.78	38.62	35.87	31.38	12.12	11.38	4.69	2.81	1.74	2.00	75 lb.
25 to 28	42.19	45.02	42.27	37.80	12.12	11.38	4.69	2.81	1.74	2.00	
29 to 32	47.07	49.91	47.15	42.66	12.12	11.38	4.69	2.81	1.74	2.00	
33 to 36	51.95	54.79	52.03	47.54	12.12	11.38	4.69	2.81	1.74	2.00	
37 to 40	56.83	59.67	56.93	52.42	12.12	11.38	4.69	2.81	1.74	2.00	

Straight Drive					
Ratio	X	Y	Ratio	X	Y
1.25:1	4.83	2.45	32:1	5.94	2.64
2:1	4.75	2.45	35:1	5.94	2.70
2.2:1	5.25	2.45	40:1	5.94	2.26
3:1	4.92	2.45	48:1	5.94	2.39
4:1	6.25	2.45	50:1	5.94	2.45
5:1	6.50	2.45	80:1	5.94	2.82
6:1	6.42	2.45	96:1	5.94	2.70
7:1	6.67	2.45	100:1	5.94	2.45
8:1	6.63	2.45	200:1	5.94	2.45
8.5:1	6.11	2.45	400:1	5.94	2.45
10:1	5.94	2.26	500:1	5.94	2.29
12:1	5.94	2.39	600:1	5.94	2.14
14:1	5.94	2.51	1:2	4.75	2.45
15:1	5.94	2.57	1:3	4.92	2.45
16:1	5.94	2.64	1:4	6.25	2.45
20:1	5.94	2.26	1:5	6.50	2.45
24:1	5.94	2.39	1:6	6.42	2.45
25:1	5.94	2.45	1:7	5.46	2.51
28:1	5.94	2.51	1:8	5.69	2.45
30:1	5.94	2.57			

Right Angle Drive			
Ratio	Y	Ratio	Y
1:1	1.00	15:1	1.250
1.2:1	1.375	16:1	1.312
1.25:1	1.125	17:1	1.368
1.33:1	1.750	18:1	1.437
1.5:1	1.250	20:1	.937
1.6:1	1.625	24:1	1.062
2:1	1.500	25:1	1.875
2.5:1	1.750	28:1	1.187
3:1	2.00	30:1	1.250
4:1	1.875	32:1	1.312
4.75:1	.906	36:1	1.437
5:1	.937	40:1	1.562
6:1	1.062	48:1	1.812
7:1	1.187	50:1	1.875
7.5:1	1.250	60:1	1.156
8:1	1.312	64:1	1.218
10:1	.937	72:1	1.344
12:1	1.062	80:1	1.469
12.5:1	1.875	96:1	1.719
14:1	1.187	100:1	1.781

**NOTE:**  
Add 4 lbs. with Right  
Angle Gear Reducer.  
Add 6 lbs. with  
Straight Drive Gear  
Reducer.

Consult factory  
for Gear Reducer  
dimensions.



## NEMA 7 with Straight Drive Gear Reducer

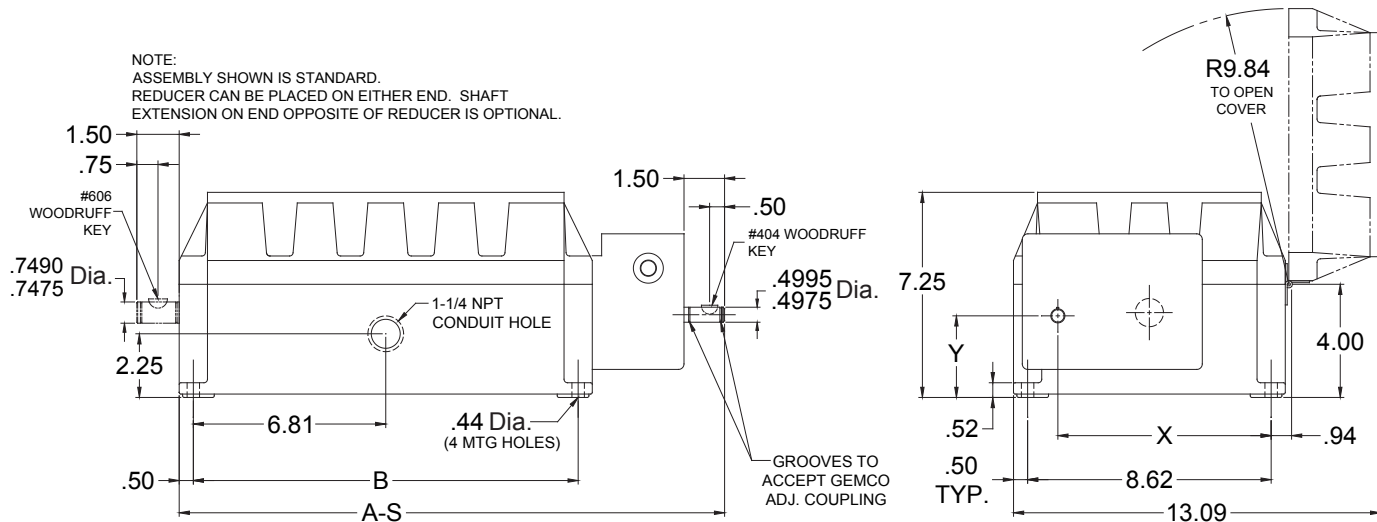

## NEMA 7 with Right Angle Gear Reducer

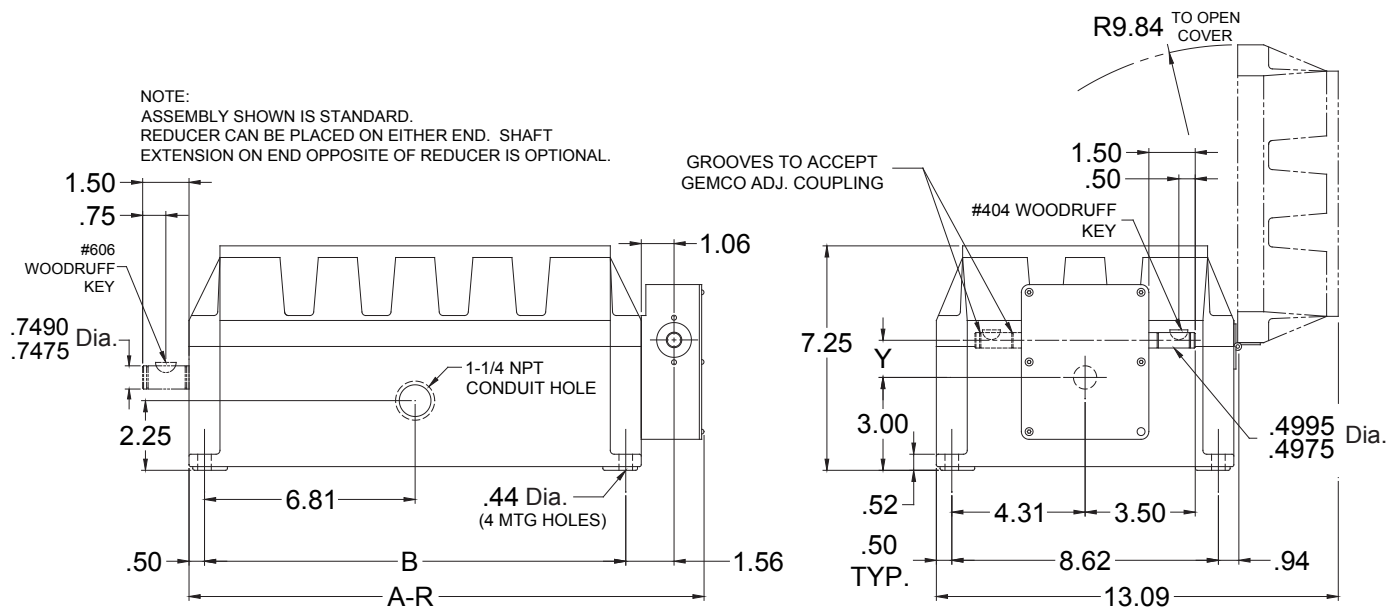



## NEMA 12 Dimensions

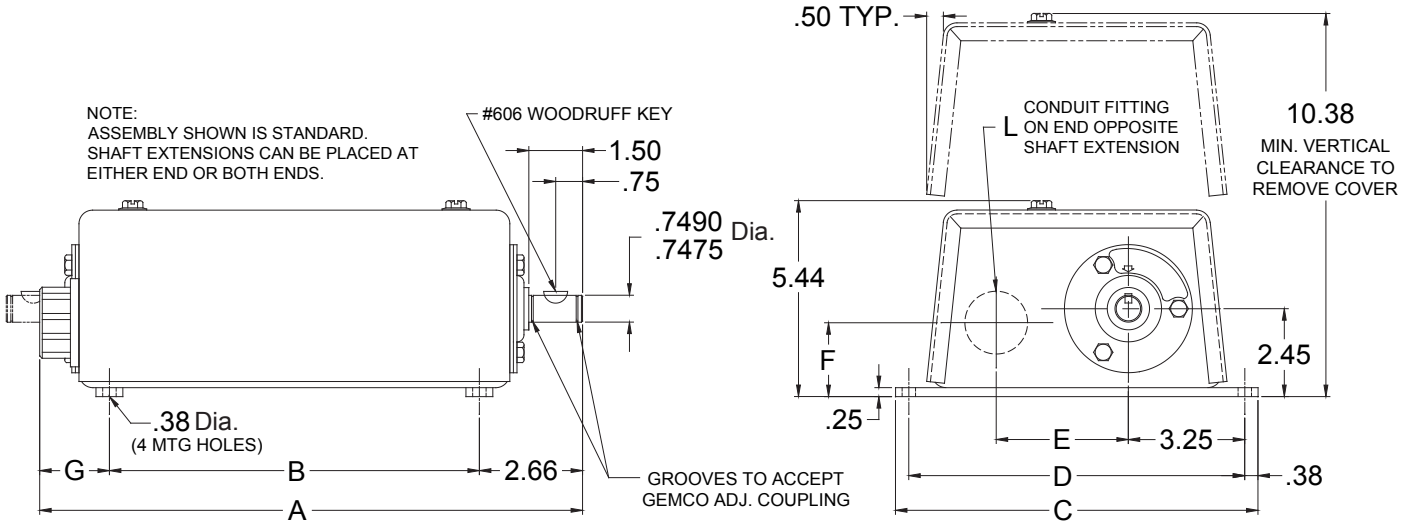

No. of Circuits	A	A-S	A-R	B	C	D	E	L	Wt. Approx. Gross
2 to 4	9.28	12.12	9.38	4.42	6.50	5.00	3.12	.75	12 lb.
5 to 6	11.72	14.56	11.82	6.86	6.50	5.00	3.12	1.25	14 lb.
7 to 8	14.16	17.00	14.26	9.30	6.50	5.00	3.12	1.25	16 lb.
9 to 12	19.04	21.88	19.14	14.18	6.50	5.00	3.12	1.25	21 lb.
13 to 16	25.45	28.29	25.55	20.60	7.00	5.50	3.40	2.00	35 lb.
17 to 20	30.33	33.17	30.43	25.48	7.00	5.50	3.40	2.00	46 lb.
21 to 24	35.21	38.05	35.31	30.36	7.00	5.50	3.40	2.00	55 lb.
25 to 28	41.62	44.46	41.72	36.76	7.00	5.50	3.40	2.00	
29 to 32	46.50	49.34	46.60	41.64	7.00	5.50	3.40	2.00	
33 to 36	51.38	54.22	51.48	46.52	7.00	5.50	3.40	2.00	
37 to 40	56.26	59.10	56.36	51.40	7.00	5.50	3.40	2.00	

Straight Drive					
Ratio	X	Y	Ratio	X	Y
1.25:1	2.71	2.07	32:1	3.82	2.26
2:1	2.63	2.07	35:1	3.82	2.32
2.2:1	3.13	2.07	40:1	3.82	1.88
3:1	2.80	2.07	48:1	3.82	2.01
4:1	4.13	2.07	50:1	3.82	2.07
5:1	4.38	2.07	80:1	3.82	2.44
6:1	4.30	2.07	96:1	3.82	2.32
7:1	4.55	2.07	100:1	3.82	2.07
8:1	4.51	2.07	200:1	3.82	2.07
8.5:1	3.99	2.07	400:1	3.82	1.91
10:1	3.82	1.88	500:1	3.82	1.76
12:1	3.82	2.01	600:1	3.82	2.07
14:1	3.82	2.13	1:2	2.63	2.07
15:1	3.82	2.19	1:3	2.80	2.07
16:1	3.82	2.26	1:4	4.13	2.07
20:1	3.82	1.88	1:5	4.38	2.07
24:1	3.82	2.01	1:6	4.30	2.07
25:1	3.82	2.07	1:7	3.34	2.13
28:1	3.82	2.13	1:8	3.57	2.07
30:1	3.82	2.19			

Right Angle Drive			
Ratio	Y	Ratio	Y
1:1	1.00	15:1	1.250
1.2:1	1.375	16:1	1.312
1.25:1	1.125	17:1	1.368
1.33:1	1.750	18:1	1.437
1.5:1	1.250	20:1	.937
1.6:1	1.625	24:1	1.062
2:1	1.500	25:1	1.875
2.5:1	1.750	28:1	1.187
3:1	2.00	30:1	1.250
4:1	1.875	32:1	1.312
4.75:1	.906	36:1	1.437
5:1	.937	40:1	1.562
6:1	1.062	48:1	1.812
7:1	1.187	50:1	1.875
7.5:1	1.250	60:1	1.156
8:1	1.312	64:1	1.218
10:1	.937	72:1	1.344
12:1	1.062	80:1	1.469
12.5:1	1.875	96:1	1.719
14:1	1.187	100:1	1.781

**NOTE:**  
Add 4 lbs. with Right Angle Gear Reducer.  
Add 6 lbs. with Straight Drive Gear Reducer.  
  
Consult factory for Gear Reducer dimensions.

## NEMA 12 with Straight Drive Gear Reducer

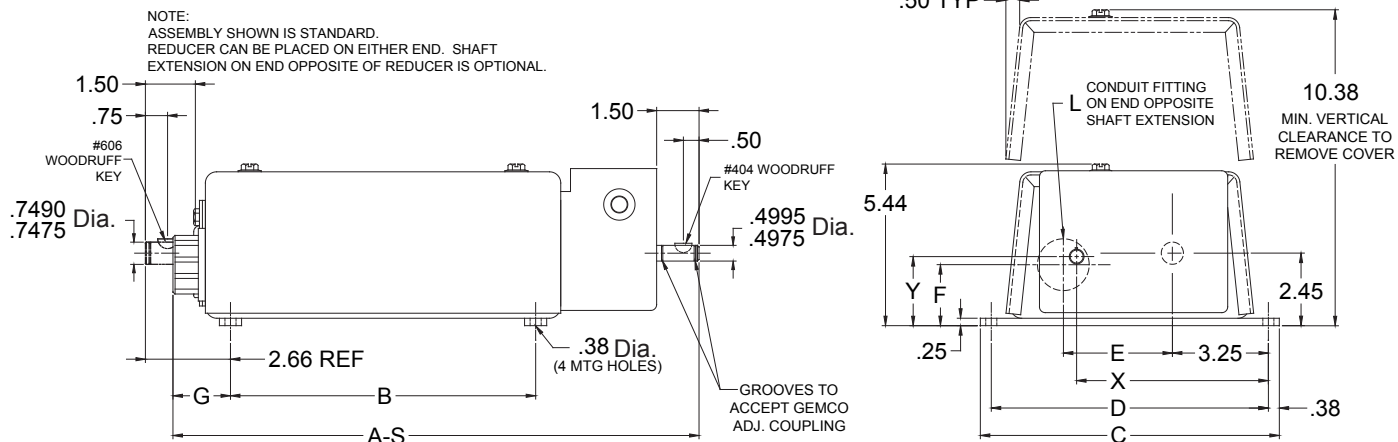

## NEMA 12 with Right Angle Gear Reducer

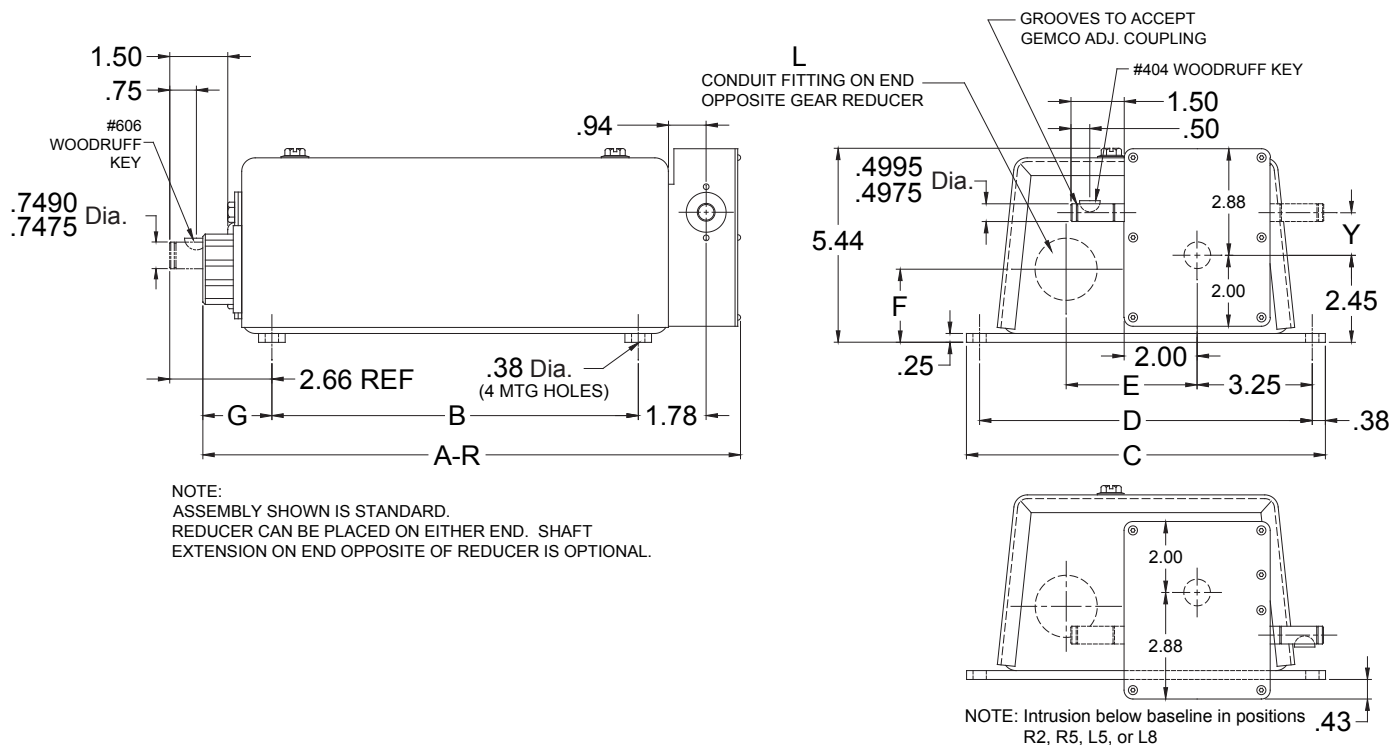



AMETEK APT Products		
	<ul style="list-style-type: none"> <li>LINEAR DISPLACEMENT TRANSDUCERS</li> <li>PLC INTERFACE PRODUCTS</li> <li>ROTARY POSITION PRODUCTS</li> <li>PROGRAMMABLE LIMIT SWITCHES</li> <li>EXTREME DUTY CABLE REEL PRODUCTS</li> <li>ROTARY LIMIT SWITCHES</li> <li>RESOLVERS</li> <li>MILL DUTY ENCLOSURES</li> <li>ULTRA HIGH SPEED PLS</li> <li>SAFETY PRODUCTS</li> </ul>	

Copyright 2005 by AMETEK AUTOMATION & PROCESS TECHNOLOGIES. All Rights Reserved. Made in the USA.



6380 Brockway Road, Peck, MI 48017  
 Phone: 810.378.5511 Toll Free: 800.325.8074  
 Fax: 810.378.5516 [www.AMETEKAPT.com](http://www.AMETEKAPT.com)

1980.C3R  
 5/05.Z11  
 2M

