

# MICRO-AMP® System

## SP100FF Fixed-field Sensor



- Optical design ensures an exact range limit, regardless of the surface reflectivity of the objects to be sensed
- Powerful infrared light source and modulated amplification provide reliable sensing of objects with low surface reflectivity
- Sensor response to background objects is completely suppressed
- Miniature size fits easily into tight areas of machines
- Works with special versions of Banner's MICRO-AMP® Series of modulated amplifiers

Model SP100FF is a fixed-field convergent mode sensor that detects objects directly by reflection of light from the object's surface. The light is sensed at two receive points and compared to define a precise limit to the maximum sensing range. Objects in the background are ignored, regardless of their surface reflectivity.

This sensing response feature makes the SP100FF an ideal choice for detecting a part or a surface that is only a small fraction of an inch in front of another surface. The SP100FF is highly reliable for semiconductor wafer sensing. Wafers of all reflectivities are sensed without mechanical or system sensitivity adjustment. Other applications include cut-to-length control, double-thickness detection, and precision edgewise. The SP100FF is an excellent choice for precise position control (e.g. as a robotic end effector).

The SP100FF works in conjunction with Banner MICRO-AMP modulated amplifier model MA3A or MPC3A. Model MA3A is powered by +10 to 30V dc and uses a model RS8 socket. Model MPC3A is powered by +5V dc and is designed for mounting directly onto PC boards.

With a typical excess gain of 100X at the peak signal point (referenced to a 90% reflectance white test card), the SP100FF has enough optical energy to reliably sense material of very low reflectivity such as nitride-coated semiconductor wafers. The typical peak signal point is 0.12 inch from the sensor face. Excess gain falls off sharply beyond the peak signal point (see excess gain curve, below).

### Theory of Operation

The SP100FF uses two photoelements that operate with the modulated amplifier in a differential mode. The photoelements are mechanically convergent with the LED light source at two different distances from the sensor face. The inner photoelement (R1) produces a positive-going pulse which turns the output of the amplifier "on". The outer photoelement (R2) produces a negative-going pulse that works to turn the amplifier "off".

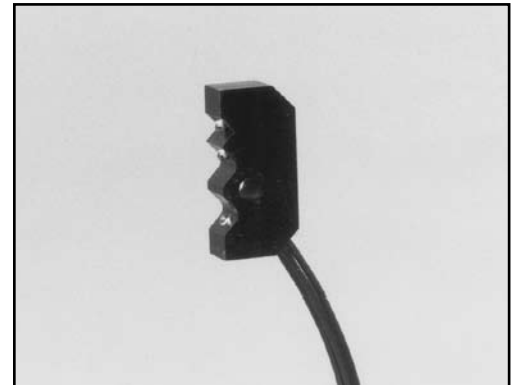

### Conceptual Drawing

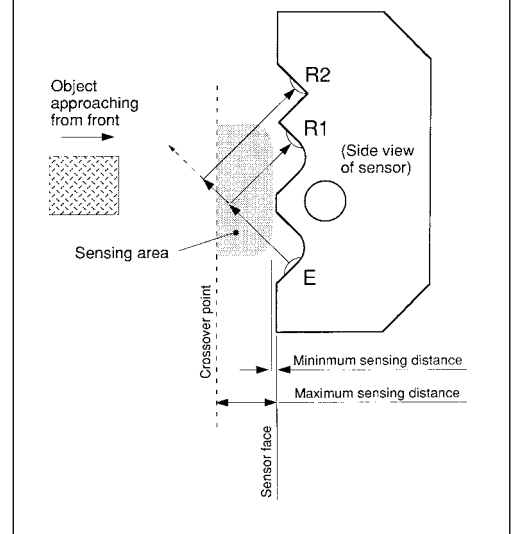

A target is sensed whenever the amount of light reaching receiver R1 is equal to or greater than the amount of light "seen" by R2. The output of the amplifier is cut off as soon as the amount of light at R2 becomes greater than at R1. The location of this "crossover point" is dictated by the geometry of the photoelement configuration, and remains the same regardless of the target's reflectivity.

Reflections even from highly-polished mirror-like surfaces are ignored if the reflections originate from beyond the crossover point. Modulated LED design offers very high excess gain at the convergent point of R1 (see excess gain curve). As a result, even objects of very low reflectivity may be sensed.

The rapid fall-off in signal strength over a very short distance (as seen in the excess gain curve) accounts for the highly repeatable distance-sensing accuracy of the SP100FF, independent of target surface reflectivity.

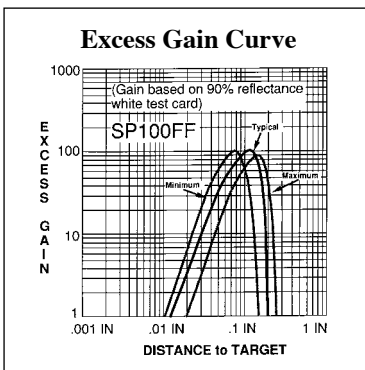

**WARNING** These photoelectric sensing devices do NOT include the self-checking redundant circuitry necessary to allow their use in personnel safety applications. A failure or malfunction can result in *either* an energized or a de-energized output condition.

Never use these products as sensing devices for personnel protection. Their use as safety devices may create an unsafe condition which could lead to serious injury or death.

Only MACHINE-GUARD and PERIMETER-GUARD Systems, and other systems so designated, are designed to meet OSHA and ANSI machine safety standards for point-of-operation guarding devices. No other Banner sensors or controls are designed to meet these standards, and they must NOT be used as sensing devices for personnel protection.

# MICRO-AMP® System

## Specifications, model SP100FF

**Crossover Point:** .15 to .25 inch (3,8 to 6,4 mm), .20 inch (5,1 mm) nominal referenced from sensor face

**Peak Signal Point:** .08 to .16 inch (2 to 4 mm), .12 inch (3 mm) nominal referenced from sensor face

**Response Speed:** a function of the amplifier (see below)

**Emitter characteristics:** infrared LED, 880nm

**Construction:** totally encapsulated, glass lenses. Black Delrin® housing; NEMA 1, 3, 4, 12, and 13.

**Operating Temperature:** 0 to 70°C (+32 to 158°F)

**Cable:** supplied with 6 feet of 4-conductor PVC-covered cable.

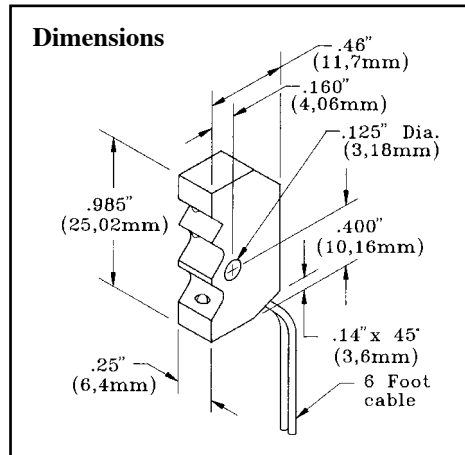

Delrin® is a registered trademark of DuPont Co.

### SP100FF Hookup to MICRO-AMP® MA3A Amplifier

**MICRO-AMP modulated amplifier model MA3A** is designed for use with the SP100FF sensor. Model MA3A has the same specifications as standard MICRO-AMP model MA3, with the exceptions of response speed and sensor hookup.

Model MA3A offers complementary *current sinking* outputs. Each output has sufficient capacity to switch small electromechanical devices, such as relays, and will directly interface logic inputs.

Connections are made using the optional RS8 socket and wiring base, or the MA3A may be mounted directly to a PC board. The sensing system is powered by +10 to 30V dc. Power supply model MPS-15 is available, and includes its own board-mounted socket for the MA3A and a built-in SPDT output relay.

Model MA3A features the patented Banner Alignment Indicator Device (AID™) signal strength indicator system\*. The SP100FF's sensitivity is adjustable via a gain potentiometer on top of the amplifier module. Circuitry is epoxy-encapsulated and protected by a tough molded VALOX® housing.

Additional information for model MA3A may be obtained from the description of standard amplifier model MA3 in Banner product data sheet P/N 03340.

VALOX® is a registered trademark of General Electric Company

\* US patent no. 4356393

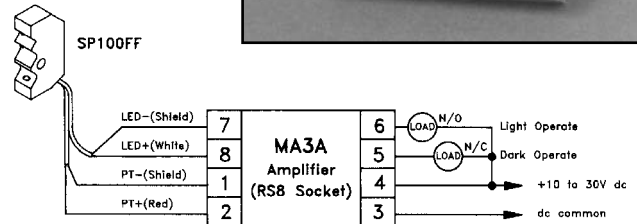
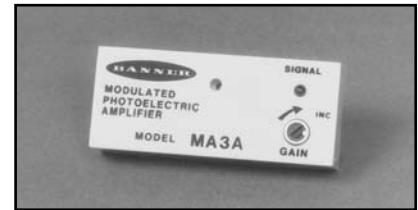

### Specifications, MICRO-AMP MA3A Amplifier

**Power Supply Requirements:** +10 to 30V dc at less than 20mA; 10% maximum ripple. Power may be obtained from Banner power supply model MPS-15, CP12C, CP12RC, or PS120-15.

**Output Configuration:** two open-collector NPN (current sinking) transistor solid-state switches, one normally open, one normally closed. 150mA maximum, each output.

**Response speed:** 2 milliseconds (typical)

**Maximum Sensor Lead Length:** 15 feet (4,5 m)

**Operating Temperature:** 0 to 70°C (+32 to 158°F)

### SP100FF Hookup to MICRO-AMP® MPC3A Amplifier

**Amplifier model MPC3A** is a modified version of standard model MPC3 (product data sheet P/N 03336). The MPC3A is configured for use with sensor model SP100FF.

Model MPC3A is a miniature "component" amplifier that is designed for mounting directly to a PC board. The MPC3A is powered by +5V dc, and outputs are conventional buffered (complementary) CMOS gates.

Specifications for model MPC3A (except for response time and hookup information) are identical to standard model MPC3. MPC3A response time is less than 1.5 milliseconds, and may be adjusted for faster response. See Banner product data sheet P/N 03336 for complete information.

