

# SSA-EB Series Emergency Stop Push Buttons

30 mm Panel Mount Electro-Mechanical Push Buttons

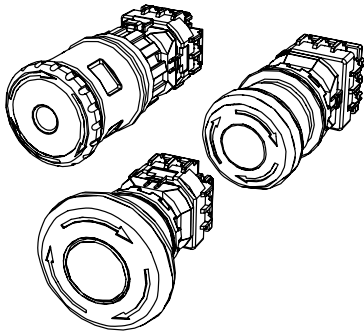

## Features



- Four styles of actuators: standard, illuminated, lockable, and illuminated lockable
- Push-to-stop, twist-to-release (standard and lockable), or pull-to-release (standard) operation per IEC60947-5-5
- Latching design complies with ISO 13850; direct (positive) opening operation per IEC 60947-5-1
- Compliant with ANSI B11.19, ANSI NFPA79, and IEC/EN 60204-1 Emergency Stop requirements
- "Safe Break Action" ensures N.C. contacts will open if the contact block is separated from the actuator
- Panel mount though 30 mm mounting hole
- "Emergency Stop" legend optional

Models SSA-EB... series are "mushroom-style" electro-mechanical emergency stop push buttons. These buttons mount through a 30 mm hole in an enclosure. When the button is armed, the switch's safety contacts (N.C.) are closed and its monitoring contacts (N.O.), if present, are open. When the button is pushed, the switch's safety contacts open and the monitoring contacts close. The contacts remain in this condition until they are manual rearmed. The standard 40 mm and 60 mm actuators can be rearmed by pulling or twisting clockwise the red actuator. The lockable 44 mm actuator can be rearmed only by twisting the actuator clockwise. Do not pull the actuator while twisting or the switch may be damaged, causing a malfunction or operational failure. The illuminated models provide a RED indication within the face of the button that allows for easy identification of a pushed/actuated button.

SSA-EB1M... series padlock-style lockable emergency stop push buttons are intended to prevent unauthorized or accidental resetting of a pushed/latched button. The SSA-EB1M... series are not to be used as an energy isolating device or as the sole means of complying with Lockout/Tagout or with the requirements of the isolation of hazardous energy (see OSHA 29CFR1910.147, ANSI Z244.1, CSA Z460, ISO 14118). The locking feature can be used to provide supervisory/personal control and provide an additional safety measure(s) to reduce the likelihood of inadvertent arming and energization of the emergency stop circuit.

## Models

Non-Illuminated Models			
Standard 40 mm	Standard 60 mm	Lockable 44 mm	E-Stop Contact
SSA-EB1P-02	SSA-EB2P-02	SSA-EB1MP-02	2 N.C.
SSA-EB1P-04	SSA-EB2P-04	SSA-EB1MP-04	4 N.C.
SSA-EB1P-11	SSA-EB2P-11	SSA-EB1MP-11	1 N.C. / 1 N.O.
SSA-EB1P-13	SSA-EB2P-13	SSA-EB1MP-13	3 N.C. / 1 N.O.
SSA-EB1P-22	SSA-EB2P-22	SSA-EB1MP-22	2 N.C. / 2 N.O.
Illuminated Models			
Standard 40 mm	Lockable 44 mm	LED	E-Stop Contact
SSA-EB1PL1-02	SSA-EB1ML1P-02	Per Hookup	2 N.C.
SSA-EB1PL1-04	SSA-EB1ML1P-04	Per Hookup	4 N.C.
SSA-EB1PL1-11	SSA-EB1ML1P-11	Per Hookup	1 N.C. / 1 N.O.
SSA-EB1PL1-13	SSA-EB1ML1P-13	Per Hookup	3 N.C. / 1 N.O.
SSA-EB1PL1-22	SSA-EB1ML1P-22	Per Hookup	2 N.C. / 2 N.O.
SSA-EB1PL2-12	SSA-EB1ML2P-12	PUSH ON	2 N.C. / 1 N.O.

## Important... Read this before proceeding!

The user is responsible for satisfying all local, state, and national laws, rules, codes, and regulations relating to the use of this product and its application. Banner Engineering Corp. has made every effort to provide complete application, installation, operation, and maintenance instructions. Please direct any questions regarding the use or installation of this product to the factory applications department at the telephone numbers or address found at <http://www.bannerengineering.com>.

The user is responsible for making sure that all machine operators, maintenance personnel, electricians, and supervisors are thoroughly familiar with and understand all instructions regarding the installation, maintenance, and use of this product, and with the machinery it controls. The user and any personnel involved with the installation and use of this product must be thoroughly familiar with all applicable standards, some of which are listed within the specifications. Banner Engineering Corp. makes no claim regarding a specific recommendation of any organization, the accuracy or effectiveness of any information provided, or the appropriateness of the provided information for a specific application.



### WARNING: Not a Safeguarding Device

**An Emergency Stop Device is not considered a safeguarding device because it requires an overt action by an individual to stop machine motion or hazards.**

(A safeguarding device limits or eliminates an individual's exposure to a hazard *without action by the individual or others.*) Because an individual must actuate the device for it to function, these devices do not fit the definition of a safeguarding device and cannot be substituted for required safeguarding. Refer to the relevant standards to determine those requirements.

## Emergency Stop Considerations

ANSI NFPA 79, ANSI B11.19, IEC/EN 60204-1, and ISO 13850 specify emergency stop requirements, including the following:

- Emergency-stop push buttons shall be located at each operator control station and at other operating stations where emergency shutdown is required.
- Stop and emergency-stop push buttons shall be continuously operable and readily accessible from all control and operating stations where located. Do not mute or bypass E-stop buttons.
- Actuators of emergency-stop devices shall be colored red. The background immediately around the device actuator shall be colored yellow (where possible). The actuator of a push-button-operated device shall be of the palm or mushroom-head type.
- The emergency-stop actuator shall be a self-latching type.



### WARNING: Emergency Stop Functions

**Do not mute or bypass any Emergency Stop device.** ANSI B11.19, ANSI NFPA79 and IEC/EN 60204-1 require that **the Emergency Stop function remain active at all times.**



### WARNING: Multiple Switching Devices

**Whenever two or more devices are connected to the same safety module (controller):**

- **Contacts of the corresponding pole of each switch must be connected together in series. Never connect the contacts of multiple switches in parallel.** Such a parallel connection defeats the switch contact monitoring ability of the Module and creates an unsafe condition which could result in serious injury or death.
- **Each device must be individually actuated (engaged), then released (or re-armed) and the safety module reset.** This allows the module to check each switch and its wiring to detect faults.

This check must be performed during the prescribed checkouts. **Failure to test each device individually in this manner could result in undetected faults and create an unsafe condition which could result in serious injury or death.**

## Installation and Maintenance

The device must not be affected by environmental conditions. **Install the device so that operation is not impeded, but should be protected against inadvertent operation** (for example, accidental actuation by being bumped or leaned against). Do not operate the switch using a tool. Do not expose the switch to excessive shocks and vibrations, otherwise the switch may be deformed or damaged, causing malfunction or operation failure. See *Dimensions* on page 8.

Electrical installation must be made by qualified personnel<sup>1</sup> and must comply with NEC (National Electrical Code), ANSI/NFPA 79 or IEC/EN 60204-1, and all applicable local standards. It is not possible to give exact wiring instructions for a device that interfaces to a multitude of machine control configurations. The following is general in nature; it is recommended to perform a risk assessment to ensure appropriate application, interfacing/hookup, and risk reduction (see ISO 12100 or ANSI B11.0).

For SSA-EB1M... series padlock-style lockable emergency stop push buttons, make sure that an applicable padlock and hasp is used. The total weight of the padlock and hasp must not exceed 1500 g (3.3 lbs) or the switch may malfunction or fail.

### Removing and Installing the Contact Block and Panel Mounting

#### Remove the Contact Block

1. Arm (reset) the actuator (button). Do not attempt to remove the contact block while the actuator is latched (pushed), or the switch may be damaged.
2. Grip the beveled surfaces at the corners of the yellow bayonet ring and pull the ring toward the contact block until the latch pin clicks.



**Tip:** If the switch is not installed, place the contact block against the base of the index finger and grip the bayonet ring with the thumb, index finger, and middle finger, then squeeze until the click is heard.

3. Rotate the contact block counterclockwise and pull out to remove the contact block. Do not use excessive force when removing the contact block, or the switch may be damaged.



#### NOTE:

- For illuminated pushbuttons, the LED lamp is built into the contact block. When removing the contact block, pull the contact block straight to prevent damage to the LED lamp. Do not use excessive force or the LED lamp may be damaged and fail to light.
- When the contact block is removed, the monitor contact (normally open contact) is closed.

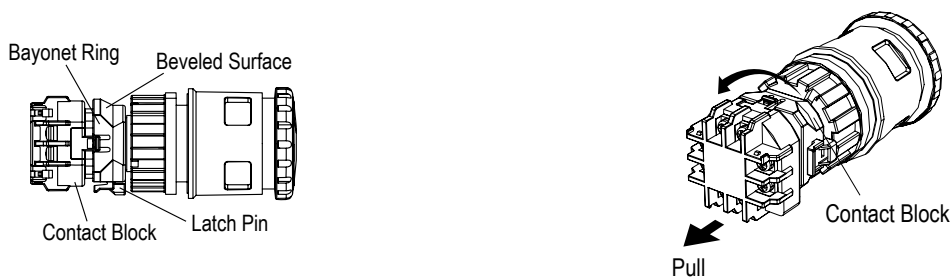

<sup>1</sup> A Qualified Person possesses a recognized degree or certificate or has extensive knowledge, training, and experience to solve problems relating to the emergency stop installation.

## Panel Mounting

1. Remove the contact block and the M30 jam nut from the actuator and verify that the rubber gasket is in place.
2. Align the anti-rotation key on the bezel with the keyway (notch) in the panel.
3. Insert the actuator into the hole from the front of the panel, and tighten the M30 jam nut using wrench SSA-EB1-LRW or SSA-EB1-LRTW to a maximum torque of 2.5 N•m (1.8 ft-lbs).



### NOTE:

- The allowable panel thickness is 1 mm to 5 mm for SSA-EB1P... and 1 mm to 6 mm for SSA-EB1M....
- Banner recommends that the anti-rotation key/keyway is placed at the top of the hole (0° versus 90° or 180°) so the word "TOP" on the contact block and actuator is on the top so that the terminal label is easier to read.
- If using ESLP1-30/60-.. Plastic Emergency Stop legend, remove the anti-rotation projection on the legend using pliers, and then install the legend onto the actuator before inserting it into the hole.

## Install the Contact Block

1. Arm (reset) the actuator (button). Do not attempt to install the contact block while the actuator is latched (pushed), or the switch may be damaged.
2. Align the small ▼ mark on the edge of the actuator with the small ▲ mark on the yellow bayonet ring. The contact block (TOP LOCK) should be turned approximately 45° counterclockwise from the anti-rotation key/keyway on the bezel.
3. Hold the black contact block (not the yellow bayonet ring), and slide the contact block onto the actuator. Push until the actuator is fully inserted into the contact block (the bayonet ring will compress and motion will stop).



**NOTE:** If not installed on a panel, press on the actuator's bezel (not the button).

4. Turn the contact block clockwise until the yellow bayonet ring pops into position and clicks. When properly seated, the contact block cannot be turned or pulled.

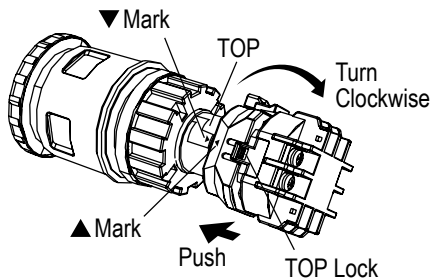

## Hookups

Non-Illuminated	E-Stop Contact	Hookup	Illuminated	E-Stop Contact	Hookup
SSA-EB1P-02 SSA-EB1MP-02	2 N.C.		SSA-EB1PL1-02 SSA-EB1ML1P-02	2 N.C.	

Non-Illuminated	E-Stop Contact	Hookup	Illuminated	E-Stop Contact	Hookup
SSA-EB1P-04 SSA-EB1MP-04	4 N.C.		SSA-EB1PL1-04 SSA-EB1ML1P-04	4 N.C.	
SSA-EB1P-11 SSA-EB1MP-11	1 N.C. / 1 N.O.		SSA-EB1PL1-11 SSA-EB1ML1P-11	1 N.C. / 1 N.O.	
SSA-EB1P-13 SSA-EB1MP-13	3 N.C. / 1 N.O.		SSA-EB1PL1-13 SSA-EB1ML1P-13	3 N.C. / 1 N.O.	
SSA-EB1P-22 SSA-EB1MP-22	2 N.C. / 2 N.O.		SSA-EB1PL1-22 SSA-EB1ML1P-22	2 N.C. / 2 N.O.	
			SSA-EB1PL2-12 SSA-EB1ML2P-12 (Push ON LED)	2 N.C. / 1 N.O.	

### Applicable Crimping Terminal

Ring Terminal

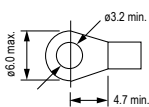

Spade Terminal

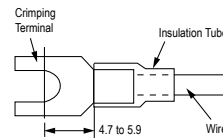
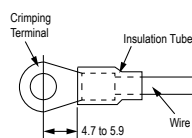
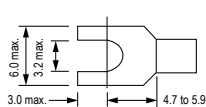

Solid Wire

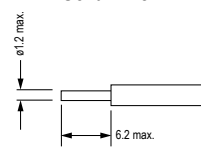

Banner recommends the use of crimp terminals with stranded wire or solid core wire to prevent short circuits between terminals. Ensure that the insulation tube is installed on crimp terminals.

### Installing and Removing the Terminal Cover

Install the SSA-EB1-TC Terminal Cover

1. Align the TOP mark on the SSA-EB1-TC terminal cover with the TOP mark on the contact block.
2. Place the two projections on the bottom of the contact block into the slots in the SSA-EB1-TC terminal cover.

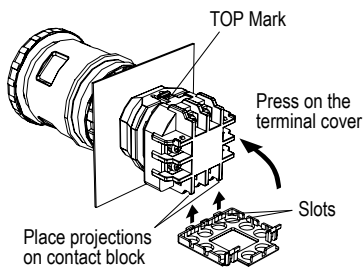

3. Press the SSA-EB1-TC terminal cover toward the contact block.

### Remove the SSA-EB1-TC Terminal Cover

1. Pull out the two latches on the top of the SSA-EB1-TC terminal cover. Do not exert excessive force on the latches, or the latches may break.

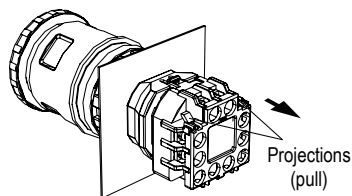

2. Remove the SSA-EB1-TC terminal cover.

### Install the IP20 Fingersafe SSA-EB1-FSTC Terminal Cover

After installation, the SSA-EB1-FSTC terminal cover cannot be removed.

With the SSA-EB1-FSTC terminal cover installed, crimping terminals cannot be used. Use solid wires.

The SSA-EB1-FSTC terminal covers cannot be installed after wiring.

Make sure that the SSA-EB1-FSTC terminal cover is securely installed. IP20 cannot be achieved when installed loosely, and electric shocks may occur.

1. Align the TOP mark on the cover with the TOP mark on the contact block.
2. Press the cover toward the contact block.

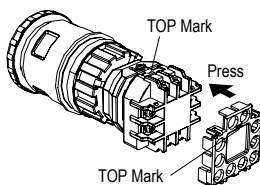

#### **WARNING: Shock Hazard and Hazardous Energy**

**Always disconnect power from the safety system (for example, device, module, interfacing, etc.) and the machine being controlled before making any connections or replacing any component.**

Electrical installation and wiring must be made by Qualified Personnel and must comply with the relevant electrical standards and wiring codes, such as the NEC (National Electrical Code), ANSI NFPA79, or IEC 60204-1, and all applicable local standards and codes.

**Lockout/tagout procedures may be required.** Refer to OSHA 29CFR1910.147, ANSI Z244-1, ISO 14118, or the appropriate standard for controlling hazardous energy.

## Specifications

### Button/Locking Collar

Polyamide/Aluminum

### Operating Temperature

Non-illuminated: -25 to +60°C (-13 to +140°F)

Illuminated: -25 to +55°C (-13 to +131°F)

### Environmental Rating

Actuator: IP65 (IEC60529)

Terminal: IP20 with SSA-EB1-FSTC installed

### Operating Humidity

45% to 85% RH (no condensation)

### Insulation Resistance

100MΩ minimum (500V DC megger)

### Impulse Withstand Voltage

2.5kV

### Pollution Degree

3

### Output Configuration

See [Installation and Maintenance](#) on page 3

### Overvoltage Category

II

### Contact Material/Bounce<sup>2</sup>

Gold plated silver / 20 ms

### Electrical Life

100,000 operations minimum, 250,000 operations minimum at 24V AC/DC, 100mA

### Mechanical Life

250,000 operations

### Shock Resistance

**Operating extremes:** 150 m/s<sup>2</sup> (15G)

### Vibration Resistance

**Operating extremes:** 10 to 500Hz, amplitude 0.35 mm acceleration 50 m/s<sup>2</sup>

### LED Color

Red (The LED is built into the contact block and cannot be replaced)

### LED Voltage/Maximum Current

24V ac/dc ±10%, 15 mA

### Total Weight of Padlock and Hasp (SSA-EB1M... only)

1500g (3.3 lb) max.

### Electrical Rating

**Minimum load:** 1 mA at 5V ac/dc

**Maximum Rated Load:** See table

**UL Applications:** 1.5A at 250V ac, 1A at 30V dc (pilot duty)

**CE Applications:** AC-15: 1.5A at 250V ac, DC-13: 1A at 30V dc

### Rated Insulation Voltage (Ui)

250V

### Rated Current (Ith)

5A

### B10d

100,000 (based on ISO13849-1(2006))

### Terminals

M3 screw terminal (terminal cover included)

Recommended Torque: 0.6 to 1.0 N•m (5.3 to 8.8 in-lbf)

Allowable Wire: 0.75 to 1.25 mm<sup>2</sup> (18 to 16 AWG)

### Design Standards

Compliant with EN/IEC 60497-1 / -5-1, ISO 13850, ANSI B11.19, ANSI NFPA79, IEC 60204-1

### Date code format (U.S. Standard Format)

**YYWWX:** 2-digit year, 2-digit week, "X" internal code

### Certifications



### Rated Operating Voltage (Ue) and Current

Safety Contact (N.C.)		30V	125V	250V
AC 50/60 Hz	Resistive Load (AC-12)	-	5A	3A
	Inductive Load (AC-15)	-	3A	1.5A
DC	Resistive Load (DC-12)	2A	0.4A	0.2A
	Inductive Load (DC-13)	1A	0.22A	0.1A

<sup>2</sup> When the button is reset, the normally closed contacts will chatter. When pressing the button, the normally open contacts will chatter. When designing a control circuit, take the contact chatter time into consideration. Do not expose the switch to external shocks, otherwise the contacts will bounce.

Monitor Contacts (N.O.)		30V	125V	250V
AC 50/60 Hz	Resistive Load (AC-12)	-	1.2A	0.6A
	Inductive Load (AC-14)	-	0.6A	0.3A
DC	Resistive Load (DC-12)	2A	0.4A	0.2A
	Inductive Load (DC-13)	1A	0.22A	0.1A

The operating current is classified according to JIS C 8201-5-1-1999 making and breaking capacities and are measured at resistive/inductive load types specified in IEC 60947-5-1. See "Electrical Rating" above for specific model and UL/CE maximum ratings.

## Checkout

At machine set up, a *Designated Person*<sup>3</sup> should test each emergency stop push button for proper machine shutdown response. A *Designated Person* should check the emergency stop buttons for proper operation, physical damage, button looseness, and excessive environmental contamination. This should take place on a periodic schedule determined by the user, based on the severity of the operating environment and the frequency of switch actuations. Adjust, repair, or replace components as needed. If inspection reveals contamination on the switch, thoroughly clean the switch and eliminate the cause of the contamination. Replace the switch and/or appropriate components when any parts or assemblies are damaged, broken, deformed, or badly worn; or if the electrical/mechanical specifications (for the environment and operating conditions) have been exceeded. **Always test the control system for proper functioning** under machine control conditions after performing maintenance, replacing the emergency stop device, or replacing any component of the device.

## Dimensions

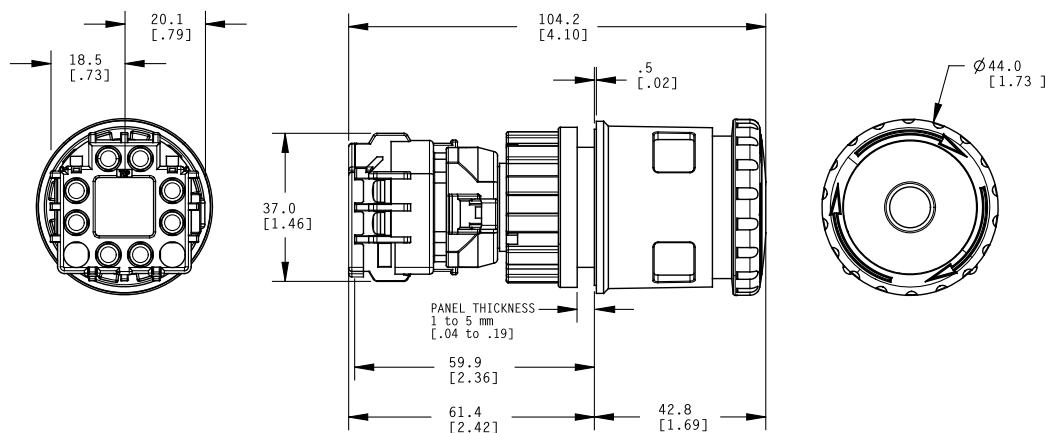

<sup>3</sup> A *Designated Person* is identified in writing by the employer as being appropriately trained to perform a specified checkout procedure. A *Qualified Person* possesses a recognized degree or certificate or has extensive knowledge, training, and experience to solve problems relating to the emergency stop installation.



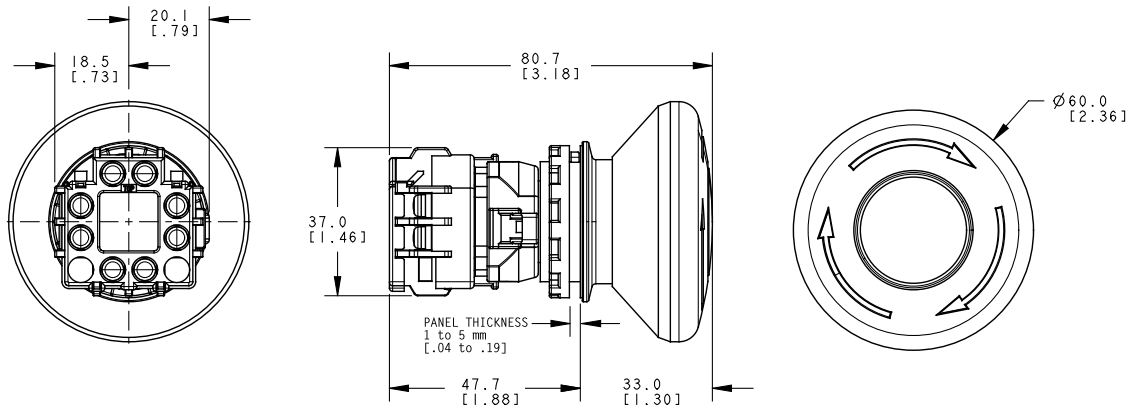
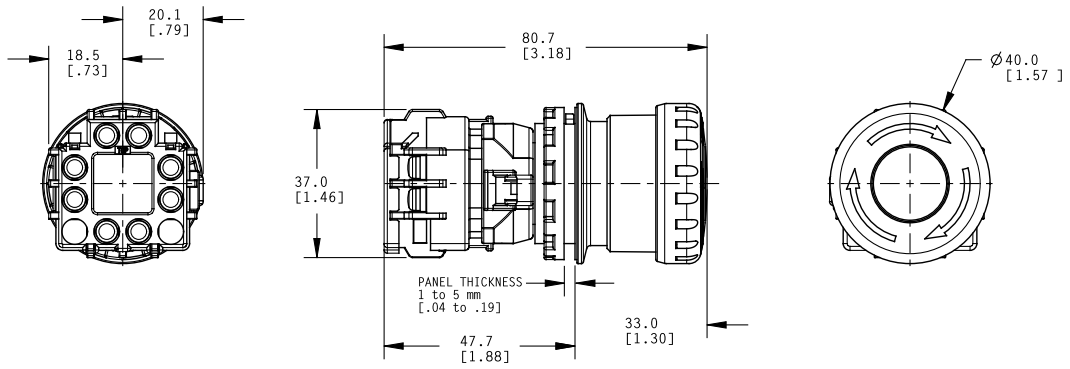

a	b	c	d
7 mm max	19 mm max	39 mm min	15 mm min <sup>4</sup>

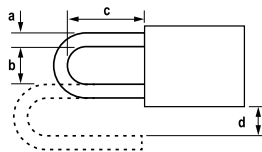

<sup>4</sup> Dimension d is 6 mm or more when attaching a padlock from the side of a switch

## Mounting Hole Layout

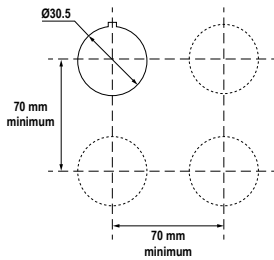

The values are the minimum dimensions for mounting with other  $\varnothing$  30 mm push buttons. For other control units of different sizes and styles, determine the values according to the dimensions, operation, and wiring convenience.

For padlock-style lockable emergency stop push buttons, determine the values according to the size and number of padlocks and hasp.

## Accessories



**NOTE:** Actuators and contact blocks (including LED indicators) are only available as complete units and are not sold separately.

### SSA-EB1-FSTC

IP20 Finger-safe terminal cover

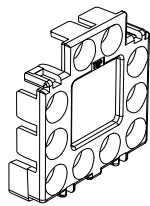

### SSA-EB1-TC

Standard terminal cover (supplied)

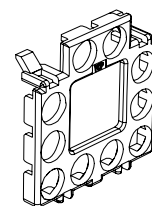

### SSA-EB1-LRW

Jam nut wrench



### SSA-EB1-LRTW

Jam nut twist wrench

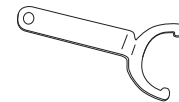

### ESLP1-30/60-NW

- E-Stop Legend, Plastic
- Blank
- 60 mm diameter (OD)
- 30 mm hole

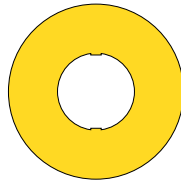

### ESLP1-30/60

- E-Stop Legend, Plastic
- "Emergency Stop"
- 60 mm diameter (OD)
- 30 mm hole

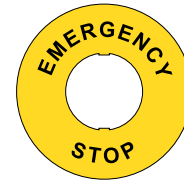

### ESL-41/60 (1 each)

#### ESL-41/60-10 (10 each)

- E-Stop Legend, Label
- "EMERGENCY STOP"
- 60 mm diameter (OD)
- 41 mm hole for application around SSA-EB1P...



### ESL-41/60-ENES (1 each)

#### ESL-41/60-ENES-10 (10 each)

- E-Stop Legend, Label
- "EMERGENCY STOP - PARADA DE EMERGENCIA"
- 60 mm diameter (OD)
- 41 mm hole for application around SSA-EB1P...



**ESL-44/70 (1 each)**

**ESL-44/70-10 (10 each)**

- E-Stop Legend, Label
- “EMERGENCY STOP”
- 70 mm diameter (OD)
- 44 mm hole for application around SSA-EB1M...



## U.S. Application Standards

ANSI B11.0 Safety of Machinery; General Requirements and Risk Assessment

ANSI B11.19 Performance Criteria for Safeguarding

ANSI NFPA 79 Electrical Standard for Industrial Machinery

## International/European Standards

ISO 12100 Safety of Machinery – General Principles for Design — Risk Assessment and Risk Reduction

ISO 13850 (EN 418) Emergency Stop Devices, Functional Aspects – Principles for Design

IEC 62061 Functional Safety of Safety-Related Electrical, Electronic and Programmable Control Systems

ISO 13849-1 (EN 954-1) Safety-Related Parts of Control Systems

IEC 60204-1 Electrical Equipment of Machines Part 1: General Requirements

IEC 60947-1 Low Voltage Switchgear – General Rules

IEC 60947-5-1 Low Voltage Switchgear – Electromechanical Control Circuit Devices

IEC 60947-5-5 Low Voltage Switchgear – Electrical Emergency Stop Device with Mechanical Latching Function

## EC Declaration of Conformity (DOC)

Banner Engineering Corp. herewith declares that the **SSA-EB1.. Emergency Stop Push Buttons** are in conformity with the provisions of the Machinery Directive (Directive 2006/42/EC) and all essential health and safety requirements have been met. For more information, visit <http://www.bannerengineering.com/>.

## Banner Engineering Corp Limited Warranty

Banner Engineering Corp. warrants its products to be free from defects in material and workmanship for one year following the date of shipment. Banner Engineering Corp. will repair or replace, free of charge, any product of its manufacture which, at the time it is returned to the factory, is found to have been defective during the warranty period. This warranty does not cover damage or liability for misuse, abuse, or the improper application or installation of the Banner product.

**THIS LIMITED WARRANTY IS EXCLUSIVE AND IN LIEU OF ALL OTHER WARRANTIES WHETHER EXPRESS OR IMPLIED (INCLUDING, WITHOUT LIMITATION, ANY WARRANTY OF MERCHANTABILITY OR FITNESS FOR A PARTICULAR PURPOSE), AND WHETHER ARISING UNDER COURSE OF PERFORMANCE, COURSE OF DEALING OR TRADE USAGE.**

This Warranty is exclusive and limited to repair or, at the discretion of Banner Engineering Corp., replacement. **IN NO EVENT SHALL BANNER ENGINEERING CORP. BE LIABLE TO BUYER OR ANY OTHER PERSON OR ENTITY FOR ANY EXTRA COSTS, EXPENSES, LOSSES, LOSS OF PROFITS, OR ANY INCIDENTAL, CONSEQUENTIAL OR SPECIAL DAMAGES RESULTING FROM ANY PRODUCT DEFECT OR FROM THE USE OR INABILITY TO USE THE PRODUCT, WHETHER ARISING IN CONTRACT OR WARRANTY, STATUTE, TORT, STRICT LIABILITY, NEGLIGENCE, OR OTHERWISE.**

Banner Engineering Corp. reserves the right to change, modify or improve the design of the product without assuming any obligations or liabilities relating to any product previously manufactured by Banner Engineering Corp.