



MINI-BEAM® SM2A312DBZ and SM2A312W

Self-contained AC-operated Wide-angle Diffuse Mode Proximity Sensors



- Compact, modulated, self-contained infrared diffuse proximity mode sensors for 24-240V ac operation
- SM2A312W wide-angle (divergent) diffuse mode sensor, 125 mm (5") range; ideal for close-range sensing of transparent or translucent objects, or objects with small profile
- SM2A312DBZ: wide-angle diffuse mode sensor, 300 mm (12") range
- Both models have clear acrylic opto-element covers to meet FDA food-processing application requirements
- Switch-selectable for light operate or dark operate
- SPST SCR solid-state output switches up to 300mA; low leakage current and saturation voltage
- Rugged, epoxy-encapsulated construction: meets NEMA 4X; IEC IP67

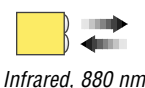
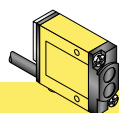

MINI-BEAM Diffuse Mode

Models	Range	Cable*	Supply Voltage	Output Type	Excess Gain	Beam Pattern
					Performance based on 90% reflectance white test card	
SM2A312DBZ SM2A312DBZQD	300 mm (12")	2 m (6.5') 3-Pin Micro QD	24-240V ac	SPST Solid-state 2-Wire		
SM2A312W SM2A312WQD	125 mm (5")	2 m (6.5') 3-Pin Micro QD	24-240V ac	SPST Solid-state 2-Wire		

*NOTES:

- 9 m (30') cables are available by adding suffix "W/30" to the model number of any cabled sensor (e.g. SM2A312DBZ W/30).
- A 150 mm (6") long pigtail cable with attached QD connector is available by adding suffix "QDP" to the model number of any MINI-BEAM sensor (e.g. SM2A312DBZQDP). See page 5 for more information.
- A model with a QD connector requires an accessory mating cable. See page 6 for more information.

MINI-BEAM® Sensors - SM2A312DBZ and SM2A312W

MINI-BEAM Installation and Alignment

Proper operation of a SM2A312W or SM2A312DBZ sensor requires that it be mounted securely and aligned properly. The wide-angle optics of these sensors makes sensor alignment very forgiving.

- 1) Begin with the sensor at the desired distance from the object to be sensed, and at the approximate position where it will be mounted. Any background should be as far behind the object as possible (at least three times the sensor-to-object distance), and as dark in color as possible, compared to the object. Ideally, the object should present its largest reflective surface to the sensor.
- 2) Switch the sensor to light operate mode (see below). Apply power to the sensor, and advance the 15-turn Gain control to maximum (clockwise end of rotation). If the sensor is “seeing” its reflected light, the sensor alignment LED should be ON. Move the sensor up-down-right-left (include angular rotation) to find the center of the movement zone within which the LED remains lit. Reducing the Gain setting (if necessary) will reduce the size of the movement zone and make more precise alignment possible.
- 3) Repeat the alignment motions after each Gain reduction. When alignment is optimized, mount the sensor solidly in that position. Increase the Gain setting to maximum. Test the system by removing the object from the sensing position. The Alignment LED indicator should go OFF. If the LED indicator does not go OFF, the sensor is reacting to light reflected from a background surface. Reduce the Gain setting until the Alignment indicator goes OFF, plus two additional full turns. Again place the object in the sensing position. If the Alignment indicator does not come ON, the sensor is receiving as much or more light energy from the background as from the object. Consider the following alternatives:
 - a) move the sensor closer to the object and reduce the sensitivity (gain);
 - b) reduce background reflectivity by painting the background with flat-black paint, or by scuffing the background or cutting a hole through it;
 - c) tilt the sensor or the background so that the sensing beam is not perpendicular to the background.

Light/Dark Operate Selection:

- Turn switch *fully* clockwise for light operate (sensor outputs conduct when object is present).
- Turn switch *fully* counterclockwise for dark operate (sensor outputs conduct when object is absent).

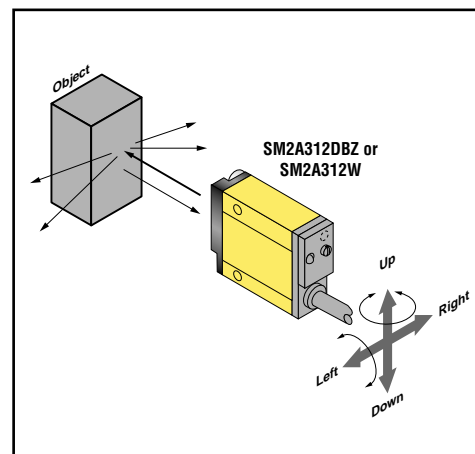

Figure 1. Diffuse mode alignment

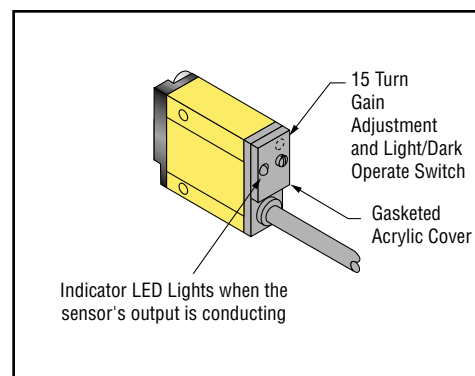



Figure 2. SM2A312W and SM2A312DBZ features

MINI-BEAM[®] Sensors - SM2A312DBZ and SM2A312W

MINI-BEAM AC Specifications

Supply Voltage and Current	24 to 240V ac (50/60 Hz), 250V ac max
Supply Protection Circuitry	Protected against transient voltages
Output Configuration	SPST SCR solid-state relay with either normally closed or normally open contact (light/dark operate selectable); 2-wire hookup
Output Rating	Minimum load current 5 mA; maximum steady-state load capability 300 mA to 50°C ambient (122°F) 100 mA to 70°C ambient (158°F) Inrush capability 3 amps for 1 second (non-repetitive); 10 amps for 1 cycle (non-repetitive) Off-state leakage current less than 1.7 mA rms On-state voltage drop ≤5 volts at 300 mA load, ≤10 volts at 15 mA load
Output Protection Circuitry	Protected against false pulse on power-up
Output Response Time	8 milliseconds on and off “OFF” response time specification does not include load response of up to ½ ac cycle (8.3 milliseconds). Response time specification of load should be considered when important. (NOTE: 300 millisecond delay on power-up.)
Repeatability	2.6 milliseconds; response time and repeatability specifications are independent of signal strength.
Adjustments	Light/Dark Operate select switch, and 15-turn slotted brass screw Gain (Sensitivity) adjustment potentiometer (clutched at both ends of travel). Both controls are located on rear panel of sensor and protected by a gasketed, clear acrylic cover.
Indicators	Red indicator LED on rear of sensor is ON when the load is energized.
Construction	Reinforced PBT polyester housing, totally encapsulated, o-ring sealing, acrylic lenses, and stainless steel screws
Environmental Rating	Meets NEMA standards 1, 2, 3, 3S, 4, 4X, 12, and 13; IEC IP67
Connections	PVC-jacketed 2-conductor 2 m (6.5') or 9 m (30') cables, or 3-pin Micro-style quick-disconnect (QD) fitting are available. QD cables are ordered separately. See page 6.
Operating Conditions	Temperature: -20° to +70°C (-4° to +158°F) Maximum Relative Humidity: 90% at 50°C (non-condensing)
Application Notes	i) AC MINI-BEAMS may be destroyed from overload conditions ii) Use on low voltage requires careful analysis of the load to determine if the leakage current or on-state voltage of the sensor will interfere with proper operation of the load iii) The false-pulse protection feature may cause momentary drop-out of the load when the sensor is wired in series or in parallel with mechanical switch contacts
Certifications	

MINI-BEAM[®] Sensors - SM2A312DBZ and SM2A312W

MINI-BEAM AC Hookups

AC Sensors with Attached Cable

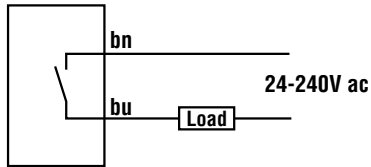

AC Sensors with Quick-Disconnect (3-Pin Micro-Style)

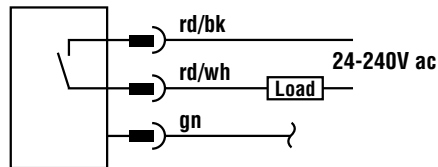

3-Pin Micro-Style Pin-out (Cable Connector Shown)

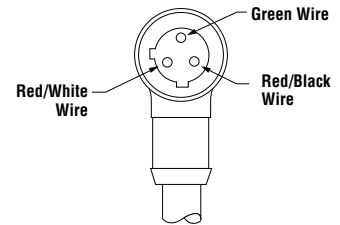

MINI-BEAM Dimensions

MINI-BEAM AC Sensor with Integral Cable

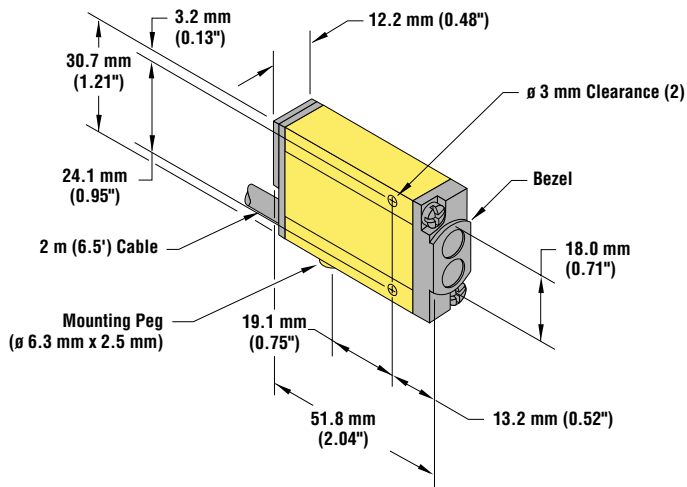

MINI-BEAM AC Sensor with Quick-Disconnect

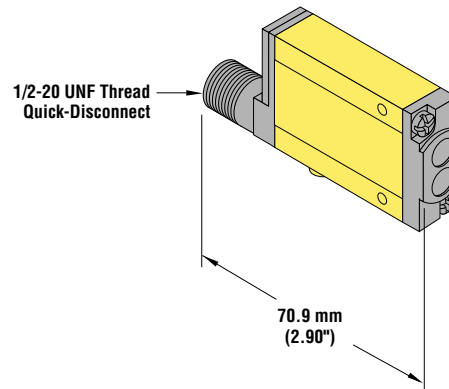

MINI-BEAM® Sensors - SM2A312DBZ and SM2A312W

MINI-BEAM Modifications			
Model Suffix	Modification	Description	Example of Model Number
W/30	9 m (30') cable	All MINI-BEAM sensors may be ordered with an integral 9 m (30') cable in place of the standard 2 m (6.5') cable	SM2A312W W/30
QDP	Pigtail Quick-Disconnect	All MINI-BEAMS may be built with a 150 mm (6") long integral cable which is terminated with the appropriate QD connector.	SM2A312WQDP



Replacement Lens Assemblies		
MINI-BEAM lens assemblies are field-replaceable.		
Model	Description	
UC-300BZ	Replacement lens for DBZ and W models	

Right-Angle Reflectors		
MINI-BEAM right-angle reflectors are useful for tight sensing locations. NOTE: These reflectors significantly decrease excess gain.		
Model	Description	
RAR-300SM	<ul style="list-style-type: none"> • Side-mount reflector • Profile dimension of 14 mm (0.56") in the direction of the scan 	

Extension Cables (without connectors)		
The following cables are available for extending the length of existing sensor cable. These 30 m (100') lengths of MINI-BEAM cable may be spliced to existing cable. Connectors, if used, must be customer-supplied.		
Model	Type	Used with:
EC312A-100	2-conductor	All MINI-BEAM SM2A312 ac models

MINI-BEAM® Sensors - SM2A312DBZ and SM2A312W

Micro-Style Quick-Disconnect Cables

Cable: PVC jacket, polyurethane connector body, nickel-plated brass coupling nut
Conductors: 22 or 20 AWG high-flex stranded, PVC insulation, gold-plated contacts
Temperature: -40° to +80°C (-40° to +176°F)
Voltage Rating: 250V ac/300V dc









Style	Model	Length	Dimensions	Pin-out
3-Pin Straight	MQDC-306 MQDC-315 MQDC-330	2 m (6.5') 5 m (15') 9 m (30')		
3-Pin Right-angle	MQDC-306RA MQDC-315RA MQDC-330RA	2 m (6.5') 5 m (15') 9 m (30')		

MINI-BEAM Mounting Brackets

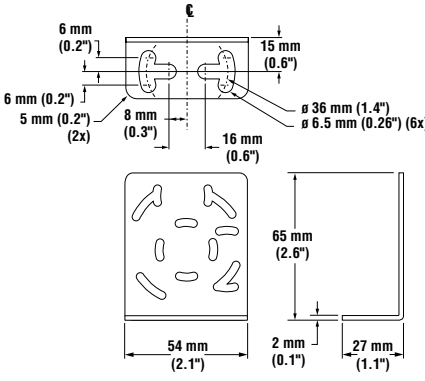
SMB312S	• 2-axis, side mounting bracket • Stainless steel	SMB312B	• Stainless steel 2-axis, bottom mounting bracket • Includes mounting foot

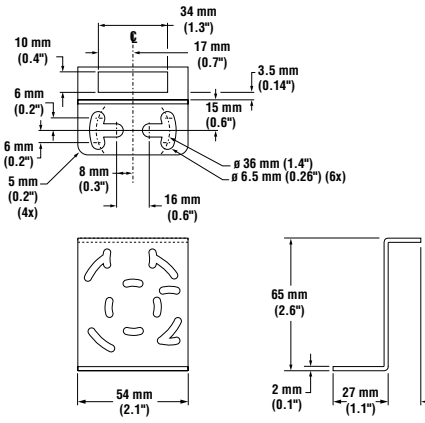
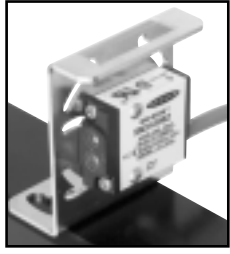
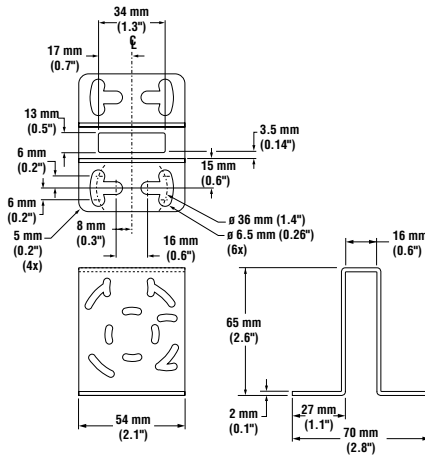
MINI-BEAM® Sensors - SM2A312DBZ and SM2A312W

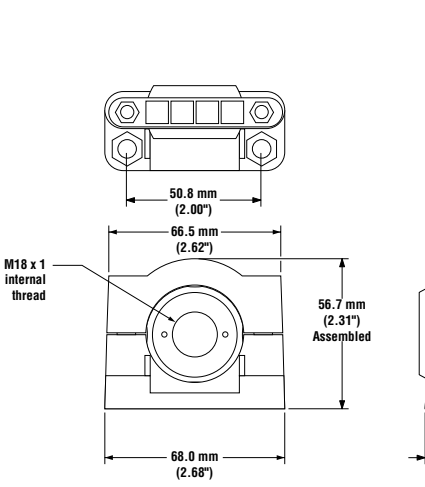
MINI-BEAM Mounting Brackets

<p>SMB46L</p>	<ul style="list-style-type: none"> • “L” bracket • 14 ga 316 stainless steel 	<p>SMB46S</p>	<ul style="list-style-type: none"> • “S” bracket • 14 ga 316 stainless steel
			
<p>SMB46U</p>	<ul style="list-style-type: none"> • “U” bracket • 14 ga 316 stainless steel 	<p>SMB3018SC</p>	<ul style="list-style-type: none"> • 18 mm swivel; barrel- or side-mount • Black thermoplastic polyester
			

MINI-BEAM[®] Sensors - SM2A312DBZ and SM2A312W

MINI-BEAM Mounting Brackets

SMB3018SUS	<ul style="list-style-type: none"> • Side-mount swivel – extended range of motion • Black thermoplastic polyester 	SMB30SK	<ul style="list-style-type: none"> • Flat-mount swivel bracket with extended range of motion • Black reinforced thermoplastic polyester and 316 stainless steel
-------------------	---	----------------	---

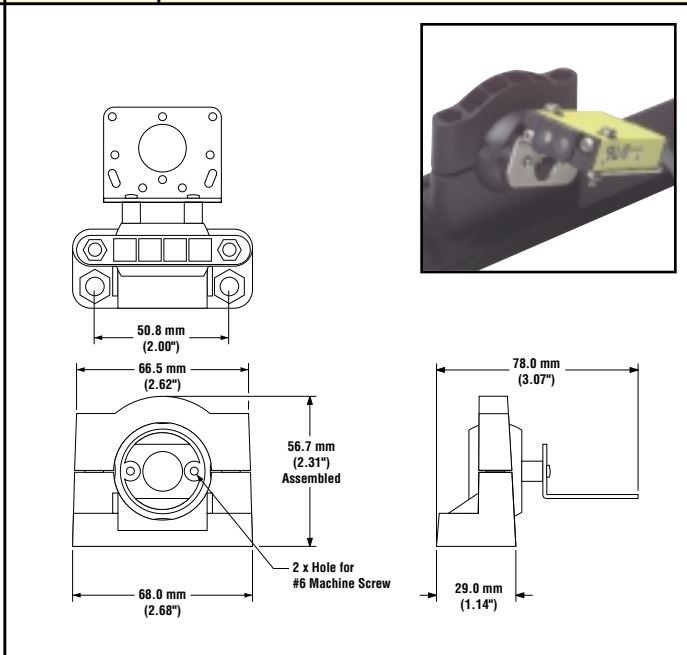
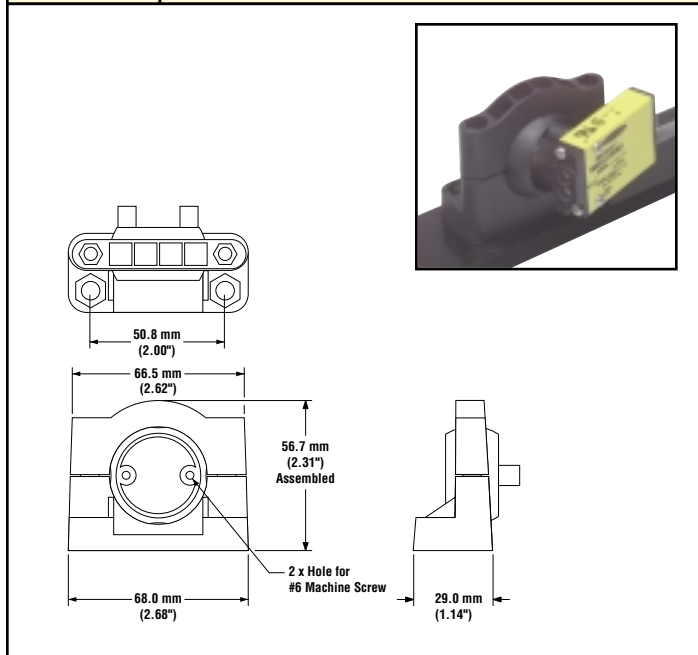

WARRANTY: Banner Engineering Corp. warrants its products to be free from defects for one year. Banner Engineering Corp. will repair or replace, free of charge, any product of its manufacture found to be defective at the time it is returned to the factory during the warranty period. This warranty does not cover damage or liability for the improper application of Banner products. This warranty is in lieu of any other warranty either expressed or implied.



WARNING . . . Not To Be Used for Personnel Protection

Never use these products as sensing devices for personnel protection. Doing so could lead to serious injury or death.

These sensors do NOT include the self-checking redundant circuitry necessary to allow their use in personnel safety applications. A sensor failure or malfunction can cause either an energized or de-energized sensor output condition. Consult your current Banner Safety Products catalog for safety products which meet OSHA, ANSI and IEC standards for personnel protection.