

D11 Expert Series



Low-cost TEACH-mode sensors for use with plastic fiber optics



Models available with integral 2 m (6.5 ft) cable or Pico-style quick-disconnect (QD) connector; 9 m (30 ft) cables are also available

- Low-cost, 10 to 30V dc, self-contained, TEACH-mode sensors for use with all Banner plastic fiber optics
- Compact 11 mm-wide housing designed for DIN rail mounting; also mounts to other surfaces using the supplied mounting bracket
- Easy push-button TEACH-mode programming automatically adjusts sensitivity to optimal setting
- D11E sensors are designed for low-contrast sensing applications (sensitivity set to just above the “dark” condition)
- D11E2 series sensors set the switching point midway between the “dark” and “light” conditions to ignore subtle changes, such as web flutter
- Fast, 200 microsecond (0.2 millisecond) output response; a 40 millisecond output pulse stretcher also may be programmed
- Models available with NPN (sinking) or PNP (sourcing) output
- Output may be programmed for either light operate (“LO”) or dark operate (“DO”)
- Separate input allows remote programming by an external device, such as a switch or a process controller
- LED status indications for power ON, output state, received signal strength, and sensing contrast

Models	Switching Threshold Setting	Cable	Output Type	Maximum Range (Diffuse mode performance based on 90% reflectance white test card)
D11EN6FP	Just above the “dark” condition	2 m (6.5 ft)	NPN (sinking)	Range varies by sensing mode and fiber optics used: • PIT46U fibers, opposed mode: 180 mm (7.1") ¹ • PIT26U fibers, opposed mode: 50 mm (2.0") • PBT46U fiber, diffuse mode: 50 mm (2.0") • PBT26U fiber, diffuse mode: 10 mm (0.4")
D11EN6FPQ		4-pin Pico QD		
D11EP6FP		2 m (6.5 ft)	PNP (sourcing)	
D11EP6FPQ		4-pin Pico QD		
D11E2N6FP	Midway between “dark” and “light” conditions	2 m (6.5 ft)	NPN (sinking)	
D11E2N6FPQ		4-pin Pico QD		
D11E2P6FP		2 m (6.5 ft)	PNP (sourcing)	
D11E2P6FPQ		4-pin Pico QD		

Standard 2 m (6.5 ft) cable models are listed. To order the 9 m (30 ft) cable model, add suffix "W/30" to the cabled model number. For example, D11EN6FP W/30. Models with a QD connector require a mating cable. (See Accessories).



WARNING: Not To Be Used for Personnel Protection
Never use this device as a sensing device for personnel protection. Doing so could lead to serious injury or death. This device does not include the self-checking redundant circuitry necessary to allow its use in personnel safety applications. A sensor failure or malfunction can cause either an energized or de-energized sensor output condition.

Specifications

Supply Voltage and Current

10 to 30V dc (10% maximum ripple) at less than 45 mA, exclusive of load

Required Fiber Optic Cable

PI or PB Series plastic fibers

¹ Opposed-mode range may be extended using optional lenses (see catalog for available lenses).

Supply Protection Circuitry

Protected against reverse polarity and transient voltages

Output Configuration

One (SPST) NPN (sinking) or PNP (sourcing) open-collector transistor, depending on model; programmable for light or dark operate

Output Rating

150 mA maximum

Off-state leakage current: <5 microamps at 30V dc

On-state saturation voltage: <1V at 10 mA dc; <1.5V at 150 mA dc

Output Protection Circuitry

Protected against false pulse on power-up and continuous overload or short-circuit

Output Response Time

200 microseconds (0.2 milliseconds) ON and OFF (40 milliseconds OFF when pulse stretcher is programmed). NOTE: 100 millisecond delay on power-up; output is non-conducting during this time

Output Timing Functions

ON/OFF (no delay) or fixed 40 millisecond OFF-delay pulse stretcher; selected by push button

Operating Temperature

-10 to +55 °C (-14 to +131 °F)

Maximum relative humidity 90% at 50°C (non-condensing)

Certifications**Sensing Beam**

Visible red, 680 nm

Repeatability

66 microseconds

Adjustments

Push button TEACH mode sensitivity setting (see TEACH mode, page 2); remote TEACH mode input is provided

Indicators

Three LEDs: Green, Yellow and Red

Green LED lights for dc power ON and flashes when ready to register sensing condition during TEACH mode; 1 Hz when waiting to learn first sensing condition; 2 Hz when waiting to learn second sensing condition; 4 Hz when output is overloaded.

Yellow LED lights for output ON (conducting).

Red LED is Banner's patented Alignment Indicating Device (AID™, U.S. patent #4356393) which lights whenever the sensor "sees" a light condition and superimposes a pulse rate which is proportional to the strength of the received light signal (the stronger the signal, the faster the pulse rate).

Construction

Black ABS flame retardant housing with acrylic cover
Stainless steel M3 x 0.5 hardware for use with ABS mounting bracket (supplied)

Environmental Rating

IEC IP54; NEMA 2

Connections

2 m (6.5 ft) or 9 m (30 ft) attached cable, or 4-pin Pico-style quick-disconnect fitting; Cables for QD models are purchased separately

Run Mode

Run mode is the normal operation of the D11 Expert series. The LED indicators operate in Run mode, as follows:

		Indicator	LED Color	Function
	1	Signal Strength (SIG)	Red	Lights when the sensor "sees" its modulated light source and pulses at a rate proportional to the received light signal strength.
	2	Output	Amber	Follows the action of the output: <ul style="list-style-type: none"> On when the output is energized Off when the output is de-energized
	3	Power ON	Green	Solid when power is applied. Flashes at approximately 4 Hz to indicate the output is overloaded
	4	Button	n/a	Programming push button

The Signal Strength indicator is Banner's exclusive AID™ (Alignment Indicating Device²). This feature simplifies accurate alignment during TEACH mode and provides a means of signaling when maintenance is needed during Run mode. When the pulse rate is slow, clean the fiber sensing ends and check the alignment.

Maximum Sensitivity/Factory Defaults

The sensors are factory-programmed for maximum sensitivity. This default setting may be easily recalled by holding the push button for two or more seconds to enter TEACH mode, and then clicking the push button four times in a row.

The default program also is set for light operate output and pulse stretcher OFF, push button enabled.

Perform the following procedures to program your own settings.

TEACH Mode

Sensitivity is automatically set (and optimized) by “teaching” the sensor the “light” and “dark” conditions. This is accomplished in TEACH mode. TEACH mode requires that each of the two sensing conditions be presented to the fiber optics; when the push button is clicked, the sensor samples the sensing condition and registers it into memory. After the second sensing condition is registered, the D11 Expert automatically sets the sensitivity to the optimum value for the application, and then returns to Run mode.

NOTE: There is a period of a few seconds at the end of TEACH mode, before Run mode begins.

Light or Dark Operate Selection

The two sensing conditions may be presented in either order: the light condition first, and then the dark condition, or vice versa. The condition presented first is the condition for which the output energizes. (In other words, the output will be light operated if the light condition is TEACH condition #1, or the output will be dark operated if the dark condition is TEACH condition #1.)

D11E sensors automatically set to a point just above the “dark” condition for the best performance in low contrast sensing applications; D11E2 sensors automatically set to a point midway between the “dark” and “light” conditions, to ignore subtle changes, such as web flutter.

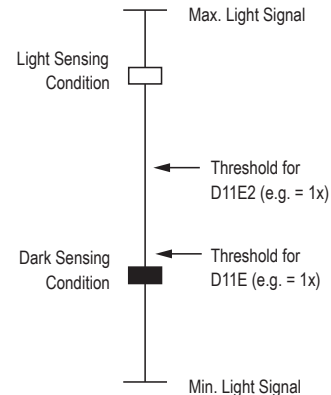

Contrast Indication

When the push button is clicked to teach the second sensing condition, the three LED indicators flash simultaneously to indicate relative sensing contrast. (Contrast is the difference in light level between the two sensing conditions.)

Higher contrast allows higher sensitivity level, and resulting higher excess gain. A high contrast level is directly related to sensing reliability, and is more forgiving of subtle changes in sensing conditions. The contrast display at the end of TEACH mode is shown.

NOTE: If the relative contrast level is unacceptable (1 flash), the program will return to TEACH condition #1.

No. of flashes at end of TEACH mode	Relative Contrast
1	Unacceptable
2	Low
3	Moderate
4	High

TEACH Mode Programming

Action	Indicator Status
Push and hold the button for more than 2 seconds.	Green LED: Flashes at 1 Hz Amber LED: Off

² U.S. Patent #4356393

Action	Indicator Status
	Red LED: Pulses to indicate relative received signal strength
TEACH Condition #1 Present the first sensing condition to the sensor and single-click the button. ³ This condition corresponds to the sensor output ON state.	Green: Flashes at 2 Hz Yellow: OFF Red: Pulses to indicate relative received signal strength.
TEACH Condition #2 Present the second sensing condition to the sensor and single-click the button. This condition corresponds to the sensor output OFF state.	Green, Yellow, and Red indicators flash simultaneously one to four times to indicate relative sensing contrast (see chart above). After a few seconds, the sensor returns to RUN mode.

Output Pulse Stretcher

A 40 millisecond pulse stretcher (OFF-delay) may be enabled for applications where a very short sensing event might be missed because of the response of the load or input connected to the sensor output. Turn the pulse stretcher ON or OFF using the following procedure.

Action	Indicator Status
Push and hold the button for more than 2 seconds.	Green LED: Flashes at 1 Hz Amber LED: Off Red LED: Pulses to indicate relative received signal strength
Pulse Stretcher Double-click the button to display status. Single-click the button to toggle pulse stretcher ON or OFF	Pulse Stretcher ON Green: Off Amber: Off Red: Solid on Pulse Stretcher OFF Green: Off Amber: Off Red: Double-flash
Double-click the button to save the configuration and return to Run mode.	See Run Mode on page 2

Hookup Diagrams

Sensors with NPN (Sinking) Outputs

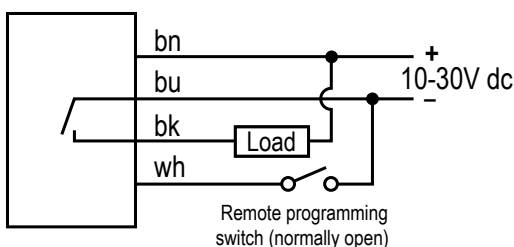

Figure 1. Cabled Hookup

Sensors with PNP (Sourcing) Outputs

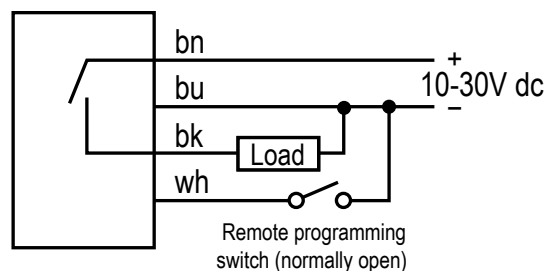

Figure 2. Cabled Hookup

³ The sensor returns to RUN mode if the first TEACH condition is not registered within 20 seconds. TEACH mode may be cancelled before either condition #1 or #2 by pressing the push button for more than 2 seconds.

Sensors with NPN (Sinking) Outputs

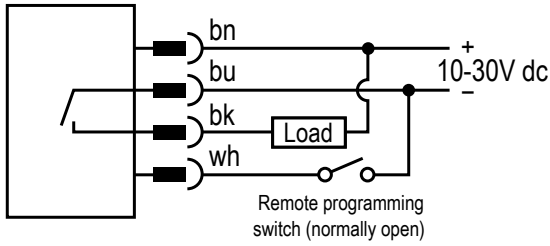

Figure 3. Quick Disconnect Hookup

Sensors with PNP (Sourcing) Outputs

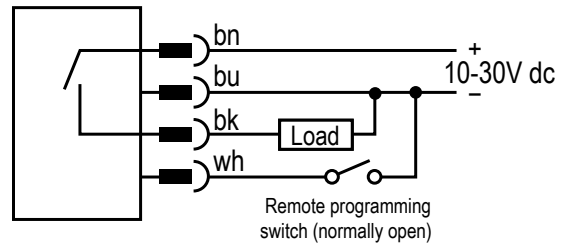

Figure 4. Quick Disconnect Hookup

Accessories

4-Pin Snap-on M8/Pico-Style Cordsets				
Model	Length	Style	Dimensions	Pinout
PKG4-2	2.00 m (6.56 ft)	Straight		<p>1 = Brown 2 = White 3 = Blue 4 = Black</p>
PKW4Z-2	2.00 m (6.56 ft)	Right-Angle		

Dimensions

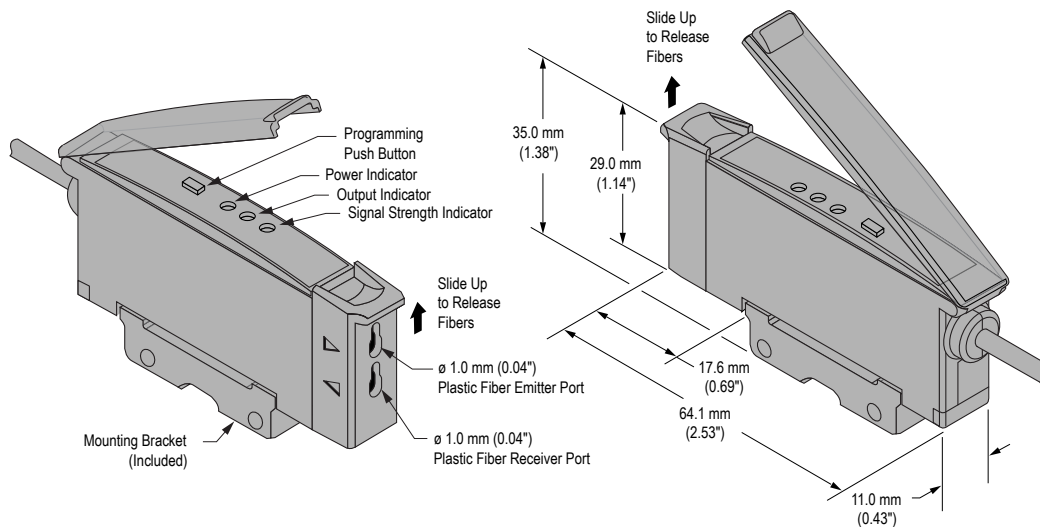

Figure 5. Cabled Models

Plastic Fiber Installation:

1. Cut fiber ends per instructions included with the fibers. Slide the fiber gripper up (open). For 0.25 mm or 0.5 mm diameter fibers, insert the adapter (shown below) into the ports as far as it will go.
2. All sizes plastic fibers: Insert the prepared plastic fiber sensor ends gently into the ports as far as they will go.

3. Slide the fiber gripper back down to lock.

A fiber adaptor is included for use with 0.25 mm (0.01") or 0.5 mm (0.02") diameter fibers.

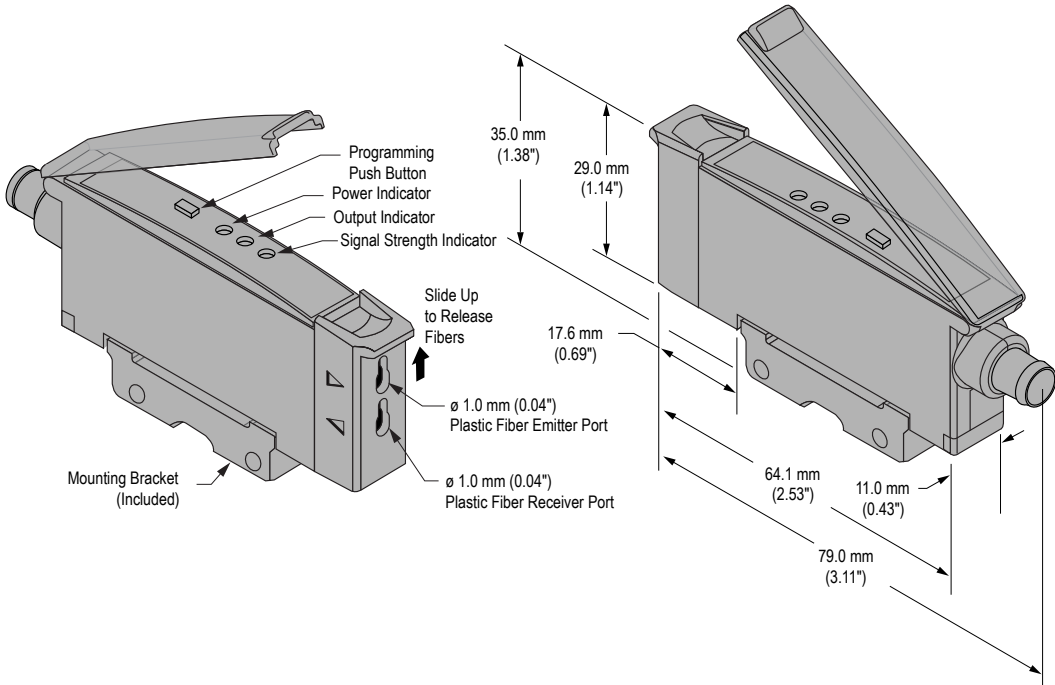
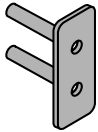

Figure 6. Quick Disconnect Models

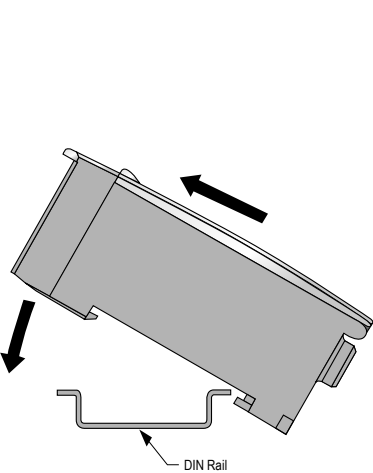

Figure 7. DIN Rail Mounting

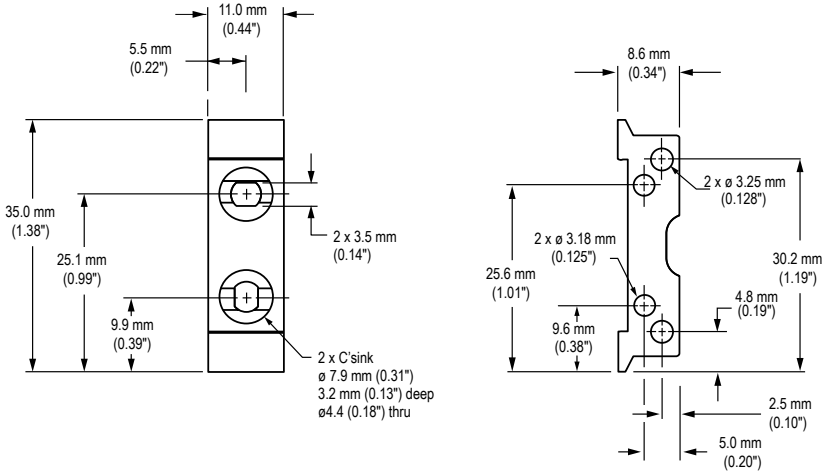

Figure 8. Mounting Bracket

Remote Programming

Connect the D11 Expert's white wire to a remote switch for three sensor programming functions:

- 1. Disable or enable the push button
2. TEACH mode programming of sensitivity

3. Enable or disable the 40- millisecond pulse stretcher.

Connect a remote programming switch between the white wire and dc common (see [Hookup Diagrams](#) on page 4). The switch may be either a normally open contact, or an open-collector NPN transistor with its emitter connected to dc common.

Program the sensor using a specified sequence of input pulses. The duration of each pulse is defined as: **0.04 seconds < T < 0.8 seconds**.

The required spacing between adjacent pulses in a sequence (e.g., a "double-pulse") is: **0.04 < T < 0.8 seconds**. The timing diagrams illustrate the input requirements.

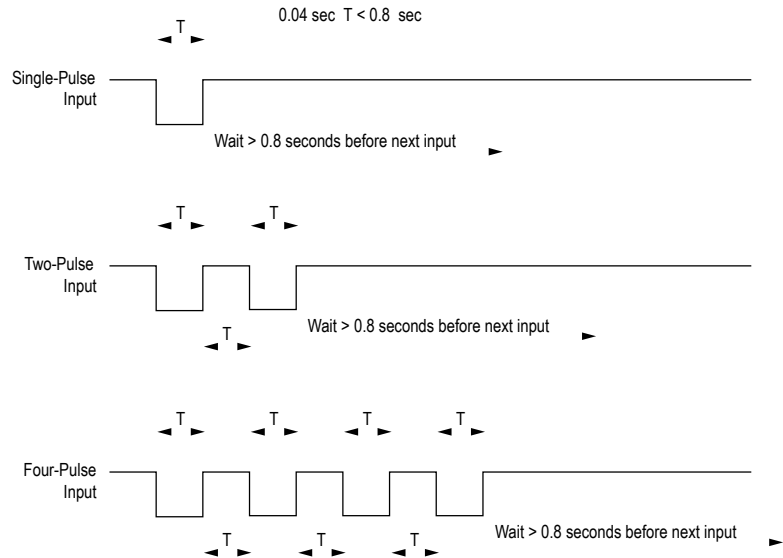

Figure 9. Timing Programs

Disable or Enable the Push Button

When remote programming is used exclusively, it may be beneficial to disable the push button on the D11E to increase the security of the settings.

1. To disable the push button: Pulse the remote input four times.
2. To enable the push button at a later date: Pulse the input four times (again).



NOTE: The push button can be enabled and/or disabled via remote line only.

Set Sensitivity Via TEACH Mode

1. Present the first (output ON) sensing condition to the sensor and pulse the remote input once.
2. Present the second (output OFF) sensing condition to the sensor and pulse the remote input once. The three LED indicators flash simultaneously one to four times to indicate relative sensing contrast. The sensor returns to RUN mode.

Enable or Disable the 40-millisecond Pulse Stretcher

1. Pulse the remote input two times. The status of the pulse stretcher is indicated by the red LED: ON if the pulse stretcher is ON, and double-flash if the pulse stretcher is OFF.
2. Pulse the remote input once to toggle the pulse stretcher ON or OFF.
3. Pulse the remote input two times to save the setting and return to Run mode.

Banner Engineering Corp Limited Warranty

Banner Engineering Corp. warrants its products to be free from defects in material and workmanship for one year following the date of shipment. Banner Engineering Corp. will repair or replace, free of charge, any product of its manufacture which, at the time it is returned to the factory, is found to have been defective during the warranty period. This warranty does not cover damage or liability for misuse, abuse, or the improper application or installation of the Banner product.

THIS LIMITED WARRANTY IS EXCLUSIVE AND IN LIEU OF ALL OTHER WARRANTIES WHETHER EXPRESS OR IMPLIED (INCLUDING, WITHOUT LIMITATION, ANY WARRANTY OF MERCHANTABILITY OR FITNESS FOR A PARTICULAR PURPOSE), AND WHETHER ARISING UNDER COURSE OF PERFORMANCE, COURSE OF DEALING OR TRADE USAGE.

This Warranty is exclusive and limited to repair or, at the discretion of Banner Engineering Corp., replacement. **IN NO EVENT SHALL BANNER ENGINEERING CORP. BE LIABLE TO BUYER OR ANY OTHER PERSON OR ENTITY FOR ANY EXTRA COSTS, EXPENSES, LOSSES, LOSS OF PROFITS, OR ANY INCIDENTAL, CONSEQUENTIAL OR SPECIAL DAMAGES RESULTING FROM ANY**

PRODUCT DEFECT OR FROM THE USE OR INABILITY TO USE THE PRODUCT, WHETHER ARISING IN CONTRACT OR WARRANTY, STATUTE, TORT, STRICT LIABILITY, NEGLIGENCE, OR OTHERWISE.

Banner Engineering Corp. reserves the right to change, modify or improve the design of the product without assuming any obligations or liabilities relating to any product previously manufactured by Banner Engineering Corp.