



- Interface Modules provide isolated safety output contacts for a primary safety device (e.g., a safety light screen or safety module) which has solid-state or hard contact outputs and external device monitoring (EDM) capability.
- Model **IM-T-9A** features three normally open 6 amp redundant-output channels.
- Model **IM-T-11A** features two normally open redundant-output channels and one normally closed non-safety auxiliary output channel, all rated at 6 amps.
- Normally closed outputs for connection to the primary safety device's monitoring input.
- 24V dc operation
- 22.5 mm (0.9") DIN-rail-mountable housing
- Convenient plug-in terminal blocks

Overview

Interface Modules **IM-T-9A** and **IM-T-11A** (the Interface Modules) operate on 24V dc inputs and provide isolated redundant output channels for interfacing dc safety controls (such as safety light screens or other safety modules) to safety circuits. These modules can also be used to switch low power capacity of safety controls with low current output rating (see hookup figures and the output configuration specifications).

The outputs of the Interface Module will follow the action of the safety outputs from the primary safety device which control it, within a 20 millisecond switching delay time. The Interface Module's normally open outputs each are rated for up to 250V ac/dc at up to 6 amps.

The Interface Module offers a series connection of normally closed contacts (labeled Y1-Y2 and Y3-Y4) for monitoring by the external device monitoring (EDM) function of the primary safety device. These forced-guided (mechanically-linked) contacts allow the safety device to detect failures of the Interface Module, and at a minimum, must be monitored in applications requiring Control Reliability per OSHA/ANSI or Category 3 or 4 per ISO13849-1.

WARNING . . . Not a Point-of-Operation Guarding Device

This Interface Module is not a point-of-operation guarding device, as defined by OSHA regulations. It is necessary to install point-of-operation guarding devices, such as safety light curtains and/or hard guards, to protect personnel from hazardous machinery. **Failure to install point-of-operation guards on hazardous machinery can result in a dangerous condition which could lead to serious injury or death.**

Models IM-T-9A and IM-T-11A – Interface Modules

⚠ Important ... read this before proceeding!

The user is responsible for satisfying all local, state, and national laws, rules, codes, and regulations relating to the use of this product and its application. Banner Engineering Corp. has made very effort to provide complete application, installation, operation, and maintenance instructions. Please direct any questions regarding the use or installation of this product to the factory applications department at the telephone numbers or address shown on the back cover.

The user is responsible for making sure that all machine operators, maintenance personnel, electricians, and supervisors are thoroughly familiar with and understand all instructions regarding the installation, maintenance, and use of this product, and with the machinery it controls. The user and any personnel involved with the installation and use of this product must be thoroughly familiar with all applicable standards, some of which are listed below. Banner Engineering Corp. makes no claim regarding a specific recommendation of any organization, the accuracy or effectiveness of any information provided, or the suitability of the provided information for a specific application.

Applicable U.S. Standards

ANSI B11 Standards for Machine Tools

Contact: Safety Director, AMT – The Associations for Manufacturing Technology,
7901 Westpark Drive, McLean, VA 22102, Tel: 703-893-2900

ANSI NFPA79 Electrical Standard for Industrial Machinery

Contact: National Fire Protection Association, 1 Batterymarch Park, P.O. Box 9101,
Quincy, MA 02269-9101, Tel: 800-344-3555

ANSI/RIA R15.06 Safety Requirements for Industrial Robots and Robot Systems

Contact: Robotic Industries Association, 900 Victors Way, P.O. Box 3724, Ann Arbor,
MI 48106, Tel: 734-994-6088

Applicable International Standards

ISO 12100-1 (EN292-1) Safety of Machinery – Basic Concepts, General Principles for Design, Part 1: Basic Terminology, Methodology

ISO 12100-2 (EN 292-2) Safety of Machinery – Basic Concepts, General Principles for Design, Part 2: Technical Principles and Specifications

IEC 60204-1 Electrical Equipment of Machines: Part 1: General Requirements.
(Also request a type “C” standard for specific machinery.)

ISO 13849-1 (EN954-1) Safety of Machinery – Related Parts of Control Systems: Part 1 General Principles for Design

Contact: Global Engineering Documents, 15 Inverness Way East, Englewood, CO
80112-5704, Tel: 800-854-7179

Certificate of Adequacy

This Safety Module data sheet (p/n 62822) satisfies the requirements of Machinery Directive 2006/42/EC, Section 1.7.4 — instructions.

Two green indicator LEDs on the front of each Interface Module indicate the output status of internal relays K1 and K2.

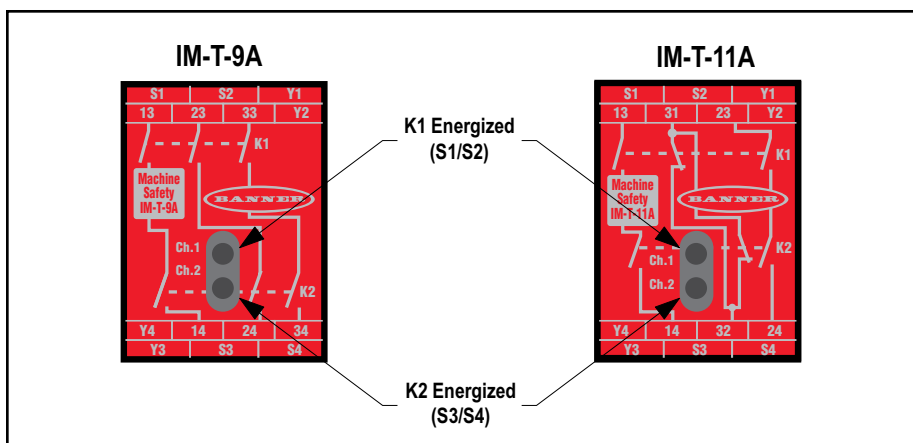

Figure 1. Interface Module status indicators

Primary Safety Device Requirements

⚠ WARNING . . . Not for Use As a Stand-Alone Safety Module

1. **DO NOT** connect E-stop switches, 2-hand control actuators/switches, safety interlock switches, or similar devices directly to this Interface Module.
2. **ALWAYS** connect terminals Y1-Y2 and Y3-Y4 of this Interface Module to the monitoring input of the primary safety device that controls it (see Figures 4 through 8).

This Module does not have the circuitry required to perform a self-check. A single fault inside the unit or in external devices (like switches or E-stop buttons) can go undetected and create an unsafe condition. **Failure to properly connect this Interface Module to a primary safety device with a monitoring function could result in serious injury or death.**

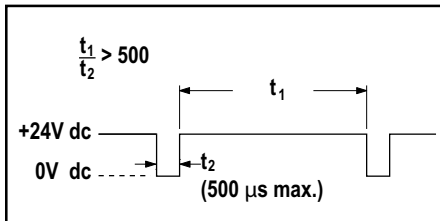

Figure 3. Requirements for pulsed output signals from a primary safety device

Interface Modules **IM-T-9A** and **IM-T-11A** are driven by one or two safety output channels of a primary safety device. For higher risk applications, the design of the primary safety device must meet OSHA/ANSI control reliability requirements (U.S. applications) or ISO/IEC/EN Category 3 or 4, Performance Level d or e, and SIL 2 or 3 requirements for European applications. **IM-T-..A** Modules must be used only with primary safety devices which have External Device Monitoring capability (see Figures 4 through 8 and the Warning Interfacing MPCEs on page 7).

At a minimum, each output channel of the primary safety device must:

- Include one normally open forced-guided (mechanically linked) contact (FSD), or
- Include one solid-state 24V dc sourcing safety output (OSSD), and
- Be self-monitored to result in a safe (OFF) condition in the event of a failure, and
- Be capable of switching 50 mA @ 24V dc \pm 15%.

NOTE: As OSSD solid-state outputs on primary safety devices very often are pulsed, it is possible that the relay coils will produce an audible buzzing. This relay buzzing does not affect the function of the Interface Module, as long as the pulse width is below 500 μ s (microseconds) and the duty cycle (t_1/t_2) is greater than 500.

Final Switching Device (FSD): The component of the machine's safety-related control system that interrupts the circuit to the machine primary control element (MPCE) when the output signal switching device (OSSD) goes to the OFF-state.

Output Signal Switching Device (OSSD): The component of the electro-sensitive protective equipment (ESPE) connected to the control system of the machine which, when the sensing device is actuated during normal operation, responds by going to the OFF-state.

Mechanical Installation

The Safety Module must be installed inside an enclosure. It is not designed for exposed wiring. It is the user's responsibility to house the Safety Module in an enclosure with NEMA 3 (IEC IP54) rating, or better.

The Safety Module mounts directly to standard 35 mm DIN rail; see Dimensions.

Heat Dissipation Considerations

For reliable operation, ensure that the operating specifications are not exceeded. The enclosure must provide adequate heat dissipation, so that the air closely surrounding the Module does not exceed the maximum operating temperature stated in the Specifications. Methods to reduce heat build-up include venting, forced airflow (e.g., exhaust fans), adequate enclosure exterior surface area, and spacing between modules and other sources of heat.

Models IM-T-9A and IM-T-11A – Interface Modules

Electrical Installation

It is not possible to give exact wiring instructions for an Interface Module which can be used with many different primary safety devices and can interface to a multitude of machine control configurations. The following guidelines are general in nature.

The Interface Module has no delay function. Its output relay contacts open within 20 milliseconds after a safety input opens. This classifies the Safety Module as functional stop "Category 0", as defined by ANSI NFPA 79 and IEC/EN 60204-1.

The inputs can be connected to (that meet the requirements for primary safety device above):

- A +24V dc solid-state (PNP) outputs in single-channel or dual-channel hookup configuration, or
- A +24V/0V dc source that is switched by hard/relay contacts in single-channel or dual-channel hookup configuration.

The **dual-channel hookup configuration (Figures 4 through 8)** allows the primary safety device to detect certain failures and faults, such as short circuits, that could result in a loss of the safety function. Two-channel control should be used whenever unsafe failure of the control wires cannot be eliminated. This circuit (Figure 4) can meet ISO 13849-1 Category 2, 3, or 4 requirements, depending on the safety rating and the installation of the primary safety device.

The outputs of the primary safety device must, at minimum, comply with the requirements described on page 3. These outputs must be monitored for failure by the primary safety device. In addition, a single output failure cannot prevent normal stopping action, and a successive cycle cannot be initiated until the failure has been corrected.

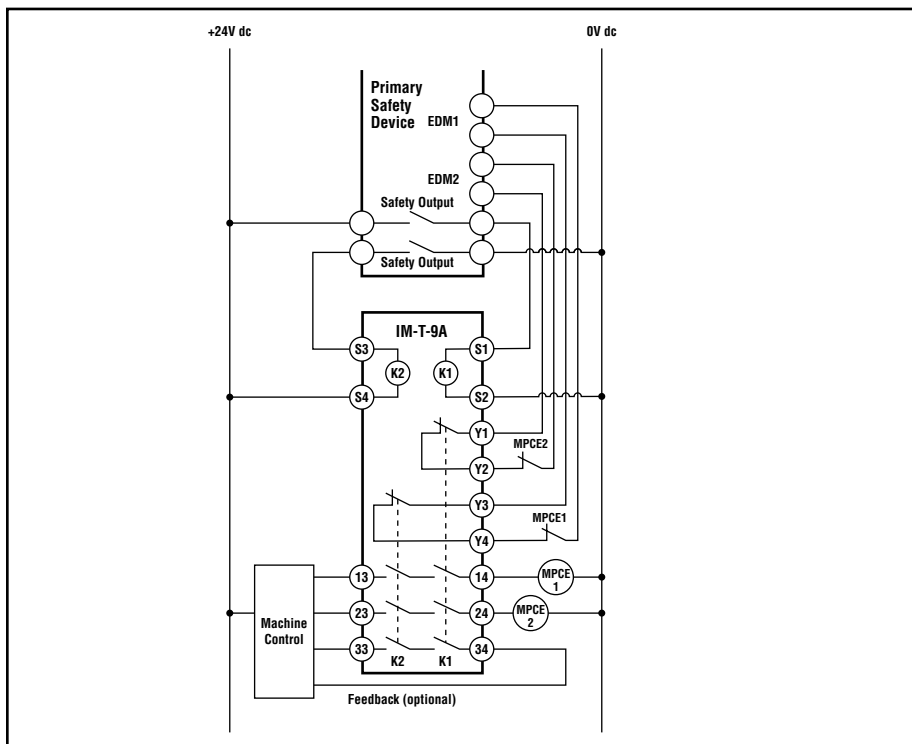

Figure 4. Generalized hookup to a 2-channel primary safety device with two hard-contact safety outputs (FSD1 and FSD2) and two monitoring inputs

⚠ CAUTION . . . Shock Hazard

Always disconnect all power from the Interface Module, the primary safety device, and all power from the machine being controlled before making any connections or replacing any component. Electrical installation and wiring must be made by qualified personnel and must comply with the NEC (National Electrical Code), ANSI NFPA79 or IEC 60204-1, and all applicable local standards and codes.

⚠ WARNING . . . Safety Categories

The level of safety circuit integrity can be greatly impacted by the design and installation of the safety devices and the means of interfacing of those devices. A risk assessment must be performed to determine the appropriate safety circuit integrity level or safety category as described by ISO 13849-1 (EN 954-1) to ensure that the expected risk reduction is achieved and that all relevant regulations and standards are complied with.

⚠ CAUTION . . .

When FSD1 switches +24V dc and FSD2 switches 0V dc (Figures 4 and 5), a short circuit between the wires leading to S1, S2, S3 and S4 is detected immediately and K1 and K2 de-energize. However, a short circuit can result in a high current through the FSD1 and FSD2 contacts, so the current coming from the 24V dc supply connected to FSD1 and FSD2 must be fused or limited to 6 amps max. Otherwise, damage to the primary safety device may result.

Models IM-T-9A and IM-T-11A – Interface Modules

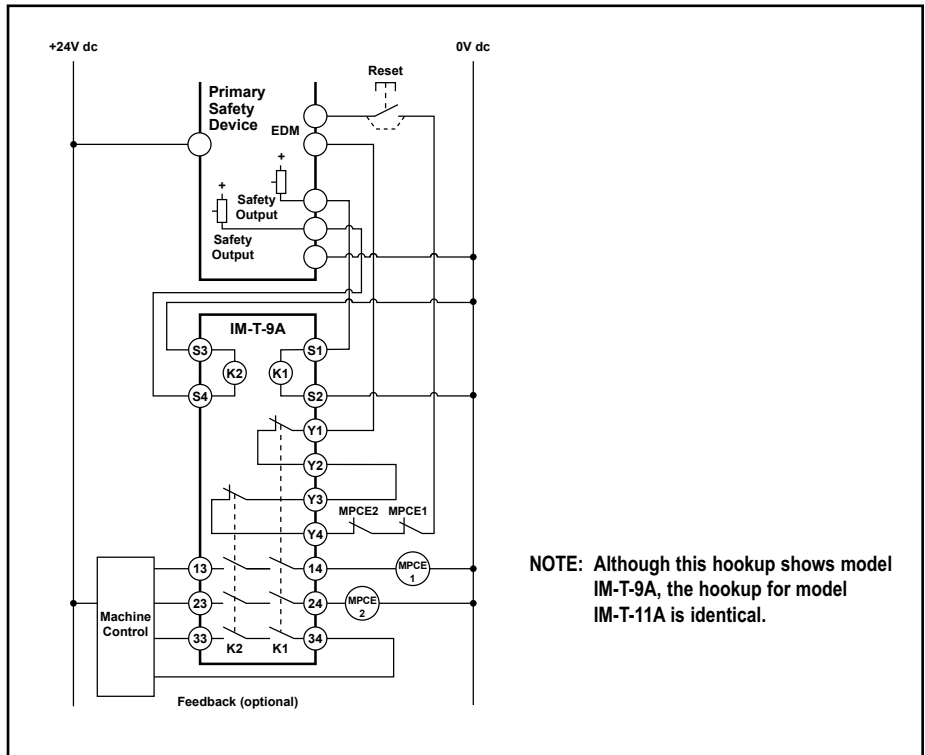

Figure 5. Generalized hookup to a 2-channel primary safety device with two hard-contact safety outputs and one monitoring contact feedback input

⚠ WARNING . . .
Use of Arc Suppressors

If arc suppressors are used, they **MUST** be installed across the actuator coil of the machine primary control elements (MPCE1, MPCE2). **NEVER** install suppressors directly across the output contacts of the Interface Module. It is possible for suppressors to fail as a short circuit. If installed directly across the output contacts of the Interface Module, a short-circuited suppressor will create an unsafe condition which could result in serious injury or death.

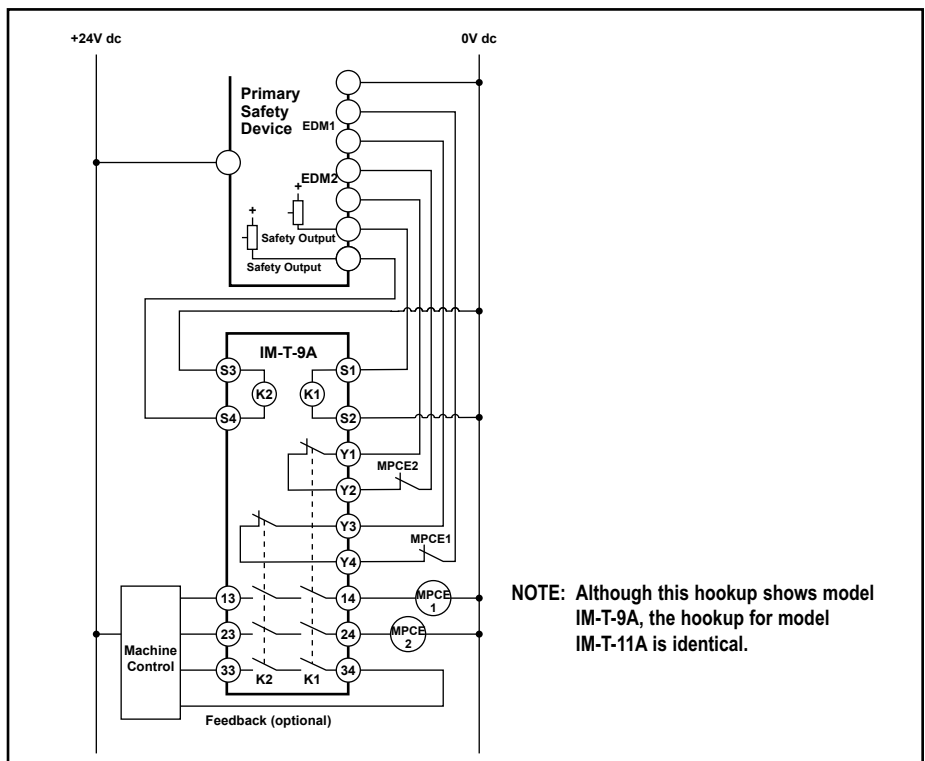

Figure 6. Generalized hookup to a 2-channel primary safety device with two current-sourcing safety outputs and two monitoring inputs

Models IM-T-9A and IM-T-11A – Interface Modules

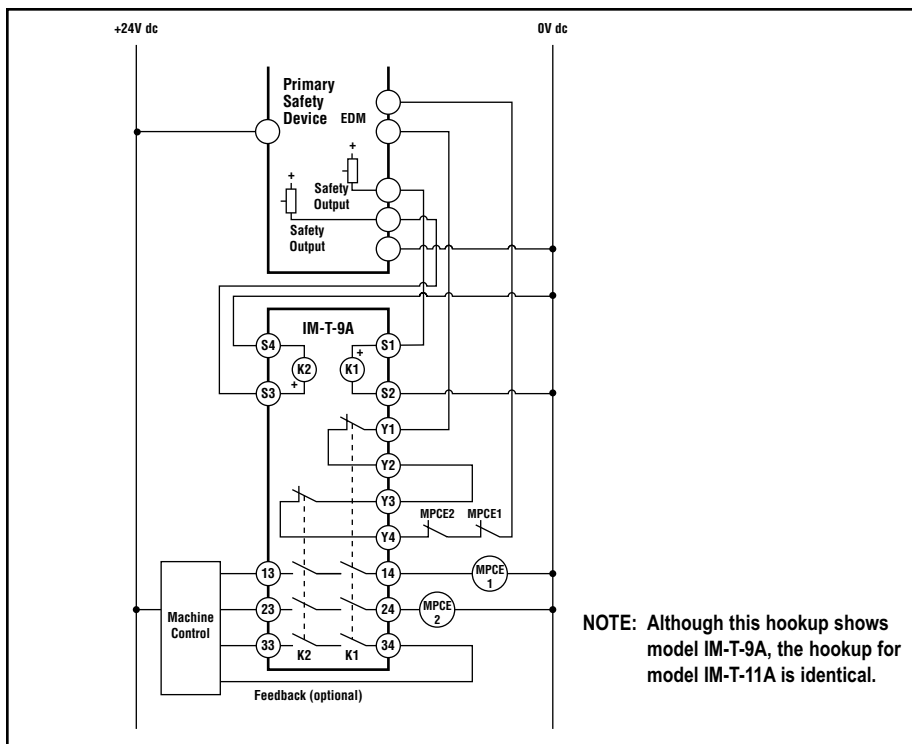

Figure 7. Generalized hookup to a 2-channel primary safety device with two current-sourcing safety outputs and one monitoring input

⚠ WARNING . . . Wiring of Arc Suppressors

If arc suppressors are used, they **MUST** be installed as shown across the coils of the machine primary control elements (MPCE1 to MPCE3). **NEVER** install suppressors directly across the output contacts of the Interface Module. It is possible for suppressors to fail as a short circuit. If installed directly across the output contacts of the Interface Module, a **short-circuited suppressor will create an unsafe condition which could result in serious injury or death.**

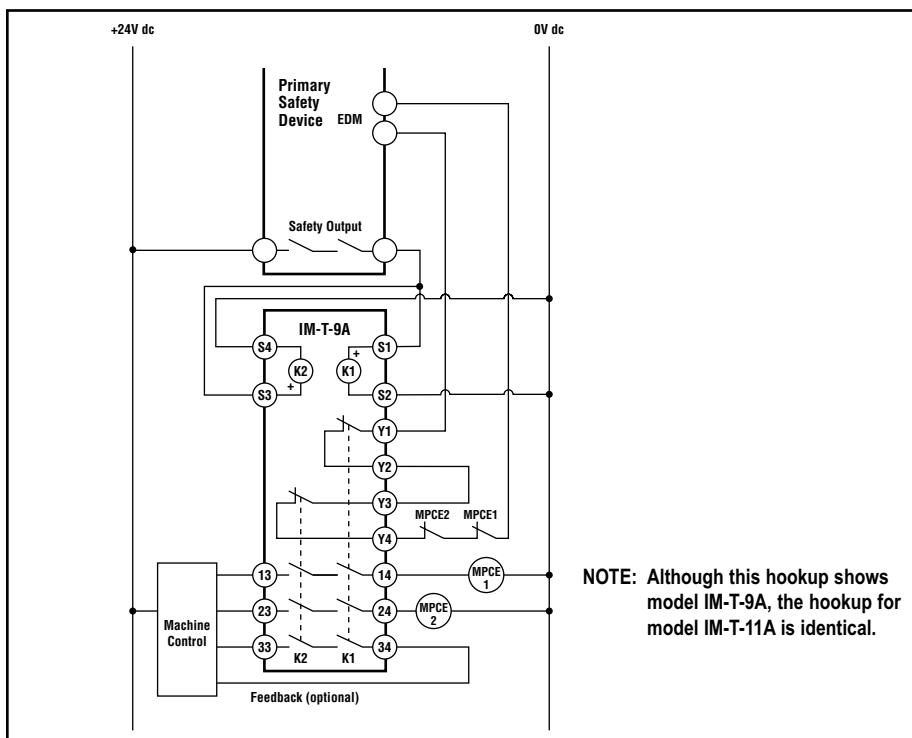

Figure 8. Generalized hookup to a primary safety device with one redundant relay safety output (one-channel control) and one monitoring input

⚠ WARNING . . . Single-Channel Hookup

Single-channel hookup, as shown in Figure 8, is only for use when the PSD and the Interface Module are within the same enclosure. Refer to page 9, One-Channel Control.

Models IM-T-9A and IM-T-11A – Interface Modules

The single-channel input hookup configuration (Figure 8) can not detect short circuits to secondary sources of +24V dc or detect the loss of the switching function of the primary safety device (i.e., it is not redundant) and thus this circuit typically can meet only ISO 13849-1 Category 2.

It is recommended that in all circumstances the installation of the Interface Module and its associated primary safety device are installed to eliminate or minimize the possibility of failures and faults that could result in the loss of the safety function(s).

Methods to eliminate or minimize the possibility of these failures include, but are not limited to:

- Physically separating interconnecting control wires from each other and from secondary sources of power.
- Routing interconnecting control wires in separate conduit, runs, or channels.
- Locating all elements (modules, switches, and devices under control) within one control panel, adjacent to each other, and directly connected with short wires.
- Properly installing multi-conductor cabling and multiple wires through strain-relief fittings. (Over-tightening of a strain-relief can cause short circuits at that point.)
- Using positive-opening components as described by IEC 60947-5-1 installed and mounted in a positive mode.
- Periodically checking the functional integrity / safety function and training operators, maintenance personnel, and others associated with the operation of the machine to recognize and immediately correct such failures.

If you have any questions about your intended use, please contact a Banner applications engineer at the numbers listed on the last page.

Connection to the Machine To Be Controlled

The hookup diagrams in Figures 5 through 9 show a generic connection of two safety output channels of the Interface Module to Machine Primary Control Elements MPCE1 and MPCE2. A Machine Primary Control Element is an electrically powered device, external to the Interface Module, which stops the machinery being controlled by immediately removing electrical power from the machine and (when necessary) by applying braking to dangerous motion.

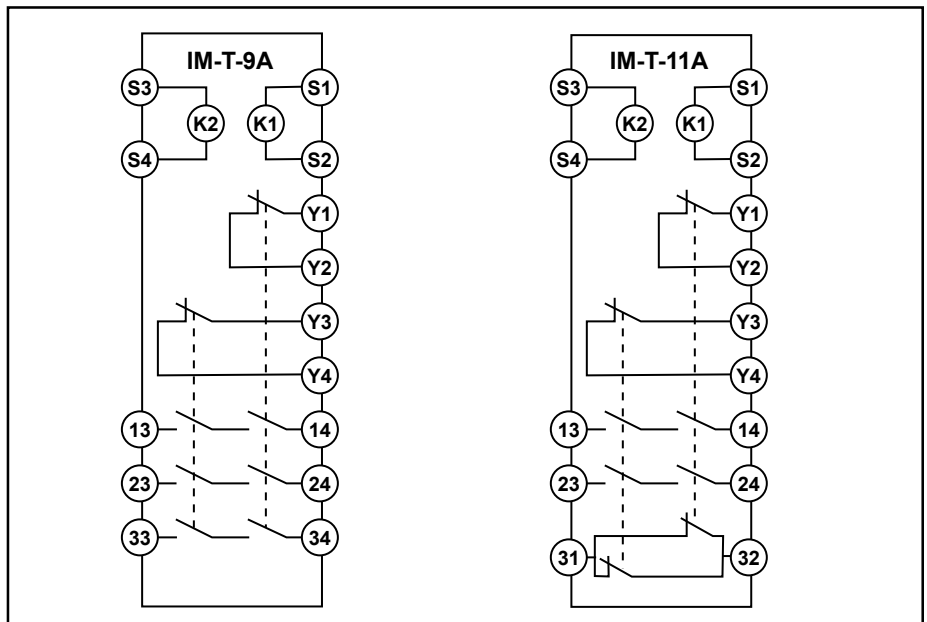

Figure 9. Interface Module pinouts

Models IM-T-9A and IM-T-11A – Interface Modules

External Device Monitoring

To satisfy the requirements of Control Reliability (OSHA and ANSI), Category 3 and 4 of ISO 13849-1 (EN 954-1), the Machine Primary Control Elements (MPCEs) must each offer a normally closed, forced-guided (mechanically linked) monitor contact. Connect one normally closed monitor contact from each Machine Primary Control Element as shown in the appropriate hookup drawing (figures 4 through 8).

In operation, if one of the switching contacts of either MPCE fails in the energized condition, the associated monitor contact will remain open. Therefore, it will not be possible to reset the primary safety device. If no MPCE-monitor contacts are monitored, **it is the user's responsibility to ensure that any single failure will not result in a hazardous condition and will prevent a successive machine cycle.**

Overvoltage Category II and III Installations (EN 50178 and IEC 60664-1)

The Interface Module is rated for Overvoltage Category III when voltages of 1V to 150V ac/dc are applied to the output relay contacts. It is rated for Overvoltage Category II when voltages of 151V to 250V ac/dc are applied to the output relay contacts and no additional precautions are taken to attenuate possible overvoltage situations in the supply voltage. The Module can be used in an Overvoltage Category III environment (with voltages of 151V to 250V ac/dc) if care is taken either to reduce the level of electrical disturbances seen by the Module to Overvoltage Category II levels by installing surge suppressor devices (e.g., arc suppressors), or to install extra external insulation in order to isolate both the Interface Module and the user from the higher voltage levels of a Category III environment.

For Overvoltage Category III installations with output contact voltage 151V to 250V ac/dc applied to the output contact(s): the Interface Module may be used under the conditions of a higher overvoltage category where appropriate overvoltage reduction is provided. Appropriate methods include:

- An overvoltage protective device
- A transformer with isolated windings
- A distribution system with multiple branch circuits (capable of diverting energy of surges)
- A capacitance capable of absorbing energy of surges
- A resistance or similar damping device capable of dissipating the energy of surges

Auxiliary Monitor Contact (Model IM-T-11A Only)

The action of the auxiliary monitor contact, terminals 31-32, inversely "follows" the action of the safety outputs. The 31-32 auxiliary monitor contact is to be used only for control functions that are NOT safety-related. A typical use is to communicate the status of the Safety Module output to a programmable logic controller (PLC).

Many types of mechanisms are used to arrest dangerous machine motion. Examples include mechanical braking systems, clutch mechanisms, and combinations of brakes and clutches. Additionally, control of the arresting scheme may be hydraulic or pneumatic. As a result, an MPCE may be one of several control types, including a wide variety of contactors and electromechanical valves. If your machine documentation leaves any doubt about the proper connection points for the Interface Module output contacts, do not make any connections. Contact the machine builder for clarification regarding connection to the MPCEs.

Two-Channel Control (Figures 4, 5, 6 and 7): Two-channel control allows the Primary Safety Device to detect an unsafe failure of the control wires. Two-channel control should be used whenever unsafe failure of the control wires cannot be eliminated.

The outputs of the primary safety device must at minimum, comply with the requirements described on page 5. These outputs must be monitored for failure by the primary safety device. In addition, a single output failure cannot prevent normal stopping action, and a successive cycle cannot be initiated until the failure has been corrected.

NOTICE regarding MPCEs

To achieve control reliability, two Machine Primary Control Elements (MPCEs) are required to control each machine hazard. Each MPCE must be capable of immediately stopping the dangerous machine motion, irrespective of the state of the other. Some machines offer only one primary control element. For such machines, it is necessary to duplicate the circuit of the single MPCE to add a second MPCE.

MPCEs must offer at least one forced-guided auxiliary contact which is wired to the monitoring contact feedback input of the primary safety device (see hookup diagrams).

WARNING . . . Interfacing MPCEs

NEVER wire any intermediate device(s) (e.g., PLC, PES, PC), between the Interface Module outputs and the Machine Primary Control Elements (MPCE1 to MPCE3) it switches, in such a manner that in the event of a failure there is the loss of the safety stop command, OR in such a manner that the safety function can be suspended, overridden, or defeated, unless accomplished with the same or greater degree of safety. Whenever forced-guided, mechanically linked relays are added as intermediate switching devices, a normally closed forced-guided monitor contact from each relay must be added to the series feedback loop between Interface Module terminals Y1, Y2, Y3, and Y4.

 **CAUTION . . . Disconnect Power Prior to Checkout**

Dangerous voltages may be present along the Safety Module wiring barriers whenever power to the machine control elements is ON.

Exercise extreme caution whenever machine control power is or may be present. Always disconnect power to the machine control elements before opening the enclosure housing of the Safety Module.

 **WARNING . . . Abuse of Module After Failure**

If an internal fault has occurred and the Module will not reset, **do not tap, strike, or otherwise attempt to correct the fault by a physical impact to the housing.** An internal relay may have failed in such a manner that its replacement is required.

If the Module is not immediately replaced or repaired, multiple simultaneous failures may accumulate such that the safety function can not be guaranteed.

Initial and Periodic Checkout Procedure

The Interface Module can be used safely only when its operation is controlled via an appropriate primary safety device, connected to the Interface according to the wiring diagrams shown in Figures 4 through 8.

The functioning of the Safety Module and the device(s) connected to it must be verified at initial installation and on a regular periodic basis to ensure proper operation (see also the machine manufacturer's recommendations).

Checkout procedure:

1. Remove the power controlling (and switched by) the machine control elements (see Caution).
2. Verify that the primary safety device which will be controlling the Interface Module is operating correctly, according to its product documentation and manufacturer's recommendations.
3. Confirm proper connection of the Interface Module to the controlling primary safety device according to the wiring diagram.
4. Verify that all Interface Module output contacts follow exactly the operation of the safety output contacts of the controlling primary safety device, when the primary safety device is operated according to its product documentation and manufacturer's recommendations.

Repairs



Do not attempt any repairs to the Safety Module. It contains no field-replaceable components. Return it to the factory for warranty repair or replacement.

Contact the Banner Factory Application Engineering Group at the address or at the numbers listed on the back page. They will attempt to troubleshoot the system from your description of the problem. If they conclude that a component is defective, they will issue a Return Merchandise Authorization (RMA) number for your paperwork, and give you the proper shipping address.

Pack the Safety Module carefully. Damage which occurs in return shipping is not covered by warranty.

Models IM-T-9A and IM-T-11A – Interface Modules

Specifications

Input Voltage and Current	24V dc, +/-15% no polarity, 10% maximum ripple; 50 mA per input channel (approximately 2.4 W)																						
Supply Protection Circuitry	Protected against transient voltages.																						
Overvoltage Category	Output relay contact voltage of 1V to 150V ac/dc: Category III Output relay contact voltage of 151V to 250V ac/dc: Category II (Category III, if appropriate overvoltage reduction is provided, as described on page 9.)																						
Pollution Degree	2																						
Output Configuration	<p>IM-T-9A: 3 normally open output channels IM-T-11A: 2 normally open output channels and 1 normally closed auxiliary output channel.</p> <p>Each normally open output channel is a series connection of contacts from two forced-guided (mechanically linked) relays, K1-K2. The normally closed contact 31-32 is a parallel connection of contacts from K1-K2.</p> <p>Contacts: AgNi, 5 µm gold-plated</p> <p>Low Current Rating: The 5 µm gold-plated contacts allow the switching of low current/low voltage. In these low-power applications, multiple contacts can also be switched in series (e.g., “dry switching”). To preserve the gold plating on the contacts, do not exceed the following max. values at any time:</p> <table border="0"> <tr> <td>Min. voltage: 1V ac/dc</td> <td>Max. voltage: 60V</td> </tr> <tr> <td>Min. current: 5 mA ac/dc</td> <td>Max. current: 300 mA</td> </tr> <tr> <td>Min. power: 5 mW (5 mVA)</td> <td>Max. power: 7 W (7 VA)</td> </tr> </table> <p>High Current Rating: If higher loads must be switched through one or more of the contacts, the minimum and maximum values of the contact(s) changes to:</p> <table border="0"> <tr> <td>Minimum:</td> <td>Maximum:</td> </tr> <tr> <td>Voltage: 15V ac/dc</td> <td>250V ac / 24V dc, 6A resistive</td> </tr> <tr> <td>Current: 30 mA ac/dc</td> <td>Max. power: 150 W (1,500 VA)</td> </tr> <tr> <td>Power: 0.45 W (0.45 VA)</td> <td>IEC 60947-5-1:</td> </tr> <tr> <td></td> <td>AC-15: 230V ac, 3A; DC-13: 24V dc, 4A</td> </tr> </table> <p>Mechanical life: 20,000,000 operations Electrical life: 150,000 cycles @ 1,500 VA; 1,000,000 cycles @ 450 VA; 2,000,000 cycles @ 250 VA; 5,000,000 cycles @ 125 VA</p> <p>Feedback contact rating (Y1-Y2, Y3-Y4):</p> <table border="0"> <tr> <td>Min. voltage: 1V ac/dc</td> <td>Max. voltage: 60V</td> </tr> <tr> <td>Min. current: 5 mA ac/dc</td> <td>Max. current: 300 mA</td> </tr> <tr> <td>Min. power: 5 mW (5 mVA)</td> <td>Max. power: 7 W (7 VA)</td> </tr> </table> <p>Note: Transient suppression is recommended when switching inductive loads. Install suppressors across load. Never install suppressors across output contacts (see Warning, page 5).</p>	Min. voltage: 1V ac/dc	Max. voltage: 60V	Min. current: 5 mA ac/dc	Max. current: 300 mA	Min. power: 5 mW (5 mVA)	Max. power: 7 W (7 VA)	Minimum:	Maximum:	Voltage: 15V ac/dc	250V ac / 24V dc, 6A resistive	Current: 30 mA ac/dc	Max. power: 150 W (1,500 VA)	Power: 0.45 W (0.45 VA)	IEC 60947-5-1:		AC-15: 230V ac, 3A; DC-13: 24V dc, 4A	Min. voltage: 1V ac/dc	Max. voltage: 60V	Min. current: 5 mA ac/dc	Max. current: 300 mA	Min. power: 5 mW (5 mVA)	Max. power: 7 W (7 VA)
Min. voltage: 1V ac/dc	Max. voltage: 60V																						
Min. current: 5 mA ac/dc	Max. current: 300 mA																						
Min. power: 5 mW (5 mVA)	Max. power: 7 W (7 VA)																						
Minimum:	Maximum:																						
Voltage: 15V ac/dc	250V ac / 24V dc, 6A resistive																						
Current: 30 mA ac/dc	Max. power: 150 W (1,500 VA)																						
Power: 0.45 W (0.45 VA)	IEC 60947-5-1:																						
	AC-15: 230V ac, 3A; DC-13: 24V dc, 4A																						
Min. voltage: 1V ac/dc	Max. voltage: 60V																						
Min. current: 5 mA ac/dc	Max. current: 300 mA																						
Min. power: 5 mW (5 mVA)	Max. power: 7 W (7 VA)																						
Output Response Time	20 milliseconds maximum																						
Status Indicators	2 green LED indicators: K1 energized, K2 energized																						
Construction	Polycarbonate housing rated NEMA 1, IEC IP20																						
Mounting	Mounts to standard 35 mm DIN-rail track. Interface Module must be installed inside an enclosure rated NEMA 3 (IEC IP54), or better.																						
Vibration Resistance	10 to 55Hz @ 0.35 mm displacement per IEC 60068-2-6																						
Operating Conditions	Temperature: 0° to +50°C (+32° to 122°F) Max. Relative Humidity: 90% @ 50°C (non-condensing)																						
Dimensions	See Figure 10.																						
Design Standards	EN 60204-1, IEC 61810-1, EN 60255-1, EN 50205																						
Application Notes	There are no adjustments and no user-serviceable parts. See page 10 for information regarding repair service.																						
Certifications	 																						

Models IM-T-9A and IM-T-11A – Interface Modules

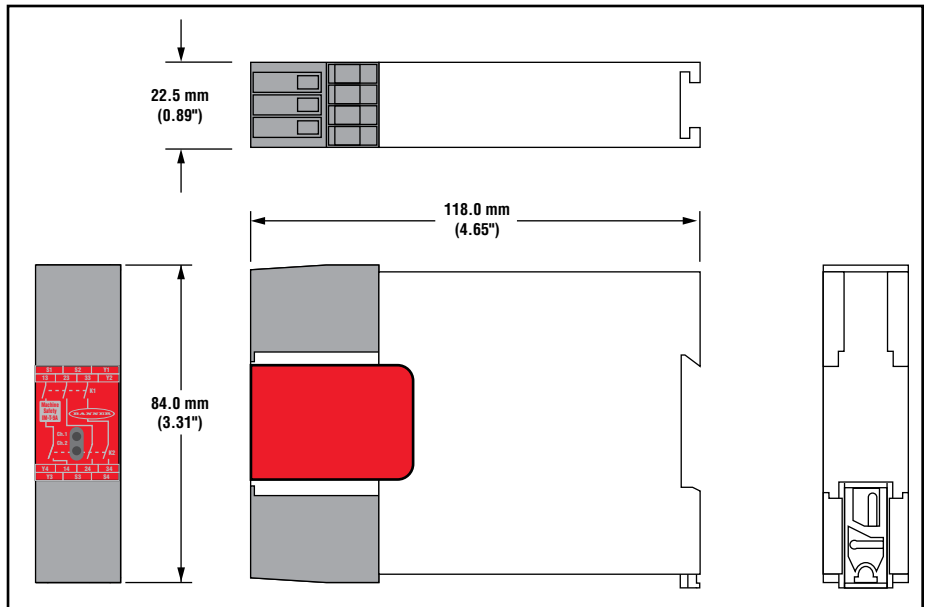

Figure 10. Interface Module enclosure dimensions

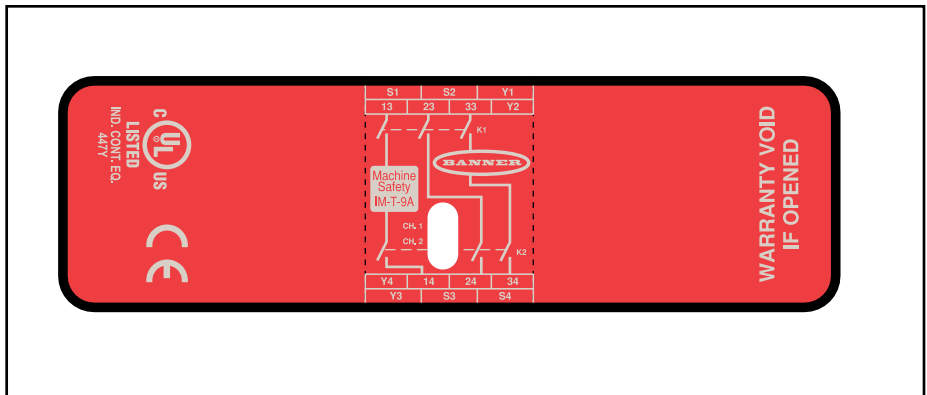

Figure 11. Interface Module label (model IM-T-9A shown)

Models IM-T-9A and IM-T-11A – Interface Modules

EC Declaration of Conformity

Banner Engineering Corp.

9714 Tenth Avenue North

Minneapolis, MN 55441-5019 USA

We herewith declare that IM-T-9A and IM-T-11A Interface Modules for industrial control are in conformity with the provisions of the Machinery Directive (Directive 98/37/EEC), and all essential Health and Safety Requirements have been met.



10/23/2009

R. Eagle / Engineering Manager

Date

Download the complete EC Declaration of Conformity as a PDF file at www.bannerengineering.com/Interfacemodule

For more information: Contact your local Banner representative or Banner Corporate Offices around the world.	Corporate Headquarters Banner Engineering Corp. 9714 Tenth Ave. North Mpls., MN 55441 Tel: 763-544-3164 www.bannerengineering.com sensors@bannerengineering.com	Europe Banner Engineering Europe Park Lane Culliganlaan 2F Diegem B-1831 BELGIUM Tel: 32-2 456 07 80 Fax: 32-2 456 07 89 www.bannereurope.com mail@bannereurope.com	Latin America Contact Banner Engineering Corp. (US) or e-mail Mexico: mexico@bannerengineering.com Brazil: brasil@bannerengineering.com
	Asia — China Banner Engineering China Shanghai Rep Office Rm.G/H/I, 28th Flr. Cross Region Plaza No. 899, Lingling Road Shanghai 200030 CHINA Tel: 86-21-54894500 Fax: 86-21-54894511 www.bannerengineering.com.cn sensors@bannerengineering.com.cn	Asia — Japan Banner Engineering Japan Cent-Urban Building 305 3-23-15 Nishi-Nakajima Yodogawa-Ku, Osaka 532-0011 JAPAN Tel: 81-6-6309-0411 Fax: 81-6-6309-0416 www.bannerengineering.co.jp mail@bannerengineering.co.jp	Asia Banner Engineering Asia — Taiwan Neihu Technology Park 5F-1, No. 51, Lane 35, Jihu Rd. Taipei 114 TAIWAN Tel: 886-2-8751-9966 Fax: 886-2-8751-2966 www.bannerengineering.com.tw info@bannerengineering.com.tw



WARRANTY: Banner Engineering Corp. warrants its products to be free from defects for one year. Banner Engineering Corp. will repair or replace, free of charge, any product of its manufacture found to be defective at the time it is returned to the factory during the warranty period. This warranty does not cover damage or liability for the improper application of Banner products. This warranty is in lieu of any other warranty either expressed or implied.

P/N 62822 rev. C