

MULTI-BEAM[®]

3- & 4-wire Fiber Optic Mode Scanner Blocks for MULTI-BEAM[®] Modular Photoelectric Sensors



A Banner MULTI-BEAM Sensor is a compact *modular* self-contained photoelectric switch consisting of three components: a scanner block, a power block, and a logic module. The *scanner block*, described in this data sheet, comprises the housing for the sensor and contains a complete modulated photoelectric amplifier, the emitter and/or receiver optoelements, and space for the other modules.

The *power block module* provides the interface between the scanner block and the external circuit. It contains a power supply for the MULTI-BEAM plus a switching device to interface the sensor to the circuit to be controlled. 3- and 4-wire dc power block modules operate from dc voltages and are discussed in data sheet 03499. 3- and 4-wire ac power blocks operate from ac voltages and are covered in data sheet 03501. The *logic module* (data sheet 03304) interconnects the power block and scanner block both electrically and mechanically. It provides the desired timing logic function (if any) plus the ability to program the output for either light- or dark-operate.

Power block and logic modules are purchased separately. This modular design, with field-replaceable power block and logic modules, permits a large variety of sensor configurations, resulting in exactly the right sensor for any fiber optic photoelectric application.

MULTI-BEAM 3- and 4-wire fiber optic mode scanner blocks include several different standard models. The high power models (those with 10 millisecond response time) offer the greatest optical sensing power of any industrial fiber optic sensors.

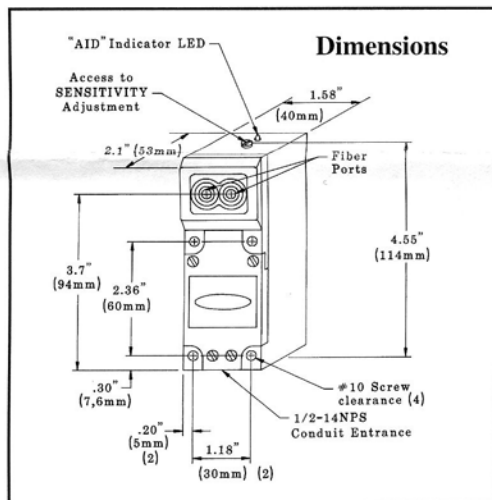
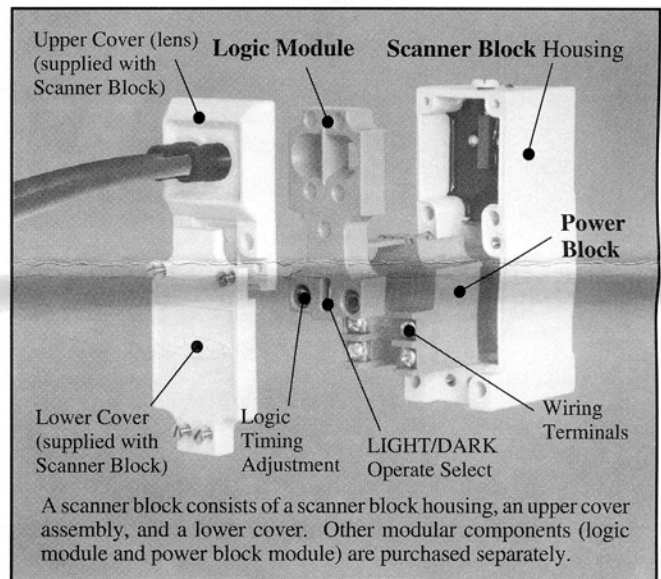

The circuitry of all MULTI-BEAM components is encapsulated within rugged, corrosion-resistant VALOX[®] housings that meet or exceed NEMA 1, 3, 12, and 13 ratings. MULTI-BEAM 3- and 4-wire fiber optic mode scanner blocks include Banner's exclusive, patented* Alignment Indicating Device (AID[™]) system, which lights a top-mounted LED when the sensor sees its modulated light source and pulses at a rate proportional to the strength of the received light signal.

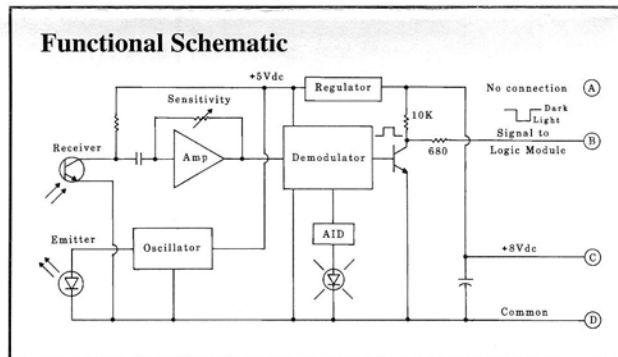

All MULTI-BEAM scanner blocks are totally solid-state for unlimited life.

*US patent 4356393.

Specifications (see also "Modifications", page 4)

Supply Voltage: Input power and output connections are made via 3- or 4-wire power blocks. See data sheet 03499 (DC Power Blocks) or 03501 (AC Power Blocks), or refer to the Banner product catalog.

Response Time (independent of signal strength):
 1 millisecond "on" and "off";
 High-gain models ("X" model suffix) 10 milliseconds "on" and "off";
 High-speed models ("MHS" model suffix) are 0.3 milliseconds "on" and "off".

Sensitivity Adjustment: Easily-accessible, located on top of scanner block beneath o-ring gasketed nylon screw cover. 15-turn clutched control; rotate clockwise to increase sensitivity.

Alignment Indicator: Red LED on top of scanner block. Banner's exclusive, patented Alignment Indicating Device (AID[™]) circuit lights the LED whenever the sensor detects its own modulated light source, and pulses the LED at a rate proportional to the received light level.

Construction: Reinforced VALOX[®] housing; components totally encapsulated. Stainless steel hardware. Meets NEMA standards 1, 3, 12, and 13.

Operating Temperature Range: -40 to +70° C (-40 to +158° F).



WARNING These photoelectric presence sensors do NOT include the self-checking redundant circuitry necessary to allow their use in personnel safety applications. A sensor failure or malfunction can result in either an energized or a de-energized sensor output condition.

Never use these products as sensing devices for personnel protection. Their use as safety devices may create an unsafe condition which could lead to serious injury or death.

Only MACHINE-GUARD and PERIMETER-GUARD Systems, and other systems so designated, are designed to meet OSHA and ANSI machine safety standards for point-of-operation guarding devices. No other Banner sensors or controls are designed to meet these standards, and they must NOT be used as sensing devices for personnel protection.

MULTI-BEAM 3- & 4-wire fiberoptic scanner blocks

FIBEROPTIC Scanner Blocks

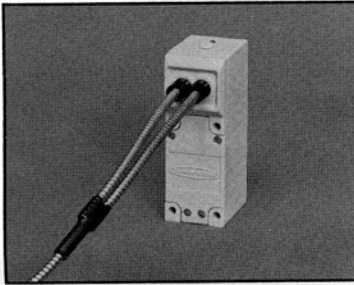

Fiberoptic mode MULTI-BEAMS are used with Banner's extensive selection of glass fiberoptics to allow sensing in areas too "tight" or otherwise too environmentally hostile to the scanner block itself. In addition, the fiber bundle of a glass fiberoptic assembly may be shaped at the sensing tip to exactly match the profile of the object to be sensed.

The Banner product catalog contains complete descriptions of all standard glass fiberoptic models, as well as examples of special custom fiberoptic designs. Banner welcomes your special fiberoptic sensing application requirements.

NOTE: the fiberoptic gain curves printed in this data sheet apply to 3-foot fiber lengths. Excess gain decreases by approximately 10% for each additional foot of fiberoptic cable.

SBEF/SBRF and SBEXF/SBRXF pairs, OPPOSED MODE:

Models SBFX1, SBF1, SBF1MHS, SBFV1, OPPOSED MODE:

Models SBF1, SBFV1, RETROREFLECTIVE MODE:

Models SBFX1, SBF1, SBF1MHS, SBFV1, SBFVG1, DIFFUSE MODE:

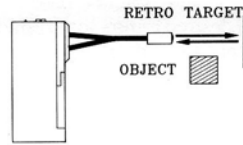
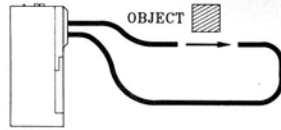

Excess Gain

Beam Pattern

Excess Gain

Beam Pattern

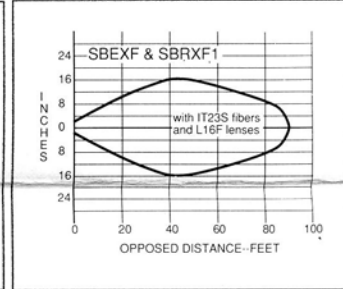
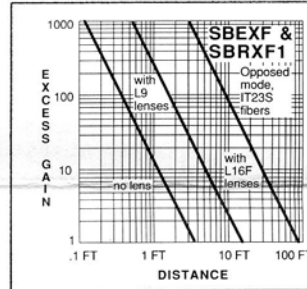
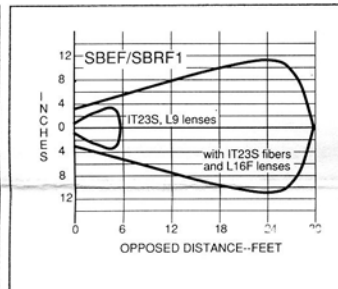
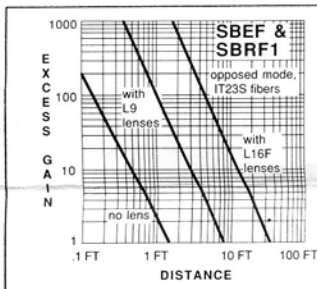

models SBEF & SBRF1

Range: see excess gain curve
Response: 1ms on/off
Beam: infrared, 880nm

SBEF & SBRF1: use with individual glass fiberoptic assemblies in lieu of model SBF1 where it is inconvenient to run fibers from a single scanner block.

models SBEXF & SBRXF1

Range: see excess gain curve
Response: 10ms on/off
Beam: infrared, 880nm

SBEXF & SBRXF1: use in place of model SBFX1 (shown below) for long-range opposed fiberoptic sensing. Or use where high excess gain is required and it is difficult to run the fibers to both sides of the process from a single scanner block.

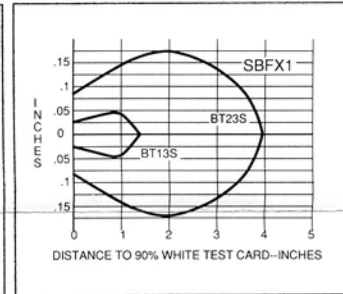
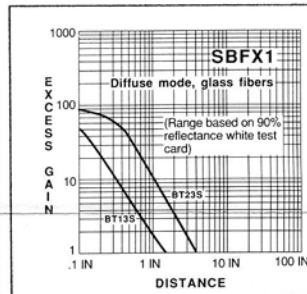
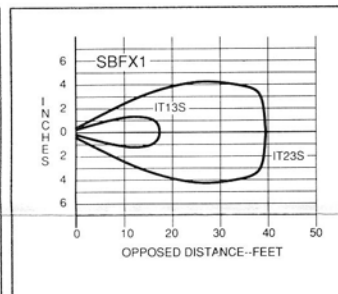
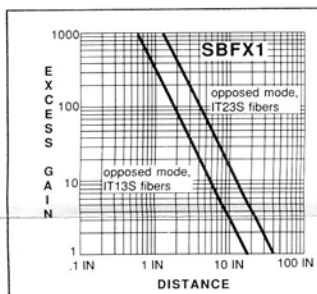

model SBFX1

Range: see excess gain curves
Response: 10ms on/off
Beam: infrared, 880nm

Model SBFX1 is the first choice for glass fiberoptic applications, except in fiberoptic retroreflective applications or where faster response speed or visible light are a requirement. Model SBFX1 contains both emitter and receiver and thus accepts either one bifurcated fiberoptic assembly or two individual fiberoptic cables.

The excess gain of model SBFX1 is the highest available in the photoelectric industry. As a result, opposed individual fibers operate reliably in many very hostile environments. Also, special miniature bifurcated fiberoptic assemblies with bundle sizes as small as .020 inch (.5mm) in diameter may be used successfully with model SBFX1 for diffuse mode sensing. The excess gain curves and beam patterns illustrate response with standard .060 inch (1.5mm) diameter and .12 inch (3mm) diameter bundles. Response for smaller or larger bundle sizes may be interpolated. NOTE: opposed ranges shown are meant to illustrate excess gain only, and are limited by fiber length. Use scanner block models SBEXF and SBRXF1 (above) for long range opposed fiberoptic sensing.

MULTI-BEAM 3- & 4-wire fiberoptic scanner blocks

Excess Gain

Beam Pattern

model SBFV1

VISIBLE RED LIGHT SOURCE

Range: see excess gain curves

Response: 1ms on/off

Beam: visible red, 650nm

Scanner block model SBFV1 supplies visible red light to the emitter half of a glass fiberoptic photoelectric system. Visible light sensors have less optical energy as compared to infrared systems. There are, however, some sensing situations which require visible light wavelengths in order to realize adequate optical contrast.

Opposed fibers using visible red light are used to reliably sense translucent materials (e.g. plastic bottles) which appear transparent to infrared opposed sensors. Fiber assembly model BT13S used with a model L9 or L16F lens makes an excellent visible light sensing system for retroreflective code reading as well as for many short-range retroreflective applications (e.g. retro sensing across a narrow conveyor).

When combined with a bifurcated fiber, model SBFV1 may be used for color registration sensing for applications where there is a large difference between the two colors (e.g. black-on-white). For combinations of red-on-white, however, the visible-green light source of model SBFVG1 (below) is needed. Visible light emitters are also helpful for visual system alignment and maintenance.

COMMONLY USED FIBEROPTICS AND LENSES:

The following fiberoptic cables and lenses are commonly used with the sensors described in this data sheet. Many other models are available. See the Banner product catalog for complete details.

IT13S: individual assembly .06 in. (1.5mm) diameter fiber bundle

IT23S: individual assembly .12 in. (3mm) diameter fiber bundle

BT13S: bifurcated assembly, .06 in. (1.5mm) diameter fiber bundle

BT23S: bifurcated assembly, .12 in. (3mm) diameter fiber bundle

L9: .5in. (12mm) dia. lens

L16F: 1.0 in. (25mm) dia. lens

VISIBLE GREEN LIGHT SOURCE for COLOR SENSING (REGISTRATION CONTROL)

model SBFVG1

Range: see excess gain curve

Response: 1 ms on/off

Beam: visible green, 560nm

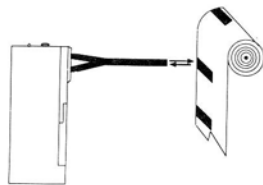

Convergent beam sensors like model SBCVG1 are often used for color registration sensing. However, there are some registration applications where the use of bifurcated fiber optics is beneficial. Fiber optics are able to fit into tight locations which are too small for a convergent sensor.

Fibers also allow a choice of image size. It is important to create an image size which is smaller than the registration mark in order to

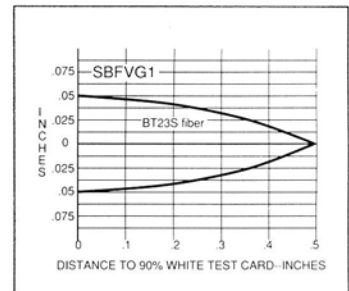
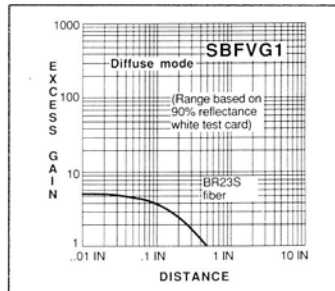
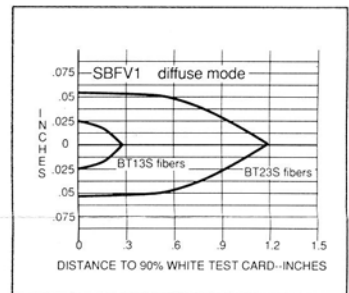
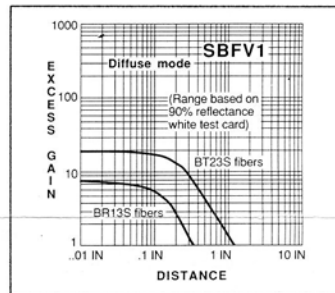
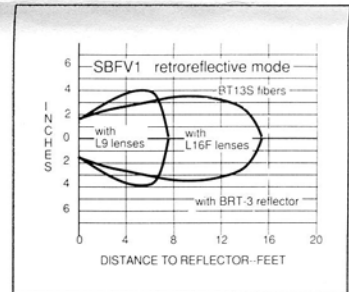
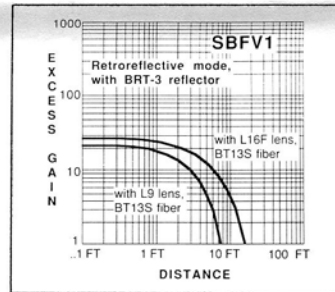
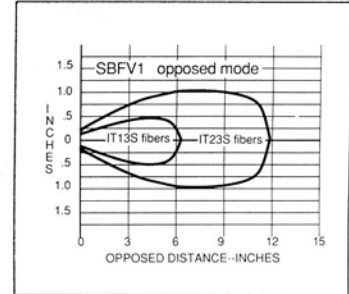
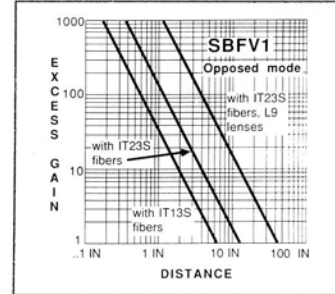

maximize optical contrast and to ease sensor response requirements. Fibers allow a match of the light image to the geometry of the registration mark. Scanner block model SBFVG1 will sense most bold color differences, including red-on-white. Use only power blocks which switch DC (e.g. PBT, PBP, PBO, PBAT, etc.) for fast response.

About Banner's Alignment Indicating Device (AID™) System:

"AID" (Alignment Indicating Device, US patent #4356393) is an exclusive built-in feature that permits optimum alignment and continuous monitoring of the photoelectric system. The red receiver LED indicator is "on" when the receiver "sees" the modulated light from the emitter LED and "off" when the beam is broken. In addition, a low frequency pulse rate is superimposed on the LED indicator. When alignment is marginal, the pulse rate will be about once per second (indicating an excess gain of 1). As alignment is improved, the pulse rate increases, indicating increased excess gain. Optimum sensor alignment is indicated by the fastest pulse rate.

The AID feature will also tell you when maintenance is necessary. Any pulse rate less than two per second indicates marginal performance; the unit, however, is still functioning properly. When the pulse rate slows to less than 2 per second, lenses should be cleaned and alignment checked.

MULTI-BEAM 3- & 4-wire fiberoptic scanner blocks

model SBF1 HIGH-SPEED SCANNER BLOCK

Range: see excess gain curves

Response: 1ms on/off

Beam: infrared, 940nm

Fiberoptics are often used to sense small parts. Small parts or narrow profiles which move at a high rate of speed can require sensors with fast response times for reliable detection. High speed fiberoptic sensors are ideal for sensing gear or sprocket teeth or other targets in applications involving counters or shift registers for position control.

Selection of the fiberoptic sensing tip should involve matching the effective beam of the fiber to the profile of the part to be sensed to maximize the time that the part is sensed and/or the time between adjacent parts. Combining the best selection of fiber tip geometry with a high speed sensor will result in a highly repeatable position sensing system.

The model BT13S fiberoptic assembly used with a model L9 or L16F lens and a high speed scanner block is an excellent system for retro-reflective code reading or for almost any short range retroreflective sensing application. Response time of a MULTI-BEAM sensor is also a function of the power block. For this reason, only power blocks which switch DC (e.g. PBT, PBP, PBO, PBAT, etc) should be used if the fast response time of the scanner block is to be taken advantage of.

COMMONLY USED FIBEROPTICS AND LENSES:

The following fiberoptic cables and lenses are commonly used with the sensors described in this data sheet. Many other models are available. See the Banner product catalog for complete details.

IT13S: individual assembly .06 in. (1.5mm) diameter fiber bundle

IT23S: individual assembly .12 in. (3mm) diameter fiber bundle

BT13S: bifurcated assembly, .06 in. (1.5mm) diameter fiber bundle

BT23S: bifurcated assembly, .12 in. (3mm) diameter fiber bundle

L9: .5in. (12mm) dia. lens

L16F: 1.0 in. (25mm) dia. lens

Excess Gain

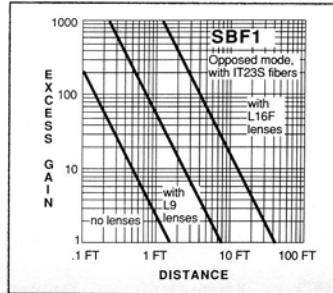

Beam Pattern

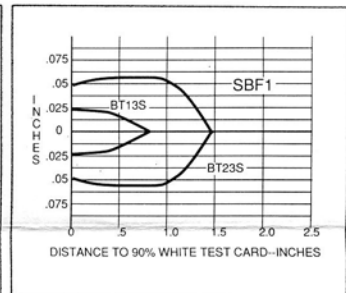
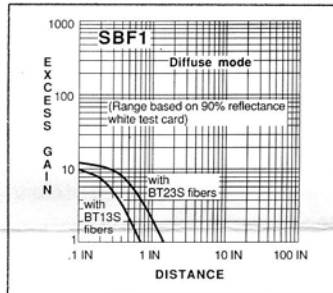
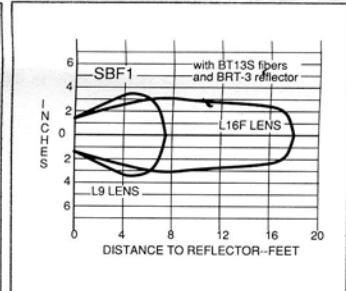
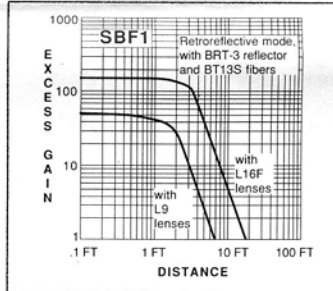
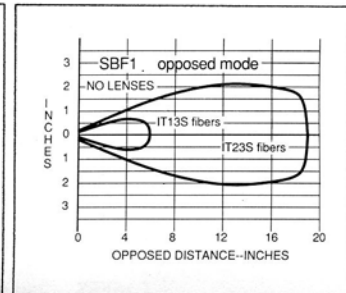

model SBF1MHS

Range: see excess gain curves

Response: 300 microseconds on/off

Beam: infrared, 940nm

VERY HIGH-SPEED SCANNER BLOCK

SBF1MHS is the model SBF1 modified for high-speed (300 microsecond) response. It may be used in either fiberoptic opposed (below left) or fiberoptic diffuse mode (below right). Note that the faster response comes at the expense of lower gain (see excess gain curves for both models and note on "MHS" modification, below).

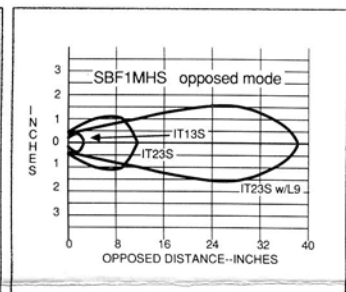
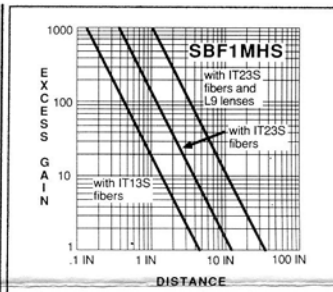
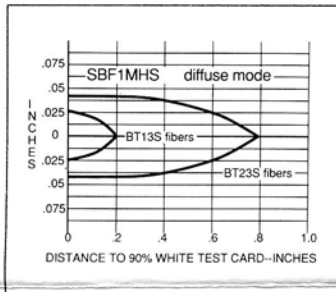
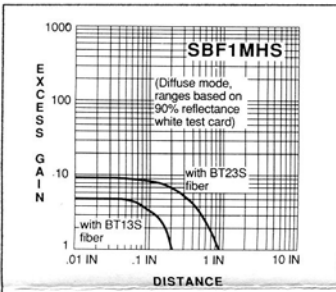

MULTI-BEAM Scanner Block Modifications

The following are popular modifications to MULTI-BEAM 3- & 4-wire scanner blocks. They are not stocked, but are available on a quote basis.

ZERO HYSTERESIS MODIFICATION "MZ": amplifier hysteresis may be removed from 3- and 4-wire scanner blocks when attempting to sense very small signal changes (contrasts less than 3). This modification is designated by adding suffix "MZ" (Modified Zero Hysteresis). Be sure that all variables affecting the sensor's optical response remain constant before ordering the zero hysteresis modification.

HIGH SPEED MODIFICATION "MHS": scanner blocks with 1 millisecond response may be modified for 300 microsecond (0.3 millisecond) response. This modification is designated by adding suffix "MHS" to the scanner block model number (e.g.- SBF1MHS, etc.). The MHS modification reduces the available excess gain by about 50%, and also decreases the sensor's immunity to some forms of electrical "noise".

INSTALLATION AND ALIGNMENT

ATTACHMENT OF LENS ASSEMBLY

Lenses are sometimes added to fiberoptic assemblies for extending opposed sensing range or for retroreflective mode sensing. Banner offers the following lens assemblies for use with fiberoptic assemblies having 5/16"-24 threaded sensing end tips:

MODEL	LENS SIZE	FOCAL LENGTH	HOUSING	NOTES
L9	12,5mm (1/2")	12,5mm (1/2")	Aluminum	Suitable for all but highly corrosive environments
L16F	25mm (1")	44mm (1.7")	Delrin	Maximum operating temperature is 100°C (212°F)
L16FAL	25mm (1")	44mm (1.7")	Aluminum	Suitable for all but highly corrosive environments
L16FSS	25mm (1")	44mm (1.7")	Stainless steel	Suitable for all environments

Lenses are most efficient when they are located slightly beyond their focal length distance from the sensing end of the fiberoptic bundle. The easiest way of focusing a lens is to treat it like a magnifying glass.

Illuminate the bundle at the threaded end of the fiberoptic assembly by holding the opposite end toward a visible light source (e.g. - incandescent bulb, visible LED, sunlight, etc.). Thread the lens assembly onto the fiberoptic assembly until the end of the fiberoptic bundle comes into sharp focus under the lens. Finally, back-off (unthread) the lens assembly from the point of the sharpest focus by one to three full turns. The illuminated bundle should now appear slightly blurred. Refer to the drawing at the right.

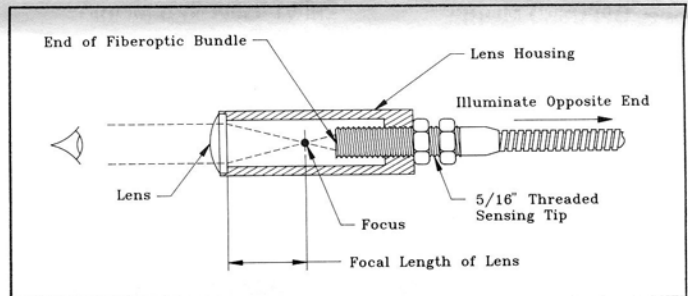

ALIGNMENT PROCEDURE

NOTES:

- 1) The Alignment Indicating Device (AID™) LED on the top of the sensor is used in the following alignment procedures.
- 2) Apply power to the MULTI-BEAM power block at terminals #1 and #2. See hookup information which is packed with the powerblock.
- 3) The sensitivity control, located beneath the nylon cover screw at the top of the scanner block, is a 15-turn potentiometer, clutched at both ends. Use a small, flat-blade screwdriver for adjustment.

OPPOSED MODE SENSING:

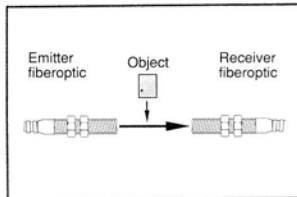

To align two individual fiberoptic assemblies for opposed mode sensing, begin with one sensing tip mounted firmly in place. The opposite fiber is moved up-down-left-right to find the position where the Alignment Indicating Device LED is pulsing at the fastest rate. Include *angular* movement

during alignment. Find the center of the area of movement where the LED is "on" steadily, or reduce the sensitivity (CCW rotation of sensitivity control) to obtain a "countable" pulse rate. Secure the fiberoptic sensing tip in the optimum position.

Unlensed fiberoptics are easiest to align. Opposed fiberoptics with large bundles (e.g. - 1/8" diameter) usually require only line-of-sight alignment when used at opposed distances up to a few inches. Alignment requires more positioning accuracy when a lens is added on one side of the process. The requirement for alignment accuracy is even greater when lenses are used on both fiber assemblies.

Increase the sensitivity of the scanner block to maximum by rotating the sensitivity control 15 or more turns, clockwise. Place the object to be detected in the center of the beam at the sensing location. If the alignment indicator LED goes "off", alignment is complete. Check operation by alternately removing and replacing the object. The LED should follow the action by coming "on" when the object is absent and going "off" when the object is present.

NOTE: If the alignment indicator stays "on" when the object is present at the sensing position, the cause may be one of the following:

a) **Small Parts:** The width of the object in the beam must be greater than the diameter of the fiber bundles or lenses. If the effective beam is too large to sense the object, consider smaller fiber bundle diameters or substitute fiberoptic assemblies with *rectangular* bundle terminations. Make certain that small parts are accurately placed in the center of the beam at the time they are to be detected.

b) **Transparent Materials:** Thin-walled and transparent materials may pass some of the light energy. In fact, some thin-walled plastics which appear opaque may easily pass infrared light. With the part in place, reduce the sensitivity (CCW rotation of sensitivity control) until the alignment LED goes "off", plus two more full turns. Remove the object and verify that the Alignment Indicating Device LED is on steadily or pulsing faster than two beats per second. If this adjustment fails, consider sensing the object by diffuse mode or by another sensing scheme.

DIFFUSE MODE SENSING:

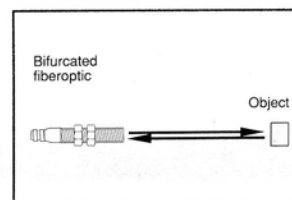

Bifurcated fiberoptic assemblies are used for diffuse mode sensing. Additionally, two individual fibers may be positioned side-by-side and mechanically converged toward the sensing location. This scheme doubles the amount of fiber area used to transmit and receive light and yields more sensing

range and/or excess gain than is specified on a diffuse mode excess gain curve. The diffuse mode is used for either object presence sensing or for color mark sensing:

a) **Object Presence Sensing:** Mount the fiberoptic sensing tip as close as possible to the object to be detected. Increase the sensitivity of the scanner block to maximum by rotating the sensitivity control 15 or more turns clockwise. Place the object to be detected in the sensing position. The Alignment Indicator Device LED should be "on" steadily or pulsing faster than two beats per second. If the LED does not come "on", or if the AID pulse rate is very slow, reposition the fiber tip closer to the object. If repositioning is not possible, consider substituting a bifurcated fiberoptic assembly with a larger bundle diameter or using two individual fiberoptic assemblies, mechanically converged towards the object.

Remove the object from the sensing location. If the alignment LED goes "off", alignment is complete. Check operation by alternately removing and replacing the object at the sensing location. The alignment LED should follow the action by coming "on" when the object is present and going "off" when the object is absent.

NOTE: If the alignment LED remains "on" when the object is removed, reduce the scanner block sensitivity (CCW rotation of sensitivity control) until the LED goes "off", plus two more full turns. Replace the object in the sensing position, and verify that the alignment LED comes "on" steadily or is pulsing faster than two beats per second. If this adjustment fails, consider methods of suppressing the reflections from background surfaces. Also, check the bifurcated fiberoptic assembly for fiber breakage. Fiber breakage is evidenced by light returned to the scanner block (indicator LED "on") when the fiberoptic assembly is pointed away from all reflecting surfaces.

b) Color Mark Sensing: Scanner block models SBFV1 (red LED) and SBFVG1 (green LED) are used with a bifurcated fiberoptic assembly to sense color differences. Their most common application is color mark sensing on printed webs. The random mix of transmit and receive fibers in a bifurcated fiberoptic assembly is ideal for sensing color differences. Additionally, the bundle can be sized and/or shaped to exactly match a particular color registration mark.

Position the darker of the two colors directly under the sensing tip of the bifurcated fiberoptic assembly so that the visible image is completely contained within the boundaries of the dark area. Increase the sensitivity of the scannerblock (CW rotation of the sensitivity control) until the alignment indicator LED just goes "on". Decrease the sensitivity (CCW rotation) until the alignment LED goes "off", plus two full turns. Present the lighter of the two colors to the visible image. Verify that the indicator LED comes "on" steadily or is pulsing faster than two beats per second. Check operation by alternating the dark and light colors under the sensing tip. The alignment LED should follow the action by coming "on" with the light color and going "off" with the dark color.

NOTE: Shiny materials should be sensed at a skew angle to avoid direct reflections which might reduce optical contrast between colors. Clear materials, like poly webs, may require opposed sensing of printed marks. Scanner block model SBFVG1 is required for red-on-white and similar color differences.

RETROREFLECTIVE SENSING:

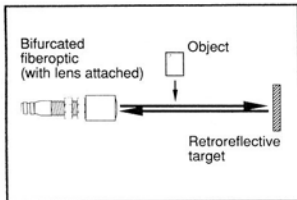

Scanner block models SBF1, SBF1MHS, or SBFV1 are used with a BT13S fiber and an L9 or L16F lens assembly for retroreflective sensing. Unlike most two-lens retroreflective sensing designs, a bifurcated fiberoptic/lens combination has no *minimum* sensing distance. As a result, this

combination is an excellent choice for retroreflective sensing across small parts conveyors or for high-speed retroreflective code reading applications.

Follow the procedure outlined on page 5 for attachment and focusing of a lens to the BT13S fiberoptic assembly. Mount the fiber sensing assembly securely in place. Present the retroreflective target to the sensor and find the center of the sensing area by moving the target up-down-left-right.

a) Part Present Applications: Install the retroreflective material in the center of the sensing beam. Increase the sensitivity of the scannerblock to maximum by rotating the sensitivity control 15 or more turns clockwise. Place the object in the sensing position. If the alignment

LED goes "off", alignment is complete. Check operation by alternately removing and replacing the object from the sensing location. The alignment LED should follow the action by coming "on" when the object is absent and going "off" when the object is present.

NOTE: If the alignment LED remains "on" when the object is present at the sensing position, the sensor is reacting to light that is being reflected directly from the object or from the backside of the lens (i.e. - "proxing" is taking place). Reduce the sensitivity (CCW rotation of the sensitivity control) until the alignment LED goes "off", plus two more full turns. Remove the object from the sensing position, and verify that the alignment LED comes "on" steadily or is pulsing at a rate faster than two beats per second. If this adjustment fails, consider the following:

Skew angle: If the object presents a flat, shiny surface, mount the fiber sensing end tip and the retroreflective target so that the light beam strikes the object's surface at an angle. Angles of about 10 degrees (or more) are often sufficient. This eliminates undesirable direct reflections from the object.

Lens focus: Check the focusing of the lens on the fiber tip as outlined on the top of page 5. An unfocused lens can cause false light return to the receive fibers *directly from the backside of the lens*.

Broken fibers: When the individual fiber strands within a bifurcated bundle break, light is "spilled", and some may be falsely returned to the receiver. This "cross-coupling" of light energy within a fiberoptic assembly is evidenced by the alignment indicator LED remaining "on" when the fiberoptic assembly is pointed away from all reflecting surfaces. Remove the lens assembly from the sensing tip for this test.

b) Code Reading Applications: Position the code plate so that a retroreflective code mark is in the center of the sensing beam. Increase the sensitivity of the scannerblock to maximum by rotating the sensitivity control 15 or more turns clockwise. Move the code plate so that the retroreflective code mark is outside of the sensing beam. If the alignment LED goes "off", alignment is complete. Check operation by moving the code plate back and forth. The alignment LED should follow the action by coming "on" when the code mark is present and going "off" when the code mark is absent. **NOTE:** if the alignment LED remains "on" when the retroreflective code mark is moved out of the sensing beam, reduce the scanner block sensitivity (turn sensitivity control CCW) until the LED goes "off", plus two more full turns. Move a code mark back into the sensing beam to verify that the alignment LED comes "on" steadily or is pulsing faster than two beats per second. If the surface of the code plate is shiny, position the fiberoptic sensing tip assembly to view the code plate and code marks at a "skew" angle.

FINAL ADJUSTMENT AND TEST: When alignment is completed, finish wiring the scannerblock by connecting the load to the output circuit of the powerblock (terminal #3 and/or #4). Refer to the hookup information for the power block in use (packed with power block). Check the operation of the load by alternately simulating the light and the dark conditions at the sensing end tip. The load and the alignment indicator LED should follow the action. Adjust the logic module timing (if any), as required.

NOTE: Logic modules (except models LM1, LM2, and LM10) include a light/dark programming jumper. Removing the jumper will invert the output state of the power block from normally open to normally closed, or vice versa. *Caution: do not attempt to remove the programming jumper while power is applied to the MULTI-BEAM!*

If you experience any difficulties with the installation of your fiberoptic sensing system, please contact your local Banner sales engineer or the Applications Department at the factory during normal business hours.

WARRANTY: Banner Engineering Corporation warrants its products to be free of defects for one year. Banner Engineering Corporation will repair or replace, without charge, any product of its manufacture found to be defective at the time it is returned to the factory during the warranty period. This warranty does not cover damage or liability for the improper application of Banner products. This warranty is in lieu of any other warranty either expressed or implied.