

# Incremental encoders

## Solid shaft with clamping or synchro flange

### 64...2048 pulses per revolution

#### BRIV 58K, BRIV 58S - EcoMag



BRIV 58K with clamping flange

#### Features

- Encoder with solid shaft  $\varnothing 10$  mm or  $\varnothing 6$  mm
- Magnetic sensing
- Max. 2048 pulses per revolution
- High resistance to shock and vibrations
- High limit frequency
- Clamping or synchro flange

#### Technical data - electrical ratings

Voltage supply	5 VDC $\pm 10$ % 10...30 VDC
Consumption w/o load typ.	30 mA (5 VDC) 15 mA (24 VDC)
Pulses per revolution	64...2048
Reference signal	Zero pulse, width 90°
Sensing method	Magnetic
Output frequency	$\leq 320$ kHz
Output signals	A 90° B, N + inverted
Output stage	Antivalent Push-pull short-circuit proof
Interference immunity	DIN EN 61000-6-2
Emitted interference	DIN EN 61000-6-3
Approval	UL approval / E217823

#### Technical data - mechanical design

Size (flange)	$\varnothing 58$ mm
Protection DIN EN 60529	IP 42, IP 65
Operating speed	$\leq 12000$ rpm (IP 42) $\leq 6000$ rpm (IP 65)
Operating torque typ.	0.0175 Nm (IP 42) 0.047 Nm (IP 65)
Materials	Housing: aluminium Flange: aluminium
Operating temperature	-20...+85 °C
Relative humidity	95 % non-condensing
Resistance	DIN EN 60068-2-6 Vibration 30 g, 10-2000 Hz DIN EN 60068-2-27 Shock 500 g, 6 ms
Connection	Connector M12, 5-pin Connector M12, 8-pin Connector M23, 12-pin Cable 2 m
Weight approx.	150 g

#### BRIV 58K

Shaft type	$\varnothing 10$ mm solid shaft (clamping flange)
Shaft loading	$\leq 40$ N axial $\leq 60$ N radial
Flange	Clamping flange

#### BRIV 58S

Shaft type	$\varnothing 6$ mm solid shaft (synchro flange)
Shaft loading	$\leq 40$ N axial $\leq 50$ N radial
Flange	Synchro flange

# Incremental encoders

## Solid shaft with clamping or synchro flange

### 64...2048 pulses per revolution

BRIV 58K, BRIV 58S - EcoMag

#### Part number

#### Clamping flange

BRIV 58K16

Connection  
 5 Cable 2 m, radial  
 A Connector M23, radial  
 N Connector M12, radial

Solid shaft  
 10 ø10 mm, IP 42  
 C0 ø10 mm, IP 65

Pulse number - see table

Voltage supply / signals

05A 5 VDC / antivalent (TTL compatible)  
 24K 10...30 VDC / push-pull short-circuit proof

#### Synchro flange

BRIV 58S16

Connection  
 5 Cable 2 m, radial  
 A Connector M23, radial  
 N Connector M12, radial

Solid shaft  
 06 ø6 mm, IP 42  
 C6 ø6 mm, IP 65

Pulse number - see table

Voltage supply / signals

05A 5 VDC / antivalent (TTL compatible)  
 24K 10...30 VDC / push-pull short-circuit proof

#### Pulse number

64	512	1024	2000
360	1000	1800	2048

Other pulse numbers on request.

#### Trigger level

Outputs 05A	Complementary Linedriver RS422
Output level High	>2,4 V (I = -20 mA)
Output level Low	<0,4 V (I = 20 mA)
Load High	<20 mA
Load Low	<20 mA
Outputs 24K	Push-pull short-circuit protection
Output level High	>+Vs - 3,7 V (I = -30 mA)
Output level Low	<2,5 V (I = 30 mA)
Load High	<30 mA
Load Low	<30 mA

#### Accessories

##### Connectors and cables

10107687	Female connector M23, 12-pin, straight
10130367	Female connector M23, 12-pin, straight, 2 m cable
10118532	Female connector M23, 12-pin, straight, 5 m cable
10146775	Female connector M12, 8-pin, straight
10127844	Female connector M12, 8-pin, straight, shielded, 2 m
10129332	Female connector M12, 8-pin, straight, shielded, 5 m cable
10153968	Female connector M12, 5-pin, straight
11046264	Female connector M12, 5-pin, straight, shielded, 2 m
11046266	Female connector M12, 5-pin, straight, shielded, 5 m

##### Mounting accessories for BRIV 58K

10252773	Clamp set ø15 mm
11053277	Bellows coupling aluminium/stainless steel 10 mm

##### Mounting accessories for BRIV 58S

10252773	Clamp set ø15 mm
----------	------------------

# Incremental encoders

## Solid shaft with clamping or synchro flange

### 64...2048 pulses per revolution

#### BRIV 58K, BRIV 58S - EcoMag

#### Terminal assignment

##### Cable

for connection reference -5

05A		24K	
Core colour	Signals	Core colour	Signals
brown	+Vs	brown	+Vs
green	CHA	green	CHA
red	CHA comp.	–	–
yellow	CHB	yellow	CHB
blue	CHB comp.	–	–
pink	CHN	pink	CHN
grey	CHN comp.	–	–
white	0 V	white	0 V
Cable data	8 x 0.14 mm <sup>2</sup>	5 x 0.14 mm <sup>2</sup>	
Screen	connected to housing		

##### Connector M23, 12-pin

for connection reference -A

05A, 24K	
Connector	Signals
Pin 1	CHA comp.
Pin 2	+Vs
Pin 3	CHN
Pin 4	CHN comp.
Pin 5	CHB
Pin 6	CHB comp.
Pin 7	n.c.
Pin 8	CHA
Pin 9	Housing
Pin 10	0 V
Pin 11 -12	n.c.

#### Output signals

Counter clockwise rotating direction when looking at the flange.

##### 05A

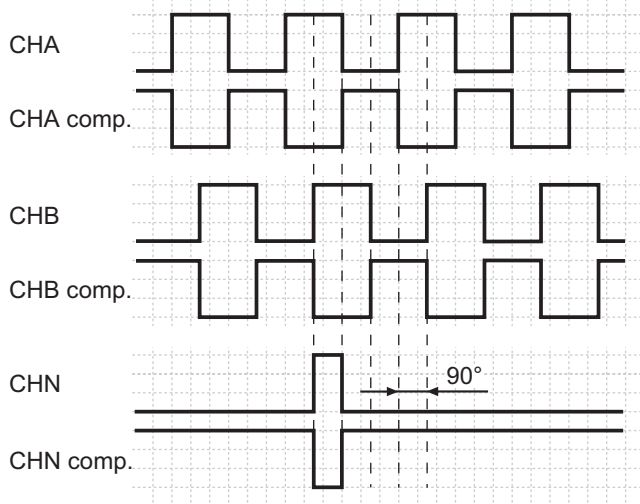

Counter clockwise rotating direction when looking at the flange.

##### 24K

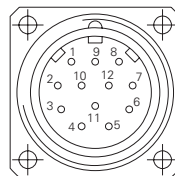
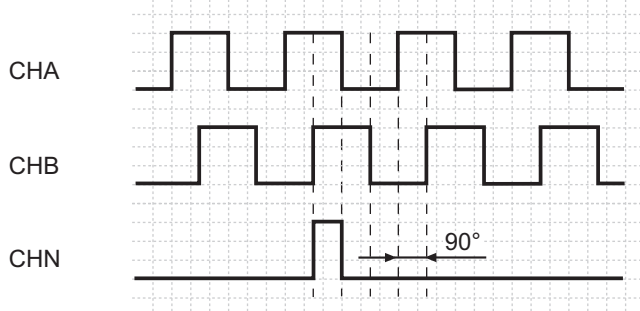

##### Connector M12, 8-pin / 5-pin

for connection reference -N

05A		
Connector	Core colour*	Signals
Pin 1	white	0 V
Pin 2	brown	+Vs
Pin 3	green	CHA
Pin 4	yellow	CHB
Pin 5	grey	CHN inv.
Pin 6	pink	CHN
Pin 7	blue	CHB inv.
Pin 8	red	CHA inv.

##### 24K

Connector	Core colour*	Signals
Pin 1	brown	+Vs
Pin 2	white	0 V
Pin 3	blue	CHA
Pin 4	black	CHB
Pin 5	grey	CHN

\*valid for the assembled mating connectors (see access.)



# Incremental encoders

## Solid shaft with clamping or synchro flange

### 64...2048 pulses per revolution

BRIV 58K, BRIV 58S - EcoMag

#### Dimensions

BRIV 58 clamping flange, cable radial

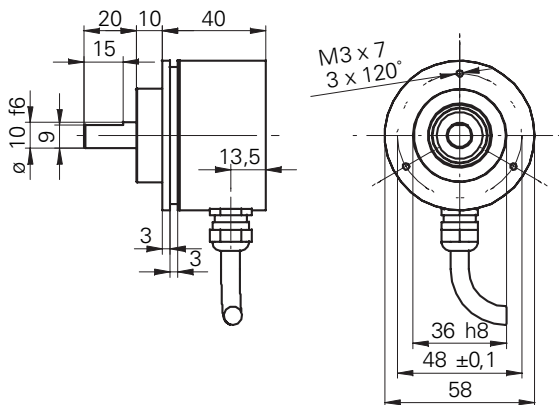

BRIV 58 clamping flange, connector output M23 radial

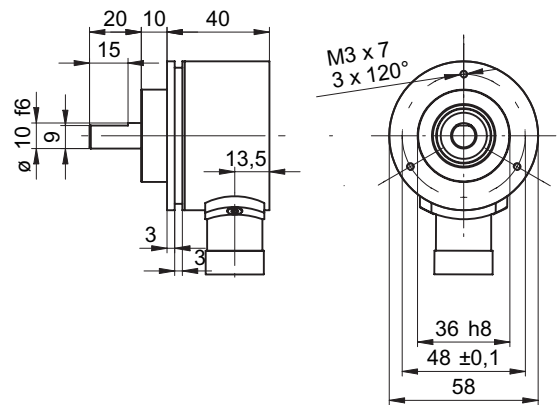

BRIV 58 clamping flange, connector output M12 radial

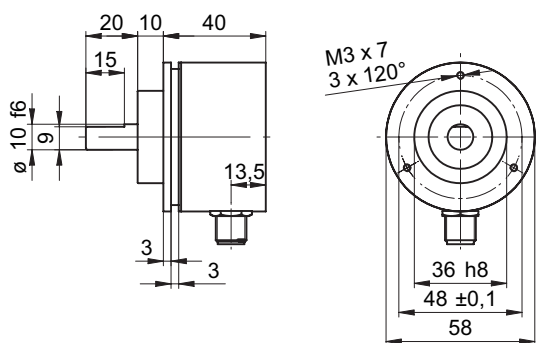

BRIV 58 synchro flange, cable radial

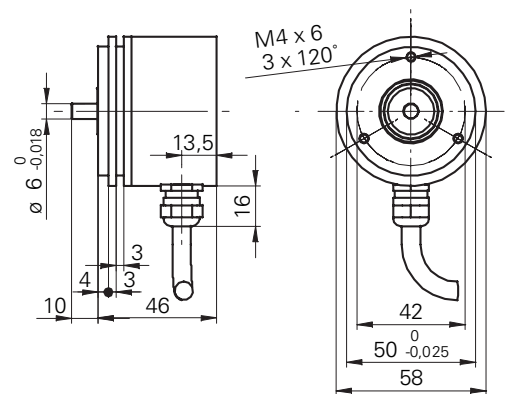

BRIV 58 synchro flange, connector output M23 radial

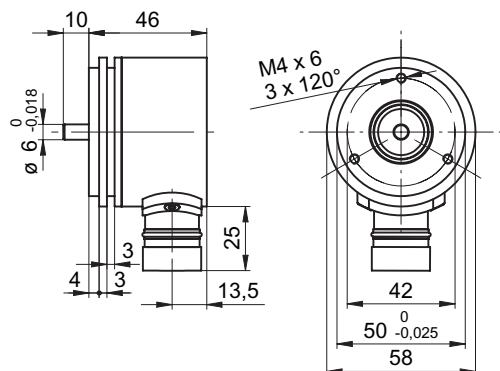

BRIV 58 clamping flange, connector output M12 radial

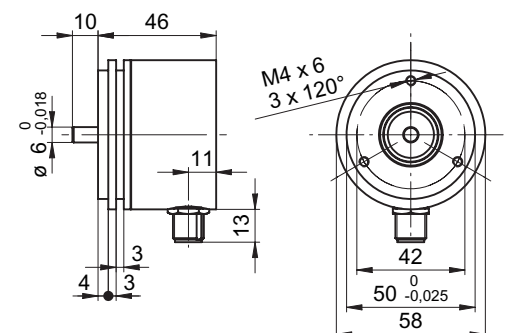

Subject to modification in technic and design. Errors and omissions excepted.