

TF SERIES HAND SET TIMER

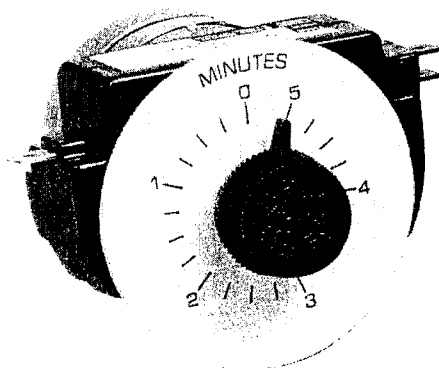

The TF Series Timer is a low cost, manually set, synchronous motor driven timer, adjustable to a selected time interval by a pointer knob. The TF is available in 6 time ranges from 1 minute to 11 hours.

The TF panel mounts in a single 3/8" diameter hole with a 3/8 x 32 nut. The TF has a completely moulded housing containing the reduction gears, motor mounting clips, and contact members. Terminations of contact members are 1/4" quick connect. Motor leads are separate and are 6" long.

OPERATION

To operate, turn knob counter clockwise to desired time interval. Internal contacts will transfer and remain transferred until pointer returns to zero and timer times out. At this point, contacts return to original position.

SPECIFICATIONS

Time Ranges

SYMBOL	Time Range
1	1 Min
2	5 Min
3	11 Min
4	30 Min
5	60 Min
7	11 Hr

Minimum Setting - 5% of Time Scale

Voltage/Frequency

115V (+10%, -15%) 60 Hz
230V (+10%, -15%) 60 Hz

Burden

2.2 Watts

Output Rating

15 Amp, 1/8 HP, 220 VAC
125 VAC, 250 VAC

Contact Arrangement

SPDT — Form "C"

Life — Mechanical and Electrical

10,000 Cycles

Operating Temperature

0°F to +140°F (-17°C to +60°C)

Laboratory Testing

U.L. Recognition E61735 

Eagle Signal Controls

A Division of Mark IV Industries, Inc.
8004 Cameron Road, Austin, Texas 78753 U.S.A.

TIME CONTROL



MOUNTING DIMENSIONS

XXX = INCHES
(XXX) = mm

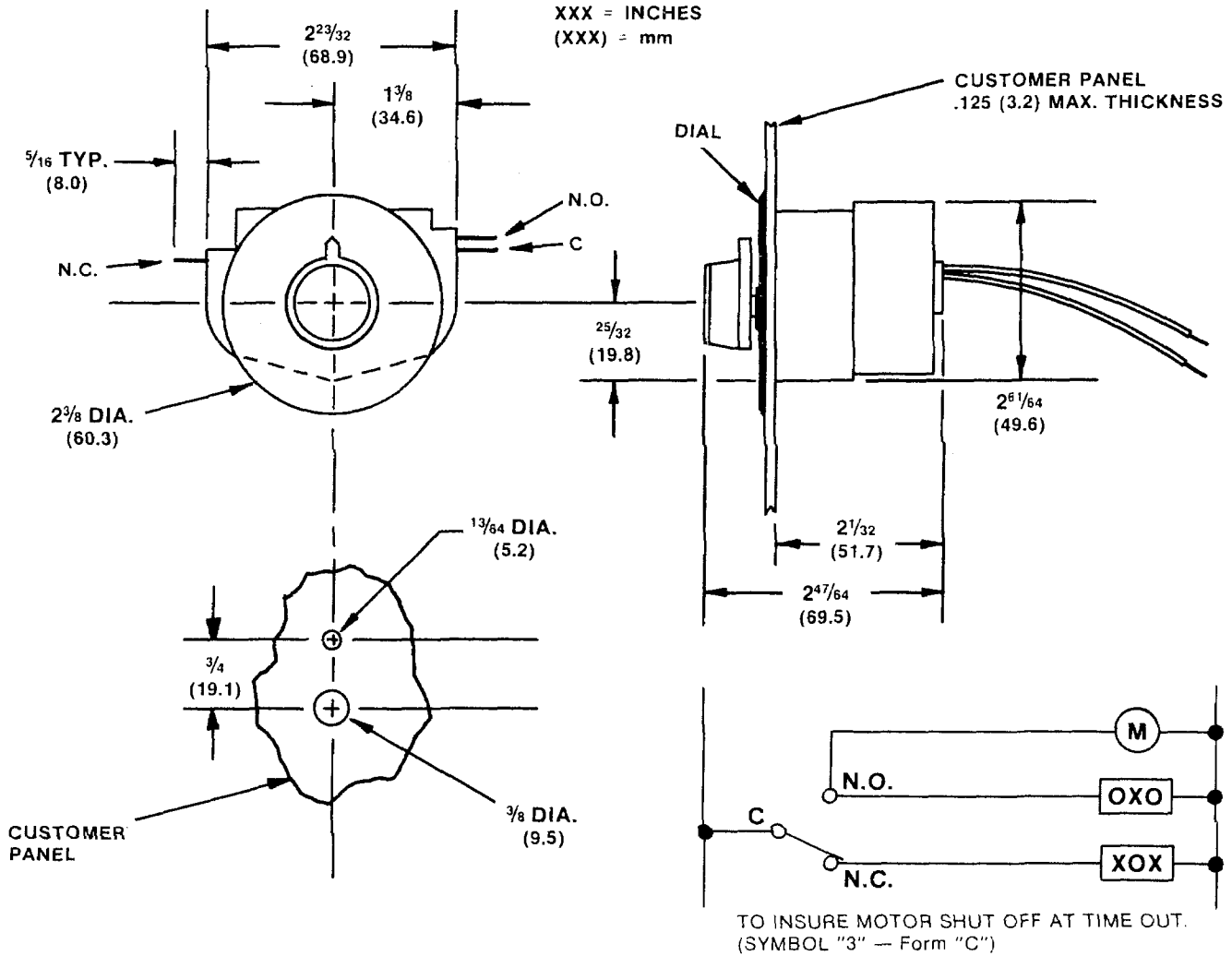

ORDERING INFORMATION

Consult Eagle for availability of other time ranges, voltages, and frequencies.

TIME RANGES

SYMBOL	Time Range
1	1 Min
2	5 Min
3	11 Min
4	30 Min
5	60 Min
7	11 Hr

TF 2 3 A6

VOLTAGE & FREQUENCY

SYMBOL	DESCRIPTION
A6	115V 60 Hz
B6	230V 60 Hz

SWITCH ARRANGEMENT

SYMBOL	DESCRIPTION
3	Form "C" SPDT