

BLM 700 Series MicroDrive Brushless DC Control



The BLM700 Series from Dart is the brushless DC version of the very popular Dart Micro-Drive Series of closed loop controls. The BLM700 Series continues this success by providing the OEM designer an integrated, fully programmable digital display with the latest technology brushless DC motor speed control. Even better, the BLM700 does not require a separate motor speed pickup, instead utilizing the existing motor hall-effect transistors to provide actual speed information to close the loop.

The BLM Series is available in a NEMA 4X 1/8 DIN panel mount. This microprocessor-based closed loop BLDC control maintains $\pm 1/2$ RPM of set speed by using a full velocity form PID algorithm. The BLM700 allows for user configuration of MIN, MAX, ACCEL, DECEL and display units that are all maintained in non-volatile on-board memory. The unit has a program lockout capability to prevent changes being made to the configuration except under managed conditions.

History Note-2000

Gladiator
wins Oscar
for
Best Movie

Dart
implements
Lean
Manufacturing
& ISO 9001

BLM700 SERIES STANDARD FEATURES

- Microprocessor-based design
- Digital closed-loop accuracy to $\pm 1/2$ RPM
- Non-volatile memory stores configuration
- Factory or field programmable via front-panel
- Configurable MIN, MAX, ACCEL, DECEL
- Configurable alarms / status and alarm indicators
- Program-enable jumper prevents tampering
- Source power 12 or 24-48 VDC (jumper selectable)
- Transient voltage protection
- Self-contained power supply for motor halls
- Large 4 digit, 1/2" LED display
- Durable NEMA 4X rated aluminum housing
- Forward or Reverse motor (jumper selectable)

SPECIFICATIONS

- Input voltage 12-48 VDC (jumper selectable)
- Continuous load current 8 Amps
- Overload current 150% for 30 seconds
- Adjustable Current Limit
- Jumper selectable motor hall spacing (60° or 120°)
- Motor hall sensor power supply provided (5V @ 50mA)
- Display type – 4 digit 1/2" LED
- Display range – 0 to 9999
- Programmable display – rate or time in process
- NEMA 4X panel mount enclosure
- Pluggable connector for external wiring

CONNECTION DIAGRAMS

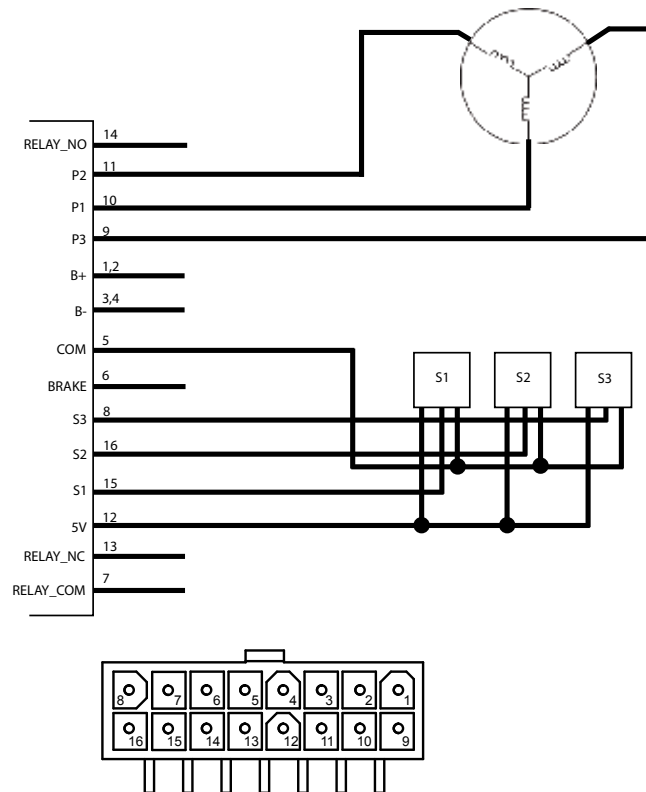

OPERATING CONDITIONS

Temperature..... -10° to +45° C.

BLM700 SERIES SELECTION GUIDE

BLM701P

** More versions coming soon! Check with Dart to discuss your application and for availability.

DIMENSIONAL SPECIFICATIONS

MODEL	WIDTH	HEIGHT	DEPTH
<i>BLM700 English (inches)</i>			
Housing	3.620	1.656	4.625
Lens	4.539	2.289	0.375
<i>BLM700 Metric (millimeters)</i>			
Housing	91.95	42.06	117.47
Lens	115.29	58.14	9.52

OPTIONS

Isolated 4-20mA input/output for desired/actual speed.
Factory or field installed..... OPT 420