



# AdaptaBeacon® Screw Base Beacons & Strobes

**Weatherproof**

## 110 Series



The Edwards 110 Series AdaptaBeacon flashing lights and strobes provide a bright visual indication to signal warning of temporary hazards. They install easily into a standard light socket and are suitable for indoor or outdoor temporary installation.

They are particularly effective in high noise level areas, where ear protection must be worn and audible signals may not be heard. They can advise personnel in manufacturing and industrial areas when an operation is starting or stopping or that they are entering a temporarily restricted area or an area of high danger.

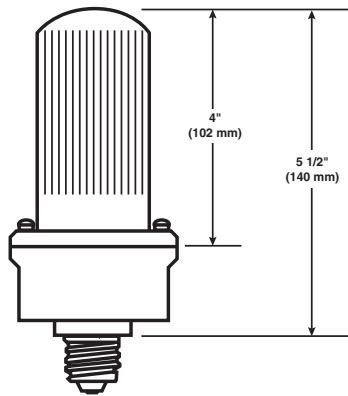

### FEATURES

- > Gasketed
- > Screw mount base
- > Available in strobe and flashing incandescent
- > Lenses available in five colors: amber, blue, clear, green and red

### AGENCY APPROVALS

- > CE Marked

Cat. No.	Description	Lens Color	Replacement Lens	Electrical Rating	Bulb Life	Replacement Light Source
110FINR-N5	Flashing Incandescent	Red	110-LR	120V 50/60 Hz 0.96 Amps	1,000 hr.	Industry Standard No. 15T7DC
110FINA-N5		Amber	110-LA			
110FINB-N5		Blue	110-LB			
110FING-N5		Green	110-LG			
110FINC-N5		Clear	110-LC			
110STR-N5	Strobe	Red	110-LR	120V 50/60 Hz 0.03 Amps	3,500 hr.	Replacement PC board assembly 110LS-ST-N5
110STA-N5		Amber	110-LA			
110STB-N5		Blue	110-LB			
110STG-N5		Green	110-LG			
110STC-N5		Clear	110-LC			

© Copyright 2004 Edwards



90 Fieldstone Court | Cheshire, CT 06410  
 Ph: 203.699.3300 | Fx: 203.699.3108  
[www.edwards-signals.com](http://www.edwards-signals.com)

D-04

**3-97**