



200 Class 36mm Stacklight™

The 200 Class 36mm Stacklight™ is a versatile signaling device that may contain up to six light modules or five light modules and one sounder module in a single, integrated stack. The lens modules are available with LED light sources, and in red, amber, green, blue, yellow and white. The 36mm is available as a Steady Burn LED device. The lenses are made from a self-extinguishing polycarbonate material and are scratch and impact resistant.

An optional piezoelectric sounder module complements the 36mm visual signals of the Stacklight™. The sound module has been designed so that it always sits in the top position of the Stacklight™.

The 200 Class 36mm Stacklight™ features an interlocking system for quick assembly without any tools. It is available in industrial gray or basic black and offers multiple voltage ranges to provide solutions for most industrial applications while also meeting machine builder and OEM requirements.



200 Class 36mm Stacklight™ Features

- cULus Listed
- IP65 without Sounder
- CE approved
- Six lens colors
- LED light source
- Steady Burn
- Available in Industrial Gray or Basic Black
- Stackable up to six total modules including sounder
- Quick and simple assembly with NO tools required
- Optional Piezoelectric Sounder (one single tone – 72dB)
- Available in 24VAC/DC
- Operating Temperature -22°F to 122°F (-30°C to 50°C)

200 Class 36mm Stacklight™

Description	Cat. No.*				
Wiring Base and Cover - Gray	236BC				
Module Type	Cat. No.*	LED Color	Operating Voltage**	Current	dB (A) 1m
200 Class 36mm Modules - Gray	236LEDSB24AD	Blue	24V AC/DC	0.050A	
	236LEDSA24AD	Amber	24V AC/DC	0.045A	
	236LEDSR24AD	Red	24V AC/DC	0.050A	
	236LEDSG24AD	Green	24V AC/DC	0.040A	
	236LEDSY24AD	Yellow	24V AC/DC	0.045A	
	236LEDSW24AD	White	24V AC/DC	0.050A	
Piezoelectric Acoustic - Gray	236PZO		24V AC/DC	0.010A	72

*NOTE: Add "B" to end of the catalog number for Basic Black unit.

**AC voltage frequency is 50/60 Hz

Accessories

Description	Cat. No.
Junction Box - Gray	270JBX*
Footring with Extension - Gray	270KIT*
Threaded Extension Pole 100mm - Gray	270TEP*
Threaded Footring - Gray	270THF*
Threaded Wall Mount - Gray	270TWM*
Double Threaded Wall Mount - Gray	270TWM2*
270 Flexible Steel Extension Stem - 370mm	270FLXT
270 Stainless Steel Extension Stem - 100mm	270SSXT100
270 Stainless Steel Extension Stem - 200mm	270SSXT200
270 Stainless Steel Extension Stem - 400mm	270SSXT400
270 Female Adapter Base - Gray	270FMLADAPT

*NOTE: Add "B" to end of the catalog number for Basic Black unit.



Junction Box



Threaded Footring



Footring with Extension



Threaded Extension Pole

Dimensional Drawings

Acoustic Module

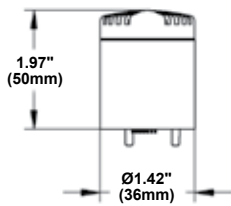

LED Module

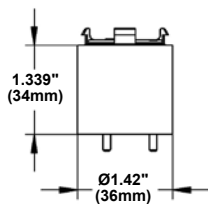

Base and Cover

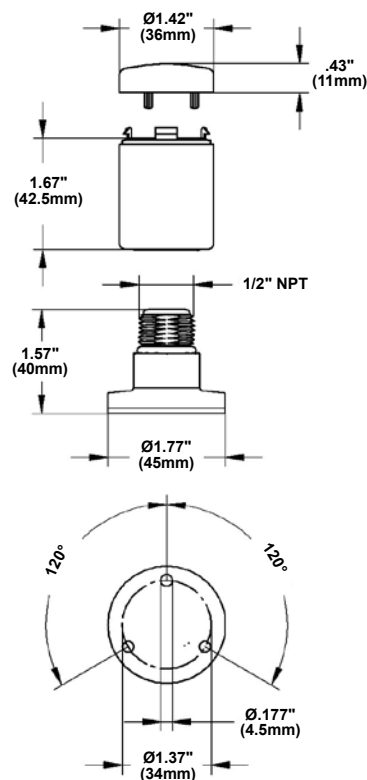

Threaded Wall Mount



Double Threaded Wall Mount

Agency Approvals



100mm

200mm

400mm

370mm

Stainless Steel
Extension Stem

Flexible Steel
Extension Stem



9 Farm Springs Road
Farmington, CT 06032
1.800.336.4206
www.edwardssignaling.com

© Copyright 2011 Edwards Signaling

Data Sheet ES001-0121 Issue 1
Not to be used for installation purposes.
Page 2 of 2