



AdaptaBeacon® Industrial Truck Strobe

Twist-On Lens, Multi-Voltage

3000SD-EK Series

FEATURES

- > 1.5 Joule Strobe
- > 12-48V DC
- > 80 Nominal Single Flashes per minute
- > Six lens colors: red, amber, blue, green, magenta and clear
- > Flange mount
- > 18" wire leads
- > Low current draw
- > 150,000 peak candlepower

The 3000SD-EK Series AdaptaBeacon visual signals are surface, flange mount strobes designed for industrial applications and for applications where warning on a moving vehicle such as a fork lift or tow motor is required.

The light flashes at 80 nominal single flashes per minute. The strobe is rated at 1.5 Joules. The unit draws exceptionally low current for a 12-48 V DC unit. The twist on-off lens makes for easy strobe tube and/or lens replacement. The 3000SD-EK also features a fully gasketed lens for environmental integrity.

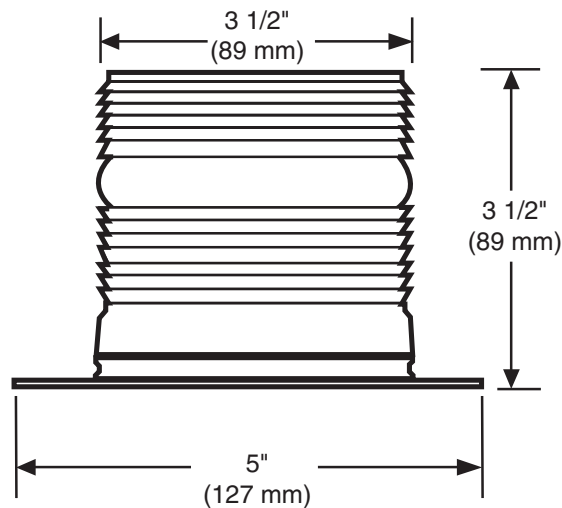

Cat. No.	Electrical Ratings			Lens Color	Replacement Lens	Replacement Strobe Tube
3000SDR-EK	12V DC	24V DC	48V DC	Red	3000SD-LR	91B-ST
3000SDA-EK	0.275 Amps	0.130 Amps	0.130 Amps	Amber	3000SD-LA	
3000SDB-EK				Blue	3000SD-LB	
3000SDG-EK				Green	3000SD-LG	
3000SDC-EK				Clear	3000SD-LC	

D-04