



AdaptaBeacon® Flashing Light with Horn

PLC Compatible

51 Series

FEATURES

- > Weatherproof
- > Internal, base mounted horn rated at 85 dB at 10 feet (3.05 m)
- > Cast base can be utilized as a junction box

AGENCY APPROVALS

- > AC models UL 1638 Listed
- > AC models cUL Listed

The Edwards 51 Series AdaptaBeacon flashing lights with horns are designed to provide a bright visual indication utilizing special optics within a shatter resistant polycarbonate lens. The polycarbonate double fresnel lens ensures efficient light dispersion. This is accomplished with a series of complementing fresnels that cause the dome to "fill" when the light is operating. Beam distance is also increased with fresnel lenses. Lenses are available in six colors: red, amber, blue, green, magenta, and clear. The unique base design allows horn audibility while maintaining the unit's weatherproof integrity.

Designed for indoor or outdoor installation. May be direct, 1/2" (13mm) conduit, or box mounted on a 4" (102mm) octagon box. For weatherproof installation, units must be mounted vertically with lens facing up. May be corner mounted indoors using the Cat. No. CBR, corner mount bracket, or wall mounted indoors using the Cat. No. WBR, wall mount bracket. For additional protection against breakage, use Cat. No. 92-GRD lens guard. See AdaptaBeacon Accessories, page 3-118.

Edwards flashing lights with horns can advise personnel in manufacturing, process and commercial areas when an operation is starting or stopping. Often used in airport baggage carousels. Usually used for signaling equipment malfunctions, security intrusions, or pinpointing problem locations. Can warn personnel that they are entering a restricted area or an area of high danger. May be used where a smaller light output is desired or where many multiple smaller flashing lights are specified.

D-04



TECHNICAL INFORMATION

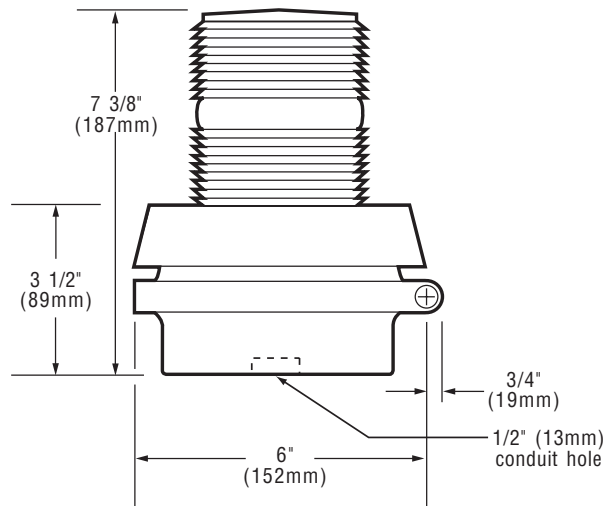

Cat. No.	Lens Color	Replacement Lens	Lamp Ratings	Replacement Flasher	Electrical Ratings	Replacement Lamp
51R-N5-40W	Red	92-LR	40 watts	P-041917-0026	120V 50/60 Hz	50LMP-40W
51A-N5-40W	Amber	92-LA	266 lumens*		0.29 Amps	(P-041695-0108)
51B-N5-40W	Blue	92-LB	3341 candlepower			
51G-N5-40W	Green	92-LG	3,920 hours			
51M-N5-40W	Magenta	92-LM				
51C-N5-40W	Clear	92-LC				
51R-E1	Red	92-LR	24 watts	P-041917-0028	12V DC	Industry Trade
51A-E1	Amber	92-LA	189 lumens*		1.0 Amps	No. 94
51B-E1	Blue	92-LB	2374 candlepower			
51G-E1	Green	92-LG	700 hours**			
51M-E1	Magenta	92-LM				
51C-E1	Clear	92-LC				
51R-G1	Red	92-LR	24 watts	P-041917-0028	24V DC	Industry Trade
51A-G1	Amber	92-LA	402 lumens*		1.1 Amps	No. 1638
51B-G1	Blue	92-LB	5049 candlepower			
51G-G1	Green	92-LG	3,180 hours**			
51M-G1	Magenta	92-LM				
51C-G1	Clear	92-LC				
51R-G5-20W	Red	92-LR	20 watts	P-041917-0029	24V 50/60 Hz	Industry Trade
51A-G5-20W	Amber	92-LA	402 lumens*		1.1 Amps	No. 1638
51B-G5-20W	Blue	92-LB	5049 candlepower			
51G-G5-20W	Green	92-LG	3,180 hours**			
51M-G5-20W	Magenta	92-LM				
51C-G5-20W	Clear	92-LC				

*Bulb manufacturer's lumen rating **Projected lamp life based on manufacturer's calculated long life at 65 FPM and 50% duty cycle.

SIGNAL INPUT LOAD CHARACTERISTICS*

Cat. No.	Operating Voltage	Max. off state leakage current (mA)	Continuous on Current (mA)	Surge (inrush/duration) Amps/milliseconds
51()-G1	24V DC	25	1100	3/100
51()-N5-40W	120V AC 60 Hz	25	350	2/8

*This device is PLC compatible and may be operated by PLCs with output characteristics that match the input load requirements of this signal.

© Copyright 2004 Edwards



90 Fieldstone Court | Cheshire, CT 06410
 Ph: 203.699.3300 | Fx: 203.699.3108
www.edwards-signals.com

D-04

3-17