

Description

The 301-BT Series 300 DPST safety interlock switch is designed for use with safety monitored relays or monitored circuits. To achieve the optimum Series 300 defeat resistant feature of the 301-BT, both the switch circuit (Circuit 1) and the tamper circuit (Circuit 2) must be connected. An optional third circuit can be provided to indicate at the panel which guard is open.

Notes:

1. Environmental: Pollution Degree II
2. Correct use of this control device is an essential part of proper machine cycle control.
3. Failure to follow ALL instructions could lead to serious bodily injury or death.
4. Maintenance to be done by qualified personnel only.
5. The connecting cables between the INT devices and the switches must be located in an IP 23 type enclosure (minimum).
6. The mounting for the switch and the actuator magnet must be accomplished per this specification.
7. Non-removable hardware must be used for installation.
8. The housing of the 300-BT must be connected to the PE (Primary Earth) ground circuit via a lock washer on the mounting screw. The PE ground symbol must be placed adjacent to the screw.

To verify switch operation with an ohmmeter:

Set range at 20 mega ohms (switches with triac output, set ohm range at 20 kilo ohms). For a normally open switch, the meter will read a high impedance with the actuator away. It will read high kilo ohm to infinity range) with the actuator within sense range. You will see the opposite reading for a normally closed switch.

Dimensions

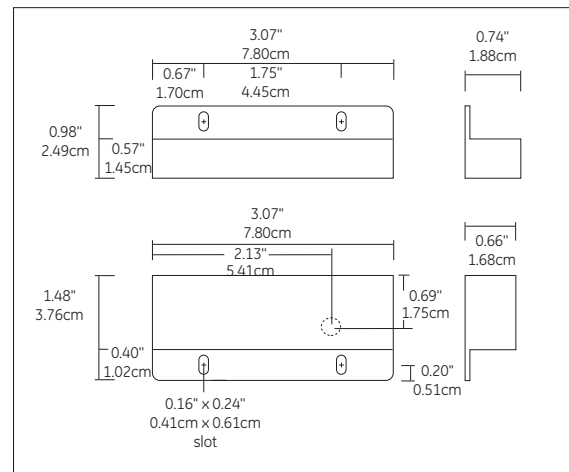

Safety Interlock Switch

300 Series

- | | |
|-----------------|----------------|
| 301-BT | 303-BT |
| 301-BT-SPNHJ6 | 303-BT-SPNHJ6 |
| 301-BT-SPNHJ12 | 303-BT-SPNHJ12 |
| 301-BT-SPNHJ15 | 303-BT-SPNHK12 |
| 301-BT-SPNHJ25 | |
| 301-B3T-SPNHJ12 | |
| 301-B3T-SPNHJ25 | |



Installation

Use non-removable screws, bolts or nuts to mount the switch and actuator. Do not over-torque mounting hardware.

1. Position the switch and actuator so the labels are reading in the same direction (See Figure 1).
2. Mount the switch on the stationary frame of the machine and mount the actuator on the moveable guard, door or gate. Keep the switch and actuator within the listed sense range. (See Ordering Information.) See Figure 2 for recommended mounting configurations.
3. Mounting on a ferrous material will effect the sense range a minimum of 50%. However, a 1/4" non-ferrous spacer positioned under the magnet and/or switch should restore most of the lost sense range.
4. For best protection against operator defeat, mount with non-removable screws, bolts or nuts. See Ordering Information for details.
5. **Caution!** When not used with a Sentrol INT relay, particular care must be taken to determine the actual load of the switch circuit. High voltage transients from coils, motors, contactors and solenoids must be considered. Transient protection, such as back-to-back zener diodes (TransZorb®) or an RC network, is recommended for such loads to ensure that maximum ratings of the switch are not exceeded. Not recommended to be used with tungsten filament loads because of high current inrush surges. Line capacitance and load capacitance must be considered. Excessive line capacitance can be caused by cable lengths over 50' when using a maximum 48 VAC. A resistor can be added in series to limit the inrush current (at least 48 ohms for 24 Volt applications).
 - The resistor can be added in series just before the load.
 - The voltage drop and the power rating of the resistor must be considered.

$$\text{Voltage drop} = I \cdot R$$

$$\text{Watts} = I^2 \cdot R$$

(I = maximum continuous current of the load)

6. When mounting the switch on an ungrounded machine, ground the switch housing by connecting your ground lead to one of the switch mounting screws.

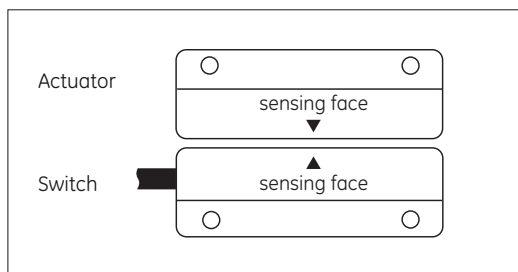

Figure 1

Mounting Configurations

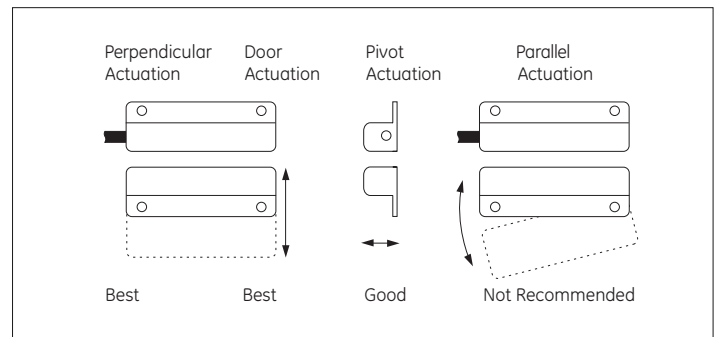
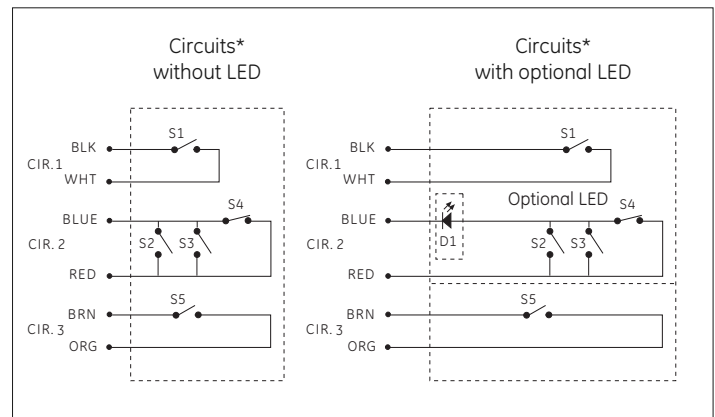

Figure 2

The parallel actuation can result in on/off/on signal if the actuator passes by the switch rather than coming to rest in proximity to it. This is NOT a recommended configuration for safety interlock applications.



*Circuits shown with magnet actuator away from switch.

- S1** Normally open reed switch, closed when actuator is within 0.6"
- S2, S3** Normally open reed switches, will close if misaligned or tampered with a standard magnet
- S4** Biased closed reed switch, open when actuator is between 0.3" and 0.6"

N.O. circuit: Black and white wires.

N.C. biased tamper circuit: Red and blue wires.

N.O. monitor circuit: Orange and brown wires.

Wiring Diagram for Category 3

Inputs shown with safety gates/guards in closed position.
One Series 300-BT GuardSwitch™ required for each safety gate.

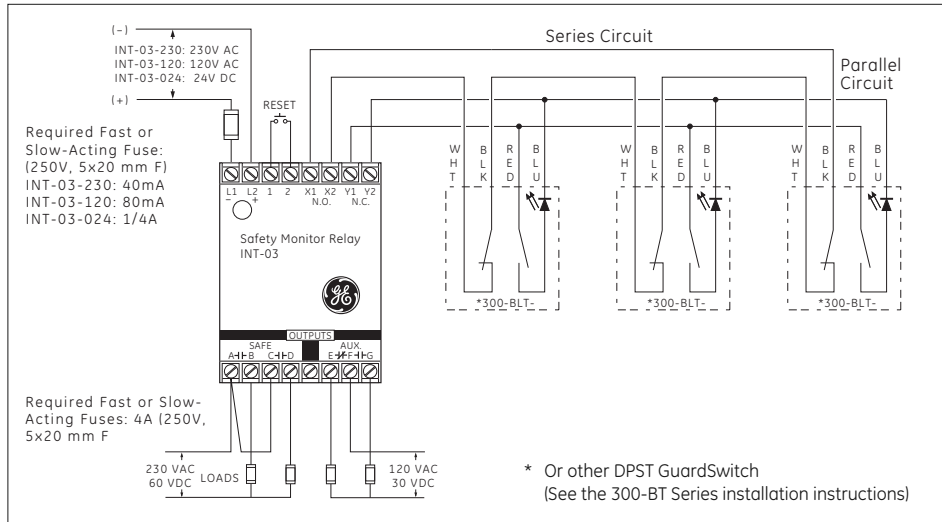

Note: The LED on the BLT model will be ON when the guard is open.

Fuses: 1A (250V)

Multiple DPST GuardSwitches: Show with actuators in position, all guards closed. The LED of the BLT model will be on when the guard is open. If multiple guards are open, LED will be dimmer. The maximum number of GuardSwitches that can be used is 50, although troubleshooting and line resistance must be considered. (Do not exceed 30 Ohms of combined contact and line resistance. Each GuardSwitch will have less than 0.5 Ohms of resistance.)

Wiring Diagram for Category 4

Inputs shown with safety gate/guard in closed position.
Two Series 300-BT GuardSwitches™ with one INT relay are required for each safety gate.

When first applying the INT Safety Monitor Relay, the inputs must be cycled to check for proper operation before the output contacts close. To cycle the inputs, the guard must be opened and closed. This start-up test is sufficient; however we recommend that the proper operation of the switches and relay be checked at least every 24 hours.

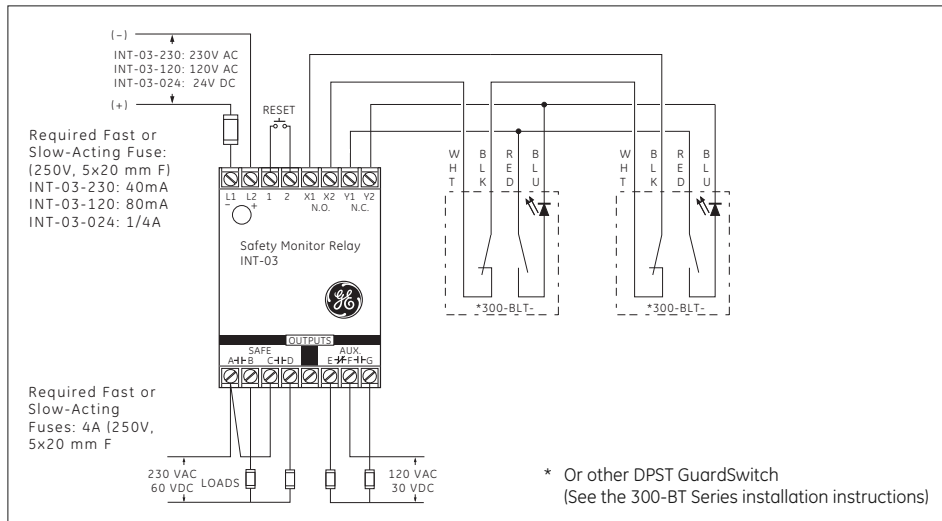

Note: The LED on the BLT model will be ON when the guard is open.

Fuses: 1A (250V)

General Specifications

Enclosure	304 Folded Stainless Steel
Temperature Range	-40°F to 180°F (-40°C to 80°C)
Environmental	Hermetically Sealed Contact Switch Encapsulated in Polyurethane
NEMA Rating	1, 2, 4, 4X, 5, 12, 12K
Protection Class	IP 66
Response Time	1 msec (5.4VA); 10 msec (150VA)
Individual Circuits	The two circuits do not switch simultaneously, and depend on the speed of the guard closure. Based on closure speed of 1' per second and a gap of 1/8", a delay of less than 50 msec is typical.
Life Cycles	100,000 Under Full Load; Up to 200,000,000 Under Dry Circuit
Lead Types/O.D.	18/4 SJTOW (K)/0.34" (0.86cm) 22/4 PVC Jacketed (J)/0.19" (0.48cm) 22/6 PVC Jacketed (J)/0.21" (0.53cm)

U.S.
T 888-378-2329
F 866-503-3996

Canada
T 519 376 2430
F 519 376 7258

Asia
T 852 2907 8108
F 852 2142 5063

Australia
T 61 3 9259 4700
F 61 3 9259 4799

Europe
T 32 2 725 11 20
F 32 2 721 86 13

Latin America
T 305 593 4301
F 305 593 4300

www.gesecurity.com/industrial

©2008 General Electric Company
All Rights Reserved

Electrical Specifications

Applies to all models

Circuit Number	Circuit Type	Contact Configuration	Load Rating	Switching Voltage	Switching Current
1	Switch: S1	N.O.	40W/VA	48VAC/VDC	1.0ADC 0.7AAC
2	Tamper: S2, S3, S4	N.C.	3W/VA	48VAC/VDC	.25A
2	w/optional LED: D1	N.C.	0.1-1.4W	48VDC (3V drop)	30mA
3	Monitor: S5	N.O.	10W/VA	48VAC/VDC	0.3ADC 0.3AAC

Ordering Information

Part Number	Contact Configuration	Sense Range Maximum	Break Range	Lead Length Nominal
301-BT-SPNHJ6	DPST: 1 N.O., 1 N.C.	0.6" (1.5cm)	1.2" (3.0cm)	6' (1.8m)
303-BT-SPNHJ6	DPST: 1 N.O., 1 N.C.	0.6" (1.5cm)	1.2" (3.0cm)	6' (1.8m)
301-BT-SPNHJ12	DPST: 1 N.O., 1 N.C.	0.6" (1.5cm)	1.2" (3.0cm)	12' (3.6m)
303-BT-SPNHJ12	DPST: 1 N.O., 1 N.C.	0.6" (1.5cm)	1.2" (3.0cm)	12' (3.6m)
303-BT-SPNHK12	DPST: 1 N.O., 1 N.C.	0.6" (1.5cm)	1.2" (3.0cm)	12' (3.6m)
301-BT-SPNHJ15	DPST: 1 N.O., 1 N.C.	0.6" (1.5cm)	1.2" (3.0cm)	15' (6.1m)
301-BT-SPHNJ25	DPST: 1 N.O., 1 N.C.	0.6" (1.5cm)	1.2" (3.0cm)	25' (7.5m)
301-B3T-SPNHJ12	TPST: 2 N.O., 1 N.C.	0.6" (1.5cm)	1.2" (3.0cm)	12' (3.6m)
301-B3T-SPNHJ25	TPST: 2 N.O., 1 N.C.	0.6" (1.5cm)	1.2" (3.0cm)	25' (7.5m)

Accessories

Part Number	Tamper Proof Screws and Screwdriver
1953	#6 x 3/4"L Tampruf Roundhead Screw
1954	#8 x 1-1/2"L Tampruf Roundhead Screw
1955	Tampruf Screwdriver
1956	Tampruf 1/4" Drive Bit for #6 and #8 Screws

Warning - Each electrical rating is an individual maximum and cannot be exceeded!

- The part numbers 301 and 303 are the same in all respects except the cable exits, 301 left and 303 right. Not all models are available in 303.
- Configuration with actuator away from the switch.
- Proximity of ferrous materials usually reduces sense range- typically by 50%. The shape and type of material cause a wide diversity of effects. Testing is required to determine actual sense range for specific applications.