



ELECTRIC CHARACTERISTICS

Nominal voltage	0/750 V _{AC} - 50/60 Hz
Phase to phase test voltage	3100 V _{DC} (2 s)
Phase to ground test voltage	3500 V _{DC} (2 s)
Climatic class	- 40 / +85 °C

RoHS

FIN1200HV	Rated Current 40°C (50°C)	ΣCx (μF) $\pm 5\%$	Cy1 (nF) $\pm 5\%$	Cy2 (nF) $\pm 5\%$	L1 (mH) $\pm 10\%$	Power Loss (W)
.016.V	18 (16)	60	100	100	2	14
.030.V	34 (30)	60	100	100	2	11
.050.V	55 (50)	60	100	100	2	10
.080.V	85 (80)	60	100	100	1.8	35
.100.V	110 (100)	60	100	100	1.5	42
.150.V	160 (150)	60	100	100	1.3	74
.200.V	210 (200)	60	100	100	0.9	90
.250.V	272 (250)	60	100	100	0.7	90
.280.V	290 (280)	60	100	100	0.7	80
.280.B	297 (280)	60	100	100	0.7	78
.320.B	330 (320)	60	100	100	0.7	80
.360.B	390 (360)	60	100	100	0.6	105
.400.B	435 (400)	60	100	100	0.6	110
.500.B	545 (500)	60	100	100	0.55	102
.600.B	654 (600)	60	100	100	0.55	108
.750.B	800 (750)	60	100	100	0.5	96
.900.B	940 (900)	60	100	100	0.5	80
.1000.B	1050 (1000)	60	100	100	0.45	115
.1250.B	1290 (1250)	60	100	100	0.45	101
.1500.B	1550 (1500)	60	100	100	0.4	120
.1600.B	1650 (1600)	60	100	100	0.4	130
.1750.B	1800 (1750)	60	100	100	0.4	135
.2000.B	2040 (2000)	60	100	100	0.38	138
.2250.B	2290 (2250)	60	100	100	0.38	145
.2500.B	2535 (2500)	60	100	100	0.38	170

ELECTRIC DIAGRAM

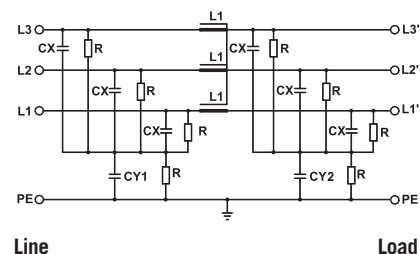

TYPICAL ATTENUATION

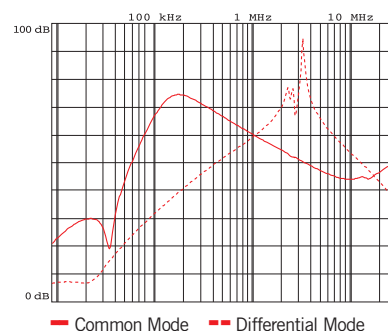

Total leakage current at 230 V phase to ground 50 Hz / 40°C

Nominal <3mA
Worst condition <10mA

Vertical bus-bar connections available upon request

MECHANICAL DIMENSIONS (mm)

FIN1200HHV	A	B	C	d2	d3	V	F	H	I	L	N	P	S	Weight Kg	Case
.016.V	90	100	46	-	-	28	4.5	246	220	235	35	70	64	3	1
.030.V	90	100	46	-	-	28	4.5	246	220	235	35	70	64	3	1
.050.V	90	100	46	-	-	28	4.5	246	220	235	35	70	64	3	2
.080.V	90	185	84	-	-	25	6.5	356	320	340	77.5	70	69	5	3
.100.V	90	185	84	-	-	25	6.5	356	320	340	77.5	70	69	5	3
.150.V	90	220	120	-	-	29	6.5	356	320	340	95	70	60	7	4
.200.V	90	220	120	-	-	29	6.5	356	320	340	95	70	60	7	4
.250.V	90	220	120	-	-	30	6.5	356	320	340	95	70	60	9	5
.280.V	90	220	120	-	-	30	6.5	356	320	340	95	70	60	9	5
.280.B	90	220	120	6	20	42	6.5	356	320	340	95	70	55	9	6
.320.B	90	220	120	6	20	42	6.5	356	320	340	95	70	55	9	6
.360.B	130	230	150	10	25	42	6.5	420	380	400	100	100	85	13.5	7
.400.B	130	230	150	10	25	42	6.5	420	380	400	100	100	85	13.5	7
.500.B	130	230	150	15	30	48	6.5	510	450	480	100	100	85	19	8
.600.B	130	230	150	15	30	48	6.5	510	450	480	100	100	85	19	8
.750.B	160	250	140	20	40	94	8.5	510	450	480	100	110	110	27	9
.900.B	160	250	140	20	40	94	8.5	510	450	480	100	110	110	27	9
.1000.B	180	350	200	20	60	97	8.5	610	550	580	150	130	117	32	11
.1250.B	180	350	200	20	60	97	8.5	610	550	580	150	130	117	32	11
.1500.B	180	350	200	20	60	97	8.5	610	550	580	150	130	117	32	11
.1600.B	180	350	200	20	60	97	8.5	610	550	580	150	130	117	32	11
.1750.B	180	350	200	20	60	97	8.5	610	550	580	150	130	117	32	11
.2000.B	180	350	200	20	60	97	8.5	610	550	580	150	130	117	32	11
.2250.B	180	350	200	20	60	97	8.5	610	550	580	150	130	117	32	11
.2500.B	180	350	200	20	60	97	8.5	610	550	580	150	130	117	32	11

CONNECTION

d (mm)	Line Torque (Nm)	d1(mm)	Ground Torque (Nm)
M5	4	M5	4
M5	4	M5	4
M6	6	M5	4
M8	14	M8	14
M8	14	M8	14
M10	18	M10	18
M10	18	M10	18
M12	20	M10	18
M12	20	M10	18
M8	14	M10	18
M8	14	M10	18
M8	14	M10	18
M8	14	M10	18
M10	25	M10	18
M10	25	M10	18
M12	50	M12	20
13.5	50	M12	20
13.5	50	M12	20
14	65	M12	20
14	65	M12	20
14	65	M12	20
14	65	M12	20
14	65	M12	20
14	65	M12	20

CASE 1/2/3

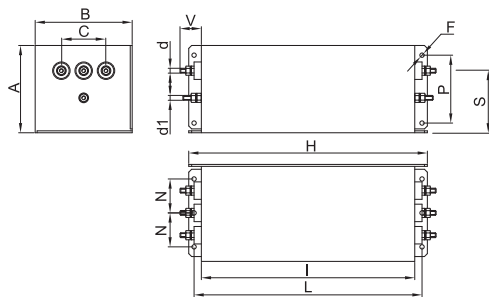

CASE 4/5

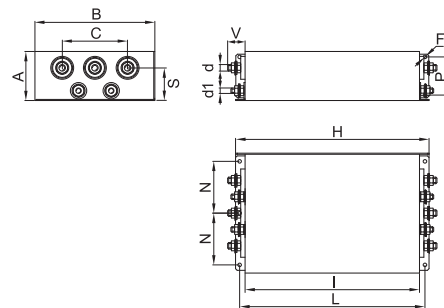

CASE 6/7/8/9/10/11

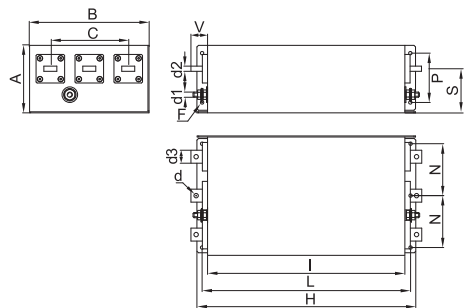

Vertical bus-bar connections available upon request