



ELECTRIC CHARACTERISTICS

Nominal voltage	0/1000 V _{DC} - 0/700 V _{AC} - 50/60 Hz
Phase to phase test voltage	3100 V _{DC} (2 s)
Phase to ground test voltage	3400 V _{DC} (2 s)
Climatic class	- 40 / +85 °C

RoHS

UL1283
CSA C22.2
E215863

FIN1220	Rated Current 40°C (50°C)	Σ Cx (μF) ± 5%	Cy1 (nF) ± 5%	Cy2 (nF) ± 10%	L1 (mH) ± 10%	Power Loss (W)
.005.V	7 (5)	8.8	100	100	7	5
.010.V	12 (10)	8.8	100	100	5	7
.016.V	18 (16)	40	100	100	2	14
.030.V	34 (30)	40	100	100	2	11
.050.V	55 (50)	40	100	100	2	10
.080.V	85 (80)	40	100	100	1.8	39
.100.V	110 (100)	40	100	100	1.5	45
.130.V	134 (130)	40	100	100	1.3	49
.150.V	160 (150)	40	100	100	1.3	69
.180.V	185 (180)	40	100	100	0.9	77
.200.V	210 (200)	40	100	100	0.9	85
.250.V	272 (250)	40	100	100	0.7	87
.280.V	297 (280)	40	100	100	0.7	77
.280.B	330 (320)	40	100	100	0.7	76
.320.B	330 (320)	40	100	100	0.7	77
.360.B	390 (360)	40	100	100	0.6	98
.400.B	435 (400)	40	100	100	0.6	102
.500.B	545 (500)	40	100	100	0.55	96
.600.B	654 (600)	40	100	100	0.55	102
.750.B	800 (750)	40	100	100	0.5	88
.900.B	940 (900)	40	100	100	0.5	72
.1000.B	1050 (1000)	40	100	100	0.45	102
.1250.B	1290 (1250)	40	100	100	0.45	96
.1500.B	1550 (1500)	40	100	100	0.4	108
.1600.B	1650 (1600)	40	100	100	0.4	115
.1750.B	1800 (1750)	40	100	100	0.4	120
.2000.B	2040 (2000)	40	100	100	0.38	122
.2250.B	2290 (2250)	40	100	100	0.38	127
.2500.B	2535 (2500)	40	100	100	0.38	140
.3000.B	3050 (3000)	40	100	100	0.38	150

ELECTRIC DIAGRAM

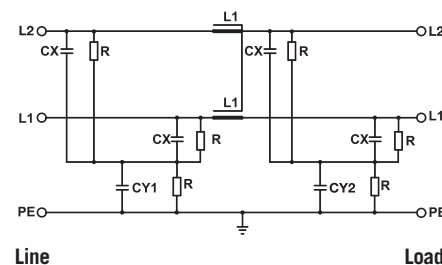

TYPICAL ATTENUATION

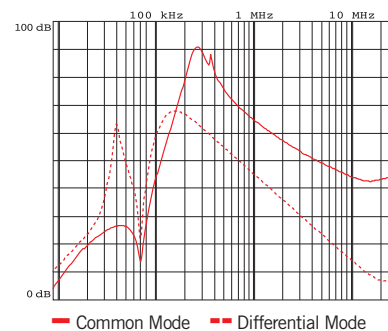

— Common Mode - - - Differential Mode

Total leakage current at 230 V phase to ground 50 Hz / 40°C

Nominal <3mA
Worst condition <10mA

Vertical bus-bar connections available upon request

MECHANICAL DIMENSIONS (mm)

FIN1220	A	B	C	d2	d3	V	F	H	I	L	N	N1	P	S	Weight Kg	Case
.005.V	58	86	44	-	-	14	4.5	186	160	176	30	-	40	38	2	1
.010.V	58	86	44	-	-	14	4.5	186	160	176	30	-	40	38	2	1
.016.V	90	100	46	-	-	28	4.5	246	220	235	35	-	70	64	3	2
.030.V	90	100	46	-	-	28	4.5	246	220	235	35	-	70	64	3	2
.050.V	90	100	46	-	-	28	4.5	246	220	235	35	-	70	64	3	3
.080.V/.100.V	90	100	40	-	-	28	4.5	246	220	235	35	-	70	69	3	4
.130.V/.150.V	90	185	120	-	-	29	6.5	356	320	340	77.5	-	70	60	5	5
.180.V	90	185	120	-	-	29	6.5	356	320	340	77.5	-	70	60	5	5
.200.V	90	185	120	-	-	29	6.5	356	320	340	77.5	-	70	60	5	5
.250.V/.280.V	90	220	120	-	-	30	6.5	356	320	340	95	-	70	60	7.5	6
.280.B/.320.B	90	220	120	6	20	42	6.5	356	320	340	50	190	70	55	7.5	7
.360.B	130	230	150	10	25	42	6.5	420	380	400	70	200	85	85	10	8
.400.B	130	230	150	10	25	42	6.5	420	380	400	70	200	85	85	10	8
.500.B	130	230	150	10	25	42	6.5	420	380	400	70	200	85	85	10	8
.600.B/.750.B	130	230	150	15	30	48	6.5	510	450	480	70	200	100	85	15.5	9
.900.B	160	250	140	20	40	94	8.5	510	450	480	70	200	110	110	23	10
.1000.B	160	250	140	20	40	94	8.5	510	450	480	70	200	110	110	23	10
.1250.B	160	250	140	20	40	94	8.5	510	450	480	70	200	110	110	23	10
.1500.B	180	300	200	20	60	97	8.5	560	500	530	80	250	130	117	27	11
.1600.B	180	300	200	20	60	97	8.5	560	500	530	80	250	130	117	27	11
.1750.B	180	300	200	20	60	97	8.5	560	500	530	80	250	130	117	27	11
.2000.B	225	350	200	25	80	100	8.5	610	550	580	150	-	-	112.5	45	12
.2250.B	225	350	200	25	80	100	8.5	610	550	580	150	-	-	112.5	45	12
.2500.B	225	350	200	25	80	100	8.5	610	550	580	150	-	-	112.5	45	12
.3000.B	225	350	200	25	80	100	8.5	610	550	580	150	-	-	112.5	45	12

CONNECTION

d (mm)	Line Torque (Nm)	Ground d1(mm)	Ground Torque (Nm)
M4	1.2	M4	1.2
M4	1.2	M4	1.2
M5	4	M5	4
M5	4	M5	4
M6	6	M5	4
M8	14	M8	14
M10	18	M10	18
M10	18	M10	18
M10	18	M10	18
M12	20	M10	18
M8	14	M10	18
M8	14	M10	18
M8	14	M10	18
M10	25	M10	18
M12	50	M12	20
M12	50	M12	20
M12	50	M12	20
M12	50	M12	20
M12	50	M12	20
M12	50	M12	20
M12	50	M12	20
M12	50	M12	20
M12	50	M12	20
M12	50	M12	20
M12	50	M12	20
M12	50	M12	20
M12	50	M12	20
M12	50	M12	20

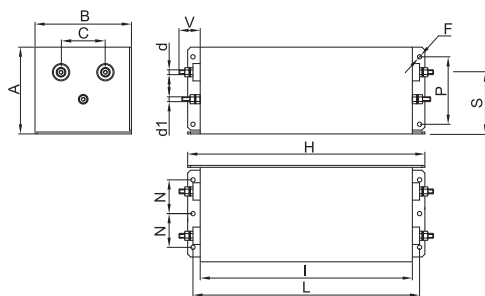
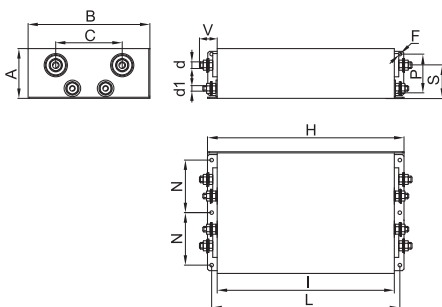
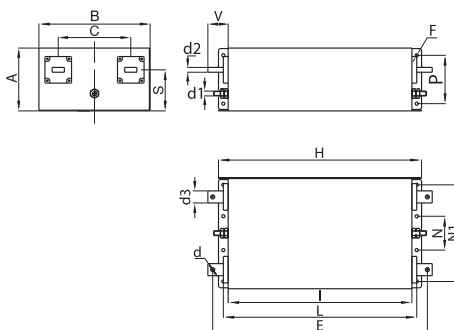
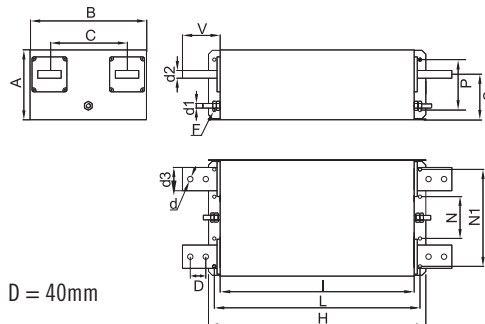
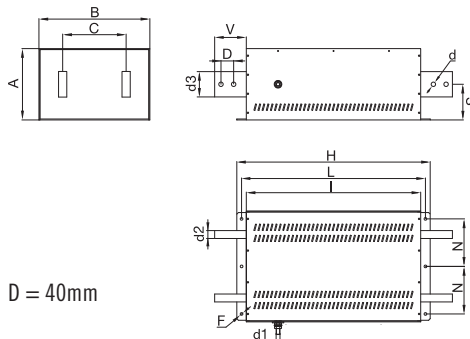
CASE 1/2/3/4

CASE 5/6

CASE 7/8/9

CASE 10/11

CASE 12

Vertical bus-bar connections available upon request