



FEDERAL SIGNAL

Safety and Security Systems / **Industrial**

Advancing security and well being

Model 191XL Series Beacon for Use in Hazardous Conditions



Installation and Maintenance Manual

2561421G
REV. G 912
Printed in U.S.A.



Warranty – Seller warrants all goods for five years on parts and 2-1/2 years on labor, under the following conditions and exceptions: Seller warrants that all goods of Seller's manufacture will conform to any descriptions thereof for specifications which are expressly made a part of this sales contract and at the time of sale by Seller such goods shall be commercially free from defects in material or workmanship. Seller reserves the right at the Seller's discretion to "Repair and Return" or "Replace" any item deemed defective during the warranty period. This warranty does not cover travel expenses, the cost of specialized equipment for gaining access to the product, or labor charges for removal and reinstallation of the product. This warranty shall be ineffective and shall not apply to goods that have been subjected to misuse, neglect, accident, damage, improper maintenance, or to goods altered or repaired by anyone other than Seller or its authorized representative, or if five years have elapsed from the date of shipment of the goods by Seller with the following exceptions: lamps and strobe tubes are not covered under this warranty. Outdoor warning sirens and controllers manufactured by Federal Warning Systems are warranted for two years on parts and one year on labor. No agent, employee, representative or distributor of Seller has any authority to bind the Seller to any representation, affirmation, or warranty concerning the goods and any such representation, affirmation or warranty shall not be deemed to have become a part of the basics of the sales contract and shall be unenforceable. THE FOREGOING WARRANTIES ARE EXCLUSIVE AND IN LIEU OF ALL OTHER WARRANTIES OR MERCHANTABILITY, FITNESS FOR PURPOSE AND OF ANY OTHER TYPE, WHETHER EXPRESS OR IMPLIED. These warranties shall not apply unless Seller shall be given reasonable opportunity to investigate all claims for allegedly defective goods. Upon Seller's instruction a sample only of allegedly defective goods shall be returned to Seller for its inspection and approval. The basis of all claims for alleged defects in the goods not discoverable upon reasonable inspection thereof pursuant to paragraph 8 hereof must be fully explained in writing and received by Seller within thirty days after Buyer learns of the defect or such claim shall be deemed waived.



Industrial Systems
2645 Federal Signal Drive • University Park, IL 60484-3167
Tel: 1-877-289-3246 • Fax: 708-534-4852
www.federal-signal-indust.com • www.fs-isys.com

Contents

Safety Messages to Installers	5
An Overview of the 191XL Series.....	6
Unpacking the Beacon.....	7
Pipe-Mounting the Beacon (191XL)	8
Surface-Mounting the Beacon (191XL-S).....	10
Wiring the Beacon	11
Wiring 120-240, 277 Vac Models.....	12
Wiring 24 Vac/dc Models.....	12
Safety Message to Maintenance Personnel	12
Changing from Flash Mode to Steady Mode.....	13
Cleaning the Fixture	16
Lubricating the Threaded Joint.....	17
Getting Service, Assistance, and Parts.....	17
Returning the Product for Credit	18

Tables

Table 1 Electrical ratings 7
Table 2 Installation Environment Ratings..... 7
Table 3 Ambient and Operating Temperature Range..... 8
Table 4 Replacement parts 17

Figures

Figure 1 Pipe-mounted beacon 9
Figure 2 Surface-mounted beacon 10
Figure 3 PCB removed from housing 15
Figure 4 Location of jumper J3 on PCB..... 16

Safety Messages to Installers

⚠ WARNING

It is important to follow all instructions shipped with this product. This device is to be installed by a trained electrician who is thoroughly familiar with the National Electrical Code and/or Canadian Electrical Code and will follow the NEC and/or CEC Guidelines as well as all local codes. This beacon should be considered a part of the warning system and not the entire warning system.

The selection of the mounting location for the beacon, its controls and the routing of the wiring are to be accomplished under the direction of the facilities engineer and the safety engineer. In addition, listed below are some other important safety instructions and precautions you should follow:

- Read and understand all instructions before installing or operating this beacon.
- Do not connect this beacon to the system when power is on.
- Do not disconnect the beacon while circuit is live or unless the area is known to be free of ignitable concentrations. Keep the beacon tightly closed when in operation.
- After installation, make sure that all set screws and threaded joints are properly tightened.
- Never alter the unit in any manner. Safety in hazardous locations may be endangered if additional openings or other alterations are made in units specifically designed for use in these locations.
- To be an effective warning device, this product produces bright beacon that can be hazardous to your eyesight when viewed at a close range. Do not stare directly into this lighting product at a close range or permanent damage to your eyesight may occur.

Installation and Service Instructions

- After installation, test the beacon to make sure that it is operating properly.
- Keep the unit tightly closed when in operation.
- After testing is complete; provide a copy of this instruction booklet to all personnel.
- Establish a procedure to routinely check the beacon for proper activation and operation.

Failure to follow all safety precautions and instructions may result in property damage, serious injury, or death.

An Overview of the 191XL Series

This equipment is suitable for use in Class I, Division 2, Groups A, B, C and D; Class II, Division 1, Groups E, F & G; Class III OR non-hazardous locations only.

This strobe light can be mounted to a Federal Signal Model LHWB bracket. If installed in this way, the entire assembled device is suitable only for Class I, Div. 2, Groups A, B, C, and D; Class II, Div. 2, Groups F and G; Class III locations.

The Model 191XL LED Beacon is a UL listed visual signal for operation in harsh environments and hazardous locations and has been investigated by UL as meeting Type 4X and IP66 enclosure requirements. The unit is rated for operation on 100Vac to 265 Vac, 50/60 Hz, 0.21 A, 277 Vac, 50/60 Hz, 0.13A, or 24 Vdc/ac 50/60 Hz, 0.38 A. The 191XL can be supplied with colors of red, amber, green, blue, and clear. The 191XL is factory-set to operate 60 flashes/minute. There is an option to operate the LED Beacon in Steady Mode. (See “Changing from Flash Mode to Steady Mode” on page 13). Models are available for pipe mounting (191XL) or surface mounting (191XL-S).

These devices are intended for permanent installation and operation in accordance with Title 46, Code of Federal Regulations, Parts 110–113, or Title 33, Code of Federal Regulations, Part 183, Sub-part I, Section 183.410, and the

applicable requirements of the American Boat and Yacht Council, Inc., and/or ANSI/NFPA 302, “Fire Protection Standard for Pleasure and Commercial Motor Craft.”

Unpacking the Beacon

⚠ WARNING

EXPLOSION HAZARD—Damaged domes can lead to explosions that could result in serious injury or death.

After unpacking the beacon, examine it for damage that may have occurred in transit. If the beacon has been damaged, do not attempt to install or operate it. File a claim immediately with the carrier, stating the extent of the damage. Carefully check all envelopes, shipping labels, and tags before removing or discarding them. Disposal of all shipping materials must be carried out in accordance with national and local codes and standards. If any parts are missing, please call Federal Signal Customer Support at 708-534-4756.

Table 1 Electrical ratings

Operating Voltage:	24 Vdc/ac	100–265, 277 Vac	277 Vac
Flashes/Minute:	60 FPM	60 FPM	60 FPM
Maximum Operating Current:	380 mA	210 mA	130 mA
Frequency:	DC/50/60	50/60	50/60
DC In-Rush Current:	1.75 A at 24 Vdc for 5 ms.		
AC In-Rush Current:	2.0 A at 85 Vac and 1.5 A at 265 and 277 Vac for 0.25 ms.		

Table 2 Installation Environment Ratings

Ambient Storage Rating: –55 °C to +70 °C
Ambient Operating Rating: –50 °C to +66 °C
Type 4X (water-tight and corrosion resistant) and indoor/outdoor use
IP66 (dust-tight and protection against heavy seas) and outside type (saltwater)

Table 3 Ambient and Operating Temperature Range

	Temperature Code or Maximum Temperature, °C								
	40 °C Ambient			55 °C Ambient			66 °C Ambient		
Hazardous Locations	24 V	100–265 Vac	277 Vac	24 V	100–265 Vac	277 Vac	24 V	100–265 Vac	277 Vac
Class I, Div 2, Groups A, B, C, and D	T6	T6	T5	T5	T5	T5	T4A	T4A	T5
Class II, Div 1, Groups E, F, and G	T6	T6	T6	T6	T6	T6	T6	T6	T6
Class III	T6	T6	T6	T6	T6	T6	T6	T6	T6

Pipe-Mounting the Beacon (191XL)

⚠ WARNING

EXPLOSION HAZARD—*To reduce the risk of fire or explosion, do not install the beacon in a hazardous location if the operating temperature exceeds the hazardous atmosphere’s ignition temperature. Before proceeding, consult the product nameplate and determine the operating temperature of the beacon.*

NOTE: To comply with NEC Section 300-14, which requires a minimum of 6 inches (15.25 cm) of free conductor at a junction, when mounting the Model 191XL, the mounting pipe used to join the unit to a splice box should be no longer than 10 inches (25.4 cm).

The Model 191XL has provisions for mounting a 3/4" pipe and can be mounted in any position.

1. Before mounting the beacon, ensure that the mating threads are clean.
2. To prevent the ingress of water and dust, apply conductive sealant to the conduit threads prior to mounting. If non-conductive sealant is used, the enclosure must be earthed via the provided internal grounding wire/grounding screw to ensure proper grounding continuity.

3. In high-humidity environments when units are mounted dome down, condensation may occur in the conduit system. Use properly rated conduit seals/drains to prevent moisture from entering the fixture.

IMPORTANT: To prevent the connection from loosening, tighten the fixture to a MINIMUM torque of 5 ft-lb (6.8 N·m) after threading it onto the pipe.

4. Thread the fixture onto the 3/4" pipe and secure it with the set screw.

Figure 1 Pipe-mounted beacon

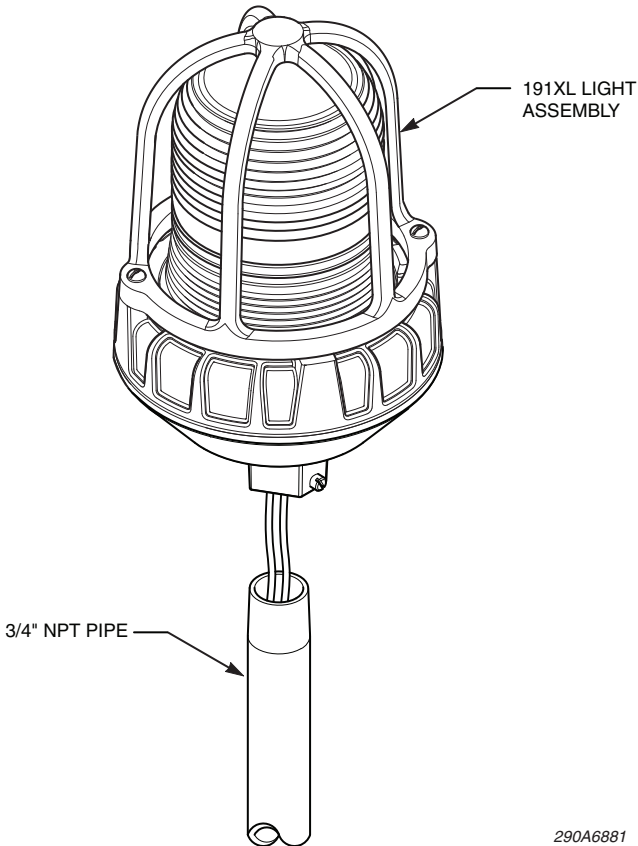

290A6881

Surface-Mounting the Beacon (191XL-S)

To surface mount the beacon:

1. Use the mounting base as a template to mark the location of the two mounting holes.
2. Drill a 9/32 inch (7.143 mm) hole at each mark.
3. Secure the beacon to the mounting surface with installer supplied hardware.

Figure 2 Surface-mounted beacon

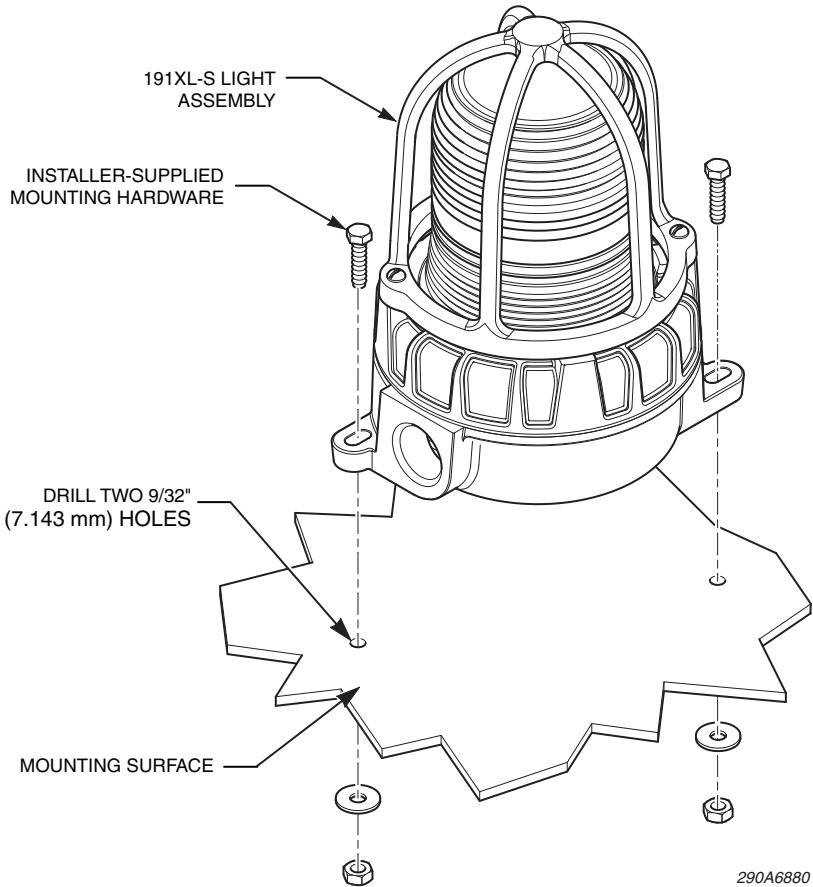

290A6880

Wiring the Beacon

⚠ WARNING

SHOCK HAZARD

To avoid electrical shock hazards, do not connect wires while power is applied.

⚠ WARNING

EXPLOSION HAZARD

Do not disconnect the beacon while the circuit is live or unless the area is known to be free of ignitable concentrations. Keep the beacon tightly closed when in operation.

Wiring must comply with the National Electrical Code or Canadian Electrical Code and the local authority having jurisdiction.

The Model 191XL Series LED Beacon should be installed per the NEC or CEC, STATE and LOCAL CODES. Alternate installation locations and/or orientations should only be performed with the approval of the authority having jurisdiction. In addition, the unit can be mounted using an optional ceiling mount or optional wall mount.

⚠ WARNING

SHOCK HAZARD—*To avoid electrical shock hazards, do not connect wires while power is applied.*

NOTE: Model 191XL that are 24 V models are designed to operate on AC and DC supply voltages. The 120–240 Vac model is designed to operate 100 Vac to 265 Vac at 50/60 Hz. See Table 1 on page 7 for electrical ratings.

NOTICE

REVERSE POLARITY/MISWIRING—*The 191XL is not polarity sensitive, but MAY BE DAMAGED by incorrect electrical hookup. Damage will result if the voltage rating of the particular model is exceeded.*

Installation and Service Instructions

NOTE: Field terminations made inside of the surface mount enclosure will require the printed circuit board (PCB) assembly to be removed from the housing. See Figure 3 on page 15 and follow steps 1–4 and 6–8 of “Changing from Flash Mode to Steady Mode” on page 13 for the PCB removal and installation process.

The surface mount enclosure is not suitable for feed-through branch-circuit conductors.

Wiring 120-240, 277 Vac Models

The 120-240, 277 Vac models are supplied with three 24-inch leads: white, black, and green/yellow. Connect the black lead to the phase (hot) side of the power source and the white lead to the common (neutral) side of the power source. If required, the green/yellow lead in the housing is provided for connection to an earth ground.

Wiring 24 Vac/dc Models

The 24 Vac/dc models are supplied with two 24" leads, one red and one black. Connect the red (+) lead to the positive or phase (hot) side of the power source and the black (–) lead to the negative or common (neutral) side of power source.

Safety Message to Maintenance Personnel

WARNING

Listed below are some important safety instructions and precautions you should follow:

- Read and understand all instructions before operating this system.
- Any maintenance to the light system must be done with power turned off.
- Any maintenance to the light system must be performed by a trained electrician who is thoroughly familiar with all applicable national and local codes in the country of use.
- Do not connect this beacon to the system when power is on.

- Do not disconnect the beacon while circuit is live or unless the area is known to be free of ignitable concentrations. Keep the beacon tightly closed when in operation.
- Never alter the unit in any manner. Safety of the unit may be affected if additional openings or other alterations are made to the internal components or housing.
- The nameplate should NOT be obscured, as it contains cautionary and/or other information of importance to maintenance personnel. Ensure the nameplate remains readable if the housing exterior is painted.
- If the dome is damaged in any way, it MUST be replaced.
- After performing any maintenance, test the light system to ensure that it is operating properly.

Failure to follow all safety precautions and instructions may result in property damage, serious injury, or death to you or others.

Changing from Flash Mode to Steady Mode

WARNING

EXPLOSION HAZARD—To prevent ignition of hazardous atmospheres, disconnect the fixture from the supply circuit before opening it.

WARNING

***EXPLOSION HAZARD
Do not disconnect the beacon while circuit is live or unless the area is known to be free of ignitable concentrations. Keep the beacon tightly closed when in operation.***

WARNING

EXPLOSION HAZARD—To maintain the vapor-tight enclosure, do not damage the dome or threads while disassembling or reassembling the unit. Lubricated threaded joints exposed for long periods of time may attract small particles of dirt or other foreign materials. Housing and cover joints should be reassembled immediately, with all the threads fully engaged.

Installation and Service Instructions

To change from the default Steady Mode to Flashing Mode.

1. Disconnect power to the device.
2. See Figure 3 on page 15. Remove the threaded dome assembly by twisting it counterclockwise.
3. Using a No. 2 Phillips screwdriver, remove two #8-32 pan-head screws holding the printed circuit board assembly to the die-cast housing. Be sure to retain the two nylon screw bushings isolating the bracket from the screws.
4. Gently lift the printed circuit board (PCB) assembly from the housing and turn the assembly over to access the component side of the printed circuit board.
5. See Figure 4 on page 16. Locate jumper J3 and lift the jumper to remove it from “Flash” setting. Re-seat the jumper over the pins labeled “Steady.”
6. Place the printed circuit board assembly back into housing, making sure that four insulating pads are seated between the metal bracket and die-cast housing. The bracket must be oriented so that the notch in the bracket is aligned with the ground screw in the die-cast housing. This step must be carefully followed to prevent arcing and dielectric failure.
7. Slide two #8-32 pan-head screws into the screw bushings and tighten screws to secure the printed circuit board assembly to the die-cast housing.
8. Thread the dome assembly back onto the housing by turning it clock-wise to tighten.

 WARNING

SHOCK HAZARD

To avoid electrical shock hazards, do not connect wires while power is applied.

9. Reconnect the beacon to power.

10. Test the device by applying power and verifying the steady operation of the LED lamp.

Figure 3 PCB removed from housing

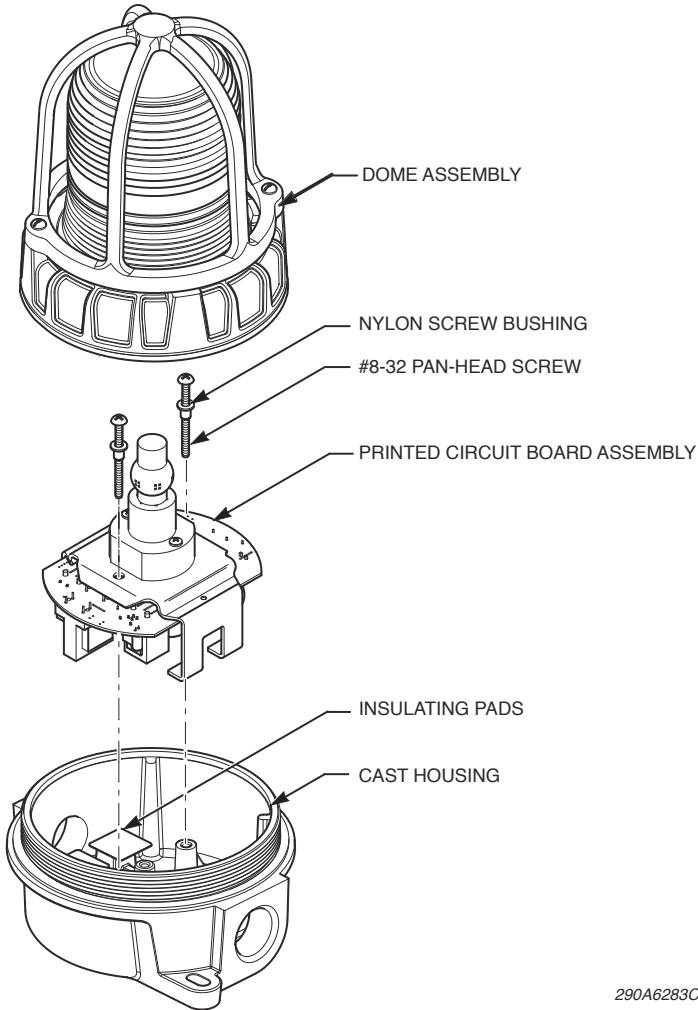

290A6283C

Figure 4 Location of jumper J3 on PCB

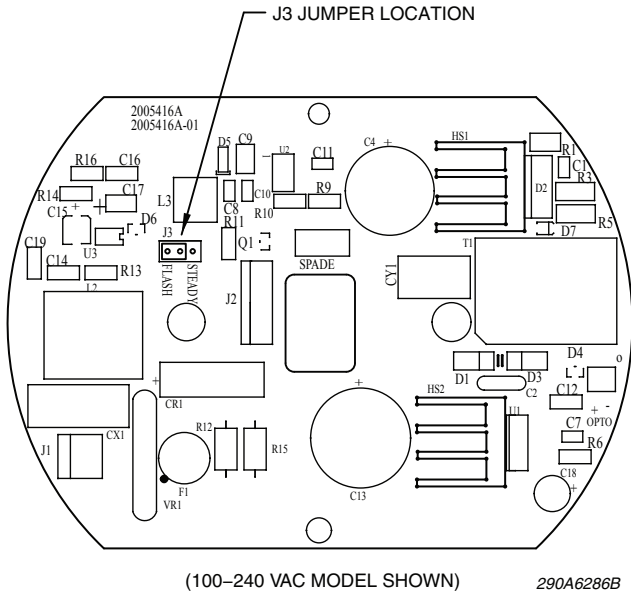

Cleaning the Fixture

⚠ WARNING

EXPLOSION HAZARD—Never use an abrasive material or file to remove corrosive materials from threaded surfaces. In extremely corrosive locations, equipment should be periodically inspected to guard against unusual deterioration and possible porosity, since this may weaken the enclosure structurally.

Maintenance procedures sometimes require fixtures to be hosed down for good housekeeping. The circuit should be turned off prior to hosing down the fixture.

The fixture should be cleaned periodically to maintain maximum light output. Only mild, non-abrasive cleaning agents should be used. The glass dome should be regularly inspected for scratches and chips, and if damaged, MUST be replaced.

Lubricating the Threaded Joint

The threaded joint on the cover should be kept well lubricated with a corrosion inhibiting grease such a petrolatum or soap-thickened mineral oil. If corrosive materials have accumulated on the threaded joints and cannot be removed with solvents, the parts should be discarded and replaced.

Getting Service, Assistance, and Parts

Please call 1-877-289-3246 for service, assistance and replacement parts. For instruction manuals and information about related products, please go to <http://www.federsignal-indust.com>.

⚠ WARNING

EXPLOSION HAZARD—Substitution of components may impair suitability for Class I, Division 2.

Typical spare parts are listed below. Due to certification, certain component parts are not available for field replacement. Units with this type of damage must be either replaced entirely or returned to Federal Signal for service.

Table 4 Replacement parts

Description	Part Number
Dome Assy., Red	K8449078
Dome Assy., Amber	K8449078-01
Dome Assy., Clear	K8449078-04
Dome Assy., Blue	K8449078-06
Dome Assy., Green	K8449078-07
Gasket	K8449080
Grease, 8 oz Tube	KR81-05-01
Dome Guard	K8449090
LED Emitter, Amber	K147169-06
LED Emitter, Blue	K147169-07
LED Emitter, Green	K147169-08
LED Emitter, Red	K147169-09
LED Emitter, Clear	K147169-10

Returning the Product for Credit

Product returns for credit require a return authorization from your local distributor prior to returning the product to Federal Signal. Please contact your distributor for assistance.

A product is qualified to be returned for credit when the following conditions are met:

- Product is resalable and in the original cartons
- Product has not been previously installed
- Product is the current revision
- Product has not been previously repaired
- Product is a standard product
- Product is not a service part

All returns are subject to a re-stock fee.

Defective products that are returned within the warranty period will be repaired or replaced at Federal Signal's sole discretion. Defective products do not include those products with lamp failure.

Circumstances other than those listed above will be addressed on a case-by-case basis.



FEDERAL SIGNAL

Safety and Security Systems / **Industrial**

Industrial Systems

2645 Federal Signal Drive • University Park, IL 60484-3167

Tel: 1-877-289-3246 • Fax: 708-534-4852

www.federal-signal-indust.com • www.fs-isys.com