

Electraray® Supervised Hazardous Location Strobe Warning Light



DESIGNED FOR USE IN HAZARDOUS LOCATIONS

- 24VDC
- Four wires and supervisory diode
- Six lens colors
- 10,000 hour, high-intensity strobe tube
- 1/2-inch NPT pipe mount
- Type 4X, IP66 enclosure
- CSFM Approved
- CSA Certified
- UL and cUL Listed

Model 224XST

Federal Signal's Electraray® Model 224XST hazardous location strobe light provides 80 high-intensity flashes per minute. This warning light is available in 24VDC.

The Model 224XST has been certified by UL as meeting Type 4X water-tight and corrosion resistant requirements, constructed to IP66. This hazardous location warning light has a black polyurethane coated base and the inner fresnel lens is available in six colors (including magenta). The clear polycarbonate outer dome can be quickly removed for easy access to inspect the unit or change the lamp. The 224XST has an effective candela of 240 and a 580,000 peak candela.

The 224XST is UL Listed, CSA Certified and CSFM Approved for Class I, Division 2, Groups A, B, C and D; Class II, Division 2, Groups F and G; and Class III.

The 24VDC 224XST features a voltage in-rush limiting PCB design that provides greater compatibility control systems and less electrical interference with in-rush sensitive devices.

The Electraray 224XST contains a supervisory diode and four wire leads, for fire alarm applications.

Model 224XST is ideal for wet, corrosive atmospheres like those found in food processing industries, or anywhere a visual signal is needed.

Federal Signal's affordable Electraray Strobe Warning Light is specifically designed for use in hazardous locations or where corrosive materials are present.

Model	Voltage	Operating Current	Flash Rate/Minute	Candela Peak ¹	ECP ²	Mount
224XST	24VDC	0.7 amps (2.0 amp, in-rush)	80	580,000	240	1/2" NPT Pipe

Hazardous Location Rating:

T-Code at Maximum Ambient Temperature, °C

Hazardous Location	40°C
Class I, Div 2, Groups A, B, C, D	T2A/280
Class II, Div 2, Groups F, G	T5/100
Class III	T5/100

¹ Peak candela is the maximum light intensity generated by a flashing light during its light pulse

² ECP (Effective Candela) is the intensity that would appear to an observer if the light were burning steadily



ELECTRARAY® HAZARDOUS LOCATION WARNING LIGHT (224XST)

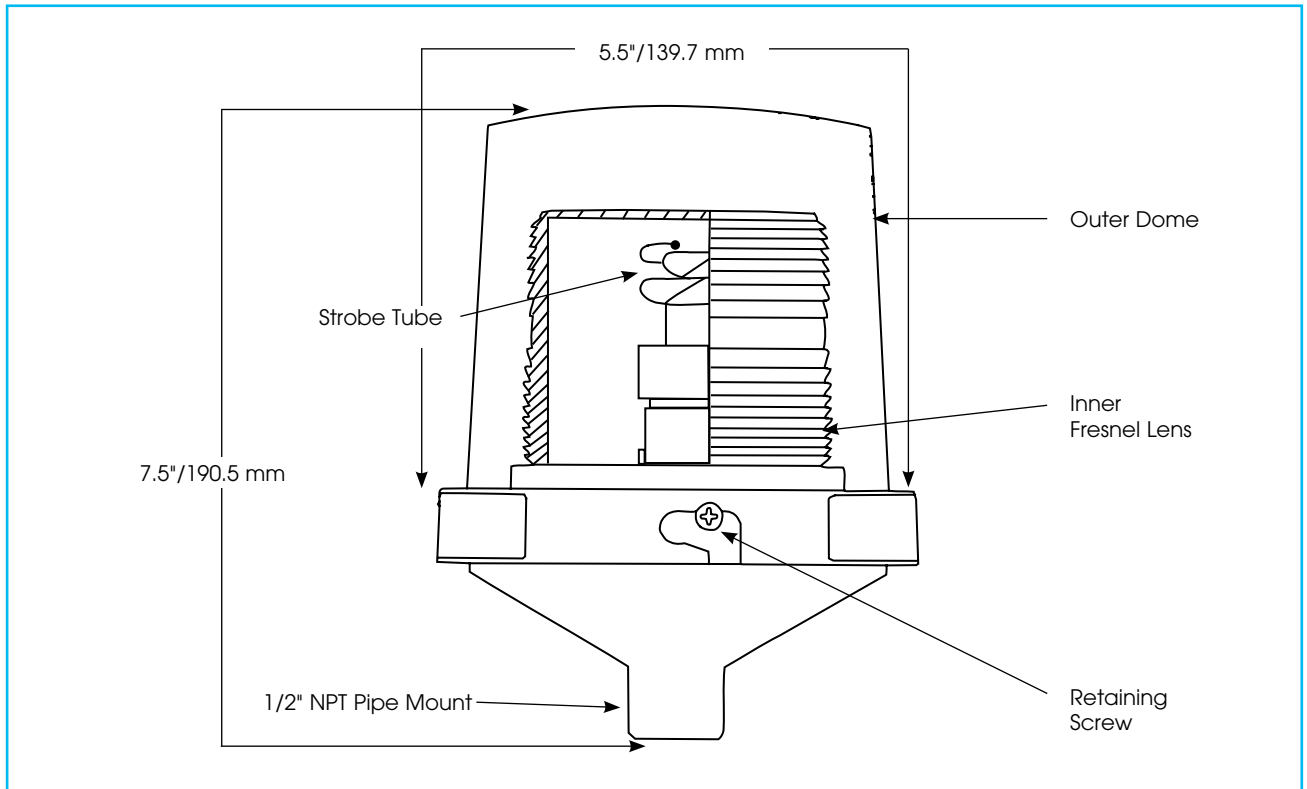

SPECIFICATIONS

Lamp Life:	10,000 Hours	10,000 Hours
Lamp Source:	Strobe	Strobe
Operating Temperature:	-40°F to 104°F	-40°C to 40°C
Net Weight:	1.5 lbs.	0.68 kg
Shipping Weight:	2.0 lbs.	0.9 kg
Height:	7.5"	190.5 mm
Diameter:	5.5"	139.7 mm

HOW TO ORDER

- Specify model, voltage and color
- Please refer to Model Number Index 224XST beginning on page 377

REPLACEMENT PARTS

<u>Description</u>	<u>Part Number</u>	<u>Description</u>	<u>Part Number</u>
Interior Lens		Exterior Dome, Clear	K8444D219C-04
Amber	K8550C095A-02	PC Assembly, 24VDC	K2001202C-01
Blue	K8550C095A-01	Strobe Tube	K8107177A
Clear	K8550C095A		
Green	K8550C095A-04		
Magenta	K8550C095A-07		
Red	K8550C095A-03		