



**FEDERAL SIGNAL**

Safety and Security Systems / **Industrial**

*Advancing security and well being*

## **Commander® Rotating Light Models 371-120 and 371L-120**



---

### ***Installation and Maintenance Manual***

256914G  
REV. G 811  
Printed in U.S.A.



**Warranty** – Seller warrants all goods for five years on parts and 2-1/2 years on labor, under the following conditions and exceptions: Seller warrants that all goods of Seller's manufacture will conform to any descriptions thereof for specifications which are expressly made a part of this sales contract and at the time of sale by Seller such goods shall be commercially free from defects in material or workmanship. Seller reserves the right at the Seller's discretion to "Repair and Return" or "Replace" any item deemed defective during the warranty period. This warranty does not cover travel expenses, the cost of specialized equipment for gaining access to the product, or labor charges for removal and reinstallation of the product. This warranty shall be ineffective and shall not apply to goods that have been subjected to misuse, neglect, accident, damage, improper maintenance, or to goods altered or repaired by anyone other than Seller or its authorized representative, or if five years have elapsed from the date of shipment of the goods by Seller with the following exceptions: lamps and strobe tubes are not covered under this warranty. Outdoor warning sirens and controllers manufactured by Federal Warning Systems are warranted for two years on parts and one year on labor. No agent, employee, representative or distributor of Seller has any authority to bind the Seller to any representation, affirmation, or warranty concerning the goods and any such representation, affirmation or warranty shall not be deemed to have become a part of the basics of the sales contract and shall be unenforceable. THE FOREGOING WARRANTIES ARE EXCLUSIVE AND IN LIEU OF ALL OTHER WARRANTIES OR MERCHANTABILITY, FITNESS FOR PURPOSE AND OF ANY OTHER TYPE, WHETHER EXPRESS OR IMPLIED. These warranties shall not apply unless Seller shall be given reasonable opportunity to investigate all claims for allegedly defective goods. Upon Seller's instruction a sample only of allegedly defective goods shall be returned to Seller for its inspection and approval. The basis of all claims for alleged defects in the goods not discoverable upon reasonable inspection thereof pursuant to paragraph 8 hereof must be fully explained in writing and received by Seller within thirty days after Buyer learns of the defect or such claim shall be deemed waived.



Industrial Systems

2645 Federal Signal Drive • University Park, IL 60484-3167

Tel: 708-534-4756 • Fax: 708-534-4852

Email: [elp@federalsignal.com](mailto:elp@federalsignal.com) • [www.federalsignal-indust.com](http://www.federalsignal-indust.com)

---

# Contents

<b>Safety Messages to Installers .....</b>	<b>5</b>
<b>An Overview of Models 371-120 and 371L-120 .....</b>	<b>6</b>
<b>Unpacking the Light .....</b>	<b>7</b>
<b>Mounting the Light .....</b>	<b>8</b>
Pipe Mounting the Light .....	8
Surface Mounting the Light .....	9
<b>Adjusting the Light Beam .....</b>	<b>9</b>
<b>Wiring the Light .....</b>	<b>10</b>
<b>Safety Messages to Maintenance Personnel .....</b>	<b>13</b>
<b>Replacing the Lamp .....</b>	<b>14</b>
<b>Maintaining the Model 371/371L.....</b>	<b>15</b>
<b>Getting Service, Assistance, and Parts .....</b>	<b>16</b>
Repair Service .....	16
Technical Assistance.....	16
Accessories and Replacement Parts .....	17

## Tables

<b>Table 1</b> Electrical and environmental ratings.....	<b>7</b>
<b>Table 2</b> Dimensions.....	<b>7</b>
<b>Table 3</b> Replacement parts .....	<b>17</b>
<b>Table 4</b> Accessories .....	<b>17</b>

**Figures**

**Figure 1** Mounting options .....8  
**Figure 2** Adjusting the light beam ..... 10  
**Figure 3** Connecting leads to the terminal block..... 12  
**Figure 4** Replacing the lamp..... 15

## **Safety Messages to Installers**

### **⚠ WARNING**

It is important to follow all instructions shipped with this product. This device is to be installed by a trained electrician who is thoroughly familiar with the National Electrical Code and/or Canadian Electrical Code and will follow the NEC and/or CEC Guidelines as well as all local codes. This light should be considered a part of the warning system and not the entire warning system.

The selection of the mounting location for the light, its controls and the routing of the wiring are to be accomplished under the direction of the facilities engineer and the safety engineer. In addition, listed below are some other important safety instructions and precautions you should follow:

- Read and understand all instructions before installing or operating this light.
- Do not connect this light to the system when power is on.
- After installation, make sure that all set screws and threaded joints are properly tightened.
- After installation, test the light to make sure that it is operating properly.
- After testing is complete; provide a copy of this instruction booklet to all personnel.
- Establish a procedure to routinely check the light for proper activation and operation.

Failure to follow all safety precautions and instructions may result in property damage, serious injury, or death.

## **An Overview of Models 371-120 and 371L-120**

Federal Signal Models 371-120 and 371L-120 incandescent warning lights have a powerful sealed beam lamp that rotates 360 degrees within a glass or polycarbonate dome. Power is delivered to the Commander® rotating lamp by a unique collector ring. The lamp itself is mounted in a pivoting yoke. This allows the beam angle to be adjusted through 90 degrees from horizontal to vertical. Changing the beam angle enables the you to create unique light patterns and direct the light for better visibility.

The Model 371 features a 200-watt sealed-beam lamp and a high-temperature-resistant glass dome. The glass dome of the 371 is ideal for applications such as steel mills or arc furnaces/smelters where high ambient temperatures or red hot materials would melt or damage the dome. The Model 371 is available in three colors: amber, blue, and red.

The Model 371L features a 100-watt sealed-beam lamp and an impact-resistant polycarbonate dome. The thinner polycarbonate dome allows more light to pass through while protecting the lamp. The Model 371L is available in five colors: amber, blue, clear, green, and red. The dome-and-ring assembly screws on, providing access to the interior of the light.

The base features textured black powder paint for greater corrosion-resistance. Wiring can be routed through the pipe-mount opening in the bottom of the light or the two side knockouts can be used for side entry wiring. Installation can be surface or 1-inch NPT pipe mount.

Optional wall and corner mount brackets are available. The LWMB2 wall-mount bracket and the LCMB2 corner-mount bracket can be used to mount the Model 371/371L. For surface mounting on solid substrates, the separately purchased Model 371BRCKT three-point surface-mount bracket is available.

The 371-120 and 371L-120 are Type 4X, IP66 rated, UL and cUL Listed and CSA Certified.

## Unpacking the Light

After unpacking the light, examine it for damage that may have occurred in transit. If the light has been damaged, do not attempt to install or operate it. File a claim immediately with the carrier, stating the extent of the damage. Carefully check all envelopes, shipping labels, and tags before removing or discarding them. Disposal of all shipping materials must be carried out in accordance with national and local codes and standards. If any parts are missing, please call Federal Signal Customer Support at 708-534-4756.

**Table 1** Electrical and environmental ratings

Operating Voltage:	120 Vac 50Hz/60Hz
Flash Rate:	60 FPM
Candle Power: 371 371L	36,000 20,000
Lamp Life:	2,000 Hours
Light Source: 371 371L	200 W Sealed Beam 100 W Sealed Beam
Operating Temperature:	-31 °F to 150 °F (-35 °C to 66 °C)
Environmental Ratings:	Type 4X, IP66

**Table 2** Dimensions

Height:	11.38 in (288.9 mm)
Diameter:	9.12 in (231.6 mm)
Net Weight: 371 371L	13.25 lb (6.0 kg) 9.8 lb (4.4 kg)
Shipping Weight: 371 371L	14.3 lb (6.5 kg) 10.8 (4.9)

## Mounting the Light

The Model 371/371L light is designed for mounting on a flat horizontal surface or on a 1" NPT pipe. For surface mounting on solid substrates, the separately purchased Model 371BRCKT surface mounting bracket can be used. If conduit side-entries are to be used, disassemble the light as described in “Wiring the Light” on page 10 and remove one or more knockouts with a blunt tool before mounting the light. Use a file to remove excess flash around the knockout.

**Figure 1** Mounting options

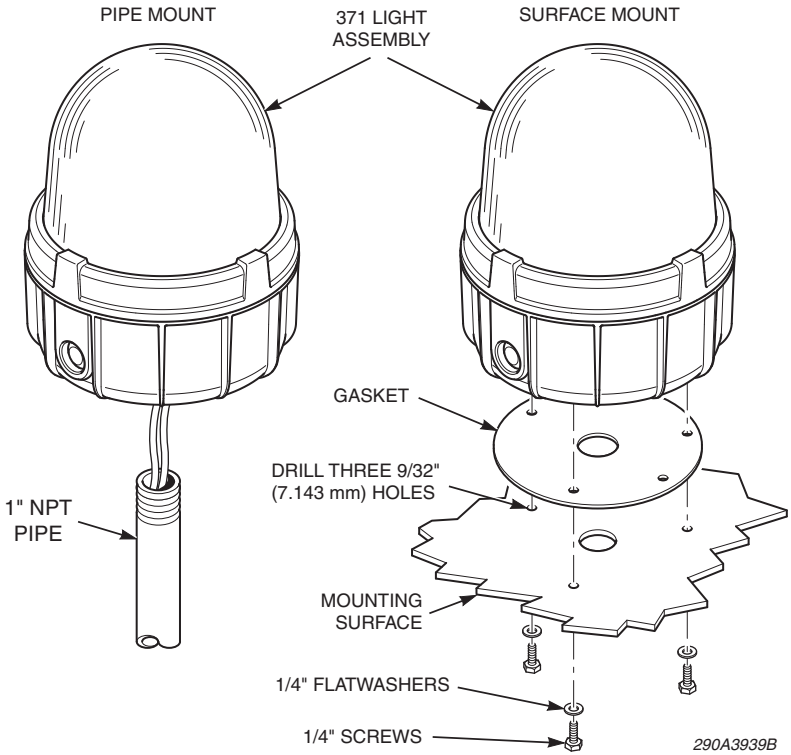

### **Pipe Mounting the Light**

Attach the light to the 1-inch NPT pipe by threading the light clockwise on the pipe (Figure 1). For information on making the electrical connections, see “Wiring the Light on page 10.”



## **Surface Mounting the Light**

To mount the light on a flat surface:

1. Using the gasket as a template, scribe four drill-position marks on the mounting surface (Figure 1).
2. Drill a 9/32" (7.1 mm) diameter hole at each of the outside drill position marks for mounting.
3. Drill or punch a 1-3/8" (34.9 mm) diameter hole at the center drill-position mark for the wire entry.
4. Attach suitable 1" NPT hub or connector to conduit entrance in bottom of light. For Type 4X/IP66 applications, the hub or connector must be suitably rated (Myers® STTTB-2 or T&B® H100-TB hubs are recommended.)
5. Set the light on the gasket and attach it to the mounting surface with the provided 1/4" screws and washers.
6. For information on making the electrical connections, see the next section.

## **Adjusting the Light Beam**

The light is shipped from the factory with the lamp in the horizontal position. To change the angle of the lamp:

1. See Figure 2 on page 10. Remove the dome assembly by grasping the die-cast ring attached to the dome and turning it counter-clockwise.
2. Remove the locking screw.
3. Loosen the two pivot screws and adjust the lamp to the desired position.
4. Tighten the two pivot screws to secure the lamp in position.
5. Reinstall the dome assembly.

**Figure 2** Adjusting the light beam

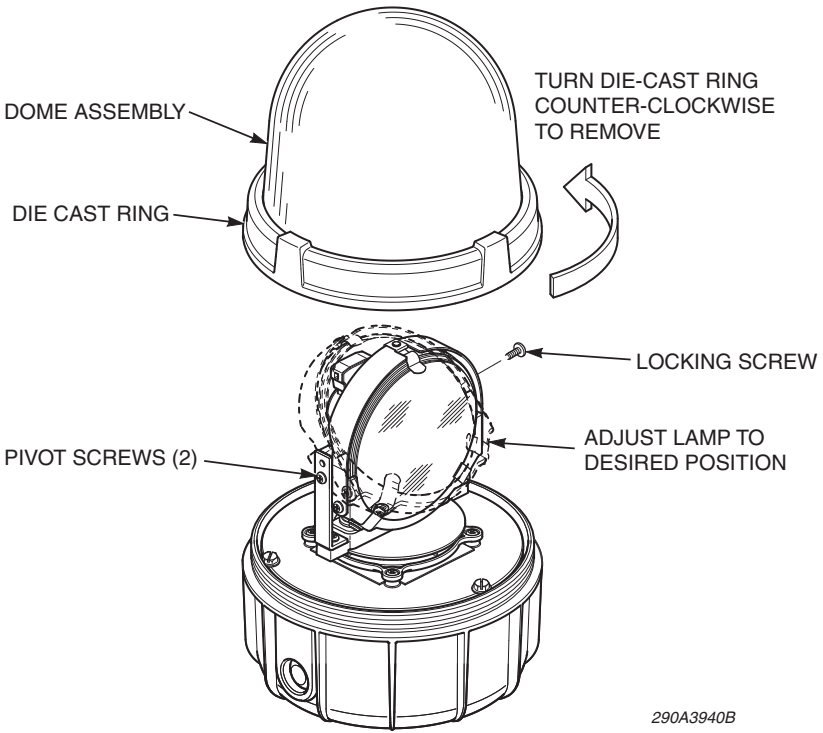

## Wiring the Light

**⚠ WARNING**

**SHOCK HAZARD**

**To avoid electrical shock hazards, do not connect wires while power is applied.**

The Model 371/371L comes assembled from the factory with two color-coded leads for wiring to a junction box. If desired, the factory leads can be removed and the supply connections can be directly made to the terminal block located on the backside of the motor mounting base as described below

1. Disassemble the light (Figure 3 on page 12):
  - a) Remove dome assembly by grasping the die-cast ring attached to the dome and turning it counter-clockwise.
  - b) Remove three #10 hex head screws that secure motor mounting base to housing.
  - c) Remove motor mounting base.
  - d) If desired, remove the factory supplied leads from the terminal block.
2. If you are using conduit side-entries, attach a Myers® STTTB-2 or a T&B® H075TBH 3/4-inch NPT conduit hub with a 3/4-inch NPT close nipple (both user-supplied) to the housing and tighten the hub securely. When side entries are used, the bottom 1-inch NPT conduit entry must be plugged with a threaded plug (user-supplied). (See Table 4 Accessories” on page 17).
3. Route the supply wires (10 AWG to 16 AWG) into the light housing, taking care to keep wires clear of the motor fan.
4. Strip a maximum of 0.28 in (7 mm) of insulation from the ends of the power leads. Connect the wires to the terminal block by inserting the stripped ends of the wires into the connectors as far as they can travel.
5. Tighten the clamping screw. The maximum tightening torque is 7.0 in-lb (0.8 N•m).

**IMPORTANT: Proper grounding of the light requires two connections to a solid earth ground.**

6. See Figure 3 on page 12. Connect the earth ground to the terminal block and the green ground screw located in light housing.
7. Reassemble the light and test it for proper operation.

**Figure 3** Connecting leads to the terminal block

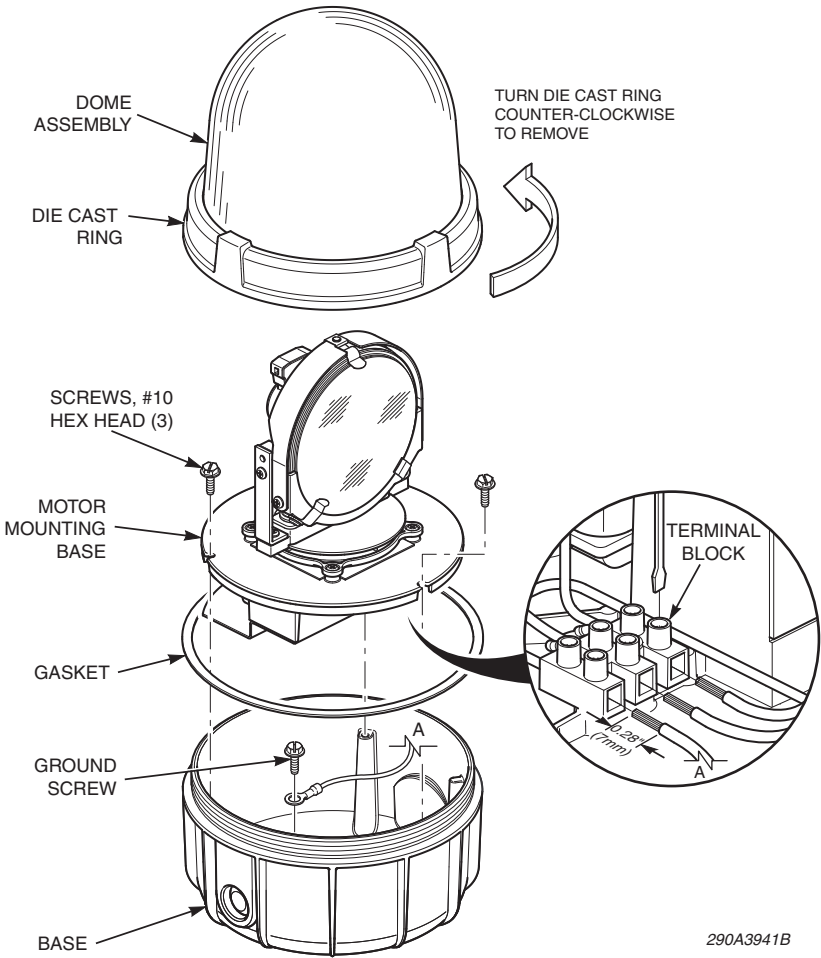

## **Safety Messages to Maintenance Personnel**

Listed below are some important safety instructions and precautions you should follow:

- Read and understand all instructions before operating this system.
- Any maintenance to the light system must be done with the power turned off.
- Any maintenance to the light system must be performed by a trained electrician in accordance with NEC/CEC Guidelines and local codes.
- Never alter the unit in any manner. Safety may be endangered if additional openings or other alterations are made to units.
- The nameplate, which contains cautionary or other information of importance to maintenance personnel, should not be obscured.
- If the dome is damaged in any way, the complete dome assembly **MUST** be replaced.
- After performing any maintenance, test the light system to ensure that it is operating properly.

Failure to follow all safety precautions and instructions may result in property damage, serious injury, or death.

## Replacing the Lamp

**⚠ WARNING**

**SHOCK HAZARD**

*To avoid electrical shock hazards, do not connect wires while power is applied.*

1. Disconnect power to the light.
2. Remove the dome assembly by grasping the die-cast ring attached to the dome and turning it counter-clockwise.

**NOTE:** If the dome assembly is difficult to remove, place a screwdriver blade against one of the four bosses on the die-cast ring attached to the dome. Gently tap the screwdriver handle to loosen the dome assembly from the housing.

**⚠ WARNING**

**MAINTAIN WATERTIGHTNESS**

*To maintain the watertight enclosure, do not damage dome or threads while disassembling or reassembling the unit. Lubricated threaded joints exposed for long periods of time may attract small particles of dirt or other foreign materials. Re-assemble joint immediately after performing maintenance.*

3. Lift the connector from the lamp terminals.
4. Lift the spring clip at the top of the lamp and rotate the curved lamp retainer toward the front of the lamp. Lift out the lamp.
5. Install the replacement lamp by placing the edge of the lamp into the groove of the die-cast lampholder. Rotate the lamp so that its prongs point straight up.
6. Rotate the lamp retainer up until the spring clip snaps over the edge of the lamp.
7. Replace the connector on the lamp terminals.
8. Replace the dome assembly by turning it clockwise until it is seated securely against the gasket.
9. Test the light for proper operation.

**Figure 4** Replacing the lamp

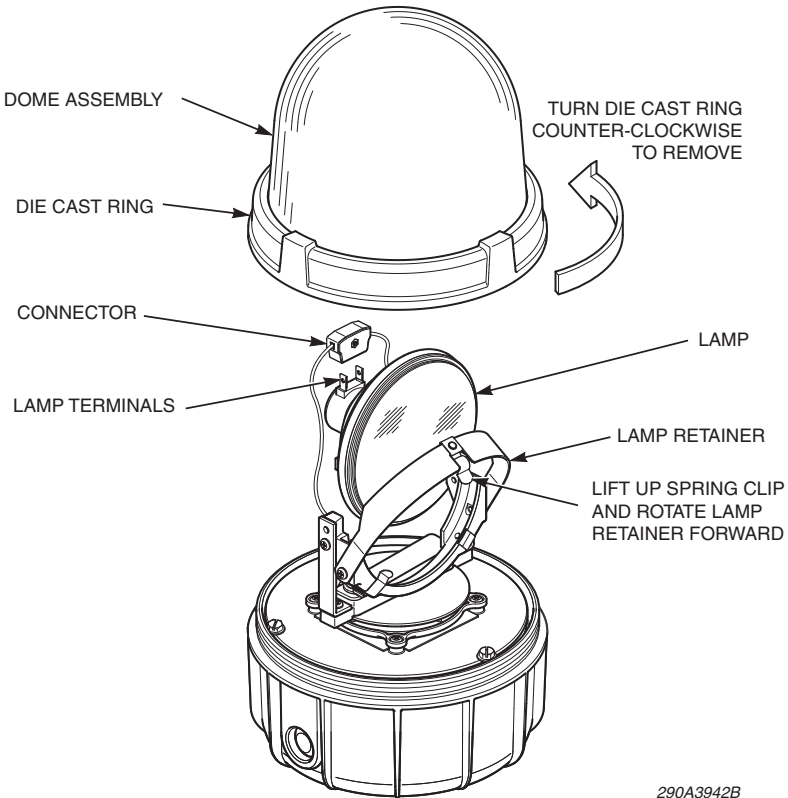

## **Maintaining the Model 371/371L**

Establishing a regular maintenance schedule for the Model 371/371L extends the life of the light and ensures safety. Periodically check that the light operates properly. Also, inspect the dome for cracks, crazing (hairline cracks), discoloration, and other defects.

- Lubricate the lamp shaft bearings with a light machine oil every 12 months or 5,000 hours of service, whichever comes first.
- The worm and worm gear rarely require lubrication. However, if lubrication is required use a light high-quality grease.

## ***Installation and Maintenance Instructions***

---

- The motor is equipped with sealed bearings and requires no maintenance.
- The threaded dome ring joint should be well lubricated with petroleum or a soap-thickened mineral oil. If corrosive products have accumulated on joints and cannot readily be removed with solvents, the parts should be discarded and replaced.

### **Cleaning the Dome**

**NOTE:** Maintenance procedures sometimes require fixtures to be hosed down for good housekeeping. The electrical circuit should be turned off prior to hosing down the light.

Clean the dome periodically to maintain maximum light output. Use only mild, non-abrasive cleaning agents.

### **Getting Service, Assistance, and Parts**

Federal Signal will service your product and provide technical assistance and support. Please call the phone numbers listed below. For instruction manuals and information about related products, please go to <http://www.federal-signal-indust.com>.

#### ***Repair Service***

Products returned for repair require a Return Authorization form. To obtain service for the product, please contact the Federal Signal Service Department at 708-534-4858.

#### ***Technical Assistance***

For technical assistance, please call Technical Support at 708-534-3424, extension 5823.



## **Accessories and Replacement Parts**

To order accessories and replacement parts, please call Federal Signal Customer Support at 708-534-4756.

**Table 3** Replacement parts

<b>Description</b>	<b>Part Number</b>
Plastic Dome Assembly, Amber (371L)	K8459125
Plastic Dome Assembly, Blue (371L)	K8459125-01
Plastic Dome Assembly, Clear (371L)	K8459125-02
Plastic Dome Assembly, Green (371L)	K8459125-03
Plastic Dome Assembly, Red (371L)	K8459125-04
Glass Dome Assembly, Amber (371)	K8459126
Glass Dome Assembly, Blue (371)	K8459126-01
Glass Dome Assembly, Red (371)	K8459126-02
Gasket, Dome Ring	K8459123
Gasket, Surface Mount	K8459127
Lamp, 100 W, (125 V/130 V) (100PAR46/3NSP)	K8107A130
Lamp, 200 W, (125 V/130 V) (200PAR46/3NSP)	K8442A039
Kit, Motor Replacement	K8459A113
Brush and Spring	8442A028

**Table 4** Accessories

<b>Description</b>	<b>Part Number</b>
Wall Mount Bracket	LWMB2
Corner-Mount Bracket	LCMB2
Mounting Bracket, Surface	371BRCKT
Kit, Shock Mount	K8459A076
Conduit Hub Kit, 3/4" NPT	K8459138
Close-Up Plug, 1" NPT	K8459130

Commander is a registered trademark of Federal Signal Corporation.  
Myers is a registered trademark of Coopers Industries.  
T&B is a registered trademark of Thomas & Betts Corporation.





**FEDERAL SIGNAL**

Safety and Security Systems / **Industrial**

*Advancing security and well being*

Industrial Systems

2645 Federal Signal Drive • University Park, IL 60484-3167

Tel: 708-534-4756 • Fax: 708-534-4852

Email: [elp@federalsignal.com](mailto:elp@federalsignal.com) • [www.federalsignal-indust.com](http://www.federalsignal-indust.com)

© 2011 Federal Signal Corporation. All rights reserved.