



AudioMaster® Public Address 15 Watt Speaker

Model AM15

PUBLIC ADDRESS FOR INDUSTRIAL ENVIRONMENTS

- Eight ohm
- 15 watt
- Re-entrant horn design
- Wall mount
- 1/2-inch conduit openings
- Type 3R enclosure
- UL 1480 Approved and cUL Listed

The Federal Signal Model AM15 is a rugged, re-entrant speaker for use in public address or paging applications. This 15 watt speaker features a rugged speaker cone and projector constructed of spun aluminum. The speaker wiring connections are enclosed in a dust- and moisture-proof, die-cast aluminum compartment. All external surfaces are sealed with gray powder coat paint.

Two screws inserted through the back of the wiring compartment provide for simple wall mount installation. The bottom of the AM15 contains two 1/2-inch conduit openings to accommodate inbound and outbound audio wiring. The unique shape of the AM15 projector provides a 60° sound dispersion. The projector is held in position with a Teflon coated lock ring that can be rotated 180° in order to obtain the desired sound distribution.

The AM15 is rated for indoor and outdoor use. This speaker is UL Listed.

The AM15 can be used with the AudioMaster® CTS series amplifiers and the AudioRouter™ to complete an industrial grade public address system.

Model	Power Handling	Frequency Response	Impedance	Beam Spread	Decibels @ 10'	Decibels @ 1m
AM15	15 watt	400-4000Hz	8 ohm	60°	110	120



PUBLIC ADDRESS SPEAKER (AM15)

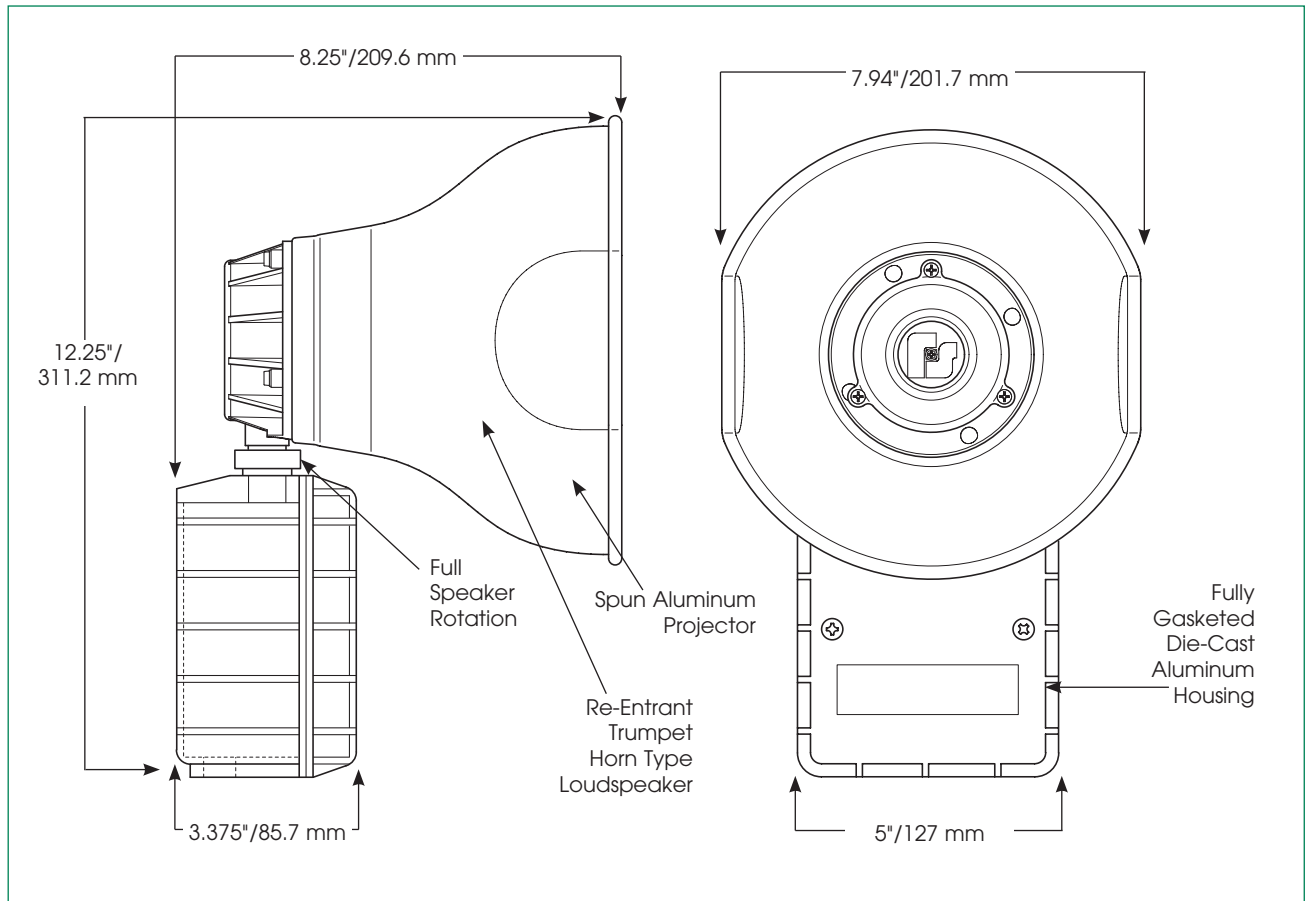

SPECIFICATIONS

Operating Temperature:	-40°F to 151°F	-40°C to 66°C
Net Weight:	4.85 lbs.	2.2 kg
Shipping Weight:	6.0 lbs.	2.72 kg
Height:	12.25"	311.2 mm
Width:	7.94"	201.7 mm
Depth:	8.25"	209.6 mm

HOW TO ORDER

- Specify model number
- Please refer to Model Number Index AM15 beginning on page 376