



Litestak® Status Indicator with LED Lamp

Model LSLD

LONG LIFE LIGHT SOURCE

- Available in 24VDC and 120VAC
- Five lens colors
- 100,000 hour, vibration-resistant LED lamp
- Surface mount and integrated 3/4-inch NPT pipe mount
- Indoor use only
- Type 1 enclosure
- UL and cUL Listed and CSA Certified

Federal Signal's Litestak® status indicators are vertical columns of light that indicate the status of a machine's operating process in a full 360° radius.

The Litestak Model LSLD modular indicator light system allows the user to combine up to five interchangeable lamp units with a base power unit. Modules are sold separately for a truly customized indicator.

Light modules come complete with a 100,000-hour LED lamp; LED light output coordinates with the module's impact-resistant polycarbonate lensing. LED lamps consume less power, operate at a lower temperature, and are remarkably resistant to vibration — which makes them perfect for use in heavy-duty, high vibration applications.

LED lamps are available in five colors — Amber, Blue, Clear, Green or Red. The standard double-contact bayonet base retrofits into any Federal Signal Litestak unit to replace original incandescent lamps.

An optional Sound Module (Models LSS or LSH) can be added to the top of the Litestak column to create a dual purpose audible/visual status indicating signal. The LSS sound module allows the user to select from 32 tones via a simple dip switch panel. In applications where a single loud tone is all that is necessary, the LSH piezo-electric horn is a perfect audible addition.

Litestak is a versatile system that allows the user to select either steady burn or flash. A flasher is included on the 120VAC LSB unit only but can be purchased separately for 24VDC models. The Litestak base unit can be either surface mount, or 3/4" NPT pipe mount.

Model	Voltage	Operating Current	Mount
LSB-024-240 ¹	24-240VAC/DC	N/A	3/4" NPT Pipe/Surface
LSB-120 ¹	120VAC 50/60Hz	N/A	3/4" NPT Pipe/Surface
LSBS ¹	24-240VAC/DC	N/A	Surface
LSLD-024 ²	24VDC	80 mA	N/A
LSLD-120 ²	120VAC 50/60Hz	45 mA	N/A

¹ Cap kit included.

² Includes lens, lamp and light module.



LITESTAK® WITH LED LAMP (LSLD)

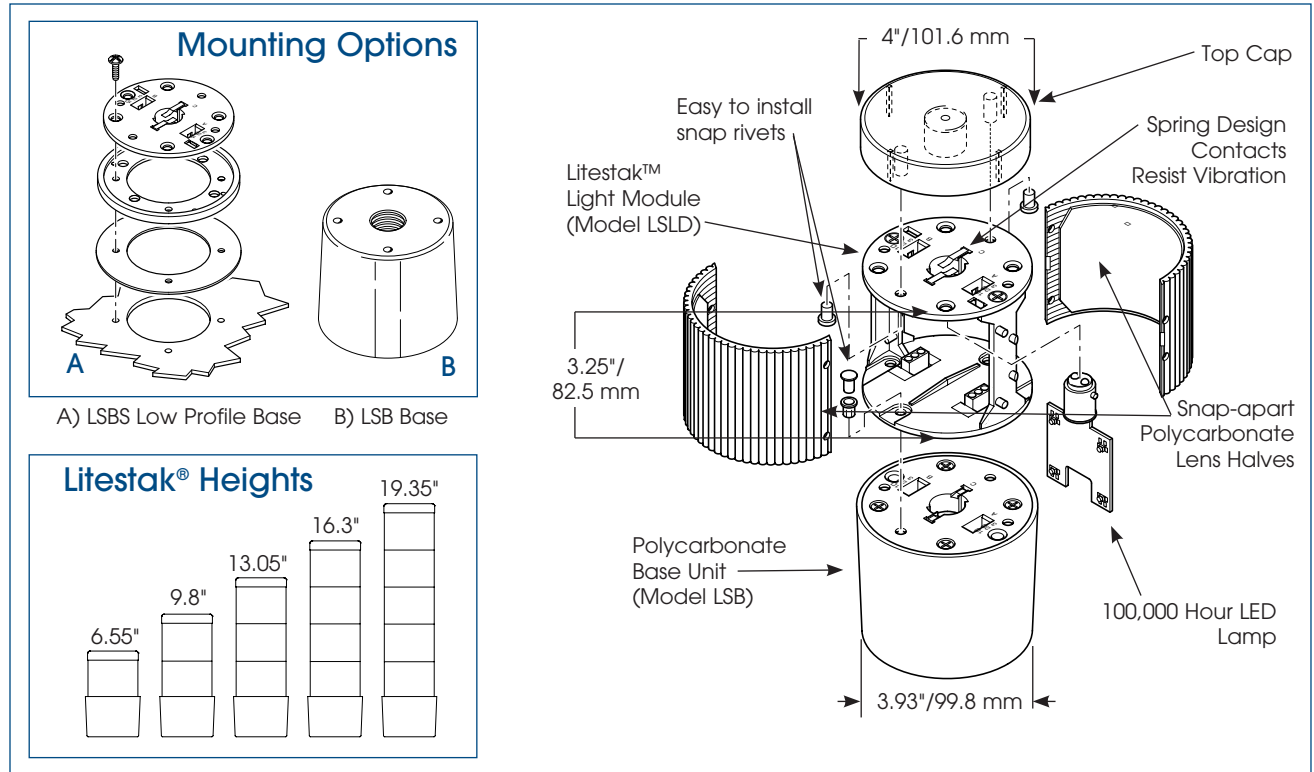

SPECIFICATIONS

Lamp Life:	100,000 Hours	100,000 Hours
Light Source:	LED Array	LED Array
Operating Temperature:	0°F to 120°F	-18°C to 49°C
Net Weight, LSLD:	0.45 lbs.	0.2 kg
Shipping Weight, LSLD:	0.7 lbs.	0.32 kg
LSLD Height:	3.25"	82.5 mm
LSB Height:	3.3"	83.8 mm
LSLD Diameter:	3.93"	99.82 mm
LSB Diameter:	3.93"	99.82 mm

HOW TO ORDER

- Light modules and base modules are ordered separately
- Specify model, voltage and color of light modules
- Specify model and voltage of base unit
- Specify optional sound module (page 24 & 26)
- Please refer to Model Number Index LSLD beginning on page 369

REPLACEMENT PARTS

<u>Description</u>	<u>Part Number</u>	<u>Description</u>	<u>Part Number</u>
Lens Kit, Amber	K8447014A-02	LED Lamp, Amber, 24VDC	LED-024ASB
Lens Kit, Blue	K8447014A-04	LED Lamp, Blue, 24VDC	LED-024BSB
Lens Kit, Clear	K8447014A-05	LED Lamp, Clear, 24VDC	LED-024CSB
Lens Kit, Green	K8447014A-01	LED Lamp, Green, 24VDC	LED-024GSB
Lens Kit, Red	K8447014A-03	LED Lamp, Red, 24VDC	LED-024RSB
Lens Kit, Black-out (1/2 lens)	K8447014A-06	LED Lamp, Amber, 120VAC	LED-120ASB
Flasher, 24VDC	K8285237A	LED Lamp, Blue, 120VAC	LED-120BSB
Flasher, 120VAC	K8285239A	LED Lamp, Clear, 120VAC	LED-120CSB
Cap Kit-Snap Rivets included	K8447009E	LED Lamp, Green, 120VAC	LED-120GSB
Snap Rivets, 25 pieces	K7099A112A-01	LED Lamp, Red, 120VAC	LED-120RSB