

# Visalert® Strobe Light

Model VALS

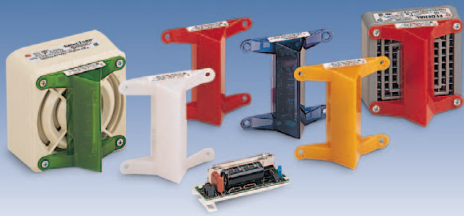

## STROBE WARNING LIGHT

- Available in 12VDC and 24VDC, 120VAC and 240VAC
- Five lens colors
- 4,000 hour strobe tube
- Surface mount on Federal Signal audible signaling devices or control panel
- Indoor/outdoor use
- Type 3R, IP44 enclosure
- UL Listed and CSA Certified

Federal Signal's Visalert® is a three dimensional, triangular warning light designed to be mated with Federal Signal's Model 350 Vibratone® horn and the Model 50GC SelecTone® speaker/amplifier. The Model VALS can also be used as a stand alone device. Visalert is available in five lens colors: Amber, Blue, Clear, Green and Red.

Knockouts on the 50GC, 350 and the 450 audible devices (sold separately) ensure easy installation. The units can be either independently or simultaneously wired with the audible device. Model VALS uses a linear strobe tube and all the circuitry is contained within the lens.

Visalert units are recommended for use in industrial applications and situations where effective visual warning is needed. The Visalert can be surface mounted on the Model 350 and 450 horn or Model 50GC speaker/amplifier.

Federal Signal's Visalert strobe light is an affordable, low-maintenance strobe light in a compact size that is perfect for control panel applications.

Model	Voltage	Operating Current	Flash Rate/Minute	Candela Peak <sup>1</sup>	Mount
<b>VALS-012</b> *	12VDC	0.18 amps	80	108,000	Surface
<b>VALS-024</b> *	24VDC	0.08 amps	80	108,000	Surface
<b>VALS-120</b> *	120VAC 50/60HZ	0.06 amps	80	108,000	Surface
<b>VALS-240</b> *	240VAC 50/60HZ	0.03 amps	80	108,000	Surface

\* Indicates color: (A) Amber, (B) Blue, (C) Clear, (G) Green or (R) Red

<sup>1</sup> Peak candela is the maximum light intensity generated by a flashing light during its light pulse



## VISALERT® STROBE LIGHT (VALS)

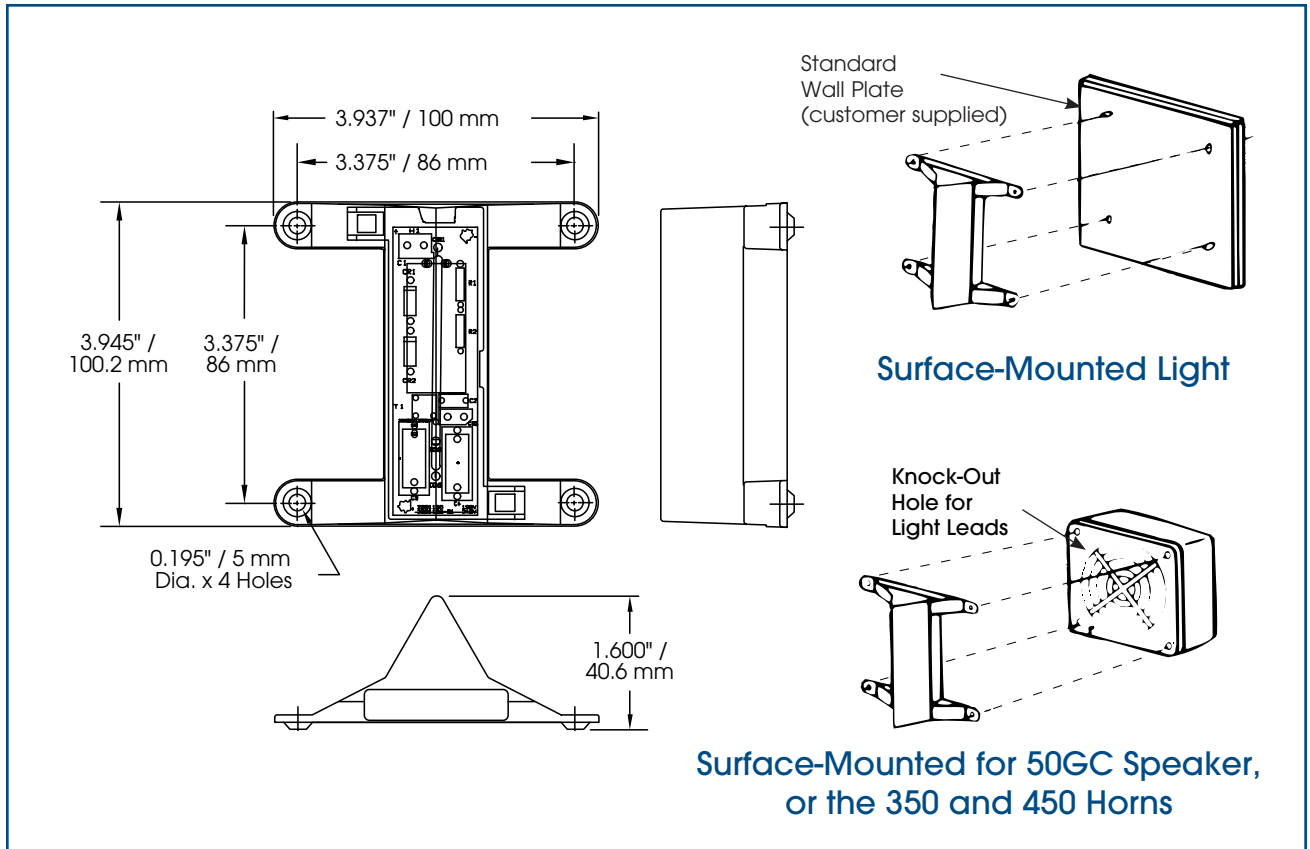

### SPECIFICATIONS

Lamp Life:	4,000 Hours	4,000 Hours
Light Source:	Strobe tube	Strobe tube
Operating Temperature:	-31°F to 150°F	-35°C to 66°C
Net Weight:	0.1 lbs.	0.057 kg
Shipping Weight:	0.25 lbs.	0.113 kg
Height:	3.95"	100.3 mm
Width:	3.94"	100.0 mm
Depth:	1.6"	40.6 mm

### HOW TO ORDER

- Specify model, voltage and color
- Optional Accessories:  
Speaker (50GC, page 174)  
Horns (350 and 450, page 124)
- Please refer to Model Number Index VALS beginning on page 372

### REPLACEMENT PARTS

<u>Description</u>	<u>Part Number</u>	<u>Description</u>	<u>Part Number</u>
Lens, Amber	K8435D539A	Lens, Green	K8435D539A-03
Lens, Blue	K8435D539A-08	Lens, Red	K8435D539A-07
Lens, Clear	K8435D539A-02	Strobe Tube	K149128A
		Gasket	K8435A225