



ATEX Audible Visual Sounder

Model WAVS

The flameproof Model WAVS combination alarm sounders and Xenon beacons are suitable for Zone 1 & Zone 2 applications.

Sound level outputs are up to 117dB(A) at 1 meter with a choice of 32 alarm tones and 3 remotely selectable stages.

Sounder & beacon may be connected from a single supply for simultaneous operation or from separate supplies for independent operation.

FEATURES:

- Automatic synchronisation on multi-strobe & sounder systems.
- Beacons can be set to 'flip-flop' alternating mode with other units on multi-strobe systems.
- Xenon tubes mechanically secured against shock & vibration
- Glass lens & Stainless Steel guard
- Very large termination area.
- Ratchet adjustable stainless steel 'U' bracket

ATEX certificate: KEMA 01ATEX2223
 EN 60079-0 : 2006 EN 60079-1 : 2007
 EN 61241-0 : 2006 EN 61241-1 : 2004

IECEX certificate: IECEX KEM 10.0025
 IEC 60079-0 : 2004 (Ed4) IEC 60079-1 : 2007 (Ed6)
 IEC 61241-0 : 2004 (Ed1) IEC 61241-1 : 2004 (Ed1)

- Certificate approvals pending.
 Visit www.federal-signal-indust.com
 for the latest information.

Model	Voltage	Alarm Sounder		Xenon Beacon		
		Voltage Range	Current	Voltage Range	Current	Flash Rate
WAVS-024	24VDC	+/-25%	265mA	20-28V	300mA	60
WAVS-048	48VDC	+/-25%	130mA	42-54V	180mA	60
WAVS-115	115VAC	+/-10%	110mA	+/-10%	140mA	60
WAVS-230	230VAC	+/-10%	56mA	+/-10%	55mA	60



ATEX AUDIBLE VISUAL SOUNDER (WAVS)

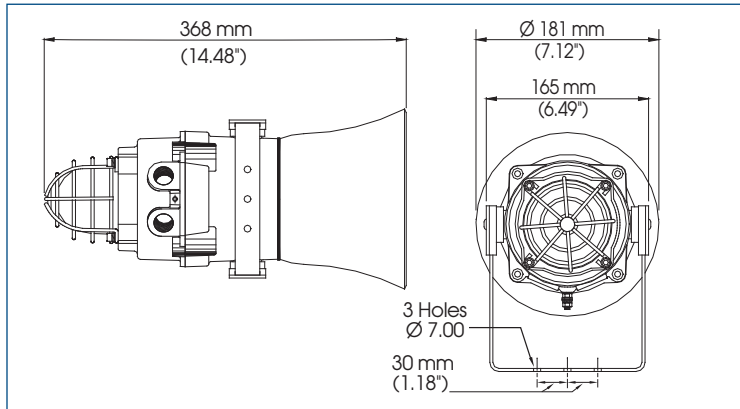

HOW TO ORDER

WAVS - 024 - A

TYPE	VOLTAGE	LENS COLOR
WAVS	024 - 24VDC	A - Amber
ATEX	048 - 48VDC	B - Blue
Audible	115 - 115VAC	C - Clear
Visual	230 - 230VAC	G - Green
Sounder		R - Red
		Y - Yellow

SPECIFICATIONS

ATEX / IECEx: II 2G Ex d IIB T4 Ta. -50° to +70°C
 GOST-R: 1ExdIIBT4 Ta. -50° to +55°C

SOUNDER/HORN:

Maximum output: 117dB(A) @ 1 meter
 Nominal output: 110dB(A) @ 1m +/- 3dB - Tone 2
 No. of tones: 32 (UK00A / PFEER compliant)
 No. of stages: 3
 Volume control: Max. 110dB(A); Min. 72dB(A)-Tone 2
 Voltages DC: 24VDC; 48VDC
 Voltages AC: 115VAC; 230VAC (50Hz/60Hz ±10%)
 Stage switching: Negative or positive

BEACON:

Energy: 5 Joules (5Ws)
 Flash rate: 1Hz (60 fpm)
 Peak Candela: 34,812 cd
 Effective Intensity cd: 54 cd
 Lens colors: Amber, Blue, Clear, Green, Red & Yellow

GENERAL:

Ingress protection: IP66/67
 Housing material: Marine grade copper free LM6 Aluminium
 Housing finish: Phosphated & powder coated
 WAVS flare: High impact UL94 V0 & 5VA FR ABS (Red)
 Cable entries: Dual M20 ISO (one stopping plug included)
 Terminals: 0.5 to 4.0mm² cables.
 Line monitoring : Min. 500 Ohm 2w, or 3k3 Ohm 0.5w res. or diode within Exd enclosure (dc versions).
 Product Weight : DC: 4.00 Kg
 AC: 4.20 Kg
 Shipping Weight : DC: 4.70 Kg
 AC: 4.90 Kg

TONES

Stage 1	Frequency Description	dB @ 1m*	Stage 2	Stage 3
Tone 1	1000 Hz Continuous - PFEER Toxic Gas	110.0dB(A) @ 1m	Tone 31	Tone 11
Tone 2	800/1000Hz @ 0.25 sec Alternating	110.0dB(A) @ 1m	Tone 17	Tone 5
Tone 3	500/1200Hz @ 0.3Hz 0.5 sec Slow Whoop	110.5dB(A) @ 1m	Tone 2	Tone 5
Tone 4	800/1000Hz @ 1Hz Sweeping	110.0dB(A) @ 1m	Tone 6	Tone 5
Tone 5	2400Hz Continuous	109.0dB(A) @ 1m	Tone 3	Tone 27
Tone 6	2400/2900Hz @ 7Hz Sweeping	109.0dB(A) @ 1m	Tone 7	Tone 5
Tone 7	2400/2900Hz @ 1Hz Sweeping	110.0dB(A) @ 1m	Tone 10	Tone 5
Tone 8	500/1200/500Hz @ 0.3Hz Sweeping	110.5dB(A) @ 1m	Tone 2	Tone 5
Tone 9	1200/500Hz @ 1Hz - DIN / PFEER P.T.A.P.	110.5dB(A) @ 1m	Tone 15	Tone 2
Tone 10	2400/2900Hz @ 2Hz Alternating	109.0dB(A) @ 1m	Tone 7	Tone 5
Tone 11	1000Hz @ 0.5Hz Intermittent	110.0dB(A) @ 1m	Tone 31	Tone 1
Tone 12	800/1000Hz @ 0.875Hz Alternating	110.0dB(A) @ 1m	Tone 4	Tone 5
Tone 13	2400Hz @ 1Hz Intermittent	109.0dB(A) @ 1m	Tone 15	Tone 5
Tone 14	800Hz 0.25sec on, 1 sec off Intermittent	103.0dB(A) @ 1m	Tone 4	Tone 5
Tone 15	800Hz Continuous	103.0dB(A) @ 1m	Tone 2	Tone 5
Tone 16	660Hz 150mS on, 150mS off Intermittent	104.0dB(A) @ 1m	Tone 18	Tone 5
	544Hz (100mS)/			
Tone 17	440Hz (400mS) - NF S 32-001	107.0dB(A) @ 1m	Tone 2	Tone 27
Tone 18	660Hz 1.8sec on, 1.8sec off Intermittent	105.0dB(A) @ 1m	Tone 2	Tone 5
	1.4KHz-1.6KHz 1s, 1.6KHz-1.4KHz 0.5s			
Tone 19	-NFC48-265	117.0dB(A) @ 1m	Tone 2	Tone 5
Tone 20	660Hz Continuous	104.0dB(A) @ 1m	Tone 2	Tone 5
Tone 21	554Hz/440Hz @ 1Hz Alternating	107.0dB(A) @ 1m	Tone 2	Tone 5
Tone 22	544Hz @ 0.875 sec. Intermittent	107.0dB(A) @ 1m	Tone 2	Tone 5
Tone 23	800Hz @ 2Hz Intermittent	103.0dB(A) @ 1m	Tone 6	Tone 5
Tone 24	800/1000Hz @ 50Hz Sweeping	107.0dB(A) @ 1m	Tone 29	Tone 5
Tone 25	2400/2900Hz @ 50Hz Sweeping	109.0dB(A) @ 1m	Tone 29	Tone 5
Tone 26	Bell	117.0dB(A) @ 1m	Tone 2	Tone 1
Tone 27	554Hz Continuous	107.0dB(A) @ 1m	Tone 26	Tone 5
Tone 28	440Hz Continuous	104.0dB(A) @ 1m	Tone 2	Tone 5
Tone 29	800/1000Hz @ 7Hz Sweeping	106.0dB(A) @ 1m	Tone 7	Tone 5
	AS2220: 420Hz repeating 0.625 sec on,			
Tone 30	0.625 sec off.	104.0dB(A) @ 1m	Tone 32	Tone 5
Tone 31	660/1200Hz @ 1Hz Sweeping	110.5dB(A) @ 1m	Tone 11	Tone 1
	AS2220: 500-1200Hz 3.75s on 0.25s off			
Tone 32	(15 cycles/min)	110.5dB(A) @ 1m	Tone 26	Tone 1

#259362A Rev A