

ATEX Visual Dual Strobe

Model WVDS



FEATURES:

- Automatic synchronisation on multi-strobe system
- Beacons can be set to 'flip-flop' alternating mode with other units on multi-strobe systems
- Xenon tubes mechanically secured against shock & vibration
- Glass lens & stainless steel guard
- Very large termination area
- Ratchet adjustable stainless steel 'U' bracket

The flameproof Model WVDS dual xenon beacons are suitable for Zone 1, 2, 21 & 22 applications.

With a dual flash energy of 5 Joules (60 fpm) the WVDS units are ideal for general signalling duties while their robust construction makes installation in the harshest of environments possible. The beacons may be connected from a single supply for simultaneous operation or from separate supplies for independent operation.

Additional features include automatic synchronisation on multi-beacon systems and stainless steel guard and mounting bracket as standard.

The WVDS range features enclosures manufactured from corrosion proof, marine grade copper free LM6 aluminium which is phosphated and powder coated. All models have two M20 cable entries, large termination areas and an ingress protection of IP66/67.

APPROVALS:

ATEX certificate: KEMA 01ATEX2222
EN 60079-0 : 2006 EN 60079-1 : 2007
EN 61241-0 : 2006 EN 61241-1 : 2004

IECEX certificate: IECEX KEM 10.0024
IEC 60079-0 : 2004 (Ed4) IEC 60079-1 : 2007 (Ed6)
IEC 61241-0 : 2004 (Ed1) IEC 61241-1 : 2004 (Ed1)

- Certificate approvals pending.
Visit www.federal-signal-indust.com for the latest information.

| Model | Voltage | Voltage Range | Operating Current | Flash Rate/ |
|-----------------|---------|---------------|-------------------|-------------|
| WVDS-024 | 24VDC | 20-24VDC | 270mA | 60 |
| WVDS-048 | 48VDC | 42-54VDC | 180mA | 60 |
| WVDS-115 | 115VAC | 104-126 | 140mA | 60 |
| WVDS-230 | 230VAC | 207-253 | 55mA | 60 |



ATEX VISUAL DUAL STROBE (WVDS)

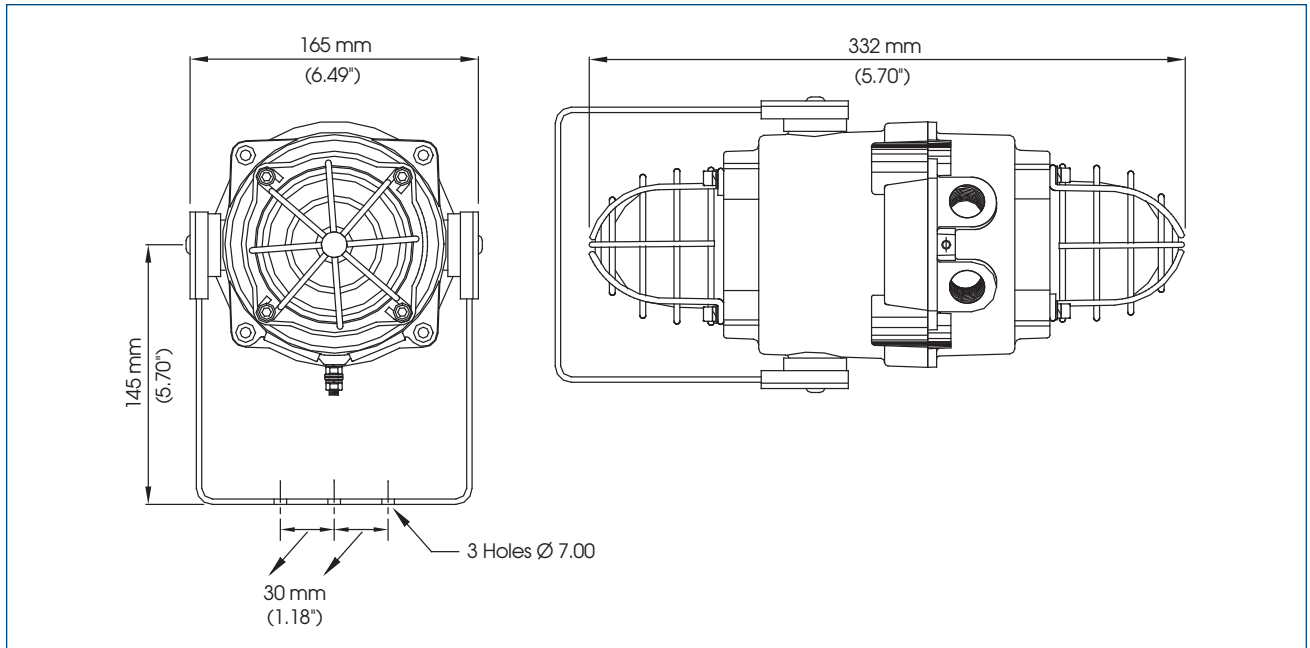

SPECIFICATIONS

ATEX / IECEx:

II 2G Ex d IIC T4 Ta. -50°C to +70°C

II 2G Ex d IIC T5 Ta. -50°C to +55°C

II 2D Ex tD A21 IP67 T115°C

based on max. Ta. of +70°C

Energy: 5 Joules x 2 (5Ws)

Flash rate: 1Hz (60 fpm)

Peak Candela: 34,812 cd x 2

Effective Intensity cd: 54 cd x 2

Lens colors: Amber, Blue, Clear,
Green, Red & Yellow

Voltages DC: 24VDC; 48VDC

Voltages AC: 115VAC; 230VAC (50
Hz / 60Hz ±10%)

Ingress protection: IP66/67

Housing material: Marine grade copper free LM6 Aluminium
Housing finish: Phosphated & powder coated finish - anti-
corrosion

Colour: RAL3000 Red (others available on request)

Cable entries: Dual M20 ISO (one stopping plug included)

Terminals: 0.5 to 4.0mm² cables

Line monitoring : Min. 500 Ohm 2w, or 3k3 Ohm 0.5w res.
or diode within Exd enclosure (dc versions)

Product Weight : DC: 2.95 Kg

AC: 3.00 Kg

Shipping Weight :

DC: 3.70 Kg

AC: 3.75 Kg

HOW TO ORDER

WVDS - 024 - R - A

| TYPE | VOLTAGE | 1st LENS COLOR | 2nd LENS COLOR |
|---|--|----------------|--|
| WVDS ATEX Visual Dual Strobe | 024 - 24VDC 048 - 48VDC 115 - 115VAC 230 - 230VAC | R - Red | A - Amber B - Blue C - Clear G - Green R - Red Y - Yellow |

#259361A Rev A