

SC SERIES DIN RAIL MOUNTING KIT

Part Number(s) 844-001, 844-002, 844-003

Manual Number: IMSDIN03

GENERAL

The SC Series DIN rail mounting kit allows SC Series drives to be mounted to a standard 35mm DIN rail, which simplifies panel layouts and installation. The kit uses mounting brackets that fasten to the DIN rail. The brackets allow for mounting at different heights on the DIN rail so that different size drives may be aligned with the top, bottom, or center of the drives at the same level to suit various wire-routing styles.

Drive Size	Drive Width	DIN Rail Mounting Kit P/N	Bracket Width
A	2.88"	844-001	3.75"
B	3.76"	844-002	4.63"
C	5.02"	844-003	5.89"

There are three different versions of the DIN Rail Mounting Kit (P/N 844-001, 844-002, 844-003). The following table illustrates which kit should be used depending on the size of the drive:

PARTS LIST

Each kit includes the following parts:

- DIN Rail Mounting Brackets (Quantity 6)
- Mounting Screws (Quantity 24)
- Clamping Screws (Quantity 6, except kit version 844-003 has 12 Clamping Screws)

**NOTE:**

The DIN Rail Mounting Brackets in kit version 844-002 can also be used to mount A size drives with 2.88" width.

INSTALLATION

Refer to the drawings on the back of this page during installation.

1. Position the DIN Rail Mounting Bracket onto the DIN rail such that the top edge of the DIN rail fits into the desired slot on the back of the DIN Rail Mounting Bracket. NOTE: The DIN Rail Mounting Bracket has several mounting positions which allow different size drives to be mounted with the top, bottom, or center of the drives at the same level.
2. Screw the Clamping Screw into the hole that matches the selected mounting position. The Clamping Screw should engage the bottom edge of the DIN rail to hold the DIN Rail Mounting Bracket securely in place. NOTE: Kit version 844-003 uses two (2) Clamping Screws.
3. Mount the SC Series drive onto the DIN Rail Mounting Bracket using the four (4) Mounting Screws included with the kit.
4. The tab at the bottom of the DIN Rail Mounting Bracket can be used as an additional mounting point to fasten the DIN Rail Mounting Bracket directly to the back panel. A screw for this is NOT provided in the kit.

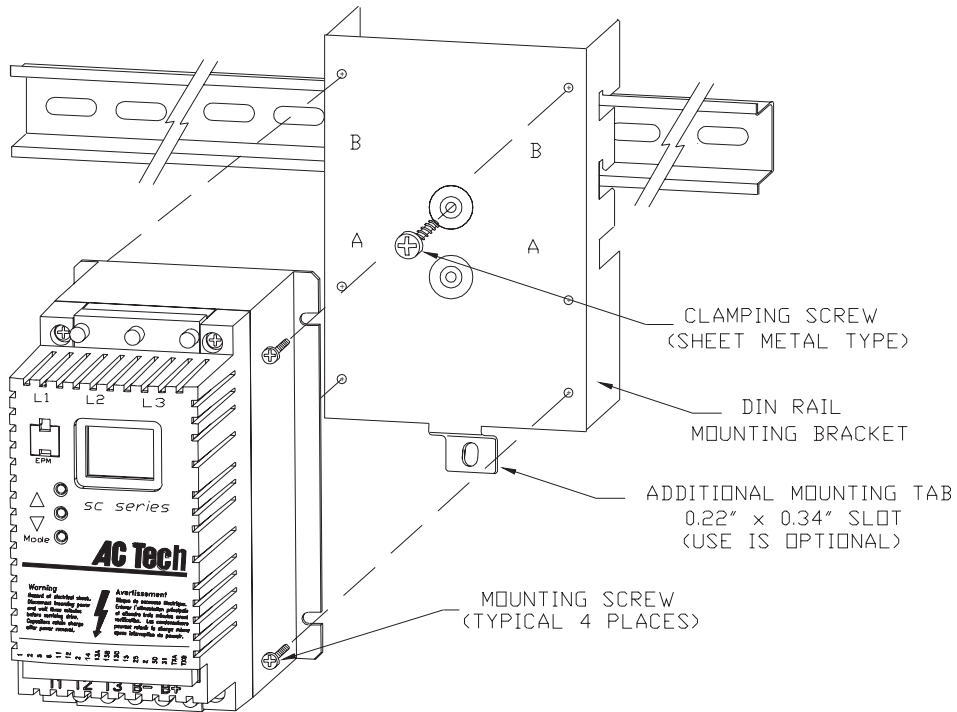

Figure 1: Exploded View

MOUNTING POSITIONS

Figure 2 illustrates the different mounting positions that are possible with the DIN Rail Mounting Kit. Drives can be mounted next to each other with the top, bottom, or center of the drives aligned. The diagrams indicate recommended and alternate mounting positions to use on each DIN Rail Mounting Bracket to achieve the desired alignment.

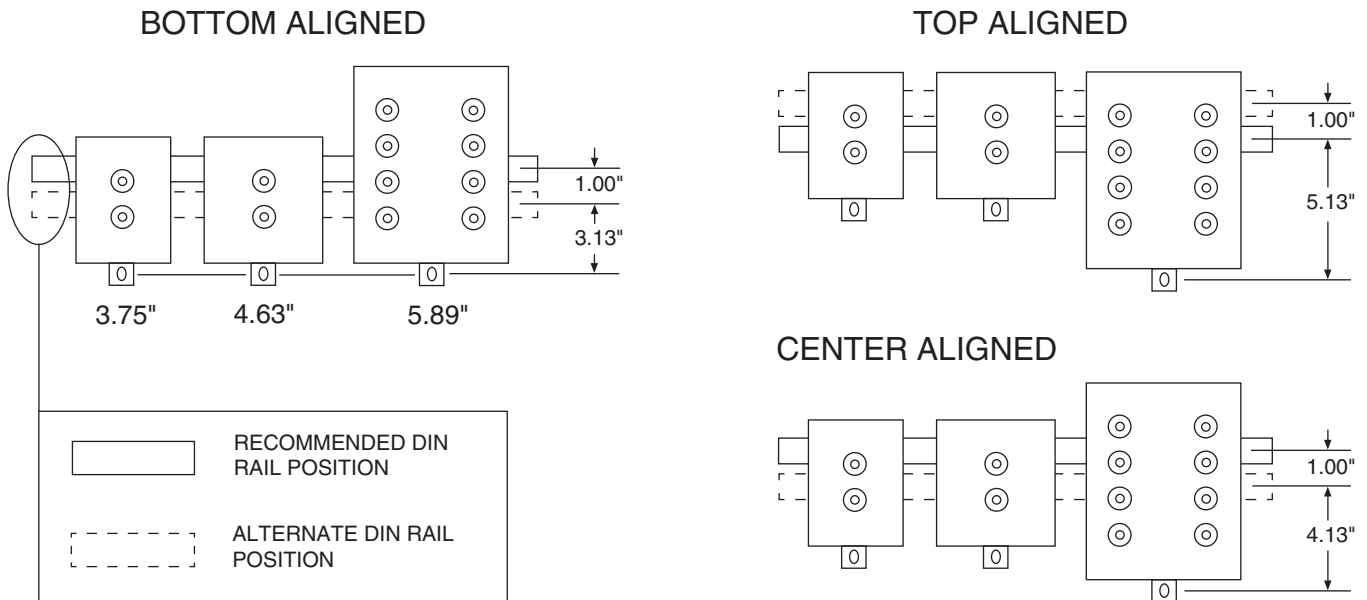

Figure 2: Mounting Positions