



■ Automation Solutions

# Compact Industrial Power Supplies

Compact Industrial Power Supplies  
Current Control System LOCC-Box  
Uninterruptible Power Supply (USP)

**LUTZE** <sup>®</sup>  
Systematic Technology

# Reaching new heights in automation

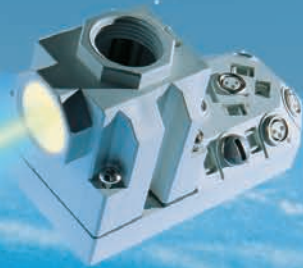

## Contents:

- |                                       |          |
|---------------------------------------|----------|
| 1. Compact Industrial Power Supplies  | P. 6 -38 |
| 2. Current Control System LOCC-Box    | P. 39-50 |
| 3. Uninterruptible Power Supply (USP) | P. 51-68 |



## Installation Solutions



## Cabinet Solutions

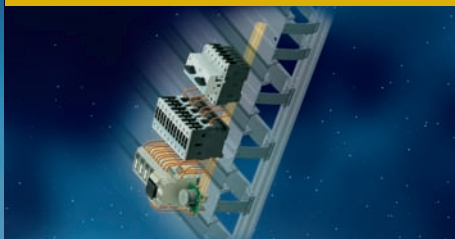

## Automation Solutions



## OEM Solutions



## Transportation Solutions



We have been developing and manufacturing electronic and electrical engineering solutions for controls and installations for more than 50 years.

Our basic concept as system suppliers, providing a comprehensive and well-matched product range with which we can generate innovative and customized solutions for our customers, has stood the test of time.

The close relationship between product development and customer requirements allows Lutze continuously to improve and develop our products for the various markets.

Lutze systems comply with the highest industrial standards; Lutze solutions mean improvement and innovation.

**Our solutions include components and concepts suitable for almost any control application. For more information on our solutions, please visit [www.lutze.com](http://www.lutze.com).**



**Systematic Technology**

# Compact Industrial Power Supplies • Overview



No. 1



No. 2



No. 3



No. 4



No. 5



No. 6

## DC voltage supply, regulated

Rated power											Input			Output					Connection			Part-Nr.	Type	Page	No.		
10 W	15 W	18 W	30 W	50 W	60 W	70 W	93 W	120 W	240 W	480 W	720 W	960 W	1-phase	2-phase	3-phase	5 V	12 V	15 V	24 V	48 V	Screw terminal pluggable					Screw terminal	Spring terminal
•													•				2A					•		728761	DRA10-05A	6	1
•													•				0,84A					•		728766	DRA10-12A	6	1
•													•				2A					•		722761	DRA10-5	7	1
•													•				0,84A					•		722766	DRA10-12	7	1
•													•					0,67A				•		722773	DRA10-15	7	1
•													•					0,42A				•		722751	DRA10-24	7	1
•	•												•				3A					•		722762	DRA18-5	8	1
•	•												•				3A					•		728762	DRA18-5A	8	1
	•												•				1,5A					•		722767	DRA18-12	9	1
	•												•					1,2A				•		722774	DRA18-15	9	1
	•												•						0,75A			•		722752	DRA18-24	9	1
	•	•											•				6A					•		722763	DRA30-5A	10	2
	•	•											•				2,5A					•		722768	DRA30-12A	10	2
	•	•											•					1,25A				•		722753	DRA30-24A	10	2
	•	•											•						0,63A			•		722775	DRA30-48A	10	2
	•	•											•				6A					•		728763	DRA30-5	11	2
	•	•											•				2,5A					•		728768	DRA30-12	11	2
	•	•											•					1,25A				•		728753	DRA30-24	11	2
	•	•											•						0,63A			•		728775	DRA30-48	11	2
	•	•											•						1,2A			•		722790	CPSFB1-30-24	12	3
	•	•											•						1,2A			•		722787	CPSF1-30-24	13	4
	•	•											•				10A					•		722764	DRA60-5A	14	2
	•	•											•				10A					•		728764	DRA60-5	14	2
	•	•											•				5A					•		728769	DRA60-12	15	2
	•	•											•					2,5A				•		728754	DRA60-24	15	2
	•	•											•						1,25A			•		728776	DRA60-48	15	2
	•	•											•				5A					•		722769	DRA60-12A	16	2
	•	•											•					2,5A				•		722754	DRA60-24A	16	2
	•	•											•						1,25A			•		722776	DRA60-48A	16	2
	•	•											•					3,0A				•		722789	CPSF1-70-24	17	4
	•	•											•						3,8A			•		722757	DRAN120-24AL	18	5
	•	•											•				10A					•		722770	DRAN120-12B	19	5
	•	•											•					5A				•		722758	DRAN120-24B	19	5
	•	•											•						2,5A			•		722777	DRAN120-48B	19	5
	•	•											•					5A				•		728758	DRAN120-24A	19	5
	•	•											•					5A				•		722783	CPSB1-120-24R	20	6
	•	•											•						2,5A			•		722784	CPSB1-120-48R	20	6
	•	•											•	•				5A				•		722983	CPSB2-120-24	22	6

# Compact Industrial Power Supplies • Overview



No. 7



No. 8



No. 9



No. 10



No. 11



No. 12

## DC voltage supply, regulated

Rated power										Input			Output					Connection			Part-Nr.	Type	Page	No.							
10 W	15 W	18 W	30 W	50 W	60 W	70 W	93 W	120 W	240 W	480 W	720 W	960 W	1-phase	2-phase	3-phase	5 V	12 V	15 V	24 V	48 V					72 V	Screw terminal pluggable	Screw terminal	Spring terminal			
								•					•							5A			•			722794	CPS65-120-24	21	7		
								•							•					5A				•			722803	WRA 120-24	23	8	
									•											10A				•			722759	DRA240-24B	24	8	
									•												5A				•			722778	DRA240-48B	24	8
									•												10A				•			722781	DRA240-24A	24	8
									•												10A				•			722785	CPSB1-240-24R	25	6
									•												5A				•			722786	CPSB1-240-48R	25	6
									•						•						10A				•			722984	CPSB2-240-24	26	6
									•												10A				•			722799	CPSB3-240-24	27	9
									•												10A				•			722804	WRA240-24	28	8
									•												5A				•			722808	WRA240-48	28	8
									•												20A				•			722782	DRA480-24A	29	10
									•												10A				•			722779	DRA480-48A	29	10
									•												20A				•			722986	CPSB1-480-24R	30	9
									•												10A				•			722989	CPSB1-480-48R	30	9
									•												20A				•			722805	WRA480-24	31	10
									•												10A				•			722809	WRA480-48	31	10
									•												20A				•			722800	CPSB3-500-24	32	9
									•												30A				•			722802	CPSB3-720-24	33	9
									•												15A				•			722807	CPSB3-720-48	33	9
									•												40A				•			722806	WRA960-24	34	11
									•												20A				•			722810	WRA960-48	34	11
									•												40A				•			722811	CPSB3-960-24	35	9
									•												20A				•			722812	CPSB3-960-48	35	9
									•												13,3A				•			722813	CPSB3-960-72	35	9

## DC voltage supply, unregulated

Rated Power							Input			Output					Connection			Part-Nr.	Type	Page	No.	
60 W	72 W	120 W	144 W	240 W	360 W		AC 115 V (104...196 V)	AC 230 V (207...244 V)	AC 400 V (360...424 V)	5 V	12 V	15 V	24 V	48 V	Screw terminal pluggable	Screw terminal	Spring terminal					
•							•	•	•					2,5A		•			722962	NG 24/2,5-2962	37	12
	•						•	•	•					5A		•			722963	NG 24/5-2963	37	12
		•					•	•	•					10A		•			722972	NG24/10-2972	37	12
			•				•	•	•					15A		•			722973	NG24/15-2973	37	12
				•			•	•	•					3,0A		•			722620	NG24/3-2620 SI	38	12
					•		•	•	•					6,0A		•			722621	NG24/6-2621 SI	38	12
						•	•	•	•					10A		•			722622	NG24/10-2622 SI	38	12

## Redundant Manager

Current	Input/Output	Monitoring			Output	Connection			Part-Nr.	Type	Page	No.
		Under Voltage	Over Voltage	Potential free Status Output		Screw terminal pluggable	Screw terminal	Spring terminal				
•	DC 24 V (21...28 V)	•	•	•	20A		•		722962	DRP 20-24	36	2

# Power supply · regulated, 10 W

## Primary switchmode power supply, Single-phase, Class 2

Input: Wide range input AC 90 V - 265 V; DC 120 V - 370 V

Output: 5 V / 12 V - adjustable



### Dimensions

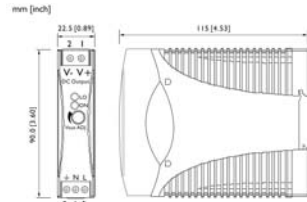

### PIN assignment

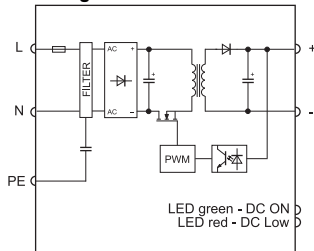

### Derating

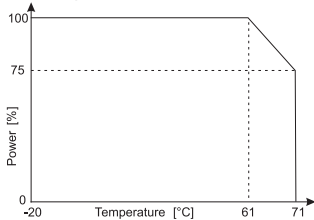

### Redundant operation

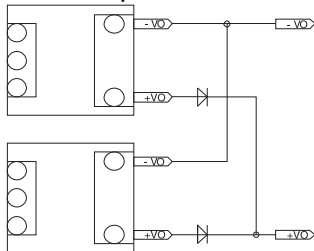

Description	Part-No.	Type	PU
<b>Screw terminal</b>			
Output voltage/current	DC 5 V; 2 A	728761	DRA 10-05A
	DC 12 V; 0.84 A	728766	DRA 10-12A

Input	DRA 10-05A	DRA 10-12A
Nominal voltage	AC 100–240 V	
Operation voltage range	AC 90–265 V / DC 120–370 V	
Line frequency	47 – 63 Hz	
Rated current	U <sub>i</sub> = AC 115 V: 120 mA / U <sub>i</sub> = AC 230 V: 70 mA	
Inrush current	U <sub>i</sub> = AC 115 V: 10 A / U <sub>i</sub> = AC 230 V: 18 A	
Internal fuse	T2 A / AC 250 V	
External fuse	Mini-circuit breaker: B 4 A	
Power Factor Correction P.F.C.	–	

Output	DRA 10-05A	DRA 10-12A
Rated voltage output	DC 5 V	DC 12 V
Rated current output	2 A	0.84 A
Max. output current	–	
Short-circuit current	–	
Voltage trim range	4.5–5.75 V	10.8–13.8 V
Accuracy	±1 %	
Line regulation	±1 %	
Load regulation	±2 %	
Rise time	1 s	
Temperature coefficient	±0.03 % / °C	
Ripple & Noise	<50 mV	
Hold up time	V <sub>in</sub> = 115 V: 25 ms / V <sub>in</sub> = 230 V: 100 ms	
Status indication DC ON LED green	≥4.5 V	≥10.8 V
Status indication DC LOW LED red	<3.75–4.50 V	<9–10.8 V
Parallel/redundant operation	max. 2 devices / via external diodes	
Efficiency	73 %	75 %
Low power loss	4 A (AC 230 V)	3.4 A (AC 230 V)
Rated over load protection	110–135 %	
Over voltage protection	125–145 %	
Short circuit characteristics	Hiccup-mode	

General		
Switching frequency	approx. 100 kHz	
Insulation voltage input/output	AC 3.0 kV <sub>eff</sub>	
Insulation voltage input / ground	AC 1.5 kV <sub>eff</sub>	
Insulation voltage output / ground	–	
Insulation resistance at DC 500 V	100 MΩ	
Operation temperature range	-20 °C – 70 °C (derating)	
Derating	-3% / °C starting at 61° C	
Storage temperature range	-25 °C – 85 °C	
M.T.B.F.	801000 h	803000 h

Relative humidity	20–95% RH, non-condensing	
Dimensions (w × h × d) in mm	22.5 × 90.0 × 115.0	
Cooling	Natural air cooling, 25 mm distance on all sides	
Housing material	Plastic	
Field installation	rail TS 35 (EN 50022)	
Application height	2000 m	
Installation position	vertical	
Protection class	IP 20	
IP rating	II (SELV, PELV)	
Overvoltage category	II	
Pollution degree	2	
Weight (kg/piece)	0.120	
Termination	Screw terminal: 0.2–2.5 mm <sup>2</sup> , max. 0.56 Nm	
Approvals	UL: UL 508 listed; cUL: UL 60950-1, UL 1310 Class 2; TÜV: EN 60950-1, CE: EN 50081-1 / EN 55022 Class B, EN 61000-3-2, EN 601000-3-3, EN 50082-1 / EN 55024	

Monitoring	
DC ON Control (Rdy)	LED green/red
Switching voltage	–
Switching current	–
Switching capacity	–
Insulation voltage	–

# Power supply - regulated, 10 W

**Primary switchmode power supply, Single-phase, Class 2**  
**Input: Wide range input AC 90 V - 265 V; DC 120 V - 370 V**  
**Output: 5 V / 12 V / 15 V / 24 V - adjustable**



## Dimensions

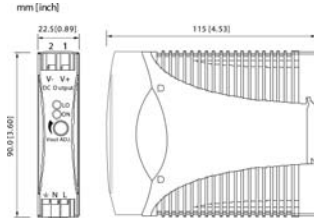

## PIN assignment

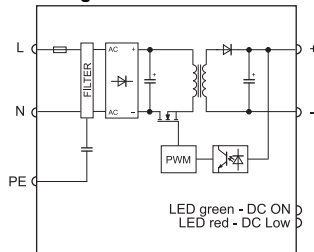

## Derating

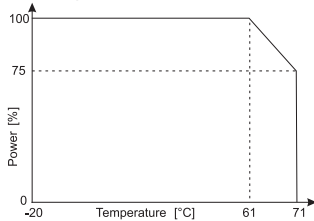

## Redundant operation

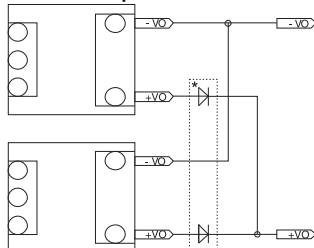

\* Redundant Module 722987  
 Only use together with 24V version!

Description	Part-No.	Type	PU	
<b>Spring terminal</b>				
Output voltage/current	DC 5 V; 2 A	722761	DRA 10-05	1
	DC 12 V; 0.84 A	722766	DRA 10-12	1
	DC 15 V; 0.67 A	722773	DRA 10-15	1
	DC 24 V; 0.42 A	722751	DRA 10-24	1

Input	DRA 10-05	DRA 10-12	DRA 10-15	DRA 10-24
Nominal voltage	AC 100–240 V			
Operation voltage range	AC 90–265 V / DC 120–370 V			
Line frequency	47 – 63 Hz			
Rated current	U <sub>i</sub> = AC 115 V: 120 mA / U <sub>i</sub> = AC 230 V: 70 mA			
Inrush current	U <sub>i</sub> = AC 115 V: 10 A / U <sub>i</sub> = AC 230 V: 18 A			
Internal fuse	T2 A / AC 250 V			
External fuse	Mini-circuit breaker: B 4 A			
Power Factor Correction P.F.C.	–			
<b>Output</b>				
Rated voltage output	DC 5 V	DC 12 V	DC 15 V	DC 24 V
Rated current output	2 A	0.84 A	0.67 A	0.42 A
Max. output current	–			
Short-circuit current	–			
Voltage trim range	4.5–5.75 V	10.8–13.8 V	13.5–17.25 V	21.6–28.8 V
Accuracy	±1 %			
Line regulation	±1 %			
Load regulation	±2 %			
Rise time	1 s			
Temperature coefficient	±0.03 % / °C			
Ripple & Noise	<50 mV			
Hold up time	V <sub>in</sub> = 115 V: 25 ms / V <sub>in</sub> = 230 V: 100 ms			
Status indication DC ON LED green	≥4.5 V	≥10.8 V	≥13.5 V	≥21.6 V
Status indication DC LOW LED red	<3.75–4.50 V	<9–10.8 V	<11.25–13.5 V	<18–21.6 V
Parallel/redundant operation	max. 2 devices / via external diodes			
Efficiency	73 %	75 %	76 %	77 %
Low power loss	4 A (AC 230 V)	3.4 A (AC 230 V)	3.3 A (AC 230 V)	2.8 A (AC 230 V)
Rated over load protection	110–135 %			
Over voltage protection	125–145 %			
Short circuit characteristics	Hiccup-mode			
<b>General</b>				
Switching frequency	approx. 100 kHz			
Insulation voltage input/output	AC 3.0 kV <sub>eff</sub>			
Insulation voltage input / ground	AC 1.5 kV <sub>eff</sub>			
Insulation voltage output / ground	–			
Insulation resistance at DC 500 V	100 MΩ			
Operation temperature range	–20 °C – 70 °C (derating)			
Derating	–3% / °C starting at 61 °C			
Storage temperature range	–25 °C – 85 °C			
M.T.B.F.	801000 h	803000 h	805000 h	808000 h
Relative humidity	20–95% RH, non-condensing			
Dimensions (w × h × d) in mm	22.5 × 90.0 × 115.0			
Cooling	Natural air cooling, 25 mm distance on all sides			
Housing material	Plastic			
Field installation	rail TS 35 (EN 50022)			
Application height	2000 m			
Installation position	vertical			
Protection class	IP 20			
IP rating	II (SELV, PELV)			
Overvoltage category	II			
Pollution degree	2			
Weight (kg/piece)	0.120			
Termination	Spring terminal: 0.2–2.0 mm <sup>2</sup>			
Approvals	UL: UL 508 listed; cUL: UL 60950-1, UL 1310 Class 2; TÜV: EN 60950-1, CE: EN 50081-1 / EN 55022 Class B, EN 61000-3-2, EN 61000-3-3, EN 50082-1 / EN 55024			

<b>Monitoring</b>	
DC ON Control (Rdy)	LED green/red
Switching voltage	–
Switching current	–
Switching capacity	–
Insulation voltage	–

# Power supply · regulated, 15 W

**Primary switchmode power supply, Single-phase, Class 2**  
**Input: Wide range input AC 90 V - 265 V; DC 120 V - 370 V**  
**Output: 5 V - adjustable**



## Dimensions

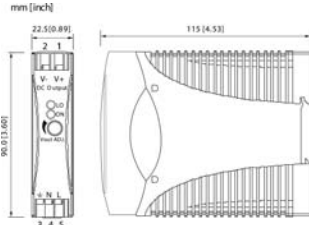

## PIN assignment

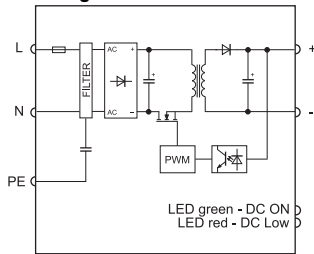

## Derating

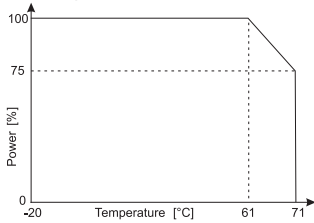

## Redundant operation

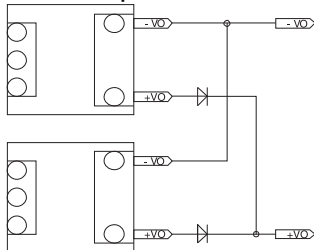

Description	Part-No.	Type	PU	
<b>Screw terminal</b>				
Output voltage/current	DC 5 V; 3 A	728762	DRA 18-05A	1
<b>Spring terminal</b>				
Output voltage/current	DC 5 V; 3 A	722762	DRA 18-05	1
<b>Input</b>		<b>DRA 18-05A</b>	<b>DRA 18-05</b>	
Nominal voltage		AC 100–240 V		
Operation voltage range		AC 90–265 V / DC 120–370 V		
Line frequency		47 – 63 Hz		
Rated current		U <sub>I</sub> = AC 115 V: 170 mA / U <sub>I</sub> = AC 230 V: 90 mA		
Inrush current		U <sub>I</sub> = AC 115 V: 10 A / U <sub>I</sub> = AC 230 V :18 A		
Internal fuse		T2 A / AC 250 V		
External fuse		Mini-circuit breaker: B 4 A		
Power Factor Correction P.F.C.		–		
<b>Output</b>				
Rated voltage output		DC 5 V		
Rated current output		3 A		
Max. output current		–		
Short-circuit current		–		
Voltage trim range		4.5–5.75 V		
Accuracy		±1 %		
Line regulation		±1 %		
Load regulation		±2 %		
Rise time		1 s		
Temperature coefficient		±0.03 % / °C		
Ripple & Noise		<50 mV		
Hold up time		U <sub>I</sub> = 115 V: 20 ms / U <sub>I</sub> = 230 V: 75 ms		
Status indication DC ON LED green		≥4.5 V		
Status indication DC LOW LED red		<3.75–4.50 V		
Parallel/redundant operation		max. 2 devices / via external diodes		
Efficiency		75 %		
Low power loss		5 A (AC 230 V)		
Rated over load protection		110–135 %		
Over voltage protection		125–145 %		
Short circuit characteristics		Hiccup-mode		
<b>General</b>				
Switching frequency		approx. 100 kHz		
Insulation voltage input/output		AC 3.0 kV <sub>eff</sub>		
Insulation voltage input / ground		AC 1.5 kV <sub>eff</sub>		
Insulation voltage output / ground		–		
Insulation resistance at DC 500 V		100 MΩ		
Operation temperature range		-20 °C – 70 °C (derating)		
Derating		-3% / °C starting at 60 °C		
Storage temperature range		-25 °C – 85 °C		
M.T.B.F.		795000 h		
Relative humidity		20–95% RH, non-condensing		
Dimensions (w × h × d) in mm		22.5 × 90.0 × 115.0		
Cooling		Natural air cooling, 25 mm distance on all sides		
Housing material		Plastic		
Field installation		rail TS 35 (EN 50022)		
Application height		2000 m		
Installation position		vertical		
Protection class		IP 20		
IP rating		II (SELV, PELV)		
Overvoltage category		II		
Pollution degree		2		
Weight (kg/piece)		0.150		
Termination		Screw terminal: 0.2–2.5 mm <sup>2</sup> , max. 0.56 Nm		Spring terminal: 0.2–2.0 mm <sup>2</sup>
Approvals		UL: UL 508 listed; cUL: UL 60950-1, UL 1310 Class 2; TÜV: EN 60950-1, CE: EN 50081-1 / EN 55022 Class B, EN 61000-3-2, EN 601000-3-3, EN 50082-1 / EN 55024		
<b>Monitoring</b>				
DC ON Control (Rdy)		LED green/red		
Switching voltage		–		
Switching current		–		
Switching capacity		–		
Insulation voltage		–		



# Power supply - regulated, 18 W

**Primary switchmode power supply, Single-phase, Class 2**  
**Input: Wide range input AC 90 V - 265 V; DC 120 V - 370 V**  
**Output: 12 V / 15 V / 24 V - adjustable**



## Dimensions

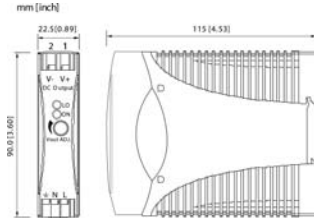

## PIN assignment

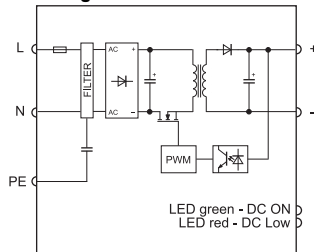

## Derating

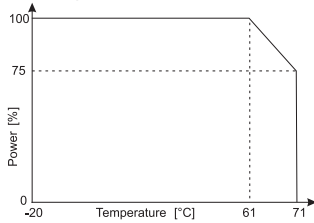

## Redundant operation

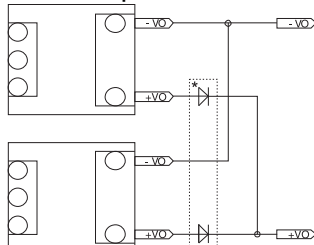

\* Redundant Module 722987  
 Only use together with 24V version!

Description	Part-No.	Type	PU	
<b>Spring terminal</b>				
Output voltage/current	DC 12 V; 1.5 A	722767	DRA 18-12	1
	DC 15 V; 1.2 A	722774	DRA 18-15	1
	DC 24 V; 0.75 A	722752	DRA 18-24	1
<b>Input</b>				
	<b>DRA 18-12</b>	<b>DRA 18-15</b>	<b>DRA 18-24</b>	
Nominal voltage		AC 100–240 V		
Operation voltage range	AC 90–265 V / DC 120–370 V			
Line frequency	47 – 63 Hz			
Rated current	U <sub>I</sub> = AC 115 V: 200 mA / U <sub>I</sub> = AC 230 V: 110 mA			
Inrush current	U <sub>I</sub> = AC 115 V: 10 A / U <sub>I</sub> = AC 230 V: 18 A			
Internal fuse	T2 A / AC 250 V			
External fuse	Mini-circuit breaker: B 4 A			
Power Factor Correction P.F.C.	–			
<b>Output</b>				
Rated voltage output	DC 12 V	DC 15 V	DC 24 V	
Rated current output	1.5 A	1.2 A	0.75 A	
Max. output current	–			
Short-circuit current	–			
Voltage trim range	10.8–13.8 V	13.5–17.25 V	21.6–28.8 V	
Accuracy	±1 %			
Line regulation	±1 %			
Load regulation	±2 %			
Rise time	1 s			
Temperature coefficient	±0.03 % / °C			
Ripple & Noise	<50 mV			
Hold up time	U <sub>I</sub> = 115 V: 20 ms / U <sub>I</sub> = 230 V: 75 ms			
Status indication DC ON LED green	≥10.8 V	≥13.5 V	≥21.6 V	
Status indication DC LOW LED red	<9–10.8 V	<11.25–13.5 V	<18–21.6 V	
Parallel/redundant operation	max. 2 devices / via external diodes			
Efficiency	77 %			
Low power loss	4.65 A (AC 230 V)	4.25 A (AC 230 V)	4.45 A (AC 230 V)	
Rated over load protection	110–135 %			
Over voltage protection	125–145 %			
Short circuit characteristics	Hiccup-mode			
<b>General</b>				
Switching frequency	approx. 100 kHz			
Insulation voltage input/output	AC 3.0 kV <sub>eff</sub>			
Insulation voltage input / ground	AC 1.5 kV <sub>eff</sub>			
Insulation voltage output / ground	–			
Insulation resistance at DC 500 V	100 MΩ			
Operation temperature range	-20 °C – 70 °C (derating)			
Derating	-3% / °C starting at 60 °C			
Storage temperature range	-25 °C – 85 °C			
M.T.B.F.	797000 h	796000 h	800000 h	
Relative humidity	20–95% RH, non-condensing			
Dimensions (w × h × d) in mm	22.5 × 90.0 × 115.0			
Cooling	Natural air cooling, 25 mm distance on all sides			
Housing material	Plastic			
Field installation	rail TS 35 (EN 50022)			
Application height	2000 m			
Installation position	vertical			
Protection class	IP 20			
IP rating	II (SELV, PELV)			
Overvoltage category	II			
Pollution degree	2			
Weight (kg/piece)	0.150			
Termination	Spring terminal: 0.2–2.0 mm <sup>2</sup>			
Approvals	UL: UL 508 listed; cUL: UL 60950-1, UL 1310 Class 2; TÜV: EN 60950-1, CE: EN 50081-1 / EN 55022 Class B, EN 61000-3-2, EN 61000-3-3, EN 50082-1 / EN 55024			
<b>Monitoring</b>				
DC ON Control (Rdy)	LED green/red			
Switching voltage	–			
Switching current	–			
Switching capacity	–			
Insulation voltage	–			

# Power supply · regulated, 30 W

## Primary switchmode power supply, Single-phase, Class 2

Input: Wide range input AC 85 V - 264 V; DC 90 V - 375 V

Output: 5 V / 12 V / 24 V / 48 V - adjustable



### Dimensions

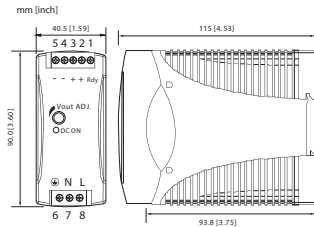

### PIN assignment

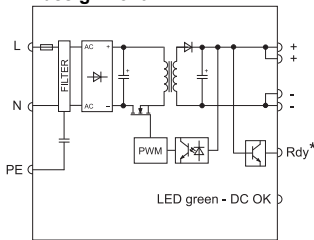

\* for 24V version only

### Derating

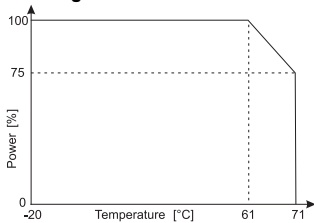

### Redundant operation

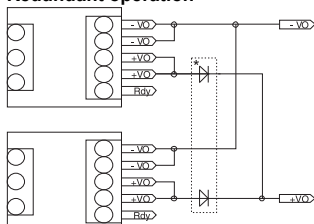

\* Redundant Module 722987  
Only use together with 24V version!

Description	Part-No.	Type	PU	
<b>Screw terminal</b>				
Output voltage/current	DC 5 V; 6 A	722763	DRA 30-05A	1
	DC 12 V; 2.5 A	722768	DRA 30-12A	1
	DC 24 V; 1.25 A	722753	DRA 30-24A	1
	DC 48 V; 0.625 A	722775	DRA 30-48A	1

Input	DRA 30-05A	DRA 30-12A	DRA 30-24A	DRA 30-48A
Nominal voltage	AC 100–240 V			
Operation voltage range	AC 85–264 V / DC 90–375 V			
Line frequency	47 – 63 Hz			
Rated current	U <sub>i</sub> = AC 115 V: 360 mA / U <sub>i</sub> = AC 230 V: 190 mA			
Inrush current	U <sub>i</sub> = AC 115 V: 20 A / U <sub>i</sub> = AC 230 V: 40 A			
Internal fuse	T2 A / AC 250 V			
External fuse	Mini-circuit breaker: B 4 A			
Power Factor Correction P.F.C.	–			

Output	DRA 30-05A	DRA 30-12A	DRA 30-24A	DRA 30-48A
Rated voltage output	DC 5 V	DC 12 V	DC 24 V	DC 48 V
Rated current output	6 A	2.5 A	1.25 A	0.625
Max. output current	–			
Short-circuit current	–			
Voltage trim range	5–5.5 V	12/14 V	24/28 V	48/55 V
Accuracy	±1 %			
Line regulation	±0.5 %			
Load regulation	±0.5 %			
Rise time	1 s			
Temperature coefficient	±0.03 % / °C			
Ripple & Noise	<50 mV			
Hold up time	V <sub>in</sub> = 115 V: 20 ms / V <sub>in</sub> = 230 V: 30 ms			
Status indication DC ON LED green	≥4 V	≥9.6 V	≥19.2 V	≥37 V
Status indication DC LOW LED red	–			
Parallel/redundant operation	max. 2 devices / via external diodes			
Efficiency	79 %	84 %	86 %	
Low power loss	8.5 A (AC 230 V)	5.6 A (AC 230 V)	5.5 A (AC 230 V)	4.9 A (AC 230 V)
Rated over load protection	120 – 136 %		110 – 140 %	
Over voltage protection	125–137 %			
Short circuit characteristics	Hiccup-mode			

General				
Switching frequency	approx. 80 kHz			
Insulation voltage input/output	AC 3.0 kV <sub>eff</sub>			
Insulation voltage input / ground	AC 1.5 kV <sub>eff</sub>			
Insulation voltage output / ground	–			
Insulation resistance at DC 500 V	100 MΩ			
Operation temperature range	–25 °C – 70 °C (derating)			
Derating	–2.5 % / °C starting at 60 °C			
Storage temperature range	–25 °C – 85 °C			
M.T.B.F.	551000 h	582000 h	588000 h	609000 h
Relative humidity	20–90% RH, non-condensing			
Dimensions (w × h × d) in mm	40.5 × 90.0 × 115.0			
Cooling	Natural air cooling, 25 mm distance on all sides			
Housing material	Plastic			
Field installation	rail TS 35 (EN 50022)			
Application height	2000 m			
Installation position	vertical			
Protection class	IP 20			
IP rating	II (SELV, PELV)			
Overvoltage category	II			
Pollution degree	2			
Weight (kg/piece)	0.290			
Termination	Screw terminal: 0.2–2.5 mm <sup>2</sup> , max. 0.56 Nm			
Approvals	UL: UL 508 listed; cUL: UL 60950-1, UL 1310 Class 2; TÜV: EN 60950-1, CE: EN 61000-6-3 / EN 55022 Class B, EN 61000-3-2, EN 601000-3-3, EN 55024, EN 61000-6-2, EN 61000-4-2, EN 61000-4-3, EN 61000-4-4, EN 61000-4-5, EN 61000-4-6, EN 61000-4-8, EN 61000-4-11			

Monitoring				
DC ON Control (Rdy)	–	Open Collector		–
Switching voltage	–	DC 24 V		–
Switching current	–	≤ 35 mA		–
Switching capacity	–	–		–
Insulation voltage	–	none		–

# Power supply - regulated, 30 W

## Primary switchmode power supply, Single-phase, Class 2

Input: Wide range input AC 85 V - 264 V; DC 90 V - 375 V

Output: 5 V / 12 V / 24 V / 48 V - adjustable



### Dimensions

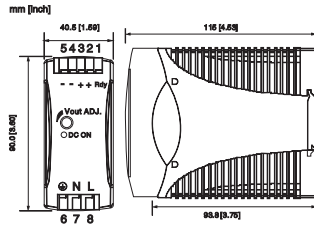

### PIN assignment

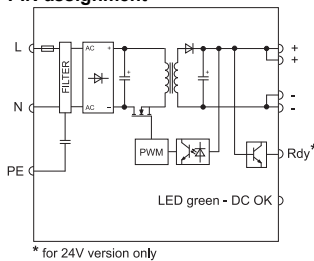

### Derating

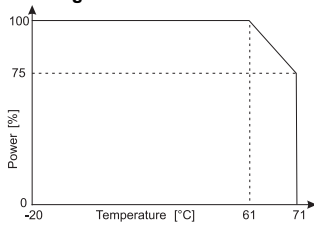

### Redundant operation

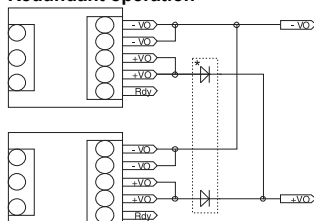

\* Redundant Module 722987  
Only use together with 24V version!

Description	Part-No.	Type	PU	
<b>Spring terminal</b>				
Output voltage/current	DC 5 V; 6 A	728763	DRA 30-05	1
	DC 12 V; 2.5 A	728768	DRA 30-12	1
	DC 24 V; 1.25 A	728753	DRA 30-24	1
	DC 48 V; 0.625 A	728775	DRA 30-48	1

Input	DRA 30-05	DRA 30-12	DRA 30-24	DRA 30-48
Nominal voltage	AC 100–240 V			
Operation voltage range	AC 85–264 V / DC 90–375 V			
Line frequency	47 – 63 Hz			
Rated current	U <sub>i</sub> = AC 115 V: 360 mA / U <sub>i</sub> = AC 230 V: 190 mA			
Inrush current	U <sub>i</sub> = AC 115 V: 20 A / U <sub>i</sub> = AC 230 V: 40 A			
Internal fuse	T2 A / AC 250 V			
External fuse	Mini-circuit breaker: B 4 A			
Power Factor Correction P.F.C.	–			
<b>Output</b>				
Rated voltage output	DC 5 V	DC 12 V	DC 24 V	DC 48 V
Rated current output	6 A	2.5 A	1.25 A	0.625
Max. output current	–			
Short-circuit current	–			
Voltage trim range	5–5.5 V	12/14 V	24/28 V	48/55 V
Accuracy	±1 %			
Line regulation	±0.5 %			
Load regulation	±0.5 %			
Rise time	1 s			
Temperature coefficient	±0.03 % / °C			
Ripple & Noise	<50 mV			
Hold up time	V <sub>in</sub> = 115 V: 20 ms / V <sub>in</sub> = 230 V: 30 ms			
Status indication DC ON LED green	≥4 V	≥9.6 V	≥19.2 V	≥37 V
Status indication DC LOW LED red	–			
Parallel/redundant operation	max. 2 devices / via external diodes			
Efficiency	79 %	84 %	86 %	
Low power loss	8.5 A (AC 230 V)	5.6 A (AC 230 V)	5.5 A (AC 230 V)	4.9 A (AC 230 V)
Rated over load protection	110–140 %			
Over voltage protection	120–136 %		125–137 %	
Short circuit characteristics	Hiccup-mode			
<b>General</b>				
Switching frequency	approx. 80 kHz			
Insulation voltage input/output	AC 3.0 kV <sub>eff</sub>			
Insulation voltage input / ground	AC 1.5 kV <sub>eff</sub>			
Insulation voltage output / ground	–			
Insulation resistance at DC 500 V	100 MΩ			
Operation temperature range	–25 °C – 70 °C (derating)			
Derating	–2.5% / °C starting at 60 °C			
Storage temperature range	–25 °C – 85 °C			
M.T.B.F.	551000 h	582000 h	588000 h	609000 h
Relative humidity	20–90% RH, non-condensing			
Dimensions (w × h × d) in mm	40.5 × 90.0 × 115.0			
Cooling	Natural air cooling, 25 mm distance on all sides			
Housing material	Plastic			
Field installation	rail TS 35 (EN 50022)			
Application height	2000 m			
Installation position	vertical			
Protection class	IP 20			
IP rating	II (SELV, PELV)			
Overvoltage category	II			
Pollution degree	2			
Weight (kg/piece)	0.290			
Termination	Spring terminal: 0.2–2.0 mm <sup>2</sup>			
Approvals	UL: UL 508 listed; cUL: UL 60950-1; TÜV: EN 60950-1, CE: EN 61000-6-3 / EN 55022 Class B; EN 61000-3-2, EN 601000-3-3; EN 55024; EN 61000-6-2; EN 61000-4-2; EN 61000-4-3, EN 61000-4-4; EN 61000-4-5; EN 61000-4-6; EN 61000-4-8; EN 61000-4-11			
<b>Monitoring</b>				
DC ON Control (Rdy)	–	Open Collector		–
Switching voltage	–	DC 24 V		–
Switching current	–	≤ 35 mA		–
Switching capacity	–			
Insulation voltage	–	none		–

# Power supply · regulated, 30 W

## Primary switchmode power supply, PFC, Single-phase, Class 2

Input: Wide range input AC 90 V - 264 V; DC 100 V - 320 V

Output: DC 24 V



### Dimensions

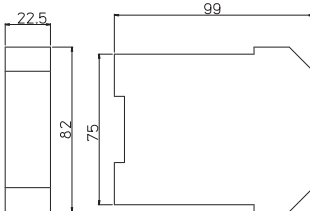

### PIN assignment

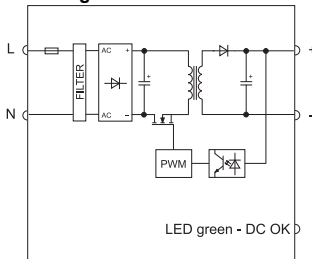

### Derating

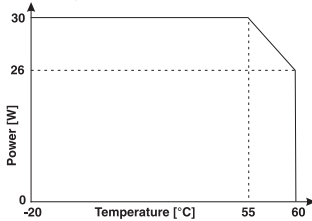

### Redundant operation

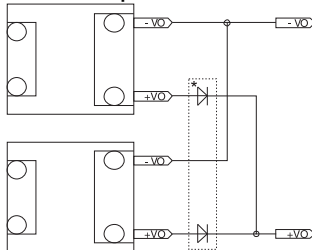

\* Redundant Module 722987

Description	Part-No.	Type	PU
<b>Screw terminal</b>			
Output voltage/current	DC 24 V; 1.2 A	722790	CPSFB1-30-24
			1
<b>Input</b>			
<b>CPSFB1-30-24</b>			
Nominal voltage	AC 120 V / 230 V		
Operation voltage range	AC 90–264 V / DC 100–320 V		
Line frequency	47 – 63 Hz		
Rated current	U <sub>i</sub> = AC 120 V: 0.55 A / U <sub>i</sub> = AC 240 V: 0.30 A		
Inrush current	<AC 25 A		
Internal fuse	T 1.25 A / AC 250 V		
External fuse	Mini-circuit breaker: C 2 A		
Power Factor Correction P.F.C.	>0.6		
<b>Output</b>			
Rated voltage output	DC 24 V		
Rated current output	1.2 A		
Max. output current	1.4 A @ 24 V		
Short-circuit current	10 A, 50 ms		
Voltage trim range	–		
Accuracy	±1%		
Line regulation	–		
Load regulation	<1 %		
Rise time	–		
Temperature coefficient	–		
Ripple & Noise	<80 mV pp		
Hold up time	>10 ms (AC 120 V); >30 ms (AC 240 V)		
Status indication DC ON LED green	yes		
Status indication DC LOW LED red	No		
Parallel/redundant operation	max. 2 devices / via external diodes		
Efficiency	>86 % (AC 120 V); > 87 % (AC 240 V)		
Low power loss	<4.7 W (AC 120 V); <4.3 W (AC 240 V)		
Rated over load protection	yes		
Over voltage protection	yes		
Short circuit characteristics	Hiccup-mode		
<b>General</b>			
Switching frequency	approx. 70 – 110 kHz		
Insulation voltage input/output	AC 3.0 kV <sub>eff</sub>		
Insulation voltage input / ground	class 2, without PE		
Insulation voltage output / ground	class 2, without PE		
Insulation resistance at DC 500 V	– MΩ		
Operation temperature range	–20 °C – 60 °C (derating) (50°C UL508)		
Derating	>55°C: -0.8 W / °C		
Storage temperature range	–25 °C – 85 °C		
M.T.B.F.	750000 h to SN29500 / 250000 h to MIL Standard HDBK 217F		
Relative humidity	20–90% RH, non-condensing		
Dimensions (w × h × d) in mm	22.5 × 82.0 × 99.0		
Cooling	Natural air cooling, 10 mm distance right/left, 20 mm distance above/below		
Housing material	Noryl UL 94-0		
Field installation	rail TS 35 (EN 50022)		
Application height	– m		
Installation position	vertical		
Protection class	IP 20 (IEC529, EN60529)		
IP rating	II (SELV, PELV)		
Overvoltage category	II		
Pollution degree	2		
Weight (kg/piece)	0.140		
Termination	Screw terminal: 0.2–2.5 mm <sup>2</sup> , max. 0.56 Nm		
Approvals	UL, cUL: UL 508, IEC 950, EN 60950, UL 60950 CE: EN 61000-4-2/3/4/5/6/11, EN 61000-6-2, EN 61000-6-4, EN 50178, EN 61558, EN 61000-3-2, EN 50081-1, EN 50082-2, EN 55022 Class B, EN 55011B		
<b>Monitoring</b>			
DC ON Control (Rdy)	–		
Switching voltage	–		
Switching current	–		
Switching capacity	–		
Insulation voltage	–		

# Power supply - regulated, 30 W

**Primary switchmode power supply, PFC, Single-phase, Class 2**  
**Input: Wide range input AC 90 V - 264 V; DC 110 V - 370 V**  
**Output: DC 24 V**



## Dimensions

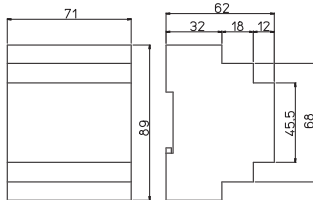

## PIN assignment

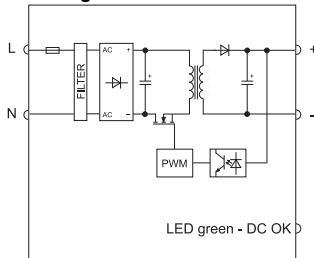

## Derating

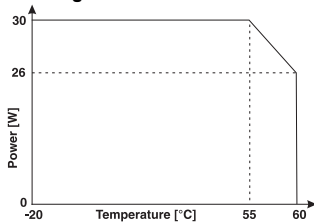

## Redundant operation

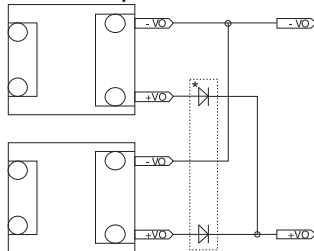

\* Redundant Module 722987

Description	Part-No.	Type	PU
<b>Screw terminal</b>			
Output voltage/current	DC 24 V; 1.2 A	722787	CPSF1-30-24
			1
<b>Input</b>		<b>CPSF1-30-24</b>	
Nominal voltage	AC 115 / 230 V		
Operation voltage range	AC 90–264 V / DC 110–370 V (DC 300 V; UL508)		
Line frequency	47 – 63 Hz		
Rated current	U <sub>i</sub> = AC 100 V: 0.65 A / U <sub>i</sub> = AC 240 V: 0.30 A		
Inrush current	<AC 13 A		
Internal fuse	T2 A / AC 250 V		
External fuse	Mini-circuit breaker: B 4 A, C 2 A		
Power Factor Correction P.F.C.	>0.6		
<b>Output</b>			
Rated voltage output	DC 24 V		
Rated current output	1.2 A		
Max. output current	2.2 A @ 24 V		
Short-circuit current	–		
Voltage trim range	–		
Accuracy	±1%		
Line regulation	–		
Load regulation	<1 %		
Rise time	–		
Temperature coefficient	–		
Ripple & Noise	<50 mV pp		
Hold up time	>20 ms (AC 120 V); >60 ms (AC 240 V)		
Status indication DC ON LED green	yes		
Status indication DC LOW LED red	No		
Parallel/redundant operation	max. 2 devices / via external diodes		
Efficiency	>85 % (AC 120 V); > 87 % (AC 240 V)		
Low power loss	–		
Rated over load protection	yes		
Over voltage protection	yes		
Short circuit characteristics	Hiccup-mode		
<b>General</b>			
Switching frequency	approx. 110 kHz		
Insulation voltage input/output	AC 3.0 kV <sub>eff</sub>		
Insulation voltage input / ground	class 2, without PE		
Insulation voltage output / ground	class 2, without PE		
Insulation resistance at DC 500 V	– MΩ		
Operation temperature range	–20 °C – 60 °C (derating)		
Derating	>55°C: -0.8 W / °C		
Storage temperature range	–25 °C – 85 °C		
M.T.B.F.	750000 h to SN29500 / 250000 h to MIL Standard HDBK 217F		
Relative humidity	20–90% RH, non-condensing		
Dimensions (w × h × d) in mm	71.0 × 89.0 × 62.0		
Cooling	Natural air cooling, 10 mm distance right/left, 20 mm distance above/below		
Housing material	Noryl UL 94-0		
Field installation	rail TS 35 (EN 50022)		
Application height	– m		
Installation position	vertical		
Protection class	IP 20 (IEC529, EN60529)		
IP rating	II (SELV, PELV)		
Overvoltage category	II		
Pollution degree	2		
Weight (kg/piece)	0.200		
Termination	Screw terminal: 0.2–2.5 mm <sup>2</sup> , max. 0.56 Nm		
Approvals	UL, cUL: UL 508, IEC 950, EN 60950, UL 60950 CE: EN 61000-4-2/3/4/5/6/11, EN 61000-6-2, EN 601000-6-4, EN 50178, EN 61558, EN 61000-3-2, EN 50081-1, EN 50082-2, EN 55022 Class B, EN 55011B		
<b>Monitoring</b>			
DC ON Control (Rdy)	–		
Switching voltage	–		
Switching current	–		
Switching capacity	–		
Insulation voltage	–		

# Power supply · regulated, 50 W

## Primary switchmode power supply, Single-phase, Class 2

Input: Wide range input AC 85 V - 264 V; DC 90 V - 375 V

Output: 5 V - adjustable



### Dimensions

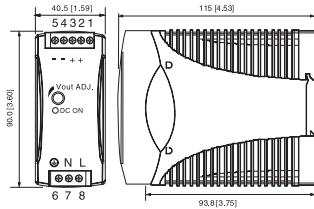

### PIN assignment

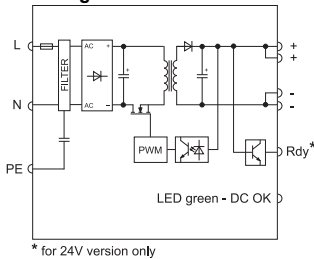

### Derating

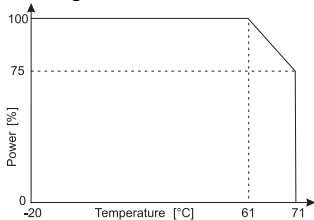

### Redundant operation

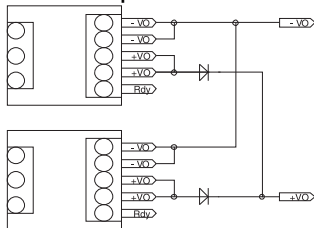

Description	Part-No.	Type	PU	
<b>Screw terminal</b>				
Output voltage/current	DC 5 V; 10 A	722764	DRA 60-05A	1
<b>Spring terminal</b>				
Output voltage/current	DC 5 V; 10 A	728764	DRA 60-05	1
<b>Input</b>		<b>DRA 60-05A</b>	<b>DRA 60-05</b>	
Nominal voltage		AC 100–240 V		
Operation voltage range		AC 85–264 V / DC 90–375 V		
Line frequency		47 – 63 Hz		
Rated current		U <sub>i</sub> = AC 115 V; AC: 550 mA / U <sub>i</sub> = 230 V; AC: 280 mA		
Inrush current		U <sub>i</sub> = AC 115 V: 20 A / U <sub>i</sub> = AC 230 V: 40 A		
Internal fuse		T2 A / AC 250 V		
External fuse		Mini-circuit breaker: B 4 A, C 2 A		
Power Factor Correction P.F.C.		–		
<b>Output</b>				
Rated voltage output		DC 5 V		
Rated current output		10 A		
Max. output current		–		
Short-circuit current		–		
Voltage trim range		5.0/5.5 V		
Accuracy		±1 %		
Line regulation		±0.5 %		
Load regulation		±0.5 %		
Rise time		1 s		
Temperature coefficient		±0.03 % / °C		
Ripple & Noise		50 mV		
Hold up time		V <sub>in</sub> = 115 V: 20 ms / V <sub>in</sub> = 230 V: 30 ms		
Status indication DC ON LED green		≥4 V		
Status indication DC LOW LED red		–		
Parallel/redundant operation		max. 2 devices / via external diodes		
Efficiency		79 %		
Low power loss		12.5 W (AC 230 V)		
Rated over load protection		110–150 %		
Over voltage protection		120–136 %		
Short circuit characteristics		Hiccup-mode		
<b>General</b>				
Switching frequency		approx. 80 kHz		
Insulation voltage input/output		AC 3.0 kV <sub>eff</sub>		
Insulation voltage input / ground		AC 1.5 kV <sub>eff</sub>		
Insulation voltage output / ground		–		
Insulation resistance at DC 500 V		100 MΩ		
Operation temperature range		-25 °C – 70 °C (derating)		
Derating		-2.5% / °C starting at 60 °C		
Storage temperature range		-25 °C – 85 °C		
M.T.B.F.		498000 h		
Relative humidity		20–90% RH, non-condensing		
Dimensions (w × h × d) in mm		40.5 × 90.0 × 115.0		
Cooling		Natural air cooling, 25 mm distance on all sides		
Housing material		Plastic		
Field installation		rail TS 35 (EN 50022)		
Application height		2000 m		
Installation position		vertical		
Protection class		IP 20		
IP rating		II (SELV, PELV)		
Overvoltage category		II		
Pollution degree		2		
Weight (kg/piece)		0.340		
Termination		Screw terminal: 0.2–2.5 mm <sup>2</sup> , max. 0.56 Nm	Spring terminal 0.2–2.0 mm <sup>2</sup>	
Approvals		UL: UL 508 listed; cUL: UL 60950-1; TÜV: EN 60950-1, CE: EN 61000-6-3 / EN 55022 Class B; EN 61000-3-2, EN 61000-3-4; EN 55024; EN 61000-6-2; EN 61000-4-2; EN 61000-4-3, EN 61000-4-4; EN 61000-4-5; EN 61000-4-6; EN 61000-4-8; EN 61000-4-11		
<b>Monitoring</b>				
DC ON Control (Rdy)		–		
Switching voltage		–		
Switching current		–		
Switching capacity		–		
Insulation voltage		–		

# Power supply - regulated, 60 W

## Primary switchmode power supply, Single-phase, Class 2

Input: Wide range input AC 85 V - 264 V; DC 90 V - 375 V

Output: 12 V / 24 V / 48 V - adjustable



### Dimensions

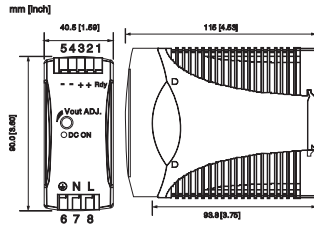

### PIN assignment

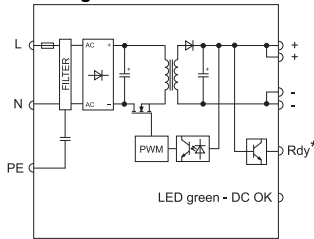

\* for 24V version only

### Derating

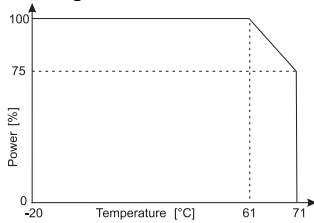

### Redundant operation

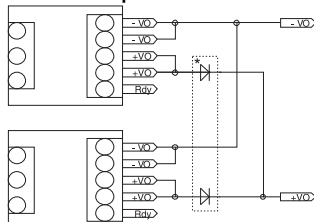

\* Redundant Module 722987  
Only use together with 24V version!

Description	Part-No.	Type	PU	
<b>Spring terminal</b>				
Output voltage/current	DC 12 V; 5 A	728769	DRA 60-12	1
	DC 24 V; 2.5 A	728754	DRA 60-24	1
	DC 48 V; 1.25 A	728776	DRA 60-48	1

Input	DRA 60-12	DRA 60-24	DRA 60-48
Nominal voltage		AC 100-240 V	
Operation voltage range	AC 85-264 V / DC 90-375 V		
Line frequency	47 - 63 Hz		
Rated current	U <sub>I</sub> = AC 115 V: 690 mA / U <sub>I</sub> = AC 230 V: 360 mA		
Inrush current	U <sub>I</sub> = AC 115 V: 20 A / U <sub>I</sub> = AC 230 V: 40 A		
Internal fuse	T2 A / AC 250 V		
External fuse	Mini-circuit breaker: B 6 A		
Power Factor Correction P.F.C.	-		

Output	DRA 60-12	DRA 60-24	DRA 60-48
Rated voltage output	DC 12 V	DC 24 V	DC 48 V
Rated current output	5 A	2.5 A	1.25 A
Max. output current	-		
Short-circuit current	-		
Voltage trim range	12/14 V	24/28 V	48/55 V
Accuracy	±1 %		
Line regulation	±0.5 %		
Load regulation	±0.5 %		
Rise time	1 s		
Temperature coefficient	±0.03 % / °C		
Ripple & Noise	50 mV		
Hold up time	V <sub>in</sub> = 115 V: 20 ms / V <sub>in</sub> = 230 V: 30 ms		
Status indication DC ON LED green	≥9.6 V	≥19.2 V	≥37 V
Status indication DC LOW LED red	-		
Parallel/redundant operation	max. 2 devices / via external diodes		
Efficiency	86 %	89 %	89 %
Low power loss	9.0 W (AC 230 V)	8.8 W (AC 230 V)	7.8 W (AC 230 V)
Rated over load protection	110-150 %		
Over voltage protection	125-138 %		
Short circuit characteristics	Hiccup-mode		

General			
Switching frequency	approx. 80 kHz		
Insulation voltage input/output	AC 3.0 kV <sub>eff</sub>		
Insulation voltage input / ground	AC 1.5 kV <sub>eff</sub>		
Insulation voltage output / ground	-		
Insulation resistance at DC 500 V	100 MΩ		
Operation temperature range	-25 °C - 70 °C (derating)		
Derating	-2.5% / °C starting at 60 °C		
Storage temperature range	-25 °C - 85 °C		
M.T.B.F.	504000 h	520000 h	531000 h
Relative humidity	20-90% RH, non-condensing		
Dimensions (w × h × d) in mm	40.5 × 90.0 × 115.0		
Cooling	Natural air cooling, 25 mm distance on all sides		
Housing material	Plastic		
Field installation	rail TS 35 (EN 50022)		
Application height	2000 m		
Installation position	vertical		
Protection class	IP 20		
IP rating	II (SELV, PELV)		
Overvoltage category	II		
Pollution degree	2		
Weight (kg/piece)	0.340		

Termination	Spring terminal 0.2-2.0 mm <sup>2</sup>		
Approvals	UL: UL 508 listed; cUL: UL 60950-1, UL 1310 Class 2 (nicht 12 V) Recognized; TÜV: EN 60950-1, EN 61558-1, EN 61558-2-17 CE: EN 61000-6-3 / EN 55022 Class B; EN 61000-3-2 EN 61000-3-3; EN 55024; EN 61000-6-2; EN 61000-4-2; EN 61000-4-3 EN 61000-4-4; EN 61000-4-5; EN 61000-4-6; EN 61000-4-8; EN 61000-4-11		

Monitoring			
DC ON Control (Rdy)	-	Open Collector	-
Switching voltage	-	DC 24 V	-
Switching current	-	≤ 35 mA	-
Switching capacity	-		
Insulation voltage	-	none	-

# Power supply · regulated, 60 W

## Primary switchmode power supply, Single-phase, Class 2

Input: Wide range input AC 85 V - 264 V; DC 90 V - 375 V

Output: 12 V / 24 V / 48 V - adjustable



### Dimensions

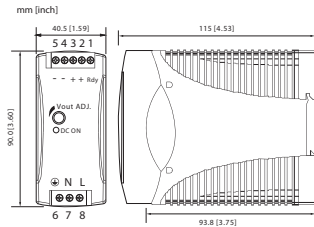

### PIN assignment

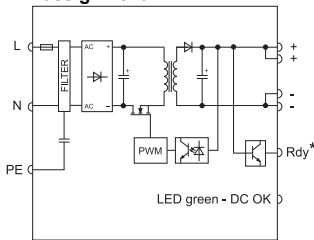

\* for 24V version only

### Derating

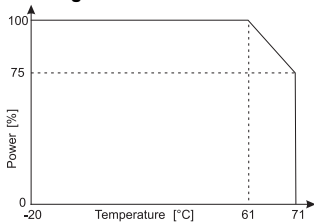

### Redundant operation

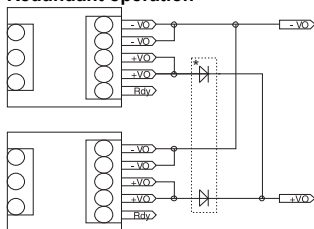

\* Redundant Module 722987  
 Only use together with 24V version!

Description	Part-No.	Type	PU	
<b>Screw terminal</b>				
Output voltage/current	DC 12 V; 5 A	722769	DRA 60-12A	1
	DC 24 V; 2.5 A	722754	DRA 60-24A	1
	DC 48 V; 1.25 A	722776	DRA 60-48A	1
<b>Input</b>				
	<b>DRA 60-12A</b>	<b>DRA 60-24A</b>	<b>DRA 60-48A</b>	
Nominal voltage	AC 100–240 V			
Operation voltage range	AC 85–264 V / DC 90–375 V			
Line frequency	47 – 63 Hz			
Rated current	U <sub>I</sub> = AC 115 V: 690 mA / U <sub>I</sub> = AC 230 V: 360 mA			
Inrush current	U <sub>I</sub> = AC 115 V: 20 A / U <sub>I</sub> = AC 230 V: 40 A			
Internal fuse	T2 A / AC 250 V			
External fuse	Mini-circuit breaker: B 6 A			
Power Factor Correction P.F.C.	–			
<b>Output</b>				
Rated voltage output	DC 12 V	DC 24 V	DC 48 V	
Rated current output	5 A	2.5 A	1.25 A	
Max. output current	–			
Short-circuit current	–			
Voltage trim range	12/14 V	24/28 V	48/55 V	
Accuracy	±1 %			
Line regulation	±0.5 %			
Load regulation	±0.5 %			
Rise time	1 s			
Temperature coefficient	±0.03 % / °C			
Ripple & Noise	50 mV			
Hold up time	V <sub>in</sub> = 115 V: 20 ms / V <sub>in</sub> = 230 V: 30 ms			
Status indication DC ON LED green	≥9.6 V	≥19.2 V	≥37 V	
Status indication DC LOW LED red	–			
Parallel/redundant operation	max. 2 devices / via external diodes			
Efficiency	86 %	89 %		
Low power loss	9.0 W (AC 230 V)	8.8 W (AC 230 V)	7.8 W (AC 230 V)	
Rated over load protection	110–150 %			
Over voltage protection	125–138 %			
Short circuit characteristics	Hiccup-mode			
<b>General</b>				
Switching frequency	approx. 80 kHz			
Insulation voltage input/output	AC 3.0 kV <sub>eff</sub>			
Insulation voltage input / ground	AC 1.5 kV <sub>eff</sub>			
Insulation voltage output / ground	–			
Insulation resistance at DC 500 V	100 MΩ			
Operation temperature range	-25 °C – 70 °C (derating)			
Derating	-2.5% / °C starting at 60 °C			
Storage temperature range	-25 °C – 85 °C			
M.T.B.F.	504000 h	520000 h	531000 h	
Relative humidity	20–90% RH, non-condensing			
Dimensions (w × h × d) in mm	40.5 × 90.0 × 115.0			
Cooling	Natural air cooling, 25 mm distance on all sides			
Housing material	Plastic			
Field installation	rail TS 35 (EN 50022)			
Application height	2000 m			
Installation position	vertical			
Protection class	IP 20			
IP rating	II (SELV, PELV)			
Overvoltage category	II			
Pollution degree	2			
Weight (kg/piece)	0.340			
Termination	Screw terminal: 0.2–2.5 mm <sup>2</sup> , max. 0.56 Nm			
Approvals	UL: UL 508 listed; cUL: UL 60950-1, UL 1310 Class 2 (nicht 12 V) Recognized; TÜV: EN 60950-1, EN 61558-1, EN 61558-2-17 CE: EN 61000-6-3 / EN 55022 Class B; EN 61000-3-2 EN 601000-3-3; EN 55024; EN 61000-6-2; EN 61000-4-2; EN 61000-4-3 EN 61000-4-4; EN 61000-4-5; EN 61000-4-6; EN 61000-4-8; EN 61000-4-11			
<b>Monitoring</b>				
DC ON Control (Rdy)	–	Open Collector	–	
Switching voltage	–	DC 24 V	–	
Switching current	–	≤ 35 mA	–	
Switching capacity	–	–	–	
Insulation voltage	–	none	–	



# Power supply - regulated, 70 W

## Primary switchmode power supply, PFC, Single-phase, Class 2

Input: Wide range input AC 90 V - 264 V; DC 100 V - 350 V

Output: DC 24 V - adjustable



### Dimensions

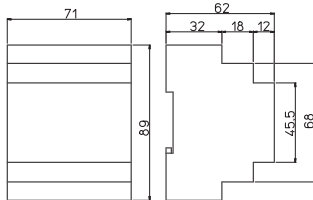

### PIN assignment

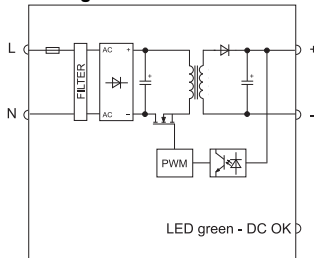

### Derating

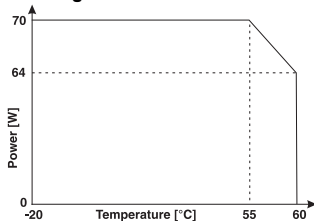

### Redundant operation

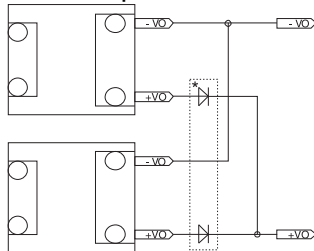

\* Redundant Module 722987

Description	Part-No.	Type	PU
<b>Screw terminal</b>			
Output voltage/current	DC 24 V; 3 A	722789	CPSF1-70-24
			1
<b>Input</b>			
<b>CPSF1-70-24</b>			
Nominal voltage	AC 115 / 230 V		
Operation voltage range	AC 90–264 V / DC 100–350 V (DC 300 V; UL508)		
Line frequency	47 – 63 Hz		
Rated current	U <sub>i</sub> = AC 100 V: 1.25 A / U <sub>i</sub> = AC 240 V: 0.80 A		
Inrush current	<AC 30 A		
Internal fuse	T2 A / AC 250 V		
External fuse	Mini-circuit breaker: B 6 A, C 4 A		
Power Factor Correction P.F.C.	>0.6		
<b>Output</b>			
Rated voltage output	DC 24 V		
Rated current output	3 A		
Max. output current	4 A @ 24 V		
Short-circuit current	–		
Voltage trim range	23.5/27.5 V		
Accuracy	–		
Line regulation	–		
Load regulation	<1 %		
Rise time	–		
Temperature coefficient	–		
Ripple & Noise	<60 mV pp		
Hold up time	>10 ms (AC 120 V); >30 ms (AC 240 V)		
Status indication DC ON LED green	yes		
Status indication DC LOW LED red	No		
Parallel/redundant operation	max. 2 devices / via external diodes		
Efficiency	>87 % (AC 120 V); > 89 % (AC 240 V)		
Low power loss	–		
Rated over load protection	yes		
Over voltage protection	yes		
Short circuit characteristics	Hiccup-mode		
<b>General</b>			
Switching frequency	approx. 70 kHz		
Insulation voltage input/output	AC 3.0 kV <sub>eff</sub>		
Insulation voltage input / ground	class 2, without PE		
Insulation voltage output / ground	class 2, without PE		
Insulation resistance at DC 500 V	– MΩ		
Operation temperature range	-20 °C – 60 °C (derating) (55°C UL508)		
Derating	>55°C: -1.2 W / °C		
Storage temperature range	-25 °C – 85 °C		
M.T.B.F.	750000 h to SN29500 / 250000 h to MIL Standard HDBK 217F		
Relative humidity	20–90% RH, non-condensing		
Dimensions (w × h × d) in mm	71.0 × 89.0 × 62.0		
Cooling	Natural air cooling, 10 mm distance right/left, 20 mm distance above/below		
Housing material	Noryl UL 94-0		
Field installation	rail TS 35 (EN 50022)		
Application height	– m		
Installation position	vertical		
Protection class	IP 20 (IEC529, EN60529)		
IP rating	II (SELV, PELV)		
Overvoltage category	II		
Pollution degree	2		
Weight (kg/piece)	0.250		
Termination	Screw terminal: 0.2–2.5 mm <sup>2</sup> , max. 0.56 Nm		
Approvals	UL, cUL: UL 508, IEC 950, EN 60950, UL 60950 CE: EN 61000-4-2/3/4/5/6/11, EN 61000-6-2, EN 601000-6-4, EN 50178, EN 61558, EN 61000-3-2, EN 50081-1, EN 50082-2, EN 55022 Class B, EN 55011B		
<b>Monitoring</b>			
DC ON Control (Rdy)	–		
Switching voltage	–		
Switching current	–		
Switching capacity	–		
Insulation voltage	–		

# Power supply · regulated, 93 W, Class 2 compliant

Primary switchmode power supply, PFC, Single-phase, screw terminal - pluggable  
 Input: Wide range input AC 90 V - 132 V; AC 186 - 264 V, DC 210 V - 370 V  
 Output: 24 V - adjustable

GB / USA



Description	Part-No.	Type	PU
<b>Screw terminal, pluggable</b>			
Output voltage/current	DC 24 V; 3.8 A	722757	DRAN 120-24AL
<b>Input</b>			
<b>DRAN 120-24AL</b>			
Nominal voltage	AC 115 / 230 V (auto select)		
Operation voltage range	AC 90–132 V; AC 186–264 V / DC 210–370 V		
Line frequency	47 – 63 Hz		
Rated current	U <sub>i</sub> = AC 115 V: 1.1 A / U <sub>i</sub> = AC 230 V: 0.55 A		
Inrush current	U <sub>i</sub> = AC 115 V: 24 A / U <sub>i</sub> = AC 230 V 48 A		
Internal fuse	T3, 15 A / AC 250 V		
External fuse	Mini-circuit breaker: B 6 A		
Power Factor Correction P.F.C.	0.7		
<b>Output</b>			
Rated voltage output	DC 24 V		
Rated current output	3.8 A		
Max. output current	–		
Short-circuit current	–		
Voltage trim range	22.5–28.5 V		
Accuracy	±1 %		
Line regulation	±0.5 %		
Load regulation	Single ±1 %, Parallel ±5 %		
Rise time	1 s		
Temperature coefficient	±0.03 % / °C		
Ripple & Noise	50 mV		
Hold up time	V <sub>in</sub> = 115 V: 25 ms / V <sub>in</sub> = 230 V: 30 ms		
Status indication DC ON LED green	≥17.6–19.4 V		
Status indication DC LOW LED red	≤17.6–19.4 V		
Parallel/redundant operation	max 2 devices with 90 % load current each / via external diodes		
Efficiency	86 %		
Low power loss	16 A (AC 230 V)		
Rated over load protection	105–125 %		
Over voltage protection	125–145 %		
Short circuit characteristics	Current limit		
<b>General</b>			
Switching frequency	approx. 80 kHz		
Insulation voltage input/output	AC 3.0 kV <sub>eff</sub>		
Insulation voltage input / ground	AC 1.5 kV <sub>eff</sub>		
Insulation voltage output / ground	–		
Insulation resistance at DC 500 V	100 MΩ		
Operation temperature range	-25 °C – 70 °C (derating)		
Derating	-2.5% / °C starting at 60 °C		
Storage temperature range	-25 °C – 85 °C		
M.T.B.F.	486000 h		
Relative humidity	20–90% RH, non-condensing		
Dimensions (w × h × d) in mm	63.5 × 142.0 × 116.0		
Cooling	Natural air cooling, 25 mm distance on all sides		
Housing material	metal		
Field installation	rail TS 35 (EN 50022)		
Application height	2000 m		
Installation position	vertical		
Protection class	IP 20		
IP rating	I (SELV, PELV)		
Overvoltage category	II		
Pollution degree	2		
Weight (kg/piece)	0.920		
Termination	Screw terminal: 0.2–2.5 mm <sup>2</sup> - pluggable, max. 0.56 Nm		
Approvals	UL: UL 508 listed, cUL: UL 60950-1, TÜV: EN 60950, EN 55022 Class B, EN 55024 Class 2, EN 61000-3-2, EN 61000-3-3, EN 61000-6-2, EN 61000-6-3		
<b>Monitoring</b>			
DC ON Control (Rdy)	Normally open		
Switching voltage	DC 60 V		
Switching current	max. 300 mA		
Switching capacity	–		
Insulation voltage	DC 500 V		

## Dimensions

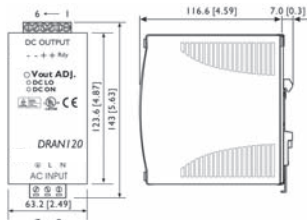

## PIN assignment

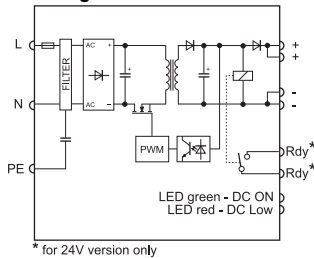

\* for 24V version only

## Derating

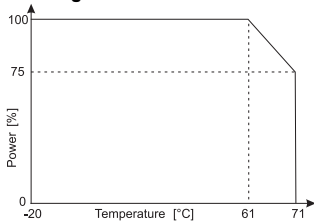

## Redundant operation

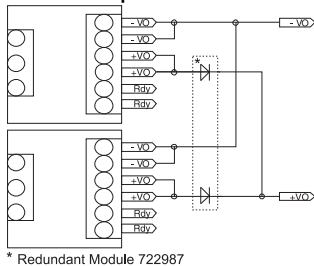

\* Redundant Module 722987

# Power supply - regulated, 120 W

**Primary switchmode power supply, PFC, Single-phase**  
**Input: Wide range input AC 90–132 V; AC 186–264 V, DC 210–370 V**  
**Output: 12 V / 24 V / 48 V - adjustable**



## Dimensions

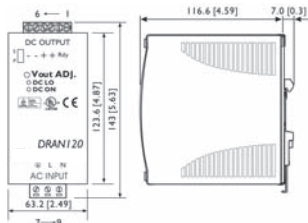

## PIN assignment

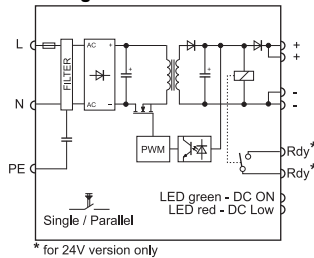

## Derating

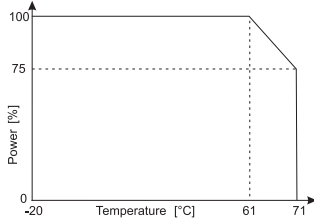

## Redundant operation

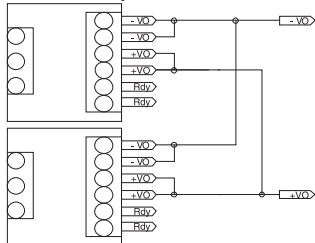

Description	Part-No.	Type	PU	
<b>Screw terminal, pluggable</b>				
Output voltage/current	DC 12 V; 10 A	722770	DRAN 120-12B	1
	DC 24 V; 5 A	722758	DRAN 120-24B	1
	DC 48 V; 2.5 A	722777	DRAN 120-48B	1
<b>Screw terminal</b>				
Output voltage/current	DC 24 V; 5 A	728758	DRAN 120-24A	1
<b>Input</b>				
	<b>DRAN 120-12B</b>	<b>DRAN 120-24B</b>	<b>DRAN 120-48B</b>	<b>DRAN 120-24A</b>
Nominal voltage	AC 115 / 230 V (auto select)			
Operation voltage range	AC 90–132 V; AC 186–264 V / DC 210–370 V			
Line frequency	47 – 63 Hz			
Rated current	U <sub>i</sub> = AC 115 V: 1.25 A / U <sub>i</sub> = AC 230 V: 0.63 A			
Inrush current	U <sub>i</sub> = AC 115 V: 24 A / U <sub>i</sub> = AC 230 V: 48 A			
Internal fuse	T3, 15 A / AC 250 V			
External fuse	Mini-circuit breaker: B 6 A			
Power Factor Correction P.F.C.	0.7			
<b>Output</b>				
Rated voltage output	DC 12 V	DC 24 V	DC 48 V	DC 24 V
Rated current output	10 A	5 A	2.5 A	5 A
Max. output current	–			
Short-circuit current	–			
Voltage trim range	11.4–14.5 V	22.5–28.5 V	45/55 V	22.5–28.5 V
Accuracy	±1 %			
Line regulation	±0.5 %			
Load regulation	Single ±1 %, Parallel ±5 %			
Rise time	1 s			
Temperature coefficient	±0.03 % / °C			
Ripple & Noise	50 mV			
Hold up time	V <sub>in</sub> = 115 V: 25 ms / V <sub>in</sub> = 230 V: 30 ms			
Status indication DC ON LED green	≥10–11.2 V	≥17.6–19.4 V	≥37–43 V	≥17.6–19.4 V
Status indication DC LOW LED red	≤10–11.2 V	≤17.6–19.4 V	≤37–43 V	≤17.6–19.4 V
Parallel/redundant operation	max. 3 units at 90% load current, manual switch			
Efficiency	84 %	86 %	87 %	86 %
Low power loss	24 A (AC 230 V)	20 A (AC 230 V)	19 A (AC 230 V)	20 A (AC 230 V)
Rated over load protection	105–125 %			
Over voltage protection	125–145 %			
Short circuit characteristics	Current limit			
<b>General</b>				
Switching frequency	approx. 80 kHz			
Insulation voltage input/output	AC 3.0 kV <sub>eff</sub>			
Insulation voltage input / ground	AC 1.5 kV <sub>eff</sub>			
Insulation voltage output / ground	–			
Insulation resistance at DC 500 V	100 MΩ			
Operation temperature range	-25 °C – 70 °C (derating)			
Derating	-2.5% / °C starting at 60 °C			
Storage temperature range	-25 °C – 85 °C			
M.T.B.F.	440000 h	450000 h	482000 h	450000 h
Relative humidity	20–90% RH, non-condensing			
Dimensions (w × h × d) in mm	63.5 × 142.0 × 116.0			
Cooling	Natural air cooling, 25 mm distance on all sides			
Housing material	metal			
Field installation	rail TS 35 (EN 50022)			
Application height	2000 m			
Installation position	vertical			
Protection class	IP 20			
IP rating	I (SELV, PELV)			
Overvoltage category	II			
Pollution degree	2			
Weight (kg/piece)	0.920			
Termination	Screw terminal: 0.2–2.5 mm <sup>2</sup> - pluggable,max. 0.56 Nm			Screw terminal: 0.2–4.0 mm <sup>2</sup> ,max. 0.62 Nm
Approvals	UL: UL 508 listed; cUL: UL 60950-1; TÜV: EN 60950, CE: EN 61000-6-3, EN 55022 Class B, EN 61000-3-2, EN 61000-3-3, EN 61000-6-2, EN 55024			
<b>Monitoring</b>				
DC ON Control (Rdy)	–	Normally open	–	Normally open
Switching voltage	–	DC 60 V	–	DC 60 V
Switching current	–	max. 300 mA	–	max. 300 mA
Switching capacity	–			
Insulation voltage	–	DC 500 V	–	DC 500 V

# Power supply · regulated, 120 W

**Primary switchmode power supply, PFC, Single-phase**  
**Input: Wide range input AC 90 V - 264 V; DC 120 V - 370 V**  
**Output: 24 V - adjustable**



## Dimensions

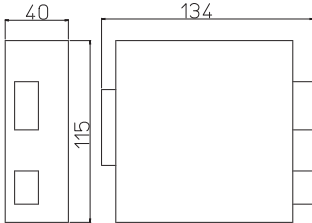

## PIN assignment

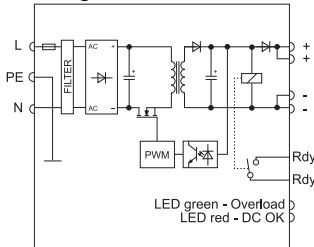

## Derating

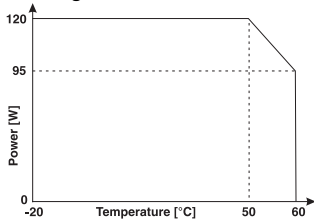

## Redundant operation

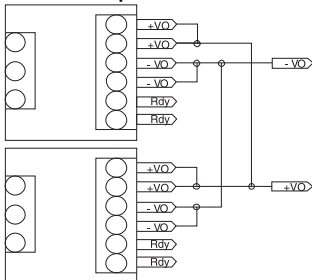

Description	Part-No.	Type	PU	
<b>Screw terminal</b>				
Output voltage/current	DC 24 V; 5 A	722783	CPSB1-120-24R	1
	DC 48 V; 2.5 A	722784	CPSB1-120-48R	1

Input	CPSB1-120-24R	CPSB1-120-48R
Nominal voltage	AC 120 V / 230 V	
Operation voltage range	AC 90–264 V / DC 110–370 V	
Line frequency	47 – 63 Hz	
Rated current	U <sub>i</sub> = AC 115 V: 1.9 A / U <sub>i</sub> = AC 230 V: 1.1 A	
Inrush current	<AC 20 A	
Internal fuse	T3, 15 A / AC 250 V	
External fuse	Mini-circuit breaker: B 6 A, C 4 A	
Power Factor Correction P.F.C.	>0.6	
<b>Output</b>		
Rated voltage output	DC 24 V	DC 48 V
Rated current output	5 A	2.5 A
Max. output current	8 A, 30 s, @ 24 V	4 A, 30 s, @ 24 V
Short-circuit current	15 A, 50 ms	
Voltage trim range	DC 23–27.5 V	DC 45–55 V
Accuracy	–	
Line regulation	–	
Load regulation	<1 %	
Rise time	–	
Temperature coefficient	–	
Ripple & Noise	30 mV	
Hold up time	>17 ms (AC 120 V); >72 ms (AC 230 V)	
Status indication DC ON LED green	≥21.6 V	≥43.2 V
Status indication DC LOW LED red	≤21.6 V	≤43.2 V
Parallel/redundant operation	max. 2 devices / via internal diodes	
Efficiency	>90 % (AC 230 V); > 86 % (AC 120 V)	
Low power loss	19 W (AC 120 V); 13 W (AC 230 V)	20 W (AC 120 V); 13 W (AC 230 V)
Rated over load protection	yes	
Over voltage protection	yes	
Short circuit characteristics	Hiccup-mode	
<b>General</b>		
Switching frequency	approx. 110 kHz	
Insulation voltage input/output	AC 3.0 kV <sub>eff</sub>	
Insulation voltage input / ground	AC 1.5 kV <sub>eff</sub>	
Insulation voltage output / ground	AC 0.5 kV <sub>eff</sub>	
Insulation resistance at DC 500 V	– MΩ	
Operation temperature range	–20 °C – 60 °C (derating)	
Derating	>50°C: –2.5 W / °C	
Storage temperature range	–25 °C – 85 °C	
M.T.B.F.	>500000 h to SN29500 / >150000 h to MIL standard HDBK 217F	
Relative humidity	20–90% RH, non-condensing	
Dimensions (w × h × d) in mm	40.0 × 115.0 × 128.0	
Cooling	Natural air cooling, 10 mm distance right/left, 50 mm distance above/below	
Housing material	Aluminium	
Field installation	rail TS 35 (EN 50022)	
Application height	– m	
Installation postition	vertical	
Protection class	IP 20 (IEC529, EN60529)	
IP rating	I (SELV, PELV)	
Overvoltage category	II	
Pollution degree	2	
Weight (kg/piece)	0.400	
Termination	Screw terminal: 0.2–2.5 mm <sup>2</sup> - pluggable, max. 0.56 Nm	
Approvals	UL, cUL: UL 508, IEC 950, EN 60950, UL 60950 CE: EN 61000-4-2/3/4/5/6/11, EN 61000-6-2, EN 601000-6-4, EN 50178, EN 61558, EN 50081-1, EN 50082-2, EN 55022 Class B	
<b>Monitoring</b>		
DC ON Control (Rdy)	Normally open	
Switching voltage	AC 300 V / DC 150 V	
Switching current	AC/DC 1 A	
Switching capacity	300 VA / 30 W	
Insulation voltage	AC 500 V	

# Power supply · regulated, 120 Watts, IP 65

**Primary switchmode power supply, PFC, Single-phase**  
**Input: Wide range input AC 90 V - 264 V; DC 110 V - 300 V**  
**Output: DC 24 V - adjustable**



## Dimensions

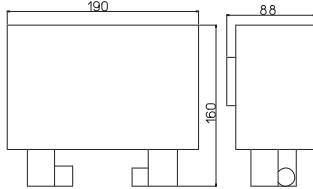

## PIN assignment

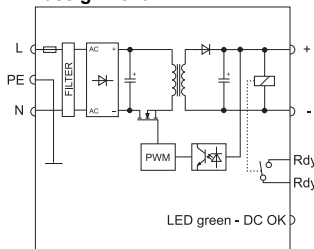

## Redundant operation

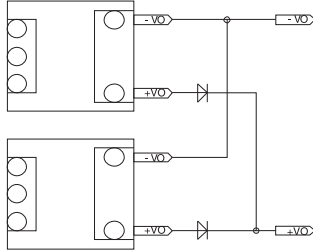

Description	Part-No.	Type	PU
<b>Screw terminal, pluggable</b>			
Output voltage/current	DC 24 V; 5 A	722794	CPS65-120-24
			1
<b>Input</b>			
<b>CPS65-120-24</b>			
Nominal voltage	AC 120 V / 230 V		
Operation voltage range	AC 90–264 V / DC 110–300 V		
Line frequency	47 – 63 Hz		
Rated current	U <sub>I</sub> = AC 120 V: 1.8 A / U <sub>I</sub> = AC 240 V: 1.0 A		
Inrush current	<AC 20 A		
Internal fuse	T3, 15 A / AC 250 V		
External fuse	Mini-circuit breaker: B 6 A, C 4 A		
Power Factor Correction P.F.C.	>0.7		
<b>Output</b>			
Rated voltage output	DC 24 V		
Rated current output	5 A		
Max. output current	8 A (AC 120 V), 10 A (AC 230 V)		
Short-circuit current	–		
Voltage trim range	DC 23–27.5 V		
Accuracy	–		
Line regulation	–		
Load regulation	<1 %		
Rise time	–		
Temperature coefficient	–		
Ripple & Noise	<80 mV (AC 120 V), < 50 mV (AC 230 V)		
Hold up time	>20 ms (AC 230 V)		
Status indication DC ON LED green	yes		
Status indication DC LOW LED red	No		
Parallel/redundant operation	max. 2 devices / via external diodes		
Efficiency	>86 % (AC 120 V); > 90 % (AC 240 V)		
Low power loss	18.6 W (AC 120 V); 12.6 W (AC 240 V)		
Rated over load protection	yes		
Over voltage protection	yes		
Short circuit characteristics	Hiccup-mode		
<b>General</b>			
Switching frequency	approx. 70 – 110 kHz		
Insulation voltage input/output	AC 3.0 kV <sub>eff</sub>		
Insulation voltage input / ground	AC 1.5 kV <sub>eff</sub>		
Insulation voltage output / ground	AC 0.5 kV <sub>eff</sub>		
Insulation resistance at DC 500 V	– MΩ		
Operation temperature range	-20 °C – 60 °C		
Derating	–		
Storage temperature range	-25 °C – 85 °C		
M.T.B.F.	750000 h to SN29500 / 250000 h to MIL Standard HDBK 217F		
Relative humidity	20–90% RH, non-condensing		
Dimensions (w × h × d) in mm	190.0 × 80.0 × 120.0		
Cooling	Natural air cooling, 10 mm distance right/left, 50 mm distance above/below		
Housing material	Noryl UL 94-0		
Field installation	rail TS 35 (EN 50022)		
Application height	– m		
Installation position	vertical		
Protection class	IP 65 (IEC529, EN60529)		
IP rating	I (SELV, PELV)		
Overvoltage category	II		
Pollution degree	2		
Weight (kg/piece)	1.300		
Termination	Screw terminal: 0.2–2.5 mm <sup>2</sup> - pluggable,max. 0.56 Nm		
Approvals	UL, cUL: UL 508, IEC 950, EN 60950 CE: EN 61000-4-2/3/4/5/6/11, EN 61000-6-2, EN 601000-6-4, EN 50178, EN 61558, EN 50081-1, EN 50082-2, EN 61000-3-2		
<b>Monitoring</b>			
DC ON Control (Rdy)	Normally open		
Switching voltage	AC 300 V / DC 150 V		
Switching current	AC/DC 1 A		
Switching capacity	300 VA / 30 W		
Insulation voltage	AC 500 V		

# Power supply · regulated, 120 W, 2-phase

## Primary switchmode power supply, PFC, 1- / 2-phase

Input: Wide range input AC 187 V - 550 V; DC 270 V - 725 V

Output: 24 V - adjustable



### Dimensions

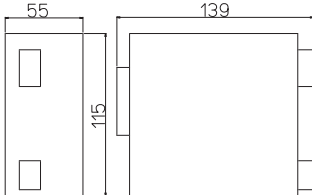

### PIN assignment

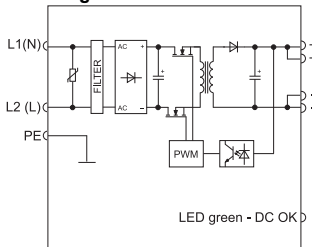

### Derating

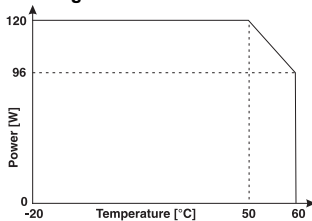

### Redundant operation

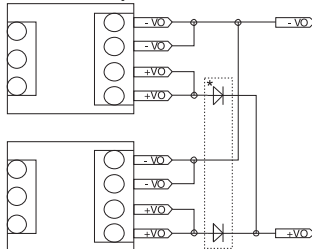

\* Redundant Module 722987

Description	Part-No.	Type	PU
<b>Screw terminal, pluggable</b>			
Output voltage/current	DC 24 V; 5 A	722983	CPSB2-120-24
			1
<b>Input</b>			
<b>CPSB2-120-24</b>			
Nominal voltage	AC 200–500 V		
Operation voltage range	AC 187–550 V, DC 270–725 V		
Line frequency	47 – 63 Hz		
Rated current	U <sub>I</sub> = AC 200 V: 1.2 A / U <sub>I</sub> = AC 500 V: 0.5 A		
Inrush current	<AC 20 A (AC 200 V); <AC 45 A (AC 500 V)		
Internal fuse	–		
External fuse	Mini-circuit breaker: B 10 A, C 6 A		
Power Factor Correction P.F.C.	>0.7		
<b>Output</b>			
Rated voltage output	DC 24 V		
Rated current output	5 A		
Max. output current	5.5 A, @ 24 V		
Short-circuit current	22 A (AC 200 V), 32 A (AC 500 V) 0.50 sec.		
Voltage trim range	23/27.5 V		
Accuracy	–		
Line regulation	–		
Load regulation	<1 %		
Rise time	–		
Temperature coefficient	–		
Ripple & Noise	50 mV pp		
Hold up time	>20 ms (AC 200 V); >200 ms (AC 500 V)		
Status indication DC ON LED green	≥21.6 V		
Status indication DC LOW LED red	≤21.6 V		
Parallel/redundant operation	max. 2 devices / via external diodes		
Efficiency	>86 %		
Low power loss	22 A (AC 230 V)		
Rated over load protection	yes		
Over voltage protection	yes		
Short circuit characteristics	Hiccup-mode		
<b>General</b>			
Switching frequency	approx. 70 – 110 kHz		
Insulation voltage input/output	AC 3.0 kV <sub>eff</sub>		
Insulation voltage input / ground	AC 2.0 kV <sub>eff</sub>		
Insulation voltage output / ground	AC 0.5 kV <sub>eff</sub>		
Insulation resistance at DC 500 V	– MΩ		
Operation temperature range	–20 °C – 60 °C (derating)		
Derating	>50°C: –2.4 W / °C		
Storage temperature range	–25 °C – 85 °C		
M.T.B.F.	750000 h to SN29500 / 250000 h to MIL Standard HDBK 217F		
Relative humidity	20–90% RH, non-condensing		
Dimensions (w × h × d) in mm	55.0 × 115.0 × 130.0		
Cooling	Natural air cooling, 10 mm distance right/left, 50 mm distance above/below		
Housing material	Aluminium		
Field installation	rail TS 35 (EN 50022)		
Application height	– m		
Installation position	vertical		
Protection class	IP 20 (IEC529, EN60529)		
IP rating	I (SELV, PELV)		
Overvoltage category	II		
Pollution degree	2		
Weight (kg/piece)	0.600		
Termination	Screw terminal: 0.2–2.5 mm <sup>2</sup> - pluggable, max. 0.56 Nm		
Approvals	UL, cUL: UL 508, IEC 950, EN 60950 CE: EN 61000-4-2/3/4/5/6/11, EN 61000-6-2, EN 601000-6-4, EN 50178, EN 61558, EN 50081-1, EN 50082-2, EN 55022 Class B		
<b>Monitoring</b>			
DC ON Control (Rdy)	Normally open		
Switching voltage	AC 300 V / DC 150 V		
Switching current	AC/DC 1 A		
Switching capacity	300 VA / 30 W		
Insulation voltage	AC 500 V		

# Power supply - regulated, 120 W, 3-phase

**Primary switchmode power supply, PFC, 3-phase**  
**Input: Wide range input AC 340 V - 576 V; DC 480 V - 820 V**  
**Output: 24 V - adjustable**



## Dimensions

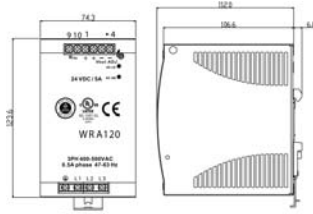

## PIN assignment

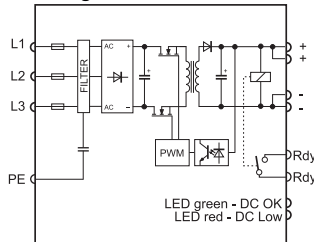

## Derating

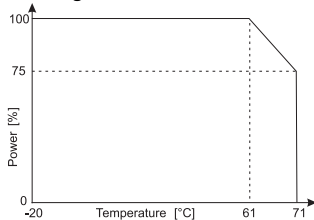

## Redundant operation

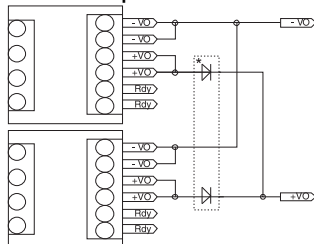

\* Redundant Module 722987

Description	Part-No.	Type	PU
<b>Screw terminal</b>			
Output voltage/current	DC 24 V; 5 A	722803	1
<b>Input</b>			
<b>WRA 120-24</b>			
Nominal voltage	3× AC 380–480 V		
Operation voltage range	3× AC 340–575 V, 3× DC 480–820 V		
Line frequency	47 – 63 Hz		
Rated current	U <sub>I</sub> = AC 380 V: 0.5 A / U <sub>I</sub> = AC 500 V: 0.35 A		
Inrush current	10 A		
Internal fuse	3×T2, 0 A / AC 600 V		
External fuse	Mini-circuit breaker: 3× B 4 A		
Power Factor Correction P.F.C.	0.6		
<b>Output</b>			
Rated voltage output	DC 24 V		
Rated current output	5 A		
Max. output current	–		
Short-circuit current	–		
Voltage trim range	22.5/28.5 V		
Accuracy	1 %		
Line regulation	±1 %		
Load regulation	±1 %		
Rise time	1 s		
Temperature coefficient	±0.03 % / °C		
Ripple & Noise	100 mV		
Hold up time	min. 20 ms		
Status indication DC ON LED green	≥17.6–19.4 V		
Status indication DC LOW LED red	≤17.6–19.4 V		
Parallel/redundant operation	max. 2 devices / via external diodes		
Efficiency	89 %		
Low power loss	16 W (AC 380 V)		
Rated over load protection	115 - 135 %, temperature: disconnection at 100–110°C and automatic activation when cool off		
Over voltage protection	125–137 %		
Short circuit characteristics	Hiccup-mode		
<b>General</b>			
Switching frequency	approx. 70 kHz		
Insulation voltage input/output	AC 3.0 kV <sub>eff</sub>		
Insulation voltage input / ground	AC 1.5 kV <sub>eff</sub>		
Insulation voltage output / ground	–		
Insulation resistance at DC 500 V	100 MΩ		
Operation temperature range	-25 °C – 71 °C (derating)		
Derating	Capacity: -2.5% / °C starting at +61 °C		
Storage temperature range	-25 °C – 85 °C		
M.T.B.F.	559000 h		
Relative humidity	20–90% RH, non-condensing		
Dimensions (w × h × d) in mm	74.3 × 123.6 × 118.8		
Cooling	Natural air cooling, 25 mm distance on all sides		
Housing material	Metal		
Field installation	rail TS 35 (EN 50022)		
Application height	3000 m		
Installation position	vertical		
Protection class	IP 20		
IP rating	I (SELV, PELV)		
Overvoltage category	II		
Pollution degree	2		
Weight (kg/piece)	0.800		
Termination	Screw terminal: 0.2–4.0 mm <sup>2</sup> , max. 0.62 Nm		
Approvals	UL: UL 508 listed, cUL: UL 60950-1 accepted, TÜV: EN 60950-1; CE: EN 61000-6-3 / EN 55022 Class B, EN 61000-3-2, EN 61000-3-3, EN 61000-6-2, EN 55024		
<b>Monitoring</b>			
DC ON Control (Rdy)	Normally open		
Switching voltage	DC 60 V		
Switching current	max. 300 mA		
Switching capacity	–		
Insulation voltage	DC 500 V		

# Power supply · regulated, 240 W

## Primary switchmode power supply, PFC, Single-phase

Input: Wide range input AC 93 - 132 V; AC 186 - 264 V, DC 210 - 370 V

Output: 24 V / 48 V - adjustable



### Dimensions

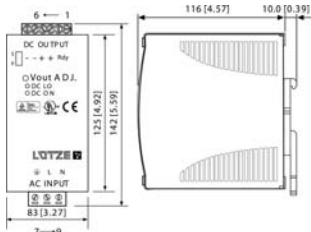

### PIN assignment

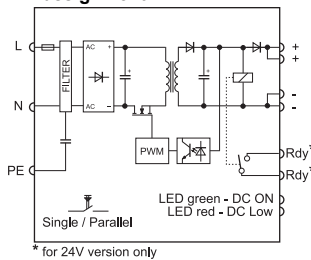

### Derating

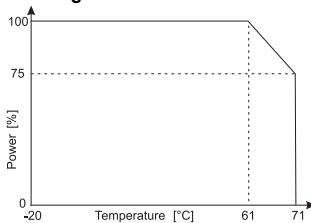

### Redundant operation

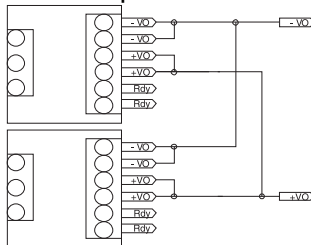

Description	Part-No.	Type	PU	
<b>Screw terminal, pluggable</b>				
Output voltage/current	DC 24 V; 10 A	722759	DRA 240-24B	1
	DC 48 V; 5 A	722778	DRA 240-48B	1
<b>Screw terminal</b>				
Output voltage/current	DC 24 V; 10 A	722781	DRA 240-24A	1
<b>Input</b>				
	<b>DRA 240-24B</b>	<b>DRA 240-48B</b>	<b>DRA 240-24A</b>	
Nominal voltage	AC 115 / 230 V (auto select)			
Operation voltage range	AC 93–132 V, AC 186–264 V, DC 210–370 V			
Line frequency	47 – 63 Hz			
Rated current	U <sub>i</sub> = AC 115 V: 2.4 A / U <sub>i</sub> = AC 230 V: 1.2 A			
Inrush current	U <sub>i</sub> = AC 115 V: 30 A / U <sub>i</sub> = AC 230 V: 60 A			
Internal fuse	T6, 3 A / AC 250 V			
External fuse	Mini-circuit breaker: B 10 A, C 6 A			
Power Factor Correction P.F.C.	0.7			
<b>Output</b>				
Rated voltage output	DC 24 V	DC 48 V	DC 24 V	
Rated current output	10 A	5 A	10 A	
Max. output current	–			
Short-circuit current	–			
Voltage trim range	22.5–28.5	47/56 V	22.5–28.5 V	
Accuracy	±1 %			
Line regulation	±0.5 %			
Load regulation	Single ±1 %, Parallel ±5 %			
Rise time	1 s			
Temperature coefficient	±0.03 % / °C			
Ripple & Noise	100 mV			
Hold up time	V <sub>in</sub> = 115 V: 25 ms / V <sub>in</sub> = 230 V: 30 ms			
Status indication DC ON LED green	≥17.6–19.4 V	≥37–43 V	≥17.6–19.4 V	
Status indication DC LOW LED red	≤17.6–19.4 V	≤37–43 V	≤17.6–19.4 V	
Parallel/redundant operation	max 3 devices with 90 % load current each, switching with switch S/P			
Efficiency	89 %	90 %	89 %	
Low power loss	35 A (AC 230 V)	32 A (AC 230 V)	35 A (AC 230 V)	
Rated over load protection	105–145 %			
Over voltage protection	120–145 %			
Short circuit characteristics	Current limit			
<b>General</b>				
Switching frequency	approx. 40 kHz			
Insulation voltage input/output	AC 3.0 kV <sub>eff</sub>			
Insulation voltage input / ground	AC 1.5 kV <sub>eff</sub>			
Insulation voltage output / ground	–			
Insulation resistance at DC 500 V	100 MΩ			
Operation temperature range	-25 °C – 70 °C (derating)			
Derating	-2.5 % / °C starting at 60 °C			
Storage temperature range	-25 °C – 85 °C			
M.T.B.F.	423000 h	437000 h	423000 h	
Relative humidity	20–90% RH, non-condensing			
Dimensions (w × h × d) in mm	83.0 × 142.0 × 116.0			
Cooling	Natural air cooling, 25 mm distance on all sides			
Housing material	metal			
Field installation	rail TS 35 (EN 50022)			
Application height	2000 m			
Installation position	vertical			
Protection class	IP 20			
IP rating	I (SELV, PELV)			
Overvoltage category	II			
Pollution degree	2			
Weight (kg/piece)	1.000			
Termination	Screw terminal: 0.2–2.5 mm <sup>2</sup> - pluggable, max. 0.56 Nm		Screw terminal: 0.2–4.0 mm <sup>2</sup> , max. 0.62 Nm	
Approvals	UL: UL 508 listed; cUL: UL 60950-1; TÜV: EN 60950, CE: EN 61000-6-3, EN 55022 Class B, EN 61000-3-2, EN 61000-3-3, EN 61000-6-2, EN 55024			
<b>Monitoring</b>				
DC ON Control (Rdy)	Normally open	–	Normally open	
Switching voltage	DC 60 V	–	DC 60 V	
Switching current	max. 300 mA	–	max. 300 mA	
Switching capacity	–	–	–	
Insulation voltage	DC 500 V	–	DC 500 V	



# Power supply - regulated, 240 W

**Primary switchmode power supply, PFC, Single-phase**  
**Input: AC 90–132 V; AC 185–264 V; DC 300–350 V**  
**Output: 24 V - adjustable**



## Dimensions

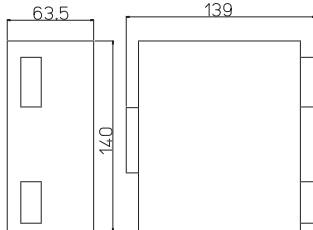

## PIN assignment

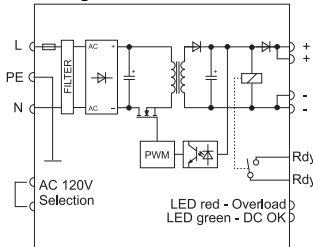

## Derating

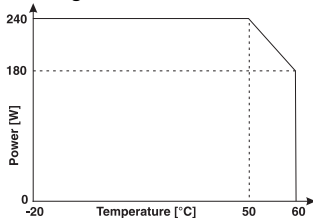

## Redundant operation

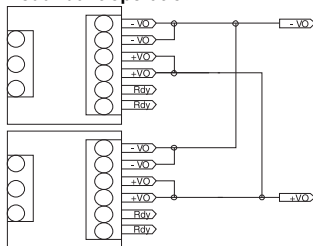

Description	Part-No.	Type	PU	
<b>Screw terminal, pluggable</b>				
Output voltage/current	DC 24 V; 10 A	722785	CPSB1-240-24R	1
	DC 48 V; 5 A	722786	CPSB1-240-48R	1

Input	CPSB1-240-24R	CPSB1-240-48R
Nominal voltage	AC 120 / 230 V (manual)	
Operation voltage range	AC 90–132 V, AC 185–264 V, DC 300–370 V	
Line frequency	47 – 63 Hz	
Rated current	U <sub>i</sub> = AC 115 V: 3.5 A / U <sub>i</sub> = AC 230 V: 1.8 A	
Inrush current	U <sub>i</sub> = AC 115 V: 30 A / U <sub>i</sub> = AC 230 V: 35 A	
Internal fuse	T6, 3 A / AC 250 V	
External fuse	Mini-circuit breaker: C 10 A	
Power Factor Correction P.F.C.	>0.6	

Output	CPSB1-240-24R	CPSB1-240-48R
Rated voltage output	DC 24 V	DC 48 V
Rated current output	10 A	5 A
Max. output current	15 A, 30 s. @ 24 V	7.5 A, 30 s. @ 24 V
Short-circuit current	25 A, 400 ms	
Voltage trim range	23/27.5 V	45/55 V
Accuracy	–	
Line regulation	–	
Load regulation	1 %	
Rise time	–	
Temperature coefficient	–	
Ripple & Noise	50 mV	
Hold up time	>30 ms (120 V); >60 ms (230 V)	
Status indication DC ON LED green	≥21.6 V	≥43.2 V
Status indication DC LOW LED red	≤21.6 V	≤43.2 V
Parallel/redundant operation	max. 2 devices / via internal diodes	
Efficiency	89 %	90 %
Low power loss	26 A (AC 230 V)	
Rated over load protection	yes	
Over voltage protection	yes	
Short circuit characteristics	Hiccup-mode	

General	
Switching frequency	approx. 110 kHz
Insulation voltage input/output	AC 3.0 kV <sub>eff</sub>
Insulation voltage input / ground	AC 1.5 kV <sub>eff</sub>
Insulation voltage output / ground	AC 0.5 kV <sub>eff</sub>
Insulation resistance at DC 500 V	– MΩ
Operation temperature range	–20 °C – 60 °C (derating)
Derating	>50°C: –6 W / °C
Storage temperature range	–25 °C – 85 °C
M.T.B.F.	>500000 h to SN29500 / >150000 h to MIL standard HDBK 217F
Relative humidity	20–90% RH, non-condensing
Dimensions (w × h × d) in mm	63.5 × 140.0 × 139.0
Cooling	Natural air cooling, 20 mm distance right/left, 100 mm distance above/below
Housing material	Aluminium
Field installation	rail TS 35 (EN 50022)
Application height	– m
Installation position	vertical
Protection class	IP 20 (IEC529, EN60529)
IP rating	I (SELV, PELV)
Overvoltage category	III
Pollution degree	2
Weight (kg/piece)	0.720
Termination	Screw terminal: 0.2–2.5 mm <sup>2</sup> - pluggable,max. 0.56 Nm
Approvals	UL, cUL: UL 508, IEC 950, EN 60950, UL 60950 CE: EN 61000-4-2/3/4/5/6/11, EN 61000-6-2, EN 601000-6-4, EN 50178, EN 61558, EN 50081-1, EN 50082-2, EN 55022 Class B

Monitoring	
DC ON Control (Rdy)	Normally open
Switching voltage	AC 300 V / DC 150 V
Switching current	AC/DC 1 A
Switching capacity	300 VA / 30 W
Insulation voltage	AC 500 V

# Power supply · regulated, 240 W, 2-phase

## Primary switchmode power supply, PFC, 1- / 2-phase

Input: Wide range input AC 187 V - 550 V; DC 270 V - 725 V

Output: 24 V - adjustable



### Dimensions

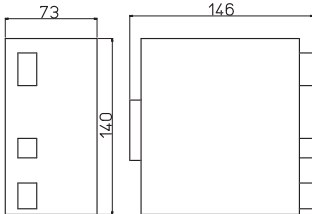

### PIN assignment

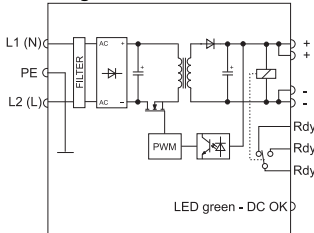

### Derating

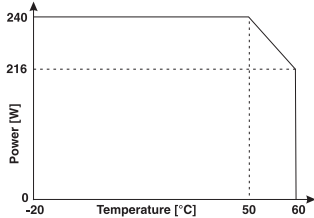

### Redundant operation

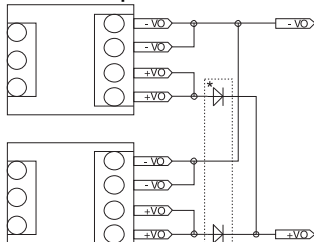

\* Redundant Module 722987

Description	Part-No.	Type	PU
<b>Screw terminal, pluggable</b>			
Output voltage/current	DC 24 V; 10 A	722984	CPSB2-240-24
			1
<b>Input</b>			
<b>CPSB2-240-24</b>			
Nominal voltage	AC 200–500 V		
Operation voltage range	AC 187–550 V; DC 270–725 V		
Line frequency	47 – 63 Hz		
Rated current	U <sub>I</sub> = AC 200 V: 2.0 A / U <sub>I</sub> = AC 500 V: 1.0 A		
Inrush current	<AC 40 A		
Internal fuse	–		
External fuse	Mini-circuit breaker: B 10 A, C 6 A		
Power Factor Correction P.F.C.	>0.8		
<b>Output</b>			
Rated voltage output	DC 24 V		
Rated current output	10 A		
Max. output current	12 A, @ 24 V		
Short-circuit current	30 A, 500 ms		
Voltage trim range	23/27.5 V		
Accuracy	–		
Line regulation	–		
Load regulation	<1 %		
Rise time	–		
Temperature coefficient	–		
Ripple & Noise	<80 mV pp		
Hold up time	>20 ms (AC 200 V); >120 ms (AC 500 V)		
Status indication DC ON LED green	≥21.6 V		
Status indication DC LOW LED red	≤21.6 V		
Parallel/redundant operation	max. 2 devices / via external diodes		
Efficiency	>89 %		
Low power loss	29 A (AC 230 V)		
Rated over load protection	yes		
Over voltage protection	yes		
Short circuit characteristics	Hiccup-mode		
<b>General</b>			
Switching frequency	approx. 70 – 110 kHz		
Insulation voltage input/output	AC 3.0 kV <sub>eff</sub>		
Insulation voltage input / ground	AC 2.0 kV <sub>eff</sub>		
Insulation voltage output / ground	AC 0.5 kV <sub>eff</sub>		
Insulation resistance at DC 500 V	– MΩ		
Operation temperature range	–20 °C – 60 °C (derating)		
Derating	>50°C: –2.4 W / °C		
Storage temperature range	–25 °C – 85 °C		
M.T.B.F.	750000 h to SN29500 / 250000 h to MIL Standard HDBK 217F		
Relative humidity	20–90% RH, non-condensing		
Dimensions (w × h × d) in mm	73.0 × 140.0 × 146.0		
Cooling	Natural air cooling, 20 mm distance right/left, 100 mm distance above/below		
Housing material	Aluminium		
Field installation	rail TS 35 (EN 50022)		
Application height	– m		
Installation position	vertical		
Protection class	IP 20 (IEC529, EN60529)		
IP rating	I (SELV, PELV)		
Overvoltage category	II		
Pollution degree	2		
Weight (kg/piece)	1.100		
Termination	Screw terminal: 0.2–2.5 mm <sup>2</sup> - pluggable, max. 0.56 Nm		
Approvals	UL, cUL: UL 508, IEC 950, EN 60950 CE: EN 61000-4-2/3/4/5/6/11, EN 61000-6-2, EN 601000-6-4, EN 50178, EN 61558, EN 50081-1, EN 50082-2, EN 55022 Class B		
<b>Monitoring</b>			
DC ON Control (Rdy)	1 changeover contact		
Switching voltage	AC 300 V / DC 150 V		
Switching current	AC/DC 1 A		
Switching capacity	300 VA / 30 W		
Insulation voltage	AC 500 V		

# Power supply · regulated, 240 W, 3-phase

## Primary switchmode power supply, PFC, 3-phase

Input: Wide range input AC 400 - 500 V

Output: 24 V - adjustable



### Dimensions

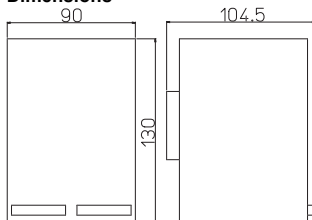

### PIN assignment

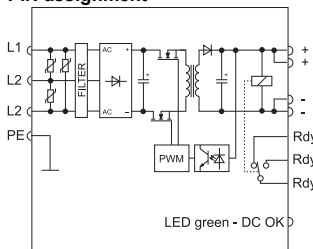

### Derating

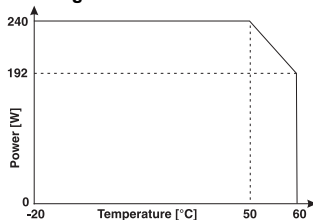

### Redundant operation

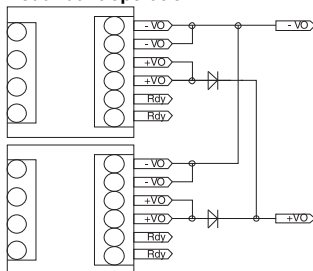

Description	Part-No.	Type	PU
<b>Screw terminal</b>			
Output voltage/current	DC 24 V; 10 A	722799	CPSB3-240-24
			1
<b>Input</b>		<b>CPSB3-240-24</b>	
Nominal voltage	3× AC 400–500 V		
Operation voltage range	3× AC 340–550 V; 3× DC 507–770 V		
Line frequency	47 – 63 Hz		
Rated current	U <sub>I</sub> = AC 400 V: 1.3 A / U <sub>I</sub> = AC 500 V: 1.1 A		
Inrush current	<AC 30 A		
Internal fuse	–		
External fuse	Mini-circuit breaker: 3× B 10 A, C 6 A		
Power Factor Correction P.F.C.	>0.6		
<b>Output</b>			
Rated voltage output	DC 24 V		
Rated current output	10 A @ 45 °C (UL508)		
Max. output current	14 A, @ 24 V		
Short-circuit current	20 A		
Voltage trim range	24/28 V		
Accuracy	–		
Line regulation	–		
Load regulation	<1 %		
Rise time	–		
Temperature coefficient	–		
Ripple & Noise	50 mV pp		
Hold up time	>11 ms (AC 500 V)		
Status indication DC ON LED green	≥21.6 V		
Status indication DC LOW LED red	≤21.6 V		
Parallel/redundant operation	max. 2 devices / via external diodes		
Efficiency	>90 % (AC 400 V)		
Low power loss	27 A (AC 380 V)		
Rated over load protection	yes		
Over voltage protection	yes		
Short circuit characteristics	Hiccup-mode		
<b>General</b>			
Switching frequency	–		
Insulation voltage input/output	AC 3.0 kV <sub>eff</sub>		
Insulation voltage input / ground	AC 2.0 kV <sub>eff</sub>		
Insulation voltage output / ground	AC 0.5 kV <sub>eff</sub>		
Insulation resistance at DC 500 V	– MΩ		
Operation temperature range	–20 °C – 60 °C (derating)		
Derating	>50 °C: –4.8 W / °C		
Storage temperature range	–25 °C – 85 °C		
M.T.B.F.	>500000 h to SN29500 / >150000 h to MIL standard HDBK 217F		
Relative humidity	20–90% RH, non-condensing		
Dimensions (w × h × d) in mm	90.0 × 130.0 × 104.5		
Cooling	Natural air cooling, 10 mm distance right/left, 50 mm distance above/below		
Housing material	Aluminium		
Field installation	rail TS 35 (EN 50022)		
Application height	– m		
Installation position	vertical		
Protection class	IP 20 (IEC529, EN60529)		
IP rating	I (SELV, PELV)		
Overvoltage category	II		
Pollution degree	2		
Weight (kg/piece)	0.700		
Termination	Screw terminal: 0.2–4.0 mm <sup>2</sup> , max. 0.62 Nm		
Approvals	UL, cUL: UL 508, IEC 950, EN 60950 CE: EN 61000-4-2/3/4/5/6/11, EN 61000-6-2, EN 601000-6-4, EN 50178, EN 61558, EN 50081-1, EN 50082-2, EN 55022 Class B		
<b>Monitoring</b>			
DC ON Control (Rdy)	Changeover contact		
Switching voltage	AC 300 V / DC 150 V		
Switching current	AC/DC 1 A		
Switching capacity	300 VA / 30 W		
Insulation voltage	AC 500 V		

# Power supply · regulated, 240 W, 3-phase

## Primary switchmode power supply, PFC, 3-phase

Input: Wide range input AC 340 V - 576 V; DC 480 V - 820 V

Output: 24–48 V - adjustable



### Dimensions

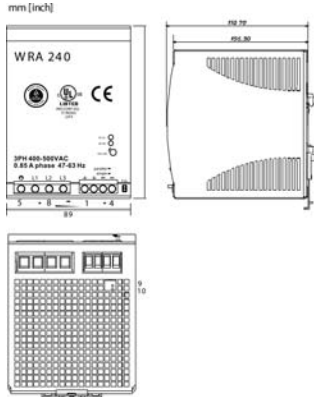

### PIN assignment

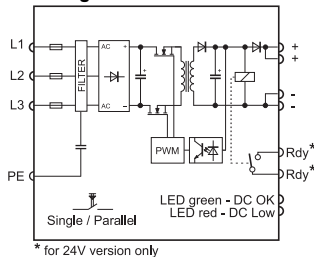

### Derating

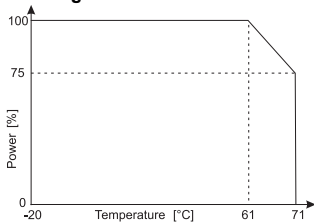

### Redundant operation

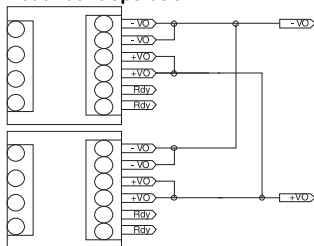

Description	Part-No.	Type	PU
<b>Screw terminal</b>			
Output voltage/current	DC 24 V; 10 A	722804	WRA 240-24
	DC 48 V; 5 A	722808	WRA 240-48

Input	WRA 240-24	WRA 240-48
Nominal voltage	3× AC 340–500 V	
Operation voltage range	3× AC 340–575 V; 3× DC 480–820 V	
Line frequency	47 – 63 Hz	
Rated current	U <sub>I</sub> = AC 380 V: 0.85 A / U <sub>I</sub> = AC 500 V: 0.7 A	
Inrush current	20 A	
Internal fuse	3×T2, 0 A / AC 600 V	
External fuse	Mini-circuit breaker: 3× B 6 A	
Power Factor Correction P.F.C.	0.6	
<b>Output</b>		
Rated voltage output	DC 24 V	
Rated current output	10 A	5 A
Max. output current	–	
Short-circuit current	–	
Voltage trim range	22.5/28.5 V	47–56 V
Accuracy	1 %	
Line regulation	±1 %	
Load regulation	Single ±1 %, Parallel ±5 %	
Rise time	1 s	
Temperature coefficient	±0.03 % / °C	
Ripple & Noise	100 mV	
Hold up time	min. 20 ms	
Status indication DC ON LED green	≥17.6–19.4 V	≥37–43 V
Status indication DC LOW LED red	≤17.6–19.4 V	≤37–43 V
Parallel/redundant operation	max 2 devices with 90 % load current each, switching with switch S/P	
Efficiency	90 %	91 %
Low power loss	30 A (AC 380 V)	24 A (AC 380 V)
Rated over load protection	Temperature: Deactivation at 100–110°C and automatic activation after cooling off	
Over voltage protection	125–137 %	125–142 %
Short circuit characteristics	Hiccup-mode	
<b>General</b>		
Switching frequency	approx. 25 kHz	
Insulation voltage input/output	AC 3.0 kV <sub>eff</sub>	
Insulation voltage input / ground	AC 1.5 kV <sub>eff</sub>	
Insulation voltage output / ground	–	
Insulation resistance at DC 500 V	100 MΩ	
Operation temperature range	-25 °C – 71 °C (derating)	
Derating	Capacity: -2.5% / °C starting at +61 °C	
Storage temperature range	-25 °C – 85 °C	
M.T.B.F.	488000 h	519000 h
Relative humidity	20–90% RH, non-condensing	
Dimensions (w × h × d) in mm	89.0 × 123.6 × 117.5	
Cooling	Natural air cooling, 25 mm distance on all sides	
Housing material	Metal	
Field installation	rail TS 35 (EN 50022)	
Application height	3000 m	
Installation postition	vertical	
Protection class	IP 20	
IP rating	I (SELV, PELV)	
Overvoltage category	II	
Pollution degree	2	
Weight (kg/piece)	1.100	
Termination	Screw terminal: 0.2–4.0 mm <sup>2</sup> , max. 0.62 Nm	
Approvals	UL: UL 508 listed; cUL: UL 60950-1 accepted; TÜV: EN 60950-1, CE: EN 61000-6-3 / EN 55022 Class B, EN 61000-3-2, EN 61000-3-3, EN 61000-6-2, EN 55024	
<b>Monitoring</b>		
DC ON Control (Rdy)	Normally open	–
Switching voltage	DC 60 V	–
Switching current	max. 300 mA	–
Switching capacity	–	–
Insulation voltage	DC 500 V	–

# Power supply - regulated, 480 W

**Primary switchmode power supply, PFC, Single-phase**  
**Input: Wide range input AC 90 - 264 V; DC 120 - 370 V**  
**Output: 24 V / 48 V - adjustable**



## Dimensions

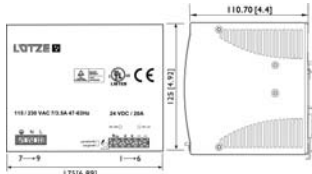

## PIN assignment

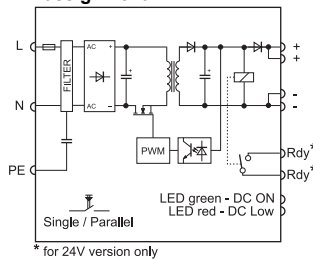

## Derating

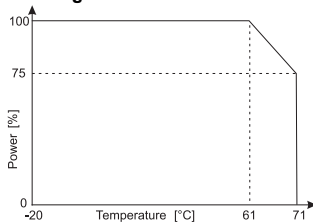

## Redundant operation

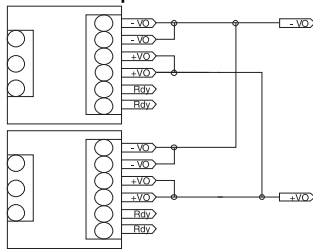

Description	Part-No.	Type	PU	
<b>Screw terminal</b>				
Output voltage/current	DC 24 V; 20 A	722782	DRA 480-24A	1
	DC 48 V; 10 A	722779	DRA 480-48A	1

Input	DRA 480-24A	DRA 480-48A
Nominal voltage	AC 115 / 230 V (auto select)	
Operation voltage range	AC 90–264 V; DC 120–370 V	
Line frequency	47 – 63 Hz	
Rated current	U <sub>i</sub> = AC 115 V: 4.8 A / U <sub>i</sub> = AC 230 V: 2.45 A	
Inrush current	U <sub>i</sub> = AC 115 V: 25 A / U <sub>i</sub> = AC 230 V: 50 A	
Internal fuse	T10 A / AC 250 V	
External fuse	Mini-circuit breaker: B 16 A	
Power Factor Correction P.F.C.	0.99	

Output	DRA 480-24A	DRA 480-48A
Rated voltage output	DC 24 V	DC 48 V
Rated current output	20 A	10 A
Max. output current	–	
Short-circuit current	–	
Voltage trim range	22.5–28.5 V	47/56 V
Accuracy	±1 %	
Line regulation	±0.5 %	
Load regulation	Single ±0.5 %, Parallel ±5 %	
Rise time	1 s	
Temperature coefficient	±0.03 % / °C	
Ripple & Noise	100 mV	
Hold up time	min. 30 ms	
Status indication DC ON LED green	≥17.6–19.4 V	≥37–40 V
Status indication DC LOW LED red	≤17.6–19.4 V	≤37–43 V
Parallel/redundant operation	max 3 devices with 90 % load current each, switching with switch S/P	
Efficiency	89 %	90 %
Low power loss	63 A (AC 230 V)	60 A (AC 230 V)
Rated over load protection	120–140 %	
Over voltage protection	125–137 %	119–131 %
Short circuit characteristics	Current limit	

<b>General</b>			
Switching frequency	approx. 60 kHz		
Insulation voltage input/output	AC 3.0 kV <sub>eff</sub>		
Insulation voltage input / ground	AC 1.5 kV <sub>eff</sub>		
Insulation voltage output / ground	–		
Insulation resistance at DC 500 V	100 MΩ		
Operation temperature range	-25 °C – 71 °C (derating)		
Derating	-4% / °C starting at 61 °C		
Storage temperature range	-25 °C – 85 °C		
M.T.B.F.	403000 h		416000 h
Relative humidity	20–90% RH, non-condensing		
Dimensions (w × h × d) in mm	175.0 × 125.0 × 116.0		
Cooling	Natural air cooling, 25 mm distance on all sides		
Housing material	metal		
Field installation	rail TS 35 (EN 50022)		
Application height	2000 m		
Installation position	vertical		
Protection class	IP 20		
IP rating	I (SELV, PELV)		
Overvoltage category	II		
Pollution degree	2		
Weight (kg/piece)	1.920		
Termination	Screw terminal: 0.2–4.0 mm <sup>2</sup> , max. 0.62 Nm		
Approvals	UL: UL 508 listed; cUL: UL 60950-1 accepted; TÜV: EN 60950-1, CE: EN 61000-6-3 / EN 55022 Class B, EN 61000-3-2, EN 61000-3-3, EN 61000-6-2, EN 55024		

<b>Monitoring</b>			
DC ON Control (Rdy)	Normally open		–
Switching voltage	DC 60 V		–
Switching current	max. 300 mA		–
Switching capacity			–
Insulation voltage	DC 500 V		–

# Power supply · regulated, 480 W

Primary switchmode power supply, PFC, Single-phase

Input: AC 90-132 V; AC 187-264 V

Output: 24 V - adjustable



## Dimensions

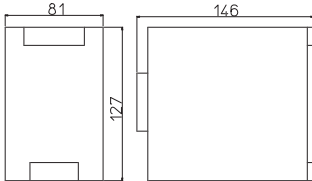

## PIN assignment

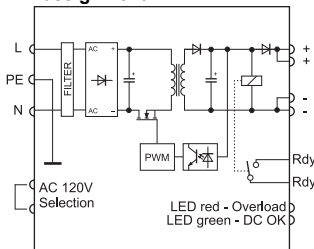

## Derating

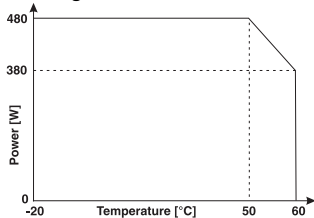

## Redundant operation

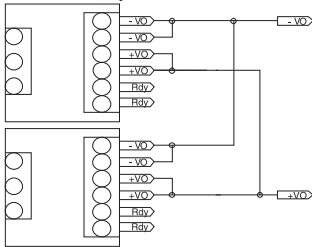

Description	Part-No.	Type	PU	
<b>Screw terminal</b>				
Output voltage/current	DC 24 V; 20 A	722986	CPSB1-480-24R	1
	DC 48 V; 10 A	722989	CPSB1-480-48R	1

Input	CPSB1-480-24R	CPSB1-480-48R
Nominal voltage	AC 120 V / AC 240 V	
Operation voltage range	AC 90–132 V / AC 187–264 V	
Line frequency	47 – 63 Hz	
Rated current	U <sub>i</sub> = AC 120 V: 6 A / U <sub>i</sub> = AC 230 V: 3.5 A	
Inrush current	<AC 35 A	
Internal fuse	–	
External fuse	Mini-circuit breaker: C 16 A	
Power Factor Correction P.F.C.	>0.6	

Output	CPSB1-480-24R	CPSB1-480-48R
Rated voltage output	DC 24 V	DC 48 V
Rated current output	20 A	10 A
Max. output current	30 A, 5 s, @ 24 V	15 A, 5 s, @ 48 V
Short-circuit current	>55 A, 5 s	>40 A, 5 s
Voltage trim range	23/48 V	45/55 V
Accuracy	–	
Line regulation	–	
Load regulation	<1 %	
Rise time	–	
Temperature coefficient	–	
Ripple & Noise	100 mV pp	
Hold up time	>35 ms (AC 240 V)	
Status indication DC ON LED green	≥21.6 V	≥43.2 V
Status indication DC LOW LED red	≤21.6 V	≤43.2 V
Parallel/redundant operation	max. 2 devices / via internal diodes	
Efficiency	>92 % (AC 240 V)	
Low power loss	45 A (AC 230 V)	
Rated over load protection	yes	
Over voltage protection	yes	
Short circuit characteristics	Hiccup-mode	

<b>General</b>			
Switching frequency	approx. 70 – 110 kHz		
Insulation voltage input/output	AC 3.0 kV <sub>eff</sub>		
Insulation voltage input / ground	AC 2.0 kV <sub>eff</sub>		
Insulation voltage output / ground	AC 0.7 kV <sub>eff</sub>		
Insulation resistance at DC 500 V	– MΩ		
Operation temperature range	-20 °C – 60 °C (derating)		
Derating	>50°C: -10 W / °C		
Storage temperature range	-25 °C – 85 °C		
M.T.B.F.	750000 h to SN29500 / 250000 h to MIL Standard HDBK 217F		
Relative humidity	20–90% RH, non-condensing		
Dimensions (w × h × d) in mm	81.0 × 127.0 × 146.0		
Cooling	Natural air cooling, 10 mm distance right/left, 50 mm distance above/below		
Housing material	Aluminium		
Field installation	rail TS 35 (EN 50022)		
Application height	– m		
Installation position	vertical		
Protection class	IP 20 (IEC529, EN60529)		
IP rating	I (SELV, PELV)		
Overvoltage category	II		
Pollution degree	2		
Weight (kg/piece)	1.100		
Termination	Screw terminal: 0.2–6.0 mm <sup>2</sup> , max. 0.62 Nm		
Approvals	UL, cUL: UL 508, IEC 950, EN 60950 CE: EN 61000-4-2/3/4/5/6/11, EN 61000-6-2, EN 601000-6-4, EN 50178, EN 61558, EN 50081-1, EN 50082-2, EN 55022 Class B		

<b>Monitoring</b>	
DC ON Control (Rdy)	Normally open
Switching voltage	AC 300 V / DC 150 V
Switching current	AC/DC 1 A
Switching capacity	300 VA / 30 W
Insulation voltage	AC 500 V

# Power supply · regulated, 480 W, 3-phase

## Primary switchmode power supply, PFC, 3-phase

Input: Wide range input AC 340 - 576 V; DC 480 - 820 V

Output: 24 V / 48 V - adjustable



### Dimensions

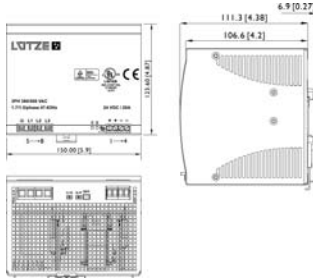

### PIN assignment

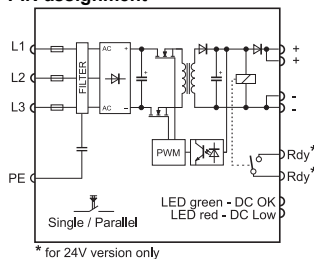

### Derating

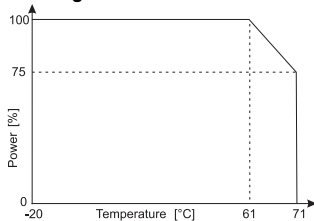

### Redundant operation

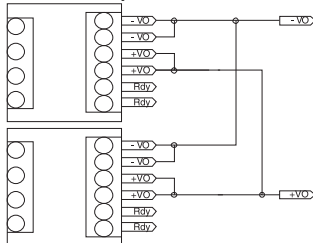

Description	Part-No.	Type	PU	
<b>Screw terminal</b>				
Output voltage/current	DC 24 V; 20 A	722805	WRA 480-24	1
	DC 48 V; 10 A	722809	WRA 480-48	1

Input	WRA 480-24	WRA 480-48
Nominal voltage	3× AC 380–500 V	
Operation voltage range	3× AC 340–576 V; 3× DC 480–820 V	
Line frequency	47 – 63 Hz	
Rated current	U <sub>I</sub> = AC 400 V: 1.5 A / U <sub>I</sub> = AC 480 V: 1.2 A	
Inrush current	20 A	
Internal fuse	T3, 15 A / per phase	
External fuse	Mini-circuit breaker: 3× B 10 A, C 6 A	
Power Factor Correction P.F.C.	0.7	

Output	DC 24 V	DC 48 V
Rated voltage output	DC 24 V	DC 48 V
Rated current output	20 A	10 A
Max. output current	–	
Short-circuit current	–	
Voltage trim range	22.5 – 28.5 V	47/56 V
Accuracy	1 %	
Line regulation	±1 %	
Load regulation	Single ±1 %, Parallel ±5 %	
Rise time	–	
Temperature coefficient	±0.03 % / °C	
Ripple & Noise	100 mV	
Hold up time	min. 20 ms	
Status indication DC ON LED green	≥17.6–19.4 V	≥37–43 V
Status indication DC LOW LED red	≤17.6–19.4 V	≤37–43 V
Parallel/redundant operation	max 3 devices with 90 % load current each, switching with switch S/P	
Efficiency	90 %	
Low power loss	58 A (AC 380 V)	55 A (AC 380 V)
Rated over load protection	115–135 %	
Over voltage protection	125–137 %	125–142 %
Short circuit characteristics	Current limit (C) / Hiccup-Mode (D); switching with switch C/D Hiccup-Mode: deactivation within 3s and restart after 30s	

General		
Switching frequency	approx. 80 kHz	
Insulation voltage input/output	AC 3.0 kV <sub>eff</sub>	
Insulation voltage input / ground	AC 1.5 kV <sub>eff</sub>	
Insulation voltage output / ground	–	
Insulation resistance at DC 500 V	100 MΩ	
Operation temperature range	-25 °C – 71 °C (derating)	
Derating	-2.5% / °C starting at 61 °C	
Storage temperature range	-25 °C – 85 °C	
M.T.B.F.	411000 h	423000 h
Relative humidity	20–90% RH, non-condensing	
Dimensions (w × h × d) in mm	150.0 × 125.0 × 116.0	
Cooling	Natural air cooling, 25 mm distance on all sides	
Housing material	metal	
Field installation	rail TS 35 (EN 50022)	
Application height	3000 m	
Installation position	vertical	
Protection class	IP 20	
IP rating	I (SELV, PELV)	
Overvoltage category	II	
Pollution degree	2	
Weight (kg/piece)	1.750	
Termination	Screw terminal: 0.2–4.0 mm <sup>2</sup> , max. 0.62 Nm	
Approvals	UL: UL 508 listed; cUL: UL 60950-1 accepted; TÜV: EN 60950-1; CE: EN 61000-6-3 / EN 55022 Class B, EN 61000-3-2, EN 61000-3-3, EN 61000-6-2, EN 55024	

Monitoring		
DC ON Control (Rdy)	Normally open	–
Switching voltage	DC 60 V	–
Switching current	max. 300 mA	–
Switching capacity	–	–
Insulation voltage	DC 500 V	–

# Power supply · regulated, 480 W, 3-phase

## Primary switchmode power supply, PFC, 3-phase

Input: Wide range input AC 340 - 550 V

Output: 24 V - adjustable



### Dimensions

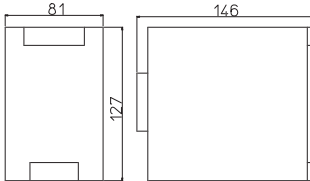

### PIN assignment

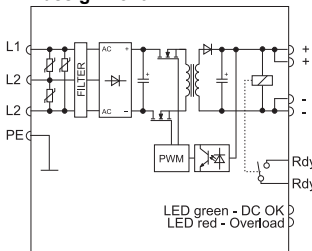

### Derating

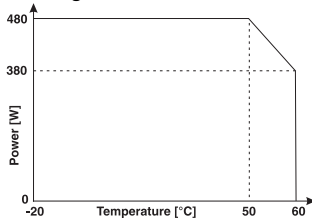

### Redundant operation

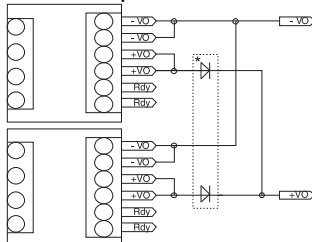

\* Redundant Module 722987

Description	Part-No.	Type	PU	
<b>Screw terminal</b>				
Output voltage/current	DC 24 V; 20 A	722800	CPSB3-500-24	1
<b>Input</b>				
<b>CPSB3-500-24</b>				
Nominal voltage	3× AC 400–500 V			
Operation voltage range	3× AC 340–550 V			
Line frequency	47 – 63 Hz			
Rated current	U <sub>I</sub> = AC 400 V: 1.3 A / U <sub>I</sub> = AC 500 V: 1.1 A			
Inrush current	<AC 40 A			
Internal fuse	–			
External fuse	Mini-circuit breaker: 3× B 16 A, C 10 A			
Power Factor Correction P.F.C.	>0.6			
<b>Output</b>				
Rated voltage output	DC 24 V			
Rated current output	20 A			
Max. output current	30 A, 5 s, @ 24 V			
Short-circuit current	>55 A, 5 s			
Voltage trim range	24/28 V			
Accuracy	–			
Line regulation	–			
Load regulation	<1 %			
Rise time	–			
Temperature coefficient	–			
Ripple & Noise	100 mV pp			
Hold up time	>15 ms (AC 400 V)			
Status indication DC ON LED green	≥21.6 V			
Status indication DC LOW LED red	≤21.6 V			
Parallel/redundant operation	max. 2 devices / via external diodes			
Efficiency	>94 % (AC 400 V)			
Low power loss	30 A (AC 380 V)			
Rated over load protection	yes			
Over voltage protection	yes			
Short circuit characteristics	Hiccup-mode			
<b>General</b>				
Switching frequency	approx. 70 – 110 kHz			
Insulation voltage input/output	AC 3.0 kV <sub>eff</sub>			
Insulation voltage input / ground	AC 2.0 kV <sub>eff</sub>			
Insulation voltage output / ground	AC 0.5 kV <sub>eff</sub>			
Insulation resistance at DC 500 V	– MΩ			
Operation temperature range	–20 °C – 60 °C (derating)			
Derating	>50°C: –10 W / °C			
Storage temperature range	–25 °C – 85 °C			
M.T.B.F.	>500000 h to SN29500 / >150000 h to MIL standard HDBK 217F			
Relative humidity	20–90% RH, non-condensing			
Dimensions (w × h × d) in mm	81.0 × 127.0 × 146.0			
Cooling	Natural air cooling, 10 mm distance right/left, 50 mm distance above/below			
Housing material	Aluminium			
Field installation	rail TS 35 (EN 50022)			
Application height	– m			
Installation position	vertical			
Protection class	IP 20 (IEC529, EN60529)			
IP rating	I (SELV, PELV)			
Overvoltage category	II			
Pollution degree	2			
Weight (kg/piece)	1,200			
Termination	Screw terminal: 0.2–6.0 mm <sup>2</sup> , max. 0.62 Nm			
Approvals	UL, cUL: UL 508, IEC 950, EN 60950 CE: EN 61000-4-2/3/4/5/6/11, EN 61000-6-2, EN 601000-6-4, EN 50178, EN 61558, EN 50081-1, EN 50082-2, EN 55022 Class B			
<b>Monitoring</b>				
DC ON Control (Rdy)	Normally open			
Switching voltage	AC 300 V / DC 150 V			
Switching current	AC/DC 1 A			
Switching capacity	300 VA / 30 W			
Insulation voltage	AC 500 V			



# Power supply · regulated, 720 W, 3-phase

## Primary switchmode power supply, PFC, 3-phase

Input: Wide range input AC 340 - 550 V

Output: 24 V - adjustable



### Dimensions

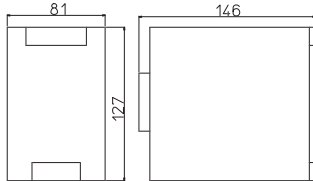

### PIN assignment

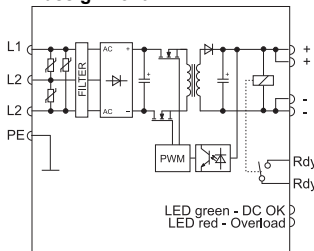

### Derating

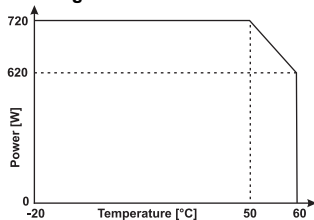

### Redundant operation

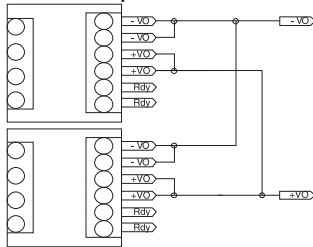

Description	Part-No.	Type	PU	
<b>Screw terminal</b>				
Output voltage/current	DC 24 V; 30 A	722802	CPSB3-720-24	1
	DC 48 V; 15 A	722807	CPSB3-720-48	1

Input	CPSB3-720-24	CPSB3-720-48
Nominal voltage	3× AC 400–500 V	
Operation voltage range	3× AC 340–550 V	
Line frequency	47 – 63 Hz	
Rated current	U <sub>I</sub> = AC 400 V: 2.1 A / U <sub>I</sub> = AC 500 V: 1.8 A	
Inrush current	<AC 10 A	
Internal fuse	–	
External fuse	Mini-circuit breaker: 3× B 16 A, C 10 A	
Power Factor Correction P.F.C.	>0.6	

Output	CPSB3-720-24	CPSB3-720-48
Rated voltage output	DC 24 V	DC 48 V
Rated current output	30 A	15 A
Max. output current	45 A, 5 s, @ 24 V	20 A, 5 s, @ 48 V
Short-circuit current	60 A, 5 s	30 A, 5 s
Voltage trim range	24/28 V	45/55 V
Accuracy	–	
Line regulation	–	
Load regulation	<1 %	
Rise time	–	
Temperature coefficient	–	
Ripple & Noise	100 mV pp	
Hold up time	>15 ms (AC 400 V)	
Status indication DC ON LED green	≥21.6 V	≥43.2 V
Status indication DC LOW LED red	≤21.6 V	≤43.2 V
Parallel/redundant operation	max. 2 devices / via external diodes	
Efficiency	>94 % (AC 400 V)	–
Low power loss	55 A (AC 380 V)	–
Rated over load protection	> 90°C, auto-reset	
Over voltage protection	<33 V	<60 V
Short circuit characteristics	Hiccup mode, 5 s ON / 7 s OFF	

General			
Switching frequency	approx. 70 – 110 kHz		
Insulation voltage input/output	AC 3.0 kV <sub>eff</sub>		
Insulation voltage input / ground	AC 2.0 kV <sub>eff</sub>		
Insulation voltage output / ground	AC 1.0 kV <sub>eff</sub>		
Insulation resistance at DC 500 V	– MΩ		
Operation temperature range	-20 °C – 60 °C		
Derating	>50°C: -10 W / °C		
Storage temperature range	-25 °C – 85 °C		
M.T.B.F.	>500000 h to SN29500 / >150000 h to MIL standard HDBK 217F		
Relative humidity	20–90% RH, non-condensing		
Dimensions (w × h × d) in mm	81.0 × 127.0 × 146.0		
Cooling	Natural air cooling, forced cooling >50°C, 50 mm distance above/below		
Housing material	Aluminium		
Field installation	rail TS 35 (EN 50022)		
Application height	– m		
Installation position	vertical		
Protection class	IP 20 (IEC529, EN60529)		
IP rating	I (SELV, PELV)		
Overvoltage category	II		
Pollution degree	2		
Weight (kg/piece)	1.200		
Termination	Screw terminal: 0.2–6.0 mm <sup>2</sup> , max. 0.62 Nm		
Approvals	UL, cUL: UL 508, IEC 950, EN 60950 CE: EN 61000-4-2/3/4/5/6/11, EN 61000-6-2, EN 601000-6-4, EN 50178, EN 61558, EN 50081-1, EN 50082-2, EN 55022 Class B		

Monitoring	
DC ON Control (Rdy)	Normally open
Switching voltage	AC 300 V / DC 150 V
Switching current	AC/DC 1 A
Switching capacity	300 VA / 30 W
Insulation voltage	AC 500 V

# Power supply · regulated, 960 W, 3-phase

**Primary switchmode power supply, PFC, 3-phase**  
**Input: Wide range input AC 340 - 576 V; DC 480 - 820 V**  
**Output: 24 V / 48 V - adjustable**



## Dimensions

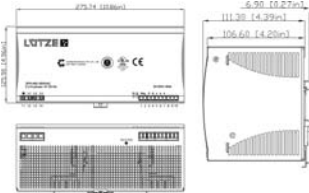

## PIN assignment

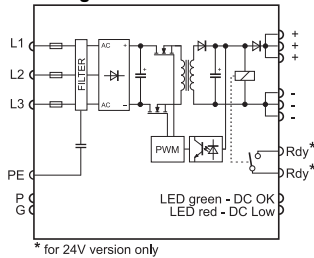

## Derating

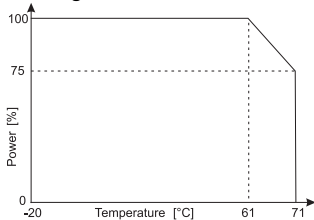

## Redundant operation

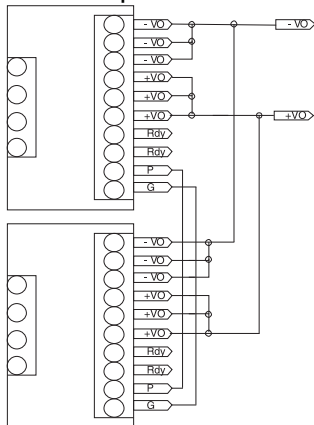

Description	Part-No.	Type	PU	
<b>Screw terminal</b>				
Output voltage/current	DC 24 V; 40 A	722806	WRA 960-24	1
	DC 48 V; 20 A	722810	WRA 960-48	1

Input	WRA 960-24	WRA 960-48
Nominal voltage	3× AC 400–500 V	
Operation voltage range	3× AC 340–575 V; 3× DC 480–820 V	
Line frequency	47 – 63 Hz	
Rated current	U <sub>i</sub> = AC 400 V: 2.4 A / U <sub>i</sub> = AC 480 V: 1.6 A	
Inrush current	30 A	
Internal fuse	T6, 3 A / per phase	
External fuse	Mini-circuit breaker: 3× B 16 A, C 10 A	
Power Factor Correction P.F.C.	0.7	

Output	DC 24 V	DC 48 V
Rated voltage output	DC 24 V	DC 48 V
Rated current output	40 A	20 A
Max. output current	–	
Short-circuit current	–	
Voltage trim range	22.5–28.5 V	47/56 V
Accuracy	1 %	
Line regulation	±1 %	
Load regulation	Single ±1 %, Parallel ±5 %	
Rise time	1 s	
Temperature coefficient	±0.03 % / °C	
Ripple & Noise	80 mV	
Hold up time	15 ms	
Status indication DC ON LED green	≥17.6–19.4 V	≥37–43 V
Status indication DC LOW LED red	≤17.6–19.4 V	≤37–43 V
Parallel/redundant operation	max 2 devices with 92 % load current each, connection P and G for distributed current	

Efficiency	92 %	93 %
Low power loss	–	
Rated over load protection	Rated over load protection: 110 % –130 %	
Over voltage protection	125–137 %	125–142 %
Short circuit characteristics	Hiccup-mode	

General	
Switching frequency	approx. 52 kHz
Insulation voltage input/output	AC 3.0 kV <sub>eff</sub>
Insulation voltage input / ground	AC 1.5 kV <sub>eff</sub>
Insulation voltage output / ground	–
Insulation resistance at DC 500 V	100 MΩ
Operation temperature range	-25 °C – 71 °C (derating)
Derating	-3.5% / °C starting at 61°C
Storage temperature range	-25 °C – 85 °C

M.T.B.F.	352000 h	390000 h
Relative humidity	20–90% RH, non-condensing	
Dimensions (w × h × d) in mm	276.0 × 125.0 × 118.0	
Cooling	Natural air cooling, 25 mm distance on all sides	
Housing material	metal	
Field installation	rail TS 35 (EN 50022)	
Application height	3000 m	
Installation position	vertical	
Protection class	IP 20	
IP rating	I (SELV, PELV)	
Overvoltage category	II	
Pollution degree	2	
Weight (kg/piece)	3.200	
Termination	Screw terminal: 0.5–10.0 mm <sup>2</sup> , max. 0.62 Nm	
Approvals	UL: UL 508 listed; cUL: UL 60950-1 accepted; TÜV: EN 60950-1, CE: EN 61000-6-3 / EN 55022 Class B, EN 61000-3-2, EN 61000-3-3, EN 61000-6-2, EN 55024	

Monitoring		
DC ON Control (Rdy)	Normally open	–
Switching voltage	DC 60 V	–
Switching current	max. 300 mA	–
Switching capacity	–	–
Insulation voltage	DC 500 V	–

# Power supply - regulated, 960 W, 3-phase

## Primary switchmode power supply, PFC, 3-phase

Input: Wide range input AC 340 - 550 V

Output: 24 V / 48 V / 72 V



### Dimensions

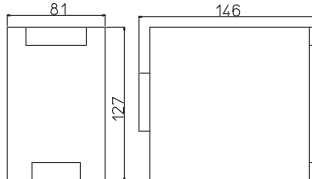

### PIN assignment

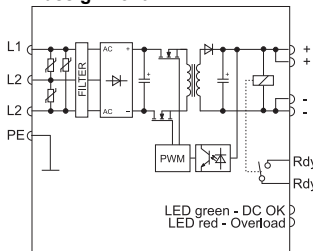

### Derating

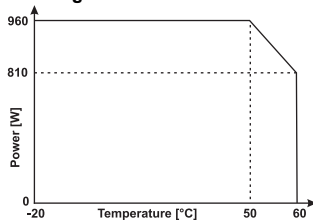

### Redundant operation

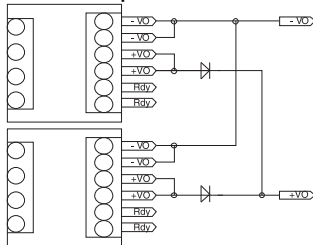

Description	Part-No.	Type	PU	
<b>Screw terminal</b>				
Output voltage/current	DC 24 V; 40 A	722811	CPSB3-960-24	1
	DC 48 V; 20 A	722812	CPSB3-960-48	1
	DC 72 V; 13.3 A	722813	CPSB3-960-72	1
<b>Input</b>				
	<b>CPSB3-960-24</b>	<b>CPSB3-960-48</b>	<b>CPSB3-960-72</b>	
Nominal voltage		3× AC 400–500 V		
Operation voltage range		3× AC 340–550 V		
Line frequency		47 – 63 Hz		
Rated current		U <sub>I</sub> = AC 400 V: 2.8 A / U <sub>I</sub> = AC 500 V: 2.2 A		
Inrush current		<AC 10 A		
Internal fuse		–		
External fuse		Mini-circuit breaker: 3× B 16 A, C 10 A		
Power Factor Correction P.F.C.		>0.6		
<b>Output</b>				
Rated voltage output	DC 24 V	DC 48 V	DC 72 V	
Rated current output	40 A	20 A	13.3 A	
Max. output current	>56 A, 5 s, @ 24 V	>28 A, 5 s, @ 48 V	>18.6 A, 5 s, @ 72 V	
Short-circuit current	>90 A, 5 s	>70 A, 5 s	>40 A, 5 s	
Voltage trim range	24/28 V	45/55 V	72/84 V	
Accuracy			–	
Line regulation			–	
Load regulation	<2 %	<1.5 %	<1 %	
Rise time			–	
Temperature coefficient			–	
Ripple & Noise			<100 mV	
Hold up time			>10 ms (AC 400 V); >15 ms (AC 500 V)	
Status indication DC ON LED green	≥21.6 V	≥43.2 V	≥64.8 V	
Status indication DC LOW LED red	≤21.6 V	≤43.2 V	≤64.8 V	
Parallel/redundant operation		max. 2 devices / via external diodes		
Efficiency		>94 %		
Low power loss		<61 W		
Rated over load protection		> 90°C, auto-reset		
Over voltage protection	<33 V	<60 V	<94 V	
Short circuit characteristics		Hiccup mode, 5 s ON / 10 s OFF		
<b>General</b>				
Switching frequency		approx. 70 – 110 kHz		
Insulation voltage input/output		AC 3.0 kV <sub>eff</sub>		
Insulation voltage input / ground		AC 2.0 kV <sub>eff</sub>		
Insulation voltage output / ground		AC 1.0 kV <sub>eff</sub>		
Insulation resistance at DC 500 V		– MΩ		
Operation temperature range		–20 °C – 60 °C (derating)		
Derating		>50°C: –15 W / °C, UL 508: >45°C: –15 W / °C		
Storage temperature range		–25 °C – 85 °C		
M.T.B.F.		>500000 h to SN29500 / >150000 h to MIL standard HDBK 217F		
Relative humidity		20–90% RH, non-condensing		
Dimensions (w × h × d) in mm		81.0 × 127.0 × 146.0		
Cooling		Natural air cooling, forced cooling >50°C, 50 mm distance above/below		
Housing material		Aluminium		
Field installation		rail TS 35 (EN 50022)		
Application height		– m		
Installation position		vertical		
Protection class		IP 20 (IEC529, EN60529)		
IP rating		I (SELV, PELV)		
Overvoltage category		II		
Pollution degree		2		
Weight (kg/piece)		1.200		
Termination		Screw terminal: 0.2–6.0 mm <sup>2</sup> , max. 0.62 Nm		
Approvals		UL, cUL: UL 508, IEC 950, EN 60950 CE: EN 61000-4-2/3/4/5/6/11, EN 61000-6-2, EN 601000-6-4, EN 50178, EN 61558, EN 50081-1, EN 50082-2, EN 55022 Class B		
<b>Monitoring</b>				
DC ON Control (Rdy)		Normally open		
Switching voltage		AC 300 V / DC 150 V		
Switching current		AC/DC 1 A		
Switching capacity		300 VA / 30 W		
Insulation voltage		AC 500 V		

# Power supply - Redundant module

## Redundant module 20 A with 2 inputs Potential-free signalling contact and Status LED per input Over- and undervoltage control



### Dimensions

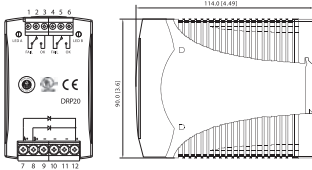

### PIN assignment

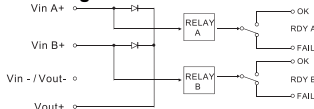

### Use

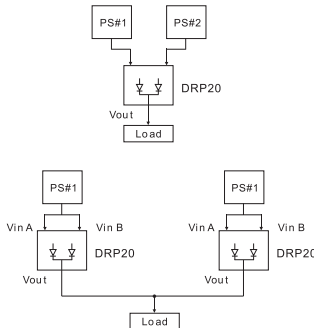

Description	Part-No.	Type	PU
<b>Screw terminal</b>			
Output voltage/current	DC 24 V; 20 A	722987	DRP 20-24
<b>Input</b>			
<b>DRP 20-24</b>			
Nominal voltage	DC 24 V		
Operation voltage range	DC 21–28 V		
Inputs	2		
Rated current	max. 20 A in total		
Internal fuse	–		
External fuse	–		
<b>Output</b>			
Rated voltage output	DC 24 V		
Rated current output	20 A		
Max. output current	30 A, 5 s, @ 24 V		
Voltage drop	0.5 V		
Inverse voltage	30 V		
Low power loss	Max. 10 W		
Status indication DC ON LED green	ON: DC input A or B OK / OFF: Error		
Rated over load protection	No		
Over voltage protection	No		
<b>General</b>			
Operation temperature range	-5°C – 70 °C		
Derating	–		
Storage temperature range	-25 °C – 85 °C		
M.T.B.F.	659000 h		
Dimensions (w × h × d) in mm	54.0 × 90.0 × 114.0		
Cooling	Air convection		
Housing material	Plastic		
Field installation	rail TS 35 (EN 50022)		
Application height	4850 m		
Installation postition	vertical		
Protection class	IP 20 (IEC529, EN60529)		
Overvoltage category	II		
Pollution degree	2		
Weight (kg/piece)	0.210		
Termination	Input: screw terminal: 0.2-4.0 mm <sup>2</sup> Output: screw terminal: 0.2-6.0 mm <sup>2</sup> Relay: screw terminal: 0.2-2.5 mm <sup>2</sup>		
Approvals	UL, cUL: UL 508 listed, UL 60950-1 recognized CE: EN 550 22 Class B, EN 55024 CE: EN 61000-4-2/3/4/6/8, EN 61204-3		
<b>Monitoring</b>			
DC ON Control (Rdy)	Changeover contact per input No error: input voltage >20 V or <30 V, connection 2(5) - 3(6) closed Error: input voltage <20 V or >30 V, connection 2(5) - 1(4) closed		
Switching voltage	AC 300 V / DC 150 V		
Switching current	AC/DC 1 A		
Switching capacity	300 VA / 30 W		
Insulation voltage	AC 100 V		

# Power supply · unregulated, 60–360 Watt

Power supply unit, Single-phase, unregulated, screw terminal  
 Input: AC 115 V / 230 V / 400 V  
 Output: DC 24 V



## Dimensions

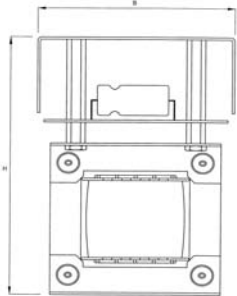

## PIN assignment

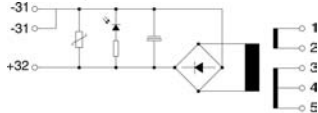

Voltage	Terminal	Contact bridge
115 V	1 u. 4	1 – 3 u. 2 – 4
230 V	1 u. 4	2 – 3
400 V	1 u. 5	2 – 3

Description	Part-No.	Type	PU	
<b>Screw terminal</b>				
Nominal voltage	DC 24V; 2.5A	722962	NG 24/2,5-2962	1
	DC 24 V; 5 A	722963	NG 24/5-2963	1
	DC 24 V; 10 A	722972	NG 24/10-2972	1
	DC 24 V; 15 A	722973	NG 24/15-2973	1

Input	NG 24/2,5-2962	NG 24/5-2963	NG 24/10-2972	NG 24/15-2973
Input voltage	AC 115 / 230 / 400 V			
Operation voltage range	AC 104–196 V / AC 207–224 V / AC 360–424 V			
Line frequency	47 – 63 Hz			
Rated current	1.6 A / 0.6 A / 0.4 A	2.4 A / 1.1 A / 0.6 A	5.0 A / 2.4 A / 1.8 A	6.0 A / 3.2 A / 2.0 A
Rated power	60 W	120 W	240 W	360 W
Recommended back-up fuse	115 V: 4 A / 230 V: 2 A / 400 V: 1 A	115 V: 4 A / 230 V: 2 A / 400 V: 2 A	115 V: 6 A / 230 V: 4 A / 400 V: 2 A	115 V: 10 A / 230 V: 6 A / 400 V: 4 A

Termination Screw terminal with additional flat connector: 0.5–6.0mm<sup>2</sup>

Output	DC 24 V			
Rated voltage output	DC 24 V			
Rated current output	2.5 A	5 A	10 A	15 A
Nominal voltage	at open-circuit 30.2 V, at full load: 20.4 V			
Line regulation	–			
Load regulation	–			
Transient recovery time	–			
Temperature coefficient	–			
Ripple	2.2–2.7 %		–	
Hold up time	–			
Status indication DC ON LED green	Yes			
Status indication DC LOW LED red	–			
Parallel/redundant operation	with 90% load current			
Efficiency	73 %	77 %	80 %	
Rated over load protection	No			
Short circuit characteristics	–			
Output circuit	Varistor and capacitor			
Termination	Screw terminal 0.5–10 mm2			

<b>General</b>				
Switching frequency	–			
Insulation voltage input/output	4.0 kV <sub>eff</sub>			
Insulation class	T 40 / B			
Insulation class	according to VDE B, UL/CSA: class 130			
Operation temperature range	–25 °C – 80 °C			
Derating	–			
Storage temperature range	–40 °C – 80 °C			
Relative humidity	80% occasional condensation possible			
Dimensions (w × h × d) in mm	85 × 137 × 98	106 × 160 × 113	121 × 170 × 128	151 × 200 × 145
Cooling	Air convection			
Housing material	metal			
Field installation	Screw termination: 0.5–4.0 mm <sup>2</sup>			
Assembly borehole	64 × 64.5 mm/M 5	83 × 80.5 mm/M 5	104 × 90 mm/M 5	90 × 122 mm/M 6
Cu application weight	0.62 kg/piece	0.6 kg/piece	0.9 kg/piece	1.5 kg/piece
Installation position	Optional			
Protection class	IP 00			
IP rating	I			
Weight (kg/piece)	2.300	4.900	7.500	9.000
Standards	Transformer compliant with IEC 61-558, Output limit values compliant with EN 61 131-2 EMC compliant with EN 50 081-1 and EN 50 082-2, Main connection compliant with EN 61 000-3-2			
Approvals	cULus			

## Fixing

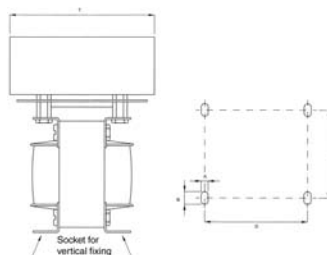

# Power supply · unregulated, 72–240 Watt

Power supply unit, Single-phase, unregulated, screw terminal

Input: AC 230 V / 400 V

Output: DC 24 V



## Dimensions

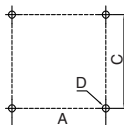
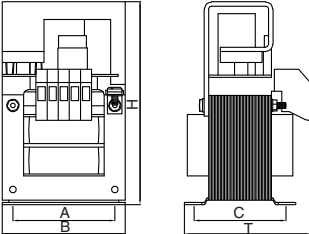

## PIN assignment

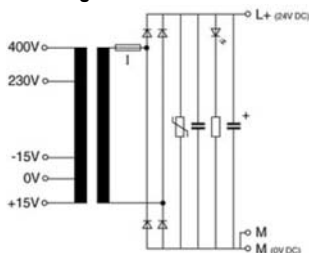

Description	Part-No.	Type	PU
<b>Screw terminal</b>			
Nominal voltage	722620	NG 24/3-2620 with fusing	1
	722621	NG 24/36-2621 with fusing	1
	722622	NG 24/10-2622 with fusing	1
<b>Input</b>			
	<b>NG 24/3-2620 with fusing</b>	<b>NG 24/36-2621 with fusing</b>	<b>NG 24/10-2622 with fusing</b>
Input voltage	AC 230 / 400 V		
Operation voltage range	AC 207–244 V / AC 360–424 V		
Line frequency	47 – 63 Hz		
Rated current	0.7 A / 0.5 A	1.2 A / 0.8 A	2.4 A / 1.6 A
Rated power	72 W	144 W	240 W
Recommended back-up fuse	2 A / 1 A	2 A / 2 A	4 A / 2 A
Termination	Screw terminal with additional flat connector: 0.5–6.0 mm <sup>2</sup>		
<b>Output</b>			
Rated voltage output	–		
Rated current output	3 A	6 A	10 A
Nominal voltage	at open-circuit 30.2 V, at full load: 20.4 V		
Line regulation	–		
Load regulation	–		
Transient recovery time	–		
Temperature coefficient	–		
Ripple	< 5%		
Hold up time	–		
Status indication DC ON LED green	Yes		
Status indication DC LOW LED red	–		
Parallel/redundant operation	with 90% load current		
Efficiency	77 %		
Rated over load protection	yes		
Short circuit characteristics	–		
Output circuit	Varistor and capacitor		
Termination	Screw terminal: 0.5–4.0 mm <sup>2</sup>		
<b>General</b>			
Switching frequency	–		
Insulation voltage input/output	4.0 kV <sub>eff</sub>		
Insulation class	T 40 / B		
Insulation class	according to VDE B, UL/CSA: class 130		
Operation temperature range	–25 °C – 80 °C		
Derating	–		
Storage temperature range	–40 °C – 80 °C		
Relative humidity	80% occasional condensation possible		
Dimensions (w × h × d) in mm	84 × 146 × 77	96 × 156 × 103	120 × 174 × 102
Cooling	Air convection		
Housing material	metal		
Field installation	Screw terminal: 0.5–4.0 mm <sup>2</sup>		
Assembly borehole	65 mm × 64 mm/M 4	86,5 mm × 84 mm/M 5	85 mm × 90 mm/M 5
Cu application weight	0.3 kg/piece	0.5 kg/piece	1 kg/piece
Installation position	Optional		
Protection class	IP 00		
IP rating	I		
Weight (kg/piece)	2.300	3.900	5.600
Standards	Transformer compliant with IEC 61-558, Output limit values compliant with EN 61 131-2 EMC compliant with EN 50 081-1 and EN 50 082-2, Main connection compliant with EN 61 000-3-2		
Approvals	cULus		

# LOCC-Box / LOCC-Box-Net • Overview

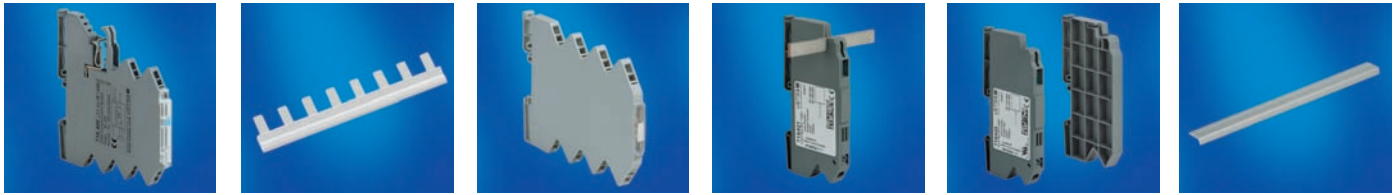

Current range	Characteristic		Status output			Remote input	Bus connection	Software	Gateway		Part-Nr.	
	10, adjustable in 1 A-steps 1 A - 10 A	5, fast / medium / slow-1 / slow-2 / slow-3	5, fast / medium / slow-1 / slow-2 / slow-3 + 1, programmable	active Low after Overload or short circuit	active Low after Overload or short circuit + man. Off				parametrizable	On- / Off via puls parametrizable		Yes
•	•		•			•						716400
•	•			•		•						716401
•		•			•	•	•	•	•	•	•	716410

Accessories			
Module	Part-Nr.	Type	PU
Gateway (USB, CANopen, RS232)	716459	LOCC-Box-GW 7-6459	1
Supply terminal with break out for copper bus bar, increase the input current	716421	LOCC-Box-EKL 7-6421	2
Supply terminal without terminal	716422	LOCC-Box-DKL 7-6422	2
LOCC-Box empty housing without terminals	716424	LOCC-Box-DY 7-6424	2
Supply set (supply & end terminal block)	716425	LOCC-Box-ES 7-6425	1
0V-Collecting Terminal	716420	LOCC-Box-SK 7-6420	2
Jumber Comb			
Part-Nr.	Type	PU	
716428	LOCC-Box-BKW 7-6428	5	
716429	LOCC-Box-BKR 7-6429	5	
716430	LOCC-Box-BKB 7-6430	5	
716438	LOCC-Box-BKW 7-6438	5	
716439	LOCC-Box-BKW 7-6439	5	
716440	LOCC-Box-BKW 7-6440	5	
Marker Holder			
Part-Nr.	Type	PU	
716431	LOCC-Box-BZW 7-6431	1	
716432	LOCC-Box-BZR 7-6432	1	
716433	LOCC-Box-BZB 7-6433	1	
716434	LOCC-Box-BZG 7-6434	1	
716441	LOCC-Box-BZW 7-6441	1	
Other			
Part-Nr.	Type	PU	
716426	LOCC-Box-CU 7-6426	1	
716427	LOCC-Box-AD 7-6427	1	

# Modular, flexible and safe: LOC C-Box / LOCC-Box-Net

## The intelligent LÜTZE Overload Current Control System

Adjustable rated current (1A – 10A)

Adjustable characteristic  
(fast- ... slow acting)

“Power-ON”-effect to switch  
on capacitive loads

Single or centralized fault indication

Non-volatile store of the last status

Spring terminals

Small device – width 8,1mm

Response time independent  
of temperature

Contact slots for each potential usable  
for jumper combs

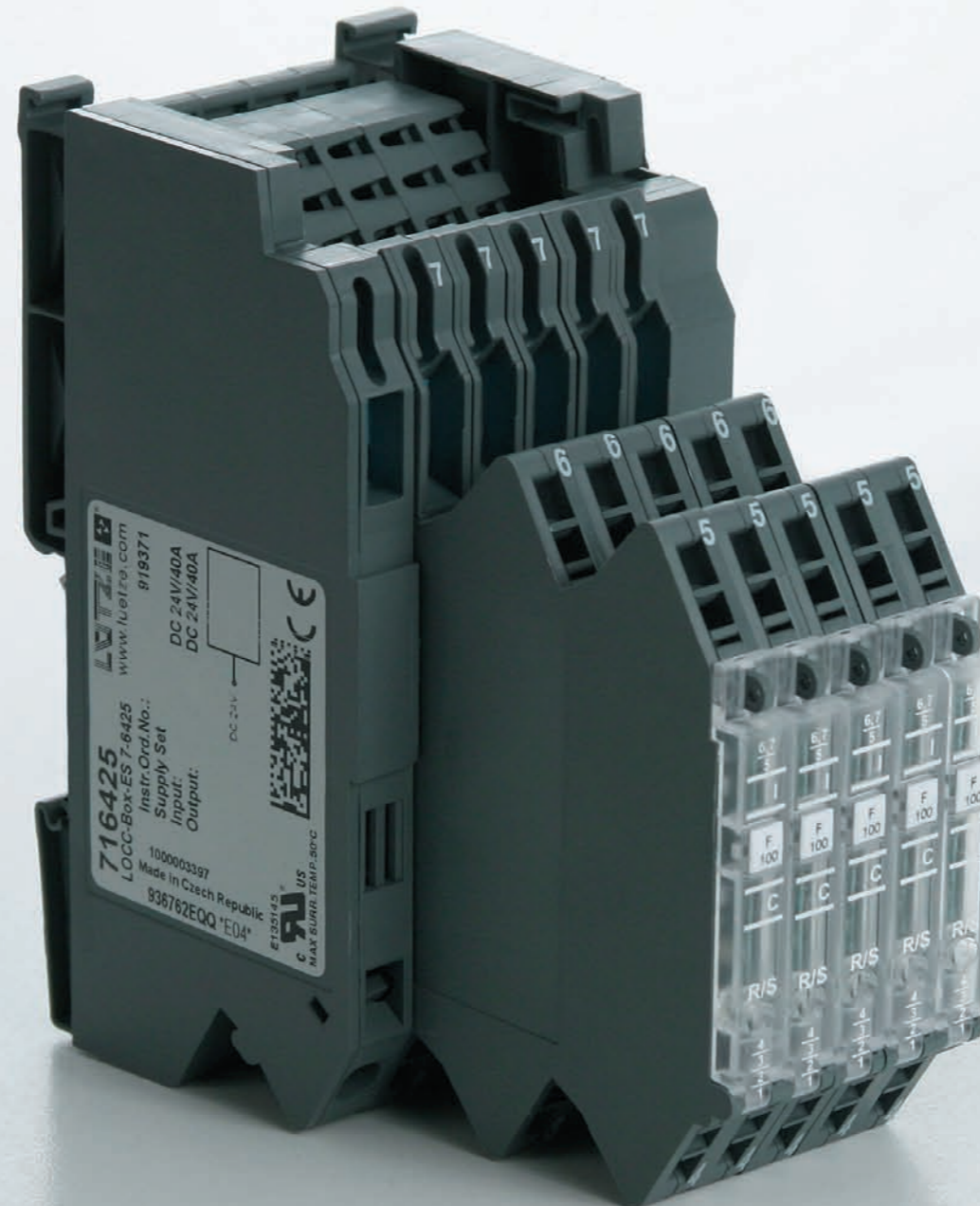

Remote ON / OFF

Manual ON / OFF

Status indication  
“operation”, “fault”, “90% load”  
and “100% load”

Adjustments can be sealed  
by standard seal wire

flammability class UL-94-V0;  
NFF I2,F2

Uninterruptible supply via Copper  
bar and contact slide

Option: One wire bus interface  
(716410)

UL 508

The picture shows 5 x LOCC Box incl. Supply Set



# LOCC-Box / LOCC-Box-Net • Example Application

## Standard Application

without supply set, art. no. 716425

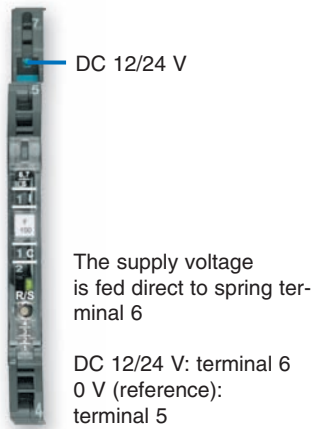

with supply set, art. no. 716425

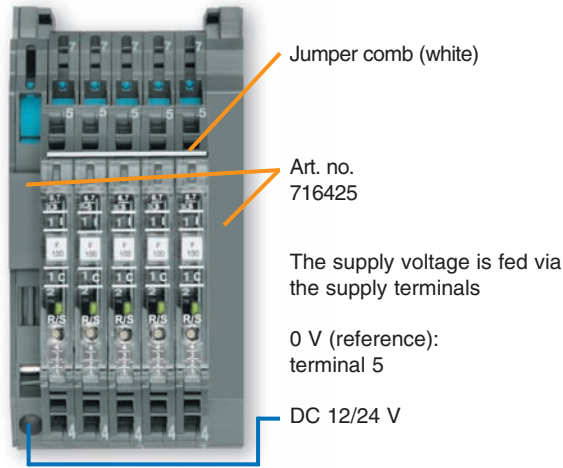

## Use with additional supply terminals

Supply set, art. no. 716425 and supply terminal, art. no. 716421

The supply terminal is accessed via an aperture in the left hand side wall. This enables a variable positioning in the system construction. The maximum total current can thus be increased to 70 A.

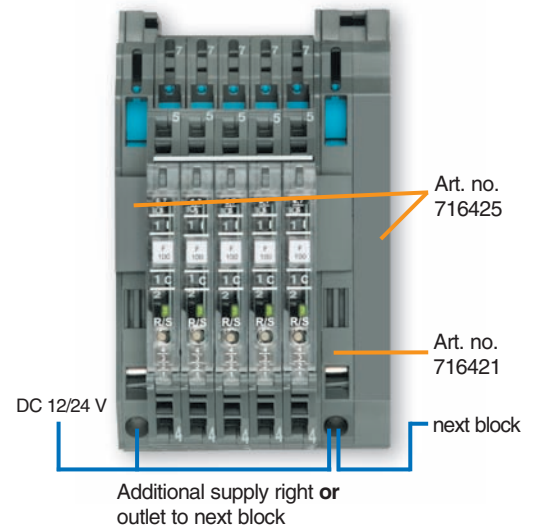

## Individual construction with distance terminal

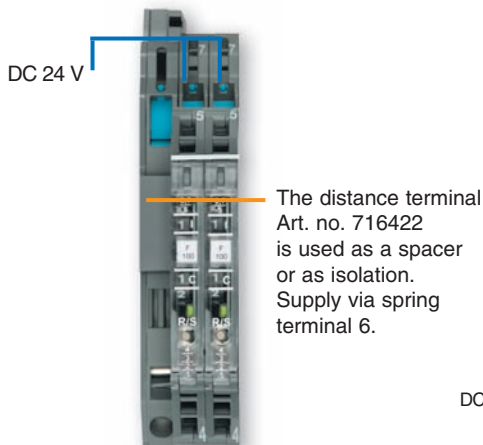

## Empty housing as placeholder

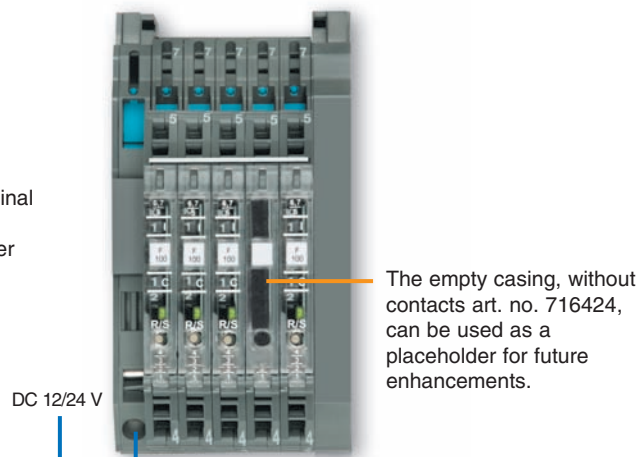

# LOCC-Box / LOCC-Box-Net • Example Application

## 0V Collective Terminal

The 0V collective terminal 716420 enables the 0V return from the load to the 0V supply in the tightest space. The integrated sliding contact enables an insulation measurement when the contact is open.



## Power Supply

e.g. art. no. 722805  
24 V/20 A

## Standard Application

with supply set, art. no. 716425

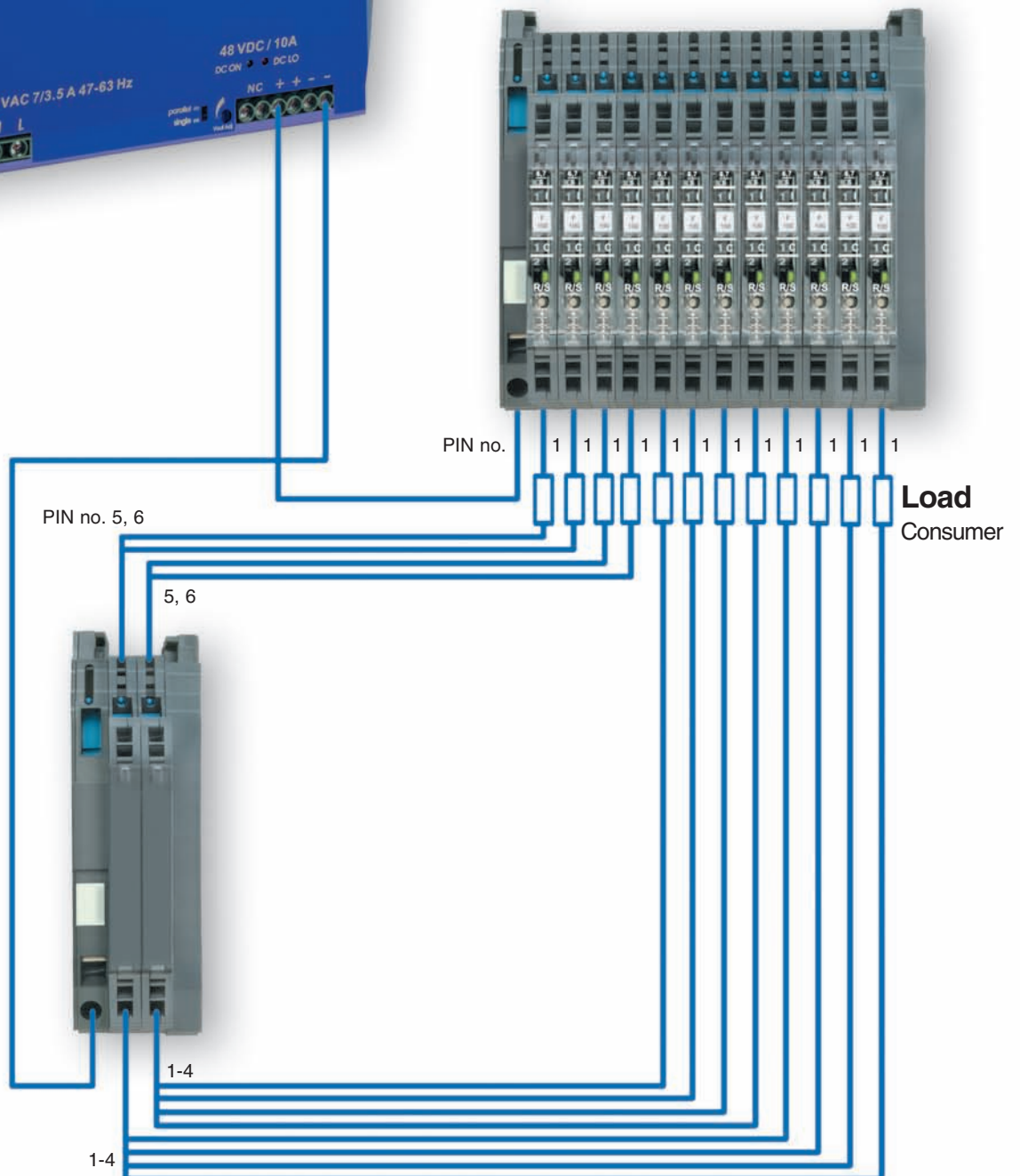

## Construction of the 0V Collective terminal

with supply set  
Art. no. 716425

# Load monitoring · Microcompact LOCC Box

Electronic load monitoring up to DC 10 A  
 Single-channel design, Adjustable current range: DC 1 A – 10 A  
 Adjustable characteristics, fast, medium-speed, slow 1, -2, -3



## Dimensions

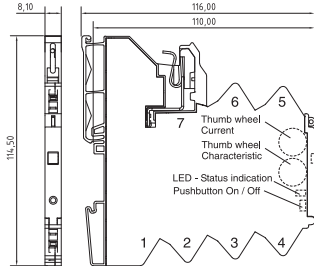

## PIN assignment

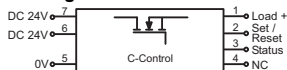

- 1: + Output
- 2: Control input (Set/Reset)
- 3: Status output
- 4: NC
- 5: 0V
- 6: + Supply (alternative)
- 7: + Supply

Description	Part-No.	Type	PU	
<b>Spring terminal</b>				
Nominal voltage	DC 12 / 24 V	716400	LOCC-Box-FB 7-6400	1
	DC 12 / 24 V	716401	LOCC-Box-FB 7-6401	1

Input	LOCC-Box-FB 7-6400	LOCC-Box-FB 7-6401
Nominal voltage	DC 12 / 24 V	DC 12 / 24 V
Operation voltage range	DC 10 V – 32 V	
Rated current	DC 10 A	
Supply current	DC 40 A over Cu-rails 10 × 3 mm	
Reverse voltage protection	internal electronics	
Termination	screwless disconnect slide	
<b>Control input (Set / Reset)</b>		
Signal level	DC 12 / 24 V (EN 61131)	
Fall time	Pulse with falling edge >100 ms, <800 ms	
Rise time	Pulse with falling edge > 1 s	
Connection	Spring terminal 0.25–2.5 mm <sup>2</sup>	
<b>Output</b>		
Switching element	MosFet	
Output current	max. DC 10 A	
Voltage drop	<170 mV (10 A)	
Status Indication	LED green: Operating voltage present, no error LED red: Error in load circuit	
Switch-on capacity	10000 µF	
Current range	1 A – 10 A (adjustable via switch in 1 A steps)	
Characteristic	fast-acting (1), medium-slow (2), slow 1 (3), slow 2 (4), slow 3 (5)	

Signal output	LOCC-Box-FB 7-6400	LOCC-Box-FB 7-6401
Signal level	DC 12/24 V: Operating voltage present, no error; DC 0 V: error, output switched off	DC 12/24 V: Operating voltage present, no error; DC 0 V: error, output switched off and manual "OFF"
Switching element	Transistor, collector with pull-up resistance	

General	
Housing material	PA 6.6 (UL 94-V0; NFF I2, F2)
Field installation	rail TS 35 (EN 50022)
Protection class	IP 20
Installation position	Optional
Termination	Spring terminal 0.25–2.5 mm <sup>2</sup>
Operation temperature range	-25 °C – 50 °C
Storage temperature range	-40 – 85 °C
Dimensions (w × h × d) in mm	8.1 × 114.5 × 116.0
Weight (kg/piece)	0.120
Approvals	cURus
Standards	EN 60950-1; EN 61131-1,2; EN 61000; EN 60947-4-1; EN 55022

Accessories	Colour	Article number	Description	PU
Feed in set (feed in terminal and end terminal), 10 mm <sup>2</sup>		716425	LOCC Box ES 7-6425	1
Copper bus bar 1m		716426	LOCC Box CU 7-6426	1
Cu rail covering 1 m		716427	LOCC Box AD 7-6427	1
Jumper comb 8 pole, 6A	white	716428	LOCC Box BKW 7-6428	5
Jumper comb 8 pole, 6A	red	716429	LOCC Box BKR 7-6429	5
Jumper comb 8 pole, 6A	blue	716430	LOCC Box BKB 7-6430	5
Jumper comb 16-pole, 6 A	white	716438	LOCC Box BKW 7-6438	5
Jumper comb 16-pole, 6 A	red	716439	LOCC Box BKR 7-6439	5
Jumper comb 16-pole, 6 A	blue	716440	LOCC Box BKB 7-6440	5
Marker holder (200 pcs.)	white	716431	LOCC Box BZW 7-6431	1
Marker holder (200 pcs.)	red	716432	LOCC Box BZR 7-6432	1
Marker holder (200 pcs.)	blue	716433	LOCC Box BZB 7-6433	1
Marker holder (200 pcs.)	yellow	716434	LOCC Box BZG 7-6434	1

## Signal output

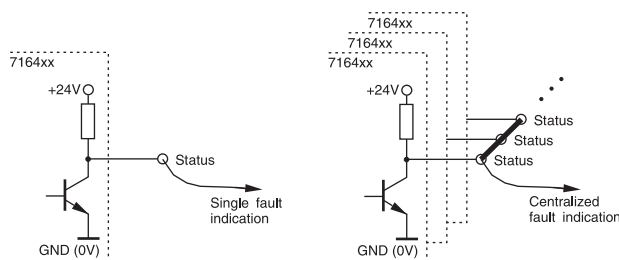

# Load monitoring · Microcompact LOCC-Box-Net

Electronic load monitoring up to DC 10 A, with communication  
 Single-channel design, programmable, Adjustable current range: DC 1 A – 10 A  
 Adjustable characteristics, fast, medium-speed, slow 1, -2, -3



## Dimensions

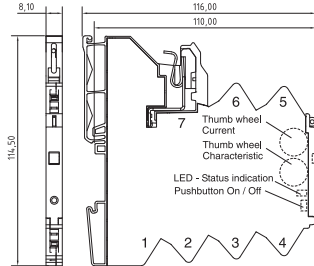

## PIN assignment

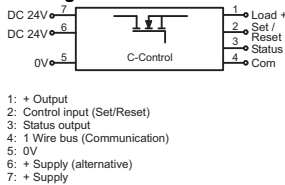

Description	Part-No.	Type	PU
<b>Spring terminal</b>			
Nominal voltage	DC 12 / 24 V	716410	LOCC-Box-Net 7-6410
<b>Input</b>			
<b>LOCC-Box-Net 7-6410</b>			
Nominal voltage	DC 12 / 24 V		
Operation voltage range	DC 10 V – 32 V		
Rated current	DC 10 A		
Supply current	DC 40 A over Cu rail 10 × 3 mm		
Reverse voltage protection	internal electronics		
Termination	screwless disconnect slide		
<b>Control input (Set / Reset)</b>			
Signal level	DC 12 / 24 V (EN 61131)		
Fall time	Pulse with falling edge >100 ms, <800 ms		
Rise time	Pulse with falling edge > 1 s		
Connection	Spring terminal 0.25–2.5 mm <sup>2</sup>		
<b>Output</b>			
Switching element	MosFet		
Output current	max. DC 10 A		
Voltage drop	<170 mV (10 A)		
Status Indication	LED green: Operating voltage present, no error LED red: Error in load circuit		
Switch-on capacity	10000 µF		
Current range	1 A – 10 A (adjustable via switch in 1 A steps)		
Characteristic	fast-acting (1), medium-slow (2), slow 1 (3), slow 2 (4), slow 3 (5), programmable (10)		
<b>Signal output</b>			
Signal level	DC 12/24 V: Operating voltage present, no error; DC 0 V: error, output switched off, programmable		
Switching element	Transistor, collector with pull-up resistance		
<b>General</b>			
Housing material	PA 6.6 (UL 94-V0; NFF I2, F2)		
Field installation	rail TS 35 (EN 50022)		
Protection class	IP 20		
Installation position	Optional		
Termination	Spring terminal 0.25–2.5 mm <sup>2</sup>		
Operation temperature range	-25 °C – 50 °C		
Storage temperature range	-40 – 85 °C		
Dimensions (w × h × d) in mm	8.1 × 114.5 × 116.0		
Weight (kg/piece)	0.120		
Approvals	cURus		
Standards	EN 60950-1; EN 61131-1,2; EN 61000; EN 60947-4-1; EN 55022		
<b>Accessories</b>	<b>Colour</b>	<b>Article number</b>	<b>Description</b>
Gateway on USB, CANopen, RS232		716459	LOCC Box GW 7-6459
Feed in set (feed in terminal and end terminal), 10 mm <sup>2</sup>		716425	LOCC Box ES 7-6425
Copper bus bar 1m		716426	LOCC Box CU 7-6426
Cu rail covering 1 m		716427	LOCC Box AD 7-6427
Jumper comb 8 pole, 6A	white	716428	LOCC Box BKW 7-6428
Jumper comb 8 pole, 6A	red	716429	LOCC Box BKR 7-6429
Jumper comb 8 pole, 6A	blue	716430	LOCC Box BKB 7-6430
Jumper comb 16-pole, 6 A	white	716438	LOCC Box BKW 7-6438
Jumper comb 16-pole, 6 A	red	716439	LOCC Box BKR 7-6439
Jumper comb 16-pole, 6 A	blue	716440	LOCC Box BKB 7-6440
Marker holder (200 pcs.)	white	716431	LOCC Box BZW 7-6431
Marker holder (200 pcs.)	red	716432	LOCC Box BZR 7-6432
Marker holder (200 pcs.)	blue	716433	LOCC Box BZB 7-6433
Marker holder (200 pcs.)	yellow	716434	LOCC Box BZG 7-6434

## Signal output

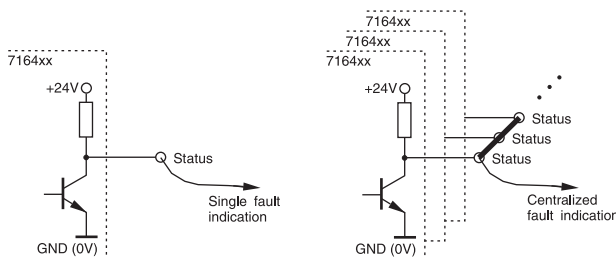

# Load monitoring · Microcompact Gateway

## Gateway for LOCC-Box-Net (716410)

Input: LOCCbus (LIN)

Output: USB, RS 232, CANopen



### Dimensions

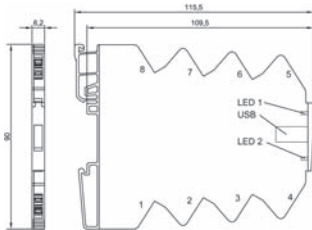

### PIN assignment

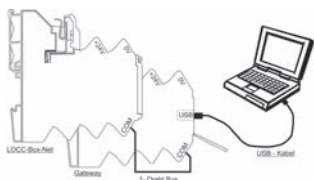
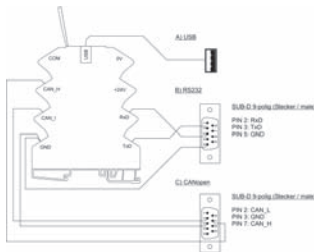

Description	Part-No.	Type	PU
<b>Spring terminal</b>			
Nominal voltage	DC 12 / 24 V	716459	LOCC-Box-GW 7-6459
			1
<b>Input</b>			
<b>LOCC-Box-GW 7-6459</b>			
Bus system	LOCCbus, basic LIN		
Access method	Single-Master - Multiple Slave		
Bus technology	Line		
Physical level	1-wire		
Participants	40, max. 254		
Bus length	max. 40 m		
Transfer rate	9600 Baud		
Data rate	8 Bit + fixed parity		
Transfer protocol	Modified multi-drop		
<b>Output</b>			
Bus system	<b>USB</b>	<b>RS232</b>	<b>CANopen</b>
Transfer rate	USB 2.0 Full-Speed	RS232	CANopen
	12 Mbit/s	600 – 11500 bit/s	10 – 1000 kbit/s
<b>General</b>			
Nominal voltage	DC 12 / 24 V		
Operation voltage range	DC 10 V – 26.4 V		
Rated current	max. 50 mA		
Reverse voltage protection	Yes		
Status Indication	LED 1 green/red: USB, RS232, Firmware; LED 2 green/red: CANopen		
Insulation voltage	1.0 kV		
Housing material	PA 6.6 (UL 94-V0; NFF I2, F2)		
Field installation	rail TS 35 (EN 50022)		
Protection class	IP 20		
Installation position	Optional		
Termination	Spring terminal : 0.14 - 2.5 mm <sup>2</sup> (with AE 1.5 mm <sup>2</sup> )		
Operation temperature range	-20 °C – 60 °C		
Storage temperature range	-40 – 85 °C		
Dimensions (w × h × d) in mm	6.2 × 90.0 × 115.0		
Weight (kg/piece)	0.060		
Approvals	CE		
Standards	EN 60950-1; EN 61131-1,2; EN 60898; EN 60947-4-1; EN 50081		
<b>Accessories</b>			
Tag holder 4×11 mm	Colour	Article number	Type
	white	681313	BZT 0411
Isolation plate		760809	TP 7-0809
Labels for laser printer A4 unpunched		681031	LEB - A4
Labels for laser printer 4.23 x 11 mm (Sheet with 1056 labels)		681034	LEB 0411
			1

# LOCC-Box / LOCC-Box-Net • Characteristic Curves

All device variants incorporate the same characteristics

Extensible

Customer specific characteristics - parameterisable with LOCC-Box-Net

Switch position 1: Characteristic fast

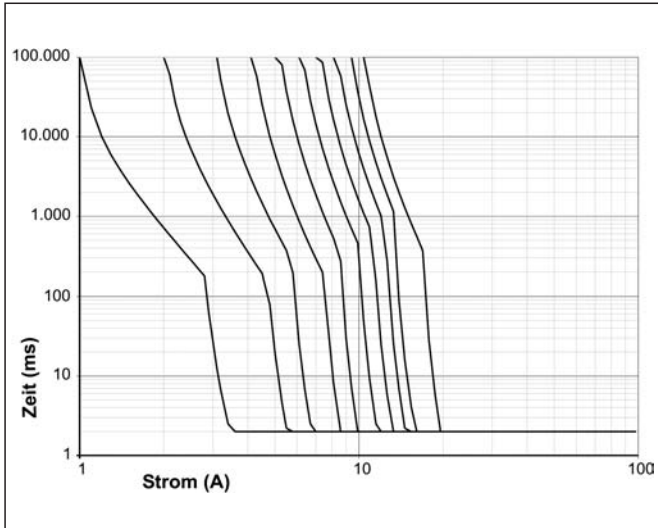

Switch position 2: Characteristic medium

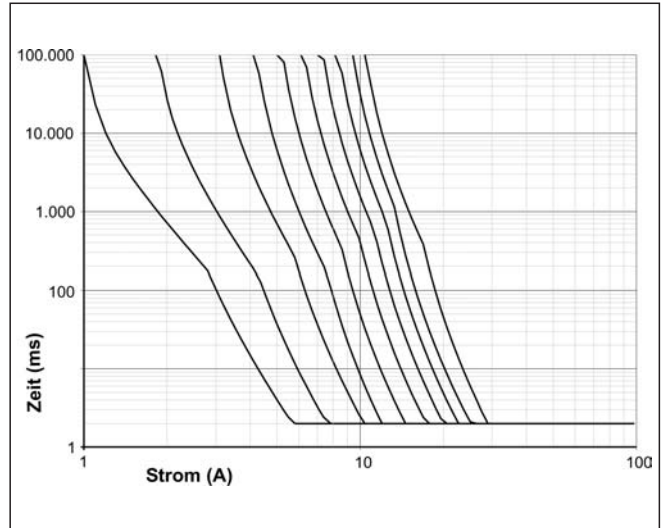

Switch position 3: Characteristic slow-1

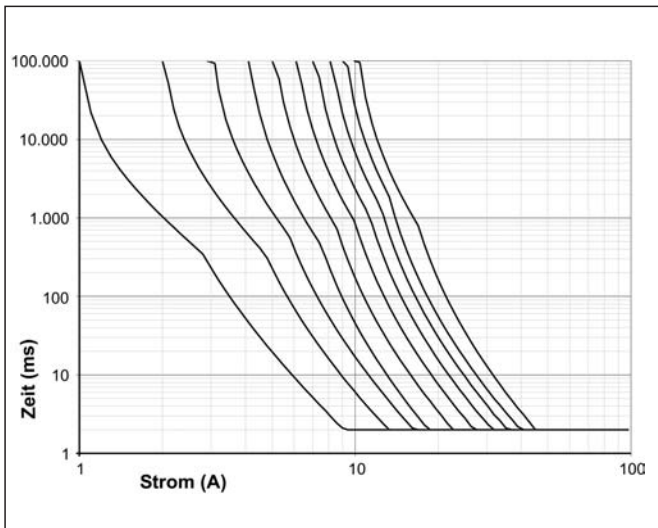

Switch position 4: Characteristic slow-2

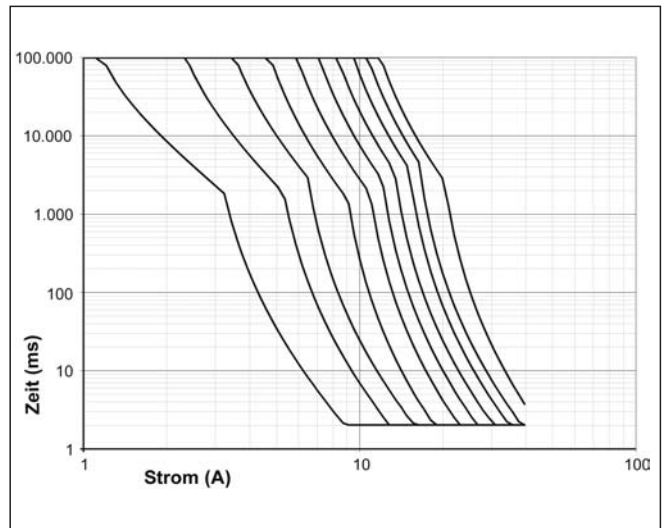

Switch position 5: Characteristic slow-3

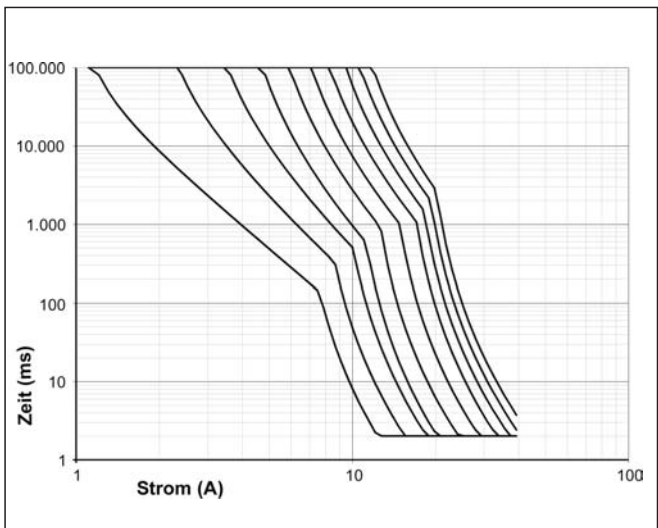

# Load monitoring · Accessories

## LOCC Box supply set consisting of supply terminal and end block maximum total current 40 A



### Dimensions

Supply terminal

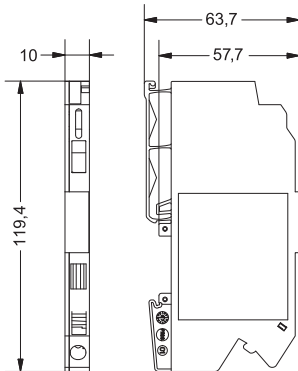

End block

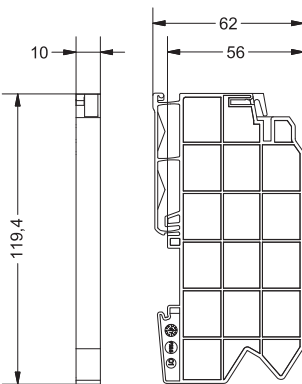

Description	Part-No.	Type	PU	
Nominal voltage	DC 12 / 24 V	716425	LOCC-Box-ES 7-6425	1
<b>Input</b>				
<b>LOCC-Box-ES 7-6425</b>				
Nominal voltage	DC 12 / 24 V			
Rated current	max. DC 40 A			
Reverse voltage protection	No			
Termination	Spring terminal : 0.33 – 10 mm <sup>2</sup> (AWG 22–8) conductor connection cross section, single wire (solid): max. 10 mm <sup>2</sup> conductor connection cross section, fine wire: max. 6 mm <sup>2</sup> conductor connection cross section, fine wire with AEH: max. 6 mm <sup>2</sup>			
Length of stripped insulation	12 mm			
<b>Output</b>				
Nominal voltage	DC 12 / 24 V			
Output current	max. DC 40 A			
Termination	screwless disconnect slit			
Copper bus bar	3 × 10mm			
<b>General</b>				
Housing material	PA 6.6 (UL 94-V0; NFF I2, F2)			
Field installation	rail TS 35 (EN 50022)			
Protection class	IP 20			
Installation position	Optional			
Operation temperature range	-25 °C – 60 °C			
Storage temperature range	-40 – 85 °C			
Dimensions (w × h × d) in mm	10.0 × 119.4 × 63.7			
Weight (kg/piece)	0.035			
Approvals	cURus			
Standards	–			

# Load monitoring - Accessories

## LOCC Box supply terminal Break out for copper bus bar for increased current maximum total current 40 A



### Dimensions

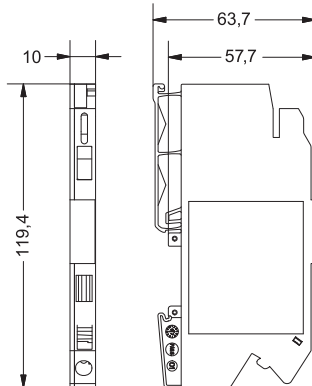

### Use



716421

Description	Part-No.	Type	PU	
Nominal voltage	DC 12 / 24 V	716421	LOCC-Box-EKL 7-6421	2
<b>Input</b>				
<b>LOCC-Box-EKL 7-6421</b>				
Nominal voltage	DC 12 / 24 V			
Rated current	max. DC 40 A			
Reverse voltage protection	No			
Termination	Spring terminal : 0.33 – 10 mm <sup>2</sup> (AWG 22–8) conductor connection cross section, single wire (solid): max. 10 mm <sup>2</sup> conductor connection cross section, fine wire: max. 6 mm <sup>2</sup> conductor connection cross section, fine wire with AEH: max. 6 mm <sup>2</sup>			
Length of stripped insulation	12 mm			
<b>Output</b>				
Nominal voltage	DC 12 / 24 V			
Output current	max. DC 40 A			
Termination	screwless disconnect slit			
Copper bus bar	3 × 10mm			
<b>General</b>				
Housing material	PA 6.6 (UL 94-V0; NFF I2, F2)			
Field installation	rail TS 35 (EN 50022)			
Protection class	IP 20			
Installation position	Optional			
Operation temperature range	-25 °C – 60 °C			
Storage temperature range	-40 – 85 °C			
Dimensions (w × h × d) in mm	10.0 × 199.4 × 63.7			
Weight (kg/piece)	0.035			
Approvals	cURus			
Standards	–			



# Load monitoring · Accessories

## 0V Collective Terminal Single-channel design maximum total current 40 A



### Dimensions

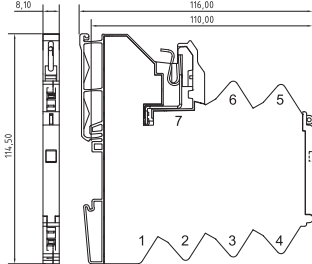

### PIN assignment

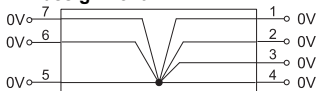

Description	Part-No.	Type	PU	
Nominal voltage	DC 12 / 24 V	716420	LOCC-Box-SK 7-6420	2
<b>Input</b>		<b>LOCC-Box-SK 7-6420</b>		
Nominal voltage	DC 12 / 24 V			
Rated current	6× max. DC 10 A			
Reverse voltage protection	No			
Termination	Spring terminal: 0.25–2.5 mm <sup>2</sup>			
Connection	1 – 6			
<b>Output</b>				
Output current	max. DC 40 A			
Voltage drop	–			
Termination	screwless disconnect slit			
Connection	7			
<b>General</b>				
Housing material	PA 6.6 (UL 94-V0; NFF I2, F2)			
Field installation	rail TS 35 (EN 50022)			
Protection class	IP 20			
Installation position	Optional			
Operation temperature range	-25 °C – 60 °C			
Storage temperature range	-40 – 85 °C			
Dimensions (w × h × d) in mm	8.1 × 114.5 × 116.0			
Weight (kg/piece)	0.700			
Approvals	–			
Standards	–			

# Uninterruptible Power Supply (USP)



No. 1



No. 2



No. 3

## DC - USP

Power			Input		Functions			Output			Characteristics					Part-No.	Type	Page	No.
250 W	500 W	1000 W	AC 120 V/230 V (85 ... 276 V)	DC 24 V (22 ... 30 V)	Internal Power Supplies	Charging	Batterie monitoring	24 V / 10 A	24 V / 20 A	24 V / 40 A	ACS Charge	I-Uo-U-Charge	Temperature monitoring	external Batterie	Status LED / Relais				
•				•		•	•	•	•			•	•	•	•	723001	L-COPS-B1-BME-250-24	56	1
	•			•		•	•		•			•	•	•	•	723002	L-COPS-B1-BME-500-24	58	1
		•		•		•	•			•		•	•	•	•	723004	L-COPS-B1-BME-1000-24	60	1
•			•		•	•	•	•	•			•	•	•	•	723011	L-COPS-B1-BM-250-24	62	2
	•		•		•	•	•		•			•	•	•	•	723012	L-COPS-B1-BM-500-24	64	2
		•	•		•	•	•			•		•	•	•	•	723014	L-COPS-B1-BM-1000-24	66	2

## Battery

Power		Dimensions WxHxD		Internal fuse		Connection Cable			Type of battery		Part-No.	Type	Page	No.
7Ah @ 24V	14Ah @ 24V	176x 135x 170	306x 124x 185	25A / 32V	2x 25A / 32V	Length m	Diameter mm <sup>2</sup>	Color	AGM					
•		•		•		1,5	4	rt/sw	•		723020	L-BPT24-7AH	68	3
	•		•		•	1,5	4	rt/sw	•		723022	L-BPT24-14AH	68	4

# Patented Battery Charging- and Diagnostic Procedure

## Intelligent UPS-Battery Management Systems Power Excellent

### Patent protected, adaptive procedure

real algorithms, no internal access to any battery characteristics on a database

### Thermal management

prevents the thermal "run-away" of the battery

### Dynamic adaption

of the charging parameters in relation to the temperature as well as the charge (SOC) and ageing status (SOH) of the battery

### Charge factor<sup>1)</sup> until 1,02

(customary values are typ. 1,10-1,20)

### Reduction of the yearly energy consumption by typically a factor of 10

(compared with conventional procedures)

1) Charge factor  $\kappa$  :

\* Describes the ratio between the energy used during charging and the actual charge absorbed by the battery

\* Charge factor  $\kappa$  is the reciprocal of the charging efficiency  $\eta$

$$\text{Charge factor } \kappa = 1/\eta$$



**Patent protected, temperature compensated diagnostic procedure**  
for ageing determination (SOH = State-Of-Health) of lead-based UPS batteries

**Regeneration**  
of aged (sulphated) cells

**No serial effects**  
D-IPS ACS maintains the battery capacity (high cycle consistency)

**Fast charging capability**  
without detrimental consequences for the battery

**No permanently connected charging voltage**

# ACS- Temperature Compensated Battery Charging and I

## Main Charging Phase:

- the *CONSTANT CURRENT CHARGING* enables an ideal quick charging of the battery with high charging current and relatively low temperature compensated charging voltage (far below the gassing voltage).
- *ADAPTIVE CURRENT STEP CHARGING PROCEDURE*: Immediately the algorithm detects the onset of secondary reactions in a relevant magnitude, the next constant current charging step is activated.
- according to the ascertained battery parameters the procedure is repeated until the lead-acid battery is nearly charged.

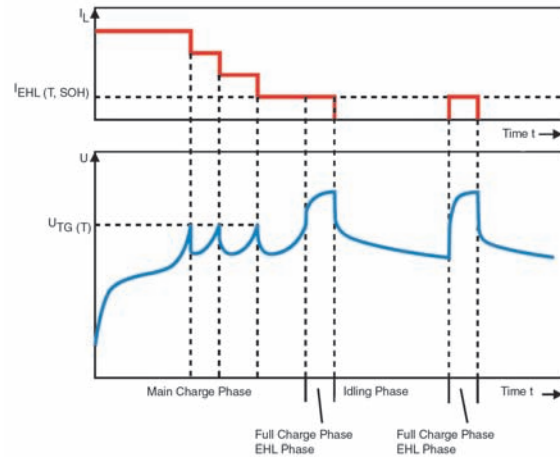

## Full Charging Phase / No-Load Phase:

- at the end of the charging process there follows a short *FULL CHARGE / TRICKLE CHARGE PHASE (TCH)*, after this is a change to the *NO-LOAD PHASE (OCV = OPEN CIRCUIT VOLTAGE)*.
- During the no-load phase the lead-acid battery is *CONTINUALLY MONITORED*. Until recharging occurs, the charge status drops during the no-load phase by a max. 3-5% (charging takes place at the latest after 23 days). The duty factor of the recharging phases is below 1‰, which enables high *ENERGY SAVINGS* and at the same time *REDUCED AGEING*.

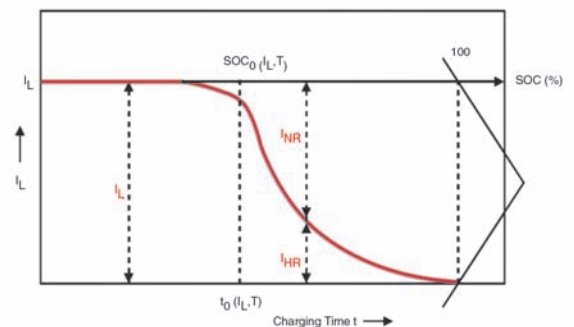

### Technical Note

### INFO

With traditional, standard IU procedures nearly all the energy fed into the battery during the trickle charge phase is expended in side reactions (SR) and hence in the ageing of the battery - with simultaneous deficient charging of the battery (explanation - cf. the following description "serial effect").

# Diagnostic Procedure

## Serial effect:

- the adjacent diagram shows the trend of the individual cell voltages in a 12V AGM UPS battery. To provide reproducible conditions for the sub-sequent charging procedure at the beginning of the recording the battery is *DISCHARGED*.
- After a short pause, charging is commenced with a *CONSTANT CURRENT PHASE* and then subsequently transferring into a *CONSTANT VOLTAGE PHASE*. The charging current is portrayed by the curve in the lower part of the diagram.

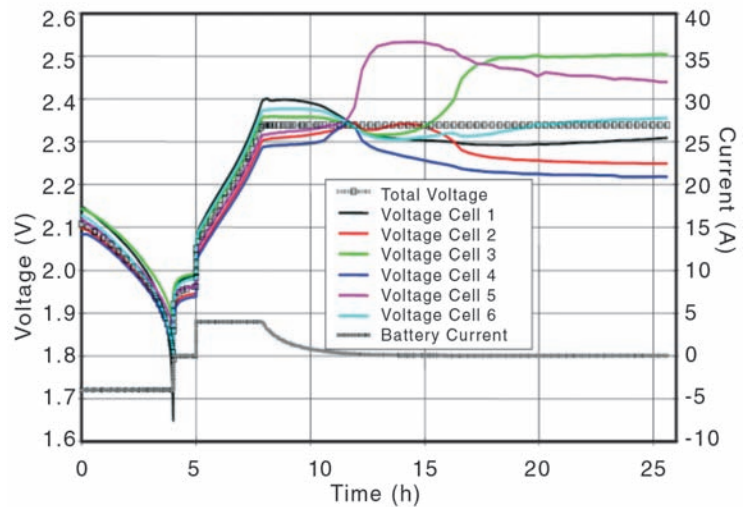

SOURCE: B. Fricke et. al., Lead accumulators for stationary power supplies, "Belecker Fachtage", 2004

### Technical Note

### INFO

During the *CONSTANT CURRENT PHASE* (cf. ACS procedure) the cells behave homogeneously. Internal parameter changes have no effect on the terminal voltage of the other individual cells, because the same current is continually flowing through all cells.

## Serial Effect:

the *NEGATIVE RESULTS OF CONSTANT VOLTAGE CHARGING* become apparent through a considerable divergence of the individual cell voltages as the resulting cell-voltage behaviour shown in the diagram above. During a charging procedure to fully charge a lead-acid battery, the change of any single cell effects all other serially connected cells. During the course of the charging procedure with constant voltage charging, some individual cells develop higher contact voltages, whereas other cells are increasingly less charged and even give-up their charge, so that the contact voltage decreases. The reason for this are inhomogeneities of the cell parameters within the battery (as for example differing internal resistances or *SOC= STATE-OF-CHARGE*).

## Charging Cycles / Capacity Behaviour:

- The adjacent diagram shows the capacity behaviour of a UPS battery (type: gel, 12V/60Ah) over multiple charging and discharging cycles.
- *The D-IPS ACS PROCEDURE HOLDS THE BATTERY CAPACITY STABLE*, whereas after only a few charging/discharging cycles the capacity of UPS battery charged with the conventional IU charging procedure will be noticeably reduced due to deficient charging.

### Technical Note

### INFO

Consequence of *CONSTANT VOLTAGE CHARGING* is an excessive ageing of the battery because single cells are being overloaded during charging procedure while other cells in the battery receive insufficient charge!

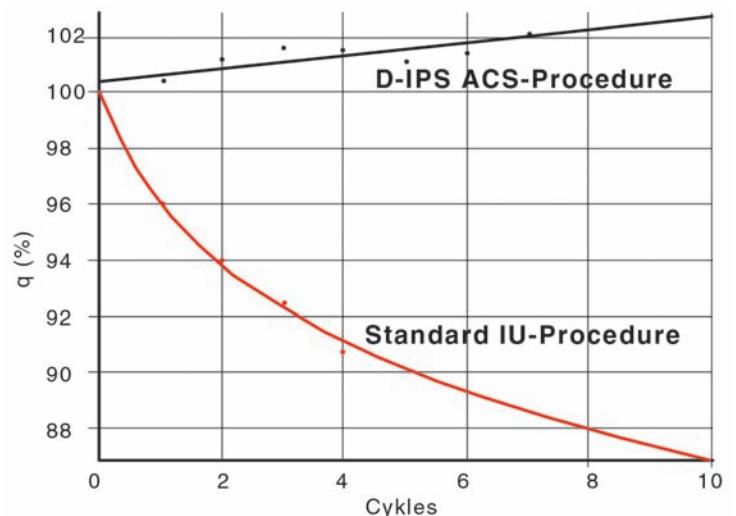

SOURCE: JD. Deutronic

# DC UPS battery management system ECO - 250 W

## Uninterruptible DC system voltage

### DC UPS for lead-acid batteries (standard, AGM, gel, pure lead)

Input: wide range DC 22 V – 30 V, output: DC 10 A, Boost DC 15 A



Battery test/monitoring is cyclic  
 I-U-U charge with car charge level  
 temperature compensated charging voltage  
 deep discharge protection (residual discharge current <300 µA)  
 electronic battery short-circuit protection  
 control by state-of-the-art digital technology  
 signalling via LEDs, relays  
 fault diagnosis (battery temperature, aging, cable break, etc.)  
 Option: fast charge by means of power supply bypass

Description	Part-No.	Type	PU	
<b>Screw terminal</b>				
Output voltage/current	DC 24 V; 10 A	723001	L-COPS-B1-BME-250-24	1
<b>General</b>				
Supported load circuit voltage power supply operation			DC 22 V – DC 30 V	
Supported load circuit voltage battery operation			DC 18 V – DC 27 V	
Deep discharge protection early warning			DC 21.6 V type	
Deep discharge protection deactivation			Threshold DC 18 V type	
Overload protection mains operation			External (current limit by means of DC power supply)	
Overload protection buffer operation			locking electronic deactivation at $I_{out} > I_{nom} \times 1.75$	
Reverse battery protection			Electronic isolation switch	
Battery charge			Temperature is controlled (external sensor included) emergency operation if temperature sensor is not connected	
Battery charging current			max. DC 1.5 A option: fast charging by means of power supply bypass	
Buffer time limit			adjustable by potentiometer from 10 s to 600 s or infinite (deep discharge point)	
External battery			see accessories	
Battery types			all standard types of lead acid batteries	
Signalling	LED green		Mains operation / battery operation	
	LED yellow		Charging	
	LED red		Device or battery fault	
	Relay 1		DC 30 V, DC 1 A, 1 NO contact, mains operation monitoring	
	Relay 2		DC 30 V, DC 1 A, 1 NO contact, warning threshold monitoring	
	Relay 3		DC 30 V, DC 1 A, 1 NO contact, composite error monitoring	
Operation temperature range			-25 °C – 70 °C	
Cooling			Air convection	
Storage temperature range			-40 °C – 85 °C	
Humidity			100 %, condensation allowed (coated circuit boards)	
Own consumption			Buffer mode: 60 mA type	
Battery residual discharge current			<300 µA (deep discharge protection, battery disconnected from load)	
Electrical safety			EN 60950, SELV, protection class III	
Emitted interference			EN 55011 class B	
Interference immunity			EN 61000-6-2	
Protection class			IP 20	
Installation position			Horizontal on all mounting rails acc. EN 60715	
Clearance above			–	
Clearance at the side			–	
Connection cross-sections	Mains supply		Faston flat terminal plugs 6.3 × 0.8 mm	
	Load, battery		Faston flat terminal plugs 6.3 × 0.8 mm	
	Signal		Plug-in screw terminals 10-pin, 0.5 – 2.5 mm <sup>2</sup> , flexible, rigid, RM 3.81	
Dimensions (w × h × d) in mm			39.0 × 139.0 × 130.0	
Weight (kg/piece)			0.500	
Approvals				

# DC UPS battery management system ECO · 250 W

Uninterruptible DC system voltage

DC UPS for lead-acid batteries (standard, AGM, gel, pure lead)

Input: wide range DC 22 V – 30 V, output: DC 10 A, Boost DC 15 A

## Dimensions

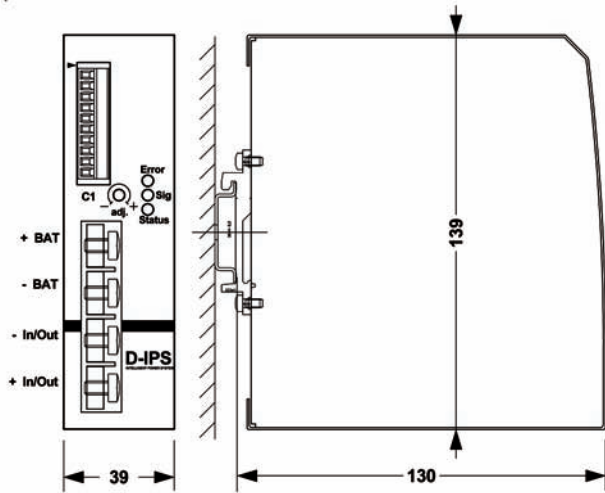

## Signal connection

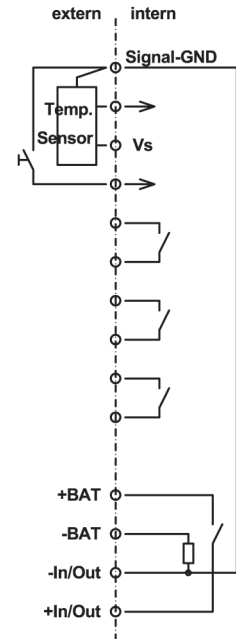
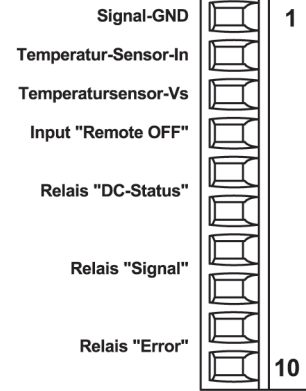

## PIN assignment

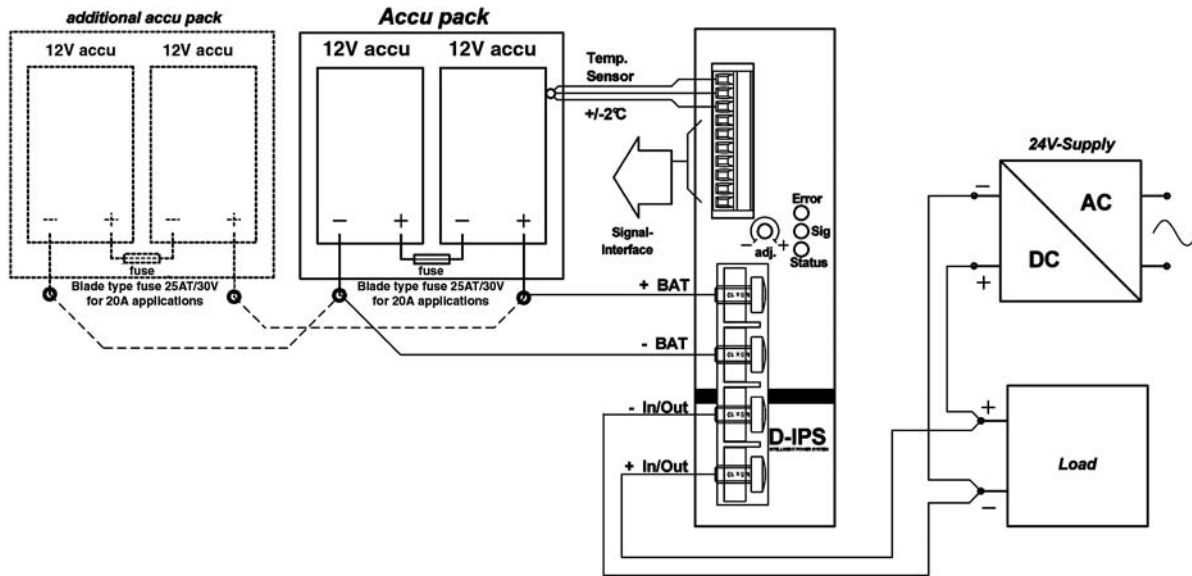

# DC UPS battery management system ECO - 500 W

## Uninterruptible DC system voltage

### DC UPS for lead-acid batteries (standard, AGM, gel, pure lead)

Input: wide range DC 22 V – 30 V, output: DC 20 A, Boost DC 30 A



Battery test/monitoring is cyclic  
 I-U-U charge with car charge level  
 temperature compensated charging voltage  
 deep discharge protection (residual discharge current <300 µA)  
 electronic battery short-circuit protection  
 control by state-of-the-art digital technology  
 signalling via LEDs, relays  
 fault diagnosis (battery temperature, aging, cable break, etc.)  
 Option: fast charge by means of power supply bypass

Description	Part-No.	Type	PU	
<b>Screw terminal</b>				
Output voltage/current	DC 24 V; 20 A	723002	L-COPS-B1-BME-500-24	1
<b>General</b>				
Supported load circuit voltage power supply operation			DC 22 V – DC 30 V	
Supported load circuit voltage battery operation			DC 18 V – DC 27 V	
Deep discharge protection early warning			DC 21.6 V type	
Deep discharge protection deactivation			Threshold DC 18 V type	
Overload protection mains operation			External (current limit by means of DC power supply)	
Overload protection buffer operation			locking electronic deactivation if $I_{out} > I_{nom} \times 1.75$	
Reverse battery protection			Electronic isolation switch	
Battery charge			Temperature is controlled (external sensor included) emergency operation if temperature sensor is not connected	
Battery charging current			max. DC 1.5 A option: fast charging by means of power supply bypass	
Buffer time limit			adjustable by potentiometer from 10 s to 600 s or infinite (deep discharge point)	
External battery			see accessories	
Battery types			all standard types of lead acid batteries	
Signalling	LED green		Mains operation / battery operation	
	LED yellow		Charging	
	LED red		Device or battery fault	
	Relay 1		DC 30 V, DC 1 A, 1 NO contact, mains operation monitoring	
	Relay 2		DC 30 V, DC 1 A, 1 NO contact, warning threshold monitoring	
	Relay 3		DC 30 V, DC 1 A, 1 NO contact, composite error monitoring	
Operation temperature range			-25 °C – 70 °C	
Cooling			Air convection	
Storage temperature range			-40 °C – 85 °C	
Humidity			100 %, condensation allowed (coated circuit boards)	
Own consumption			Buffer mode: 60 mA type	
Battery residual discharge current			<300 µA (deep discharge protection, battery disconnected from load)	
Electrical safety			EN 60950, SELV, protection class III	
Emitted interference			EN 55011 class B	
Interference immunity			EN 61000-6-2	
Protection class			IP 20	
Installation position			Horizontal on all mounting rails acc. EN 60715	
Clearance above			–	
Clearance at the side			–	
Connection cross-sections	Mains supply		Faston flat terminal plugs 6.3 × 0.8 mm	
	Load, battery		Faston flat terminal plugs 6.3 × 0.8 mm	
	Signal		Plug-in screw terminals 10-pin, 0.5 – 2.5 mm <sup>2</sup> , flexible, rigid, RM 3.81	
Dimensions (w × h × d) in mm			39.0 × 139.0 × 130.0	
Weight (kg/piece)			0.500	
Approvals				



# DC UPS battery management system ECO · 500 W

Uninterruptible DC system voltage

DC UPS for lead-acid batteries (standard, AGM, gel, pure lead)

Input: wide range DC 22 V – 30 V, output: DC 20 A, Boost DC 30 A

## Dimensions

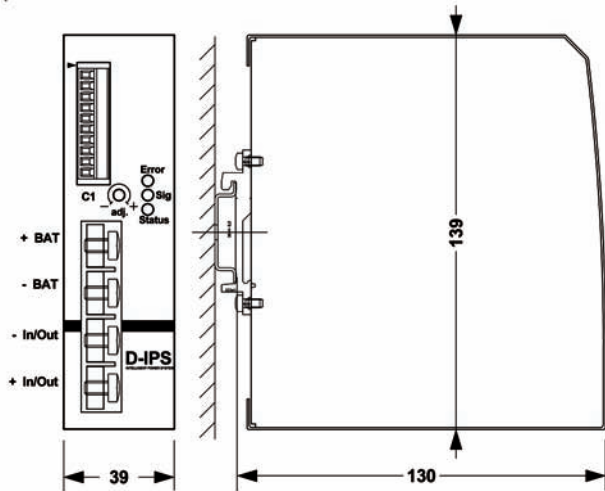

## Signal connection

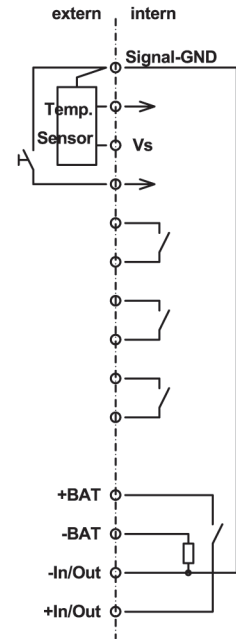
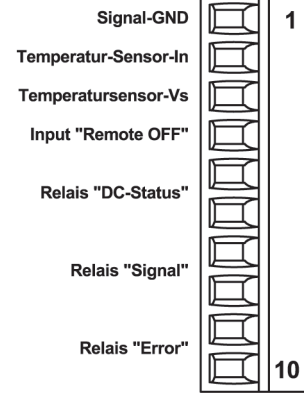

## PIN assignment

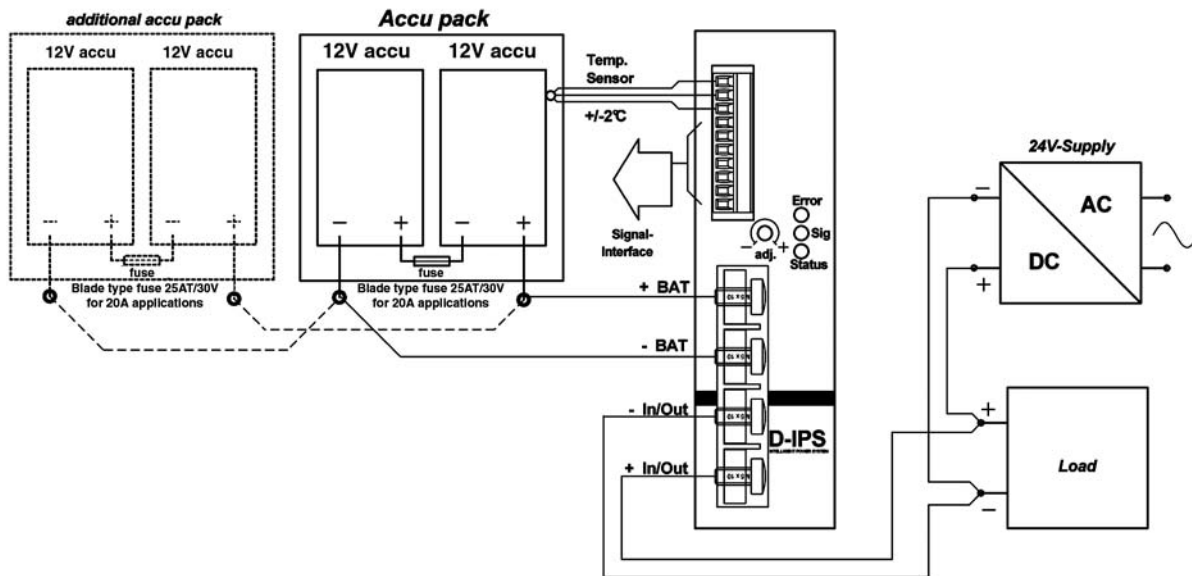

# DC UPS battery management system ECO - 1000 W

## Uninterruptible DC system voltage

### DC UPS for lead-acid batteries (standard, AGM, gel, pure lead)

Input: wide range DC 22 V – 30 V, output: DC 40 A, Boost DC 60 A



Battery test/monitoring is cyclic  
 I-U-U charge with car charge level  
 temperature compensated charging voltage  
 deep discharge protection (residual discharge current <300 µA)  
 electronic battery short-circuit protection  
 control by state-of-the-art digital technology  
 signalling via LEDs, relays  
 fault diagnosis (battery temperature, aging, cable break, etc.)  
 Option: fast charge by means of power supply bypass

Description	Part-No.	Type	PU	
<b>Screw terminal</b>				
Output voltage/current	DC 24 V; 40 A	723004	L-COPS-B1-BME-1000-24	1
<b>General</b>				
Supported load circuit voltage power supply operation			DC 22 V – DC 30 V	
Supported load circuit voltage battery operation			DC 18 V – DC 27 V	
Deep discharge protection early warning			DC 21.6 V type	
Deep discharge protection deactivation			Threshold DC 18 V type	
Overload protection mains operation			External (current limit by means of DC power supply)	
Overload protection buffer operation			locking electronic deactivation if $I_{out} > I_{nom} \times 1.75$	
Reverse battery protection			Electronic isolation switch	
Battery charge			Temperature is controlled (external sensor included) emergency operation if temperature sensor is not connected	
Battery charging current			max. DC 1.5 A option: fast charging by means of power supply bypass	
Buffer time limit			adjustable by potentiometer from 10 s to 600 s or infinite (deep discharge point)	
External battery			see accessories	
Battery types			all standard types of lead acid batteries	
Signalling	LED green		Mains operation / battery operation	
	LED yellow		Charging	
	LED red		Device or battery fault	
	Relay 1		DC 30 V, DC 1 A, 1 NO contact, mains operation monitoring	
	Relay 2		DC 30 V, DC 1 A, 1 NO contact, warning threshold monitoring	
	Relay 3		DC 30 V, DC 1 A, 1 NO contact, composite error monitoring	
Operation temperature range			-25 °C – 70 °C	
Cooling			Air convection	
Storage temperature range			-40 °C – 85 °C	
Humidity			100 %, condensation allowed (coated circuit boards)	
Own consumption			Buffer mode: 60 mA type	
Battery residual discharge current			<300 µA (deep discharge protection, battery disconnected from load)	
Electrical safety			EN 60950, SELV, protection class III	
Emitted interference			EN 55011 class B	
Interference immunity			EN 61000-6-2	
Protection class			IP 20	
Installation position			Horizontal on all mounting rails acc. EN 60715	
Clearance above			–	
Clearance at the side			–	
Connection cross-sections	Mains supply		Faston flat terminal plugs 6.3 × 0.8 mm	
	Load, battery		Faston flat terminal plugs 6.3 × 0.8 mm	
	Signal		Plug-in screw terminals 10-pin, 0.5 – 2.5 mm <sup>2</sup> , flexible, rigid, RM 3.81	
Dimensions (w × h × d) in mm			39.0 × 139.0 × 130.0	
Weight (kg/piece)			0.500	
<b>Approvals</b>				

# DC UPS battery management system ECO · 1000 W

Uninterruptible DC system voltage

DC UPS for lead-acid batteries (standard, AGM, gel, pure lead)

Input: wide range DC 22 V – 30 V, output: DC 40 A, Boost DC 60 A

## Dimensions

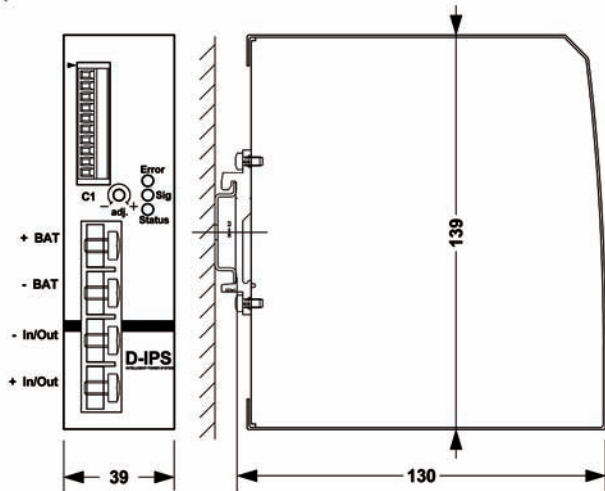

## Signal connection

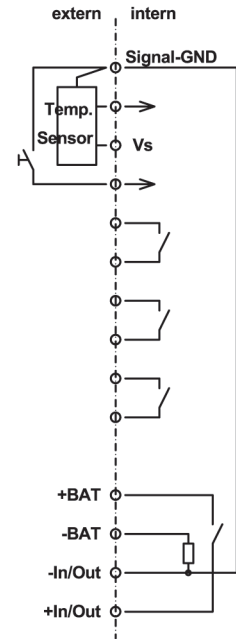
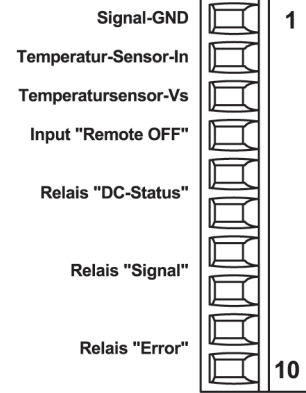

## PIN assignment

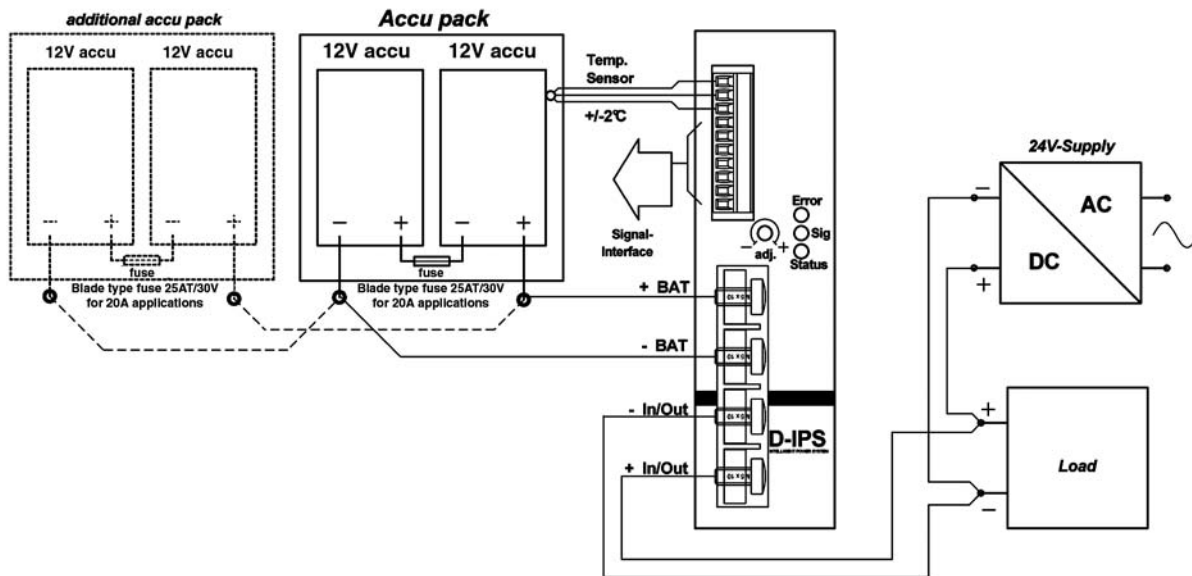

# DC UPS battery management system PRO - 250 W

**Primary switchmode power supply, PFC, Single-phase**  
**DC UPS for all battery types (standard, AGM, gel, pure lead)**  
**Input: wide range AC 85 V – 276 V, output: DC 24 V – adjustable**



Active PFC wide range  
 Extensive protective measures such as short circuit/no-load proof, overvoltage and overtemperature  
 Very low standby power and equally high effectiveness over the entire entrance area  
 no inrush current  
 Patent protected, highly efficient ACS battery charging and diagnostic method (ACS: Adaptive Current Step)  
 Thermal battery management incl. cyclic monitoring – prevents thermal runaway  
 Maximum battery charging current adjustable  
 Deep discharge protection (residual discharge current < 300 µA)  
 electronic battery short-circuit protection  
 Suitable for VDS applications  
 Absence of feedback on energy sources  
 Fault diagnosis (battery temperature, ageing, cable break, etc.)  
 Signalling via LEDs, relays

Description	Part-No.	Type	PU	
<b>Screw terminal</b>				
Output voltage/current	DC 24 V; 10 A	723011	L-COPS-B1-BM-250-24	1
<b>Input</b>				
Nominal voltage	AC 120 V / 230 V			
Operation voltage range	AC 85 V – 276 V, short-time < 1 sec. AC 60 V – 300 V, DC 130 V – 350 V, (TN-S, TN-C, TT, IT networks)			
Line frequency	47 – 65 Hz			
Rated current	U <sub>1</sub> = AC 230 V: 4 A / U <sub>1</sub> = AC 120 V: 9 A			
Inrush current	no inrush current (active limit: start-up by means of ramp)			
Internal fuse	T10 A / AC 250 V			
External fuse	additional fuse not necessary			
Power Factor Correction P.F.C.	> 0.98 (active)			
Over voltage protection	Varistor 4.5 kA, 71 J			
<b>Output</b>				
Rated voltage output	DC 24 V			
Rated current output	DC 10 A			
Max. output current	–			
Peak output current	–			
Voltage trim range	22.5 V – 28.8 V			
Load control (static)	10 % – 90 %: < 0.05 % (type 0.05 %)			
Load control (dynamic)	10 % – 90 %: < 5 %			
Response time	< 1 ms			
Change of input	< 0.2 % (type 0.02 %)			
Temperature drift /K	-25 °C – 70 °C: < 1 %, (type 0.5 %), 0 °C – 60 °C: 0.4 %			
Rise time	10 % – 90 %: < 50 ms			
Ripple	< 50 mV pp			
Switching peaks (20 MHz)	< 100 mV pp			
Hold up time	UPS			
<b>Current limit behaviour</b>				
Rated over load protection	In the case of an overload, the buffer battery is switched to the power supply (I=const.)			
Short-circuit protection	Locking electronic deactivation of the battery path (if I <sub>out</sub> > I <sub>nom</sub> × 2.05)			
<b>Supported load circuit voltage (battery operation)</b>				
Output voltage	Battery voltage (Attention – note configurable switch-off threshold)			
Deep discharge protection	Signal thresholds or threshold values are individually adjustable via interface Early warning: type DC 21.0 V, switch-off threshold type DC 19.2 V buffer time threshold: 10 s to infinity			
Reverse battery protection	Electronic isolation switch			
Battery charge	Temperature is controlled by means of an external sensor, emergency operation if sensor is not connected			
Battery charging current	see table			
Note	<p><b>Important note:</b>                      Apart from the output power for supplying the load, the power supply unit integrated in the battery management must also be provided for the charging power, which is needed by the battery.                      The L-COPS battery management system has been designed to be able to provide the nominal output power for supplying the load and as well as the nominal charging current for supplying the battery under normal operating conditions (s. table 1).                      If a higher charging current is configured than the nominal value, care must be taken to ensure that the power requirement of the load is reduced accordingly (in case of doubt, an L-COPS variant with a greater power supply unit should be chosen).</p>			
Calculation of the charging capacity	$P_{\text{change}} = U_{\text{out}} \cdot I_{\text{change}}$ $P_{\text{change}} = 30 \text{ V} \cdot 2 \text{ A} = 60 \text{ W}$ $P_{\text{change}} = 30 \text{ V} \cdot 4 \text{ A} = 120 \text{ W}$			
<b>EMC (electromagnetic compatibility)</b>				
HF Emission	EN 55011, class B			
Primary side current harmonics	EN 61000-3-2			
Discharge of static capacity	EN 61000-4-2, 4/8 kV, criterion B			
Electromagnetic HF field	EN 61000-4-3, 10 V/m, criterion A			
Burst	EN 61000-4-4, 2 kV/1 kV, criterion B			
Surge	EN 61000-4-5, 1 kV sym/2 kV unsym., criterion B			

# DC UPS battery management system PRO · 250 W

**Primary switchmode power supply, PFC, Single-phase**  
**DC UPS for all battery types (standard, AGM, gel, pure lead)**  
**Input: wide range AC 85 V – 276 V, output: DC 24 V – adjustable**

Conducted HF influence	EN 61000-4-6, 10 V	
Voltage interruptions	EN 61000-4-11, mains buffering > 20 ms	
<b>General</b>		
Operation temperature range	-25 °C – 50 °C, 70 °C: from 50 °C: derating 1.5 %/°C	
Cooling	Air convection	
Storage temperature range	-40 °C – 85 °C	
Humidity	100 %, condensation allowed (coated circuit boards)	
Vibration acc. IEC 68-2-6	10 Hz – 150 Hz, 0.15 mm or 2g, 90 min in resonance	
Shock acc. IEC 68-2-27	30g for 18 ms in three spatial directions	
Pollution degree	2 acc. EN 50178	
Climate class	3K3 acc. EN 60721	
Installation position	Horizontal on all mounting rails acc. EN 60715	
Clearance above	> 80 mm	
Clearance at the side	> 3 mm	
Connection cross-sections	Mains supply	Plug-in screw terminals, 0.2 – 2.5 mm <sup>2</sup> , flexible, rigid
	Load, battery	Plug-in screw terminals, 0.25 – 4 mm <sup>2</sup> , flexible, rigid
	Signal	Plug-in screw terminals, 0.5 – 2.5 mm <sup>2</sup> , flexible, rigid
Dimensions (w × h × d) in mm	98.0 × 139.0 × 130.0	
Weight (kg/piece)	1.600	
Electrical safety	UL 508, EN 60950, UL 60950, EN 50178	
Insulation voltage	Input/output: 3 kV, individually checked output/housing: 500 V	
Protection class	IP 20	
IP rating	Class 1, with PE connection	
M.T.B.F.	>1000000 h, IEC 1709 (SN 29500)	
Efficiency	approx. 91 %	
No-load power	type 3.5 W	
Own consumption	type 1.5 W	
Battery residual discharge current	type 300 µA (deep discharge protection, battery disconnected from load)	
Signalling	Mains supply	green: 90 % – 110 % from the set value, red: overload
	Battery MM	4 LEDs (green, 2 x yellow, red)
Signal outputs	3 potential free relays with one changeover each (DC 30 V, 1 A)	
Remote Start/OFF	Battery support of the load can be activated/deactivated by means of control cable in the absence of mains supply	
Temperature sensor	Connection of an analogue, active temperature sensor	

## Dimensions

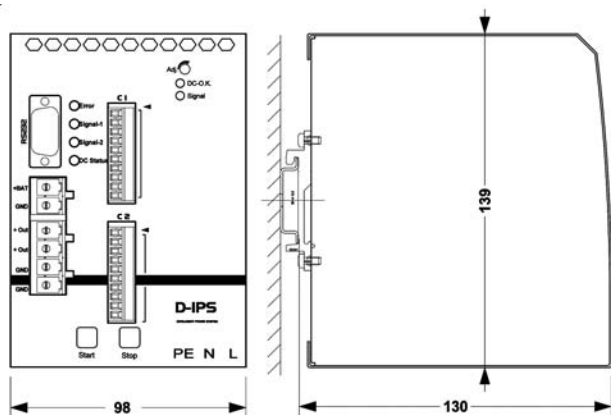

## Signal connection

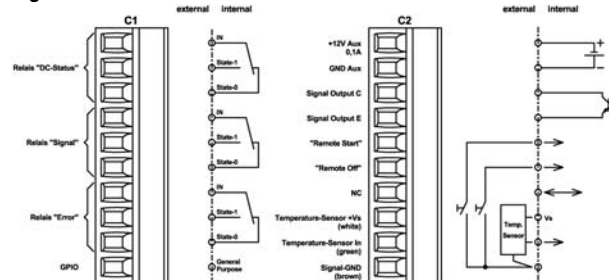

# DC UPS battery management system PRO - 500 W

**Primary switchmode power supply, PFC, Single-phase**  
**DC UPS for all battery types (standard, AGM, gel, pure lead)**  
**Input: wide range AC 85 V – 276 V, output: DC 24 V – adjustable**



Active PFC wide range  
 Extensive protective measures such as short circuit/no-load proof, overvoltage and overtemperature  
 Very low standby power and equally high effectiveness over the entire entrance area  
 no inrush current  
 Patent protected, highly efficient ACS battery charging and diagnostic method (ACS: Adaptive Current Step)  
 Thermal battery management incl. cyclic monitoring – prevents thermal runaway  
 Maximum battery charging current adjustable  
 Deep discharge protection (residual discharge current < 300 µA)  
 electronic battery short-circuit protection  
 Suitable for VDS applications  
 Absence of feedback on energy sources  
 Fault diagnosis (battery temperature, ageing, cable break, etc.)  
 Signalling via LEDs, relays

Description	Part-No.	Type	PU	
<b>Screw terminal</b>				
Output voltage/current	DC 24 V; 20 A	723012	L-COPS-B1-BM-500-24	1
<b>Input</b>				
Nominal voltage	AC 120 V / 230 V			
Operation voltage range	AC 85 V – 276 V, short-time < 1 sec. AC 60 V – 300 V, DC 130 V – 350 V, (TN-S, TN-C, TT, IT networks)			
Line frequency	47 – 65 Hz			
Rated current	U <sub>1</sub> = AC 230 V: 4 A / U <sub>1</sub> = AC 120 V: 9 A			
Inrush current	no inrush current (active limit: start-up by means of ramp)			
Internal fuse	T10 A / AC 250 V			
External fuse	additional fuse not necessary			
Power Factor Correction P.F.C.	> 0.98 (active)			
Over voltage protection	Varistor 4.5 kA, 71 J			
<b>Output</b>				
Rated voltage output	DC 24 V			
Rated current output	DC 20 A			
Max. output current	–			
Peak output current	–			
Voltage trim range	22.5 V – 28.8 V			
Load control (static)	10 % – 90 %: < 0.05 % (type 0.05 %)			
Load control (dynamic)	10 % – 90 %: < 5 %			
Response time	< 1 ms			
Change of input	< 0.2 % (type 0.02 %)			
Temperature drift /K	-25 °C – 70 °C: < 1 %, (type 0.5 %), 0 °C – 60 °C: 0.4 %			
Rise time	10 % – 90 %: < 50 ms			
Ripple	< 50 mV pp			
Switching peaks (20 MHz)	< 100 mV pp			
Hold up time	UPS			
<b>Current limit behaviour</b>				
Rated over load protection	In the case of an overload, the buffer battery is switched to the power supply (I=const.)			
Short-circuit protection	Locking electronic deactivation of the battery path (if I <sub>out</sub> > I <sub>nom</sub> × 2.05)			
<b>Supported load circuit voltage (battery operation)</b>				
Output voltage	Battery voltage (Attention – note configurable switch-off threshold)			
Deep discharge protection	Signal thresholds or threshold values are individually adjustable via interface Early warning: type DC 21.0 V, switch-off threshold type DC 19.2 V buffer time threshold: 10 s to infinity			
Reverse battery protection	Electronic isolation switch			
Battery charge	Temperature is controlled by means of an external sensor, emergency operation if sensor is not connected			
Battery charging current	see table			
Note	<p><b>Important note:</b>                      Apart from the output power for supplying the load, the power supply unit integrated in the battery management must also be provided for the charging power, which is needed by the battery.                      The L-COPS battery management system has been designed to be able to provide the nominal output power for supplying the load and as well as the nominal charging current for supplying the battery under normal operating conditions (s. table 1).                      If a higher charging current is configured than the nominal value, care must be taken to ensure that the power requirement of the load is reduced accordingly (in case of doubt, an L-COPS variant with a greater power supply unit should be chosen).</p>			
Calculation of the charging capacity	$P_{\text{change}} = U_{\text{out}} \cdot I_{\text{change}}$ $P_{\text{change}} = 30 \text{ V} \cdot 2 \text{ A} = 60 \text{ W}$ $P_{\text{change}} = 30 \text{ V} \cdot 4 \text{ A} = 120 \text{ W}$			
<b>EMC (electromagnetic compatibility)</b>				
HF Emission	EN 55011, class B			
Primary side current harmonics	EN 61000-3-2			
Discharge of static capacity	EN 61000-4-2, 4/8 kV, criterion B			
Electromagnetic HF field	EN 61000-4-3, 10 V/m, criterion A			
Burst	EN 61000-4-4, 2 kV/1 kV, criterion B			
Surge	EN 61000-4-5, 1 kV sym/2 kV unsym., criterion B			

# DC UPS battery management system PRO · 500 W

**Primary switchmode power supply, PFC, Single-phase**  
**DC UPS for all battery types (standard, AGM, gel, pure lead)**  
**Input: wide range AC 85 V – 276 V, output: DC 24 V – adjustable**

Conducted HF influence	EN 61000-4-6, 10 V	
Voltage interruptions	EN 61000-4-11, mains buffering > 20 ms	
<b>General</b>		
Operation temperature range	-25 °C – 50 °C, 70 °C: from 50 °C: derating 1.5 %/°C	
Cooling	Air convection	
Storage temperature range	-40 °C – 85 °C	
Humidity	100 %, condensation allowed (coated circuit boards)	
Vibration acc. IEC 68-2-6	10 Hz – 150 Hz, 0.15 mm or 2g, 90 min in resonance	
Shock acc. IEC 68-2-27	30g for 18 ms in three spatial directions	
Pollution degree	2 acc. EN 50178	
Climate class	3K3 acc. EN 60721	
Installation position	Horizontal on all mounting rails acc. EN 60715	
Clearance above	> 80 mm	
Clearance at the side	> 3 mm	
Connection cross-sections	Mains supply	Plug-in screw terminals, 0.2 – 2.5 mm <sup>2</sup> , flexible, rigid
	Load, battery	Plug-in screw terminals, 0.25 – 4 mm <sup>2</sup> , flexible, rigid
	Signal	Plug-in screw terminals, 0.5 – 2.5 mm <sup>2</sup> , flexible, rigid
Dimensions (w × h × d) in mm	98.0 × 139.0 × 130.0	
Weight (kg/piece)	1.900	
Electrical safety	UL 508, EN 60950, UL 60950, EN 50178	
Insulation voltage	Input/output: 3 kV, individually checked output/housing: 500 V	
Protection class	IP 20	
IP rating	Class 1, with PE connection	
M.T.B.F.	>1000000 h, IEC 1709 (SN 29500)	
Efficiency	approx. 91 %	
No-load power	type 3.5 W	
Own consumption	type 1.5 W	
Battery residual discharge current	type 300 µA (deep discharge protection, battery disconnected from load)	
Signalling	Mains supply	green: 90 % – 110 % from the set value, red: overload
	Battery MM	4 LEDs (green, 2 x yellow, red)
Signal outputs	3 potential free relays with one changeover each (DC 30 V, 1 A)	
Remote Start/OFF	Battery support of the load can be activated/deactivated by means of control cable in the absence of mains supply	
Temperature sensor	Connection of an analogue, active temperature sensor	

## Dimensions

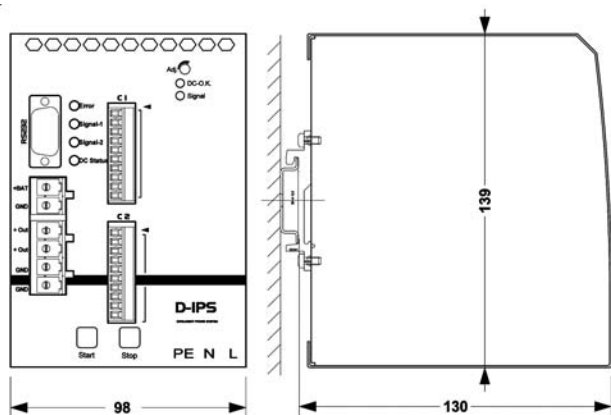

## Signal connection

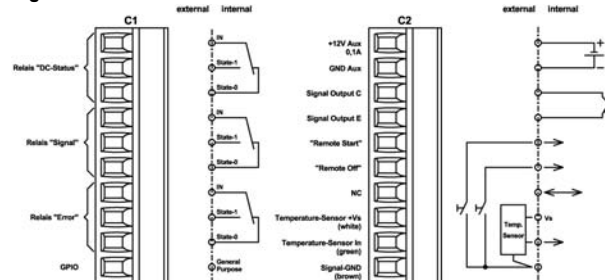

# DC UPS battery management system PRO - 1000 W

**Primary switchmode power supply, PFC, Single-phase**  
**DC UPS for all battery types (standard, AGM, gel, pure lead)**  
**Input: wide range AC 85 V – 276 V, output: DC 24 V – adjustable**



Active PFC wide range  
 Extensive protective measures such as short circuit/no-load proof, overvoltage and overtemperature  
 Very low standby power and equally high effectiveness over the entire entrance area  
 no inrush current  
 Patent protected, highly efficient ACS battery charging and diagnostic method (ACS: Adaptive Current Step)  
 Thermal battery management incl. cyclic monitoring – prevents thermal runaway  
 Maximum battery charging current adjustable  
 Deep discharge protection (residual discharge current < 300 µA)  
 electronic battery short-circuit protection  
 Suitable for VDS applications  
 Absence of feedback on energy sources  
 Fault diagnosis (battery temperature, ageing, cable break, etc.)  
 Signalling via LEDs, relays

Description	Part-No.	Type	PU	
<b>Screw terminal</b>				
Output voltage/current	DC 24 V; 40 A	723014	L-COPS-B1-BM-1000-24	1
<b>Input</b>				
Nominal voltage	AC 120 V / 230 V			
Operation voltage range	AC 85 V – 276 V, short-time < 1 sec. AC 60 V – 300 V, DC 130 V – 350 V, (TN-S, TN-C, TT, IT networks)			
Line frequency	47 – 65 Hz			
Rated current	U <sub>i</sub> = AC 230 V: 9 A / U <sub>i</sub> = AC 120 V: 13 A			
Inrush current	no inrush current (active limit: start-up by means of ramp)			
Internal fuse	T16 A / AC 250 V			
External fuse	additional fuse not necessary			
Power Factor Correction P.F.C.	> 0.98 (active)			
Over voltage protection	Varistor 8 kA, 151 J			
<b>Output</b>				
Rated voltage output	DC 24 V			
Rated current output	DC 40 A			
Max. output current	–			
Peak output current	–			
Voltage trim range	22.5 V – 28.8 V			
Load control (static)	10 % – 90 %: < 0.05 % (type 0.05 %)			
Load control (dynamic)	10 % – 90 %: < 5 %			
Response time	< 1 ms			
Change of input	< 0.2 % (type 0.02 %)			
Temperature drift /K	-25 °C – 70 °C: < 1 %, (type 0.5 %), 0 °C – 60 °C: 0.4 %			
Rise time	10 % – 90 %: < 50 ms			
Ripple	< 50 mV pp			
Switching peaks (20 MHz)	< 100 mV pp			
Hold up time	UPS			
<b>Current limit behaviour</b>				
Rated over load protection	In the case of an overload, the buffer battery is switched to the power supply (I=const.)			
Short-circuit protection	Locking electronic deactivation of the battery path (if I <sub>out</sub> > I <sub>nom</sub> × 2.05)			
<b>Supported load circuit voltage (battery operation)</b>				
Output voltage	Battery voltage (Attention – note configurable switch-off threshold)			
Deep discharge protection	Signal thresholds or threshold values are individually adjustable via interface Early warning: type DC 21.0 V, switch-off threshold type DC 19.2 V buffer time threshold: 10 s to infinity			
Reverse battery protection	Electronic isolation switch			
Battery charge	Temperature is controlled by means of an external sensor, emergency operation if sensor is not connected			
Battery charging current	see table			
Note	<p><b>Important note:</b>                  Apart from the output power for supplying the load, the power supply unit integrated in the battery management must also be provided for the charging power, which is needed by the battery.                  The L-COPS battery management system has been designed to be able to provide the nominal output power for supplying the load and as well as the nominal charging current for supplying the battery under normal operating conditions (s. table 1).                  If a higher charging current is configured than the nominal value, care must be taken to ensure that the power requirement of the load is reduced accordingly (in case of doubt, an L-COPS variant with a greater power supply unit should be chosen).</p>			
Calculation of the charging capacity	$P_{\text{change}} = U_{\text{out}} \cdot I_{\text{change}}$ $P_{\text{change}} = 30 \text{ V} \cdot 2 \text{ A} = 60 \text{ W}$ $P_{\text{change}} = 30 \text{ V} \cdot 4 \text{ A} = 120 \text{ W}$			
<b>EMC (electromagnetic compatibility)</b>				
HF Emission	EN 55011, class B			
Primary side current harmonics	EN 61000-3-2			
Discharge of static capacity	EN 61000-4-2, 4/8 kV, criterion B			
Electromagnetic HF field	EN 61000-4-3, 10 V/m, criterion A			
Burst	EN 61000-4-4, 2 kV/1 kV, criterion B			
Surge	EN 61000-4-5, 1 kV sym/2 kV unsym., criterion B			



# DC UPS battery management system PRO · 1000 W

**Primary switchmode power supply, PFC, Single-phase**  
**DC UPS for all battery types (standard, AGM, gel, pure lead)**  
**Input: wide range AC 85 V – 276 V, output: DC 24 V – adjustable**

Conducted HF influence	EN 61000-4-6, 10 V	
Voltage interruptions	EN 61000-4-11, mains buffering > 20 ms	
<b>General</b>		
Operation temperature range	-25 °C – 50 °C, 70 °C: from 50 °C: derating 1.5 %/°C	
Cooling	Air convection	
Storage temperature range	-40 °C – 85 °C	
Humidity	100 %, condensation allowed (coated circuit boards)	
Vibration acc. IEC 68-2-6	10 Hz – 150 Hz, 0.15 mm or 2g, 90 min in resonance	
Shock acc. IEC 68-2-27	30g for 18 ms in three spatial directions	
Pollution degree	2 acc. EN 50178	
Climate class	3K3 acc. EN 60721	
Installation position	Horizontal on all mounting rails acc. EN 60715	
Clearance above	> 80 mm	
Clearance at the side	> 3 mm	
Connection cross-sections	Mains supply	Plug-in screw terminals, 0.2 – 2.5 mm <sup>2</sup> , flexible, rigid
	Load, battery	Plug-in screw terminals, 0.25 – 4 mm <sup>2</sup> , flexible, rigid
	Signal	Plug-in screw terminals, 0.5 – 2.5 mm <sup>2</sup> , flexible, rigid
Dimensions (w × h × d) in mm	119.0 × 139.0 × 130.0	
Weight (kg/piece)	4.200	
Electrical safety	UL 508, EN 60950, UL 60950, EN 50178	
Insulation voltage	Input/output: 3 kV, individually checked output/housing: 500 V	
Protection class	IP 20	
IP rating	Class 1, with PE connection	
M.T.B.F.	>1000000 h, IEC 1709 (SN 29500)	
Efficiency	approx. 91 %	
No-load power	type 3.5 W	
Own consumption	type 1.5 W	
Battery residual discharge current	type 300 µA (deep discharge protection, battery disconnected from load)	
Signalling	Mains supply	green: 90 % – 110 % from the set value, red: overload
	Battery MM	4 LEDs (green, 2 x yellow, red)
Signal outputs	3 potential free relays with one changeover each (DC 30 V, 1 A)	
Remote Start/OFF	Battery support of the load can be activated/deactivated by means of control cable in the absence of mains supply	
Temperature sensor	Connection of an analogue, active temperature sensor	

## Dimensions

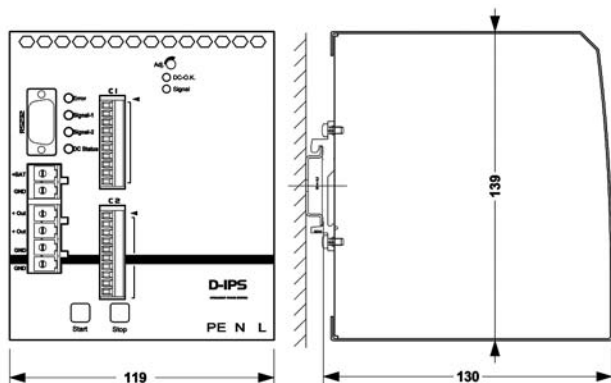

## Signal connection

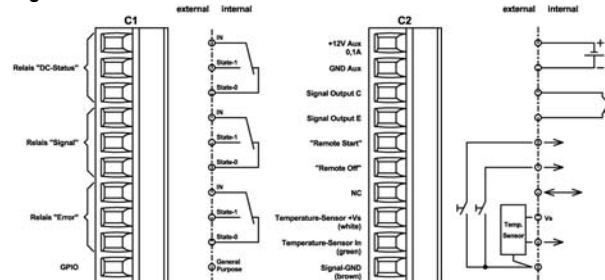

# Accu-Modules for DC UPS and accessories

## VRLA lead Accumulators inclusive temperature sensor 7 Ah, 14 Ah



Description	Part-No.	Type	PU	
<b>VRLA Accu incl T-Sensor</b>				
Nominal voltage	DC 24 V / 7 Ah	723020	L-BPT24-7AH	1
	DC 24 V / 14 Ah	723022	L-BPT24-14AH	1
<b>General</b>				
	<b>L-BPT24-7AH</b>	<b>L-BPT24-14AH</b>		
Output fuse	1×25 A	2×25 A		
Parallel-/series connection		yes		
Weight (kg/piece)	7	14		
Dimensions (w × h × d)	185.4 × 124.5 × 170.0 mm	306.4 × 124.5 × 185.0 mm		
Ambient-temperature range min./max.	operation: 0 °C – 40 °C			
Life time (Eurobat)	3 - 5 years			
Latest installation	9 months @ 20 °C – 30 °C			
<b>Accessories</b>				
	<b>Article number</b>	<b>Type</b>	<b>PU</b>	
Temperature sensor	723024	L-COPS-TS	1	

# Notes

---

## Germany

Friedrich Lütze GmbH & Co. KG  
PO Box 1224 (PLZ 71366)  
Bruckwiesenstrasse 17-19  
D-71384 Weinstadt  
Tel.: +49 (0)71 51 60 53-0  
Fax: +49 (0)71 51 60 53-277(-288)  
info@luetze.de



### Cables and Cords

### Cable Assembly

### C-Tracks

### Cable fittings

### Cable conduits

### LSC-Wiring-System

### Module- and Interface Technology

### Ethernet Connectivity

### Suppression Technology

### Power Supplies

### Railway-Technology

## United Kingdom

LÜTZE Ltd.  
Unit 3 Sandy Hill Park  
Sandy Way, Amington  
Tamworth, Staffs, B77 4DU  
Tel.: +44 (0)18 27 31333-0  
Fax: +44 (0)18 27 31333-2  
sales.gb@luetze.co.uk

## USA

LUTZE INC.  
13330 South Ridge Drive  
Charlotte, NC 28273  
Tel.: +1 (704) 504-0222  
Fax: +1 (704) 504 -0223  
info@lutze.com

## Austria

LÜTZE Elektrotechnische  
Erzeugnisse Ges.m.b.H.  
office@luetze.at

## Switzerland

LÜTZE AG  
info@luetze.ch

## France

LUTZE SAS  
lutze@lutze.fr

## Spain

LUTZE, S.L.  
info@lutze.es

## China

Luetze Trading (Shanghai) Co.Ltd.  
info@luetze.cn

[www.luetze.com](http://www.luetze.com)

**LUTZE**   
Systematic Technology