



# RPS-300

## Features

- Various Sensing Ranges
- RPS-500 Compatible
- Narrow Sensing Beam
- 3-Way Power Operation
- High Frequency
- Isolated Form C Relay Output
- LED Indicator
- Small Electronic Controller
- Sealed Transducer
- Small Remote Transducer

The RPS-300 is a high frequency, sealed transducer unit best suited for environments where dirt and moisture are a problem. The transducer head is constructed of galvanized steel with a silicon rubber sensing face. The remote transducer allows for mounting of the sensor head in cramped spaces while the controller is out of the way. The ranging and proximity modes provide the versatility of simple detection, or actual distance measuring. The isolated form C relay furnishes N.O. and N.C. outputs, and with the addition of the RPS-500 card various



analog outputs are supplied. The RPS-300 sensor operates at a frequency of 222kHz for the 14" and 36" ranges and 150kHz for the 72" range. This sensor has a narrow sensing beam. Sensing ranges available for the RPS-300 include 4" to 14", 5" to 36", and 8" to 72". Mounting flanges, LED indicator, ranging potentiometer and 6-ft. transducer cable are included. Optional cable lengths are available.

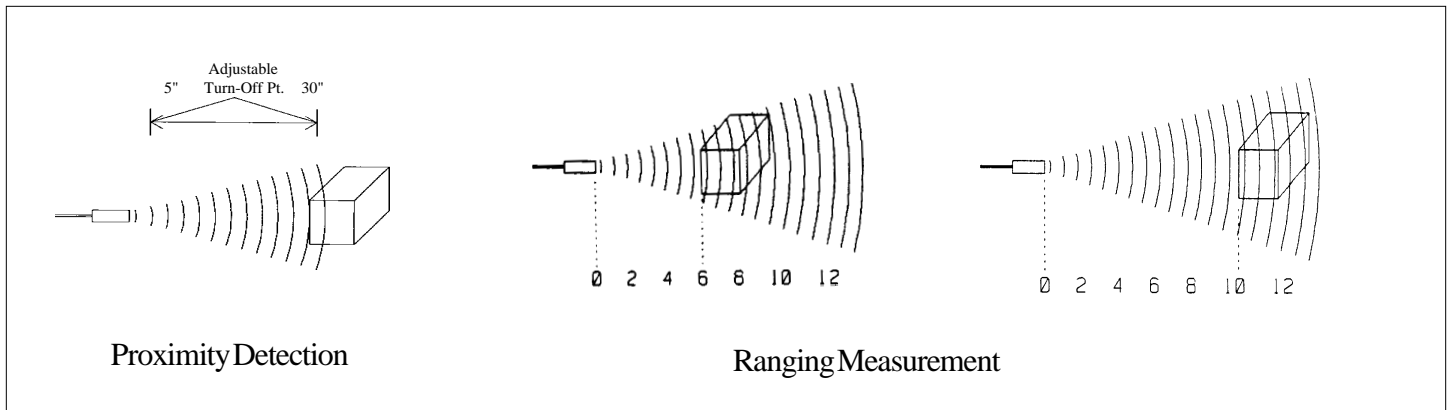

### Proximity Detection

Proximity detection is the detection of an object in a given range. The detection range of the RPS-300 is controlled by the "Range Control" potentiometer located on the front cover of the controller. Any object within the desired range is detected, while objects out of range are ignored. The detect point is independent of size, material, and reflectivity. The Proximity Option is denoted by the part number RPS-300-14.

### Ranging Measurement

With the addition of the RPS-500 card, Analog outputs of 0-10 VDC and 4-20 mA are provided. Precise distances of an object moving to and from the transducer are measured via time intervals between transmitted and reflected bursts of ultrasonic sound. The example shows a target detected at 6 inches from the transducer and moving to 10 inches. The distance change is continuously calculated and outputted. Ranging Option is indicated by following the part number with (-500). (Example: RPS-300-14-500)

# Specifications:

Operational Range:	Adjustable 4" to 14" Adjustable 5" to 36" Adjustable 8" to 72"
Power Input:	120VAC * Only 120VAC or 24VDC with 500 Analog card. 15-24VDC 12VDC Regulated 12-17VAC
Input Current:	30 Milliamps
Input with 500 card:	50 Milliamps
Ambient Temperature:	0°C to 60°C or 32°F to 140°F
Controller :	Metal Enclosed
Transducer Housing:	Galvanized Steel in 14" & 36", Plastic in 72"
Transducer:	Silicone Rubber or Teflon Sensing Face
Output: N.O., N.C.	Isolated Form C Relay .5 Amp Maximum at 120VAC 12VDC Logic Signal
Output with 500 card:	0 - 10VDC, 4 - 20 mA Analog Outputs with Zero, Span, Sample, and Hold controls.
Transducer Frequency:	222kHz for 14" and 36", 150kHz for 72"
Response Time:	4" to 14"      5" to 36"      8" to 72" 30mS - On    50mS - On    60mS - On 30mS - Off   50mS - Off   60mS - Off
Weight of Controller:	34.2 ounces
Weight of Transducer:	4.5 ounces

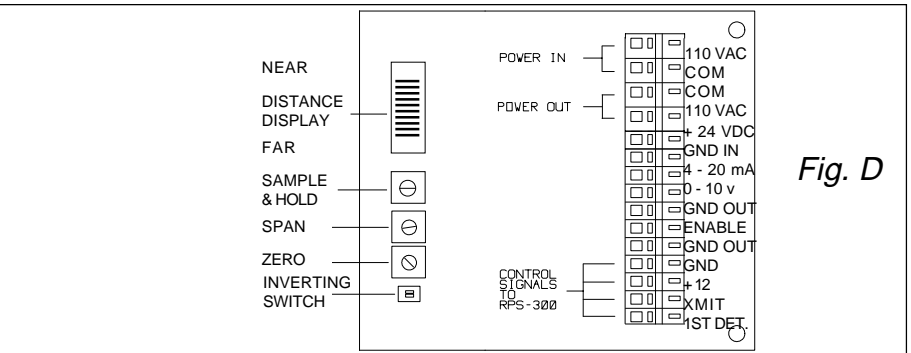
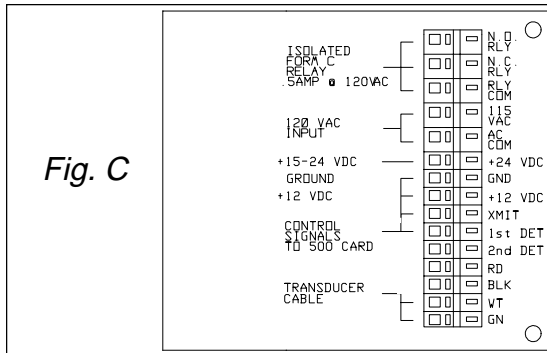
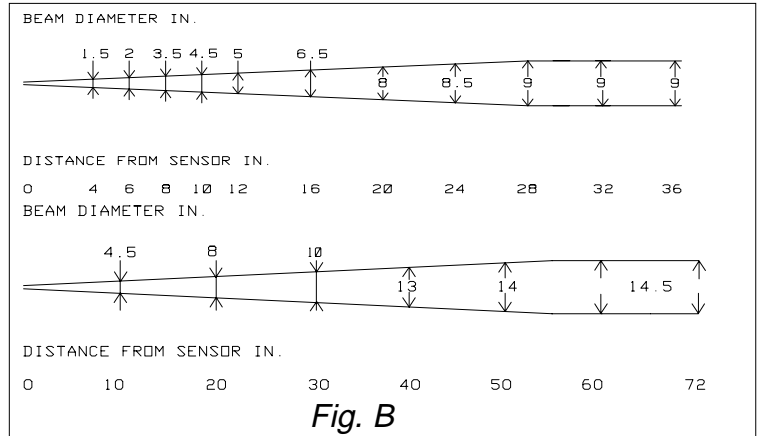
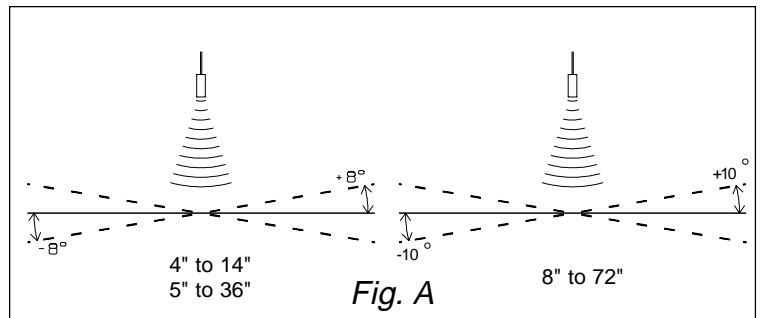

## Figure:

- A - Angle of Tilt
- B - Beam Spread
- C - Wiring Diag.- For RPS-300
- D - Wiring Diag.- For RPS-500
- E - Mounting Dimensions

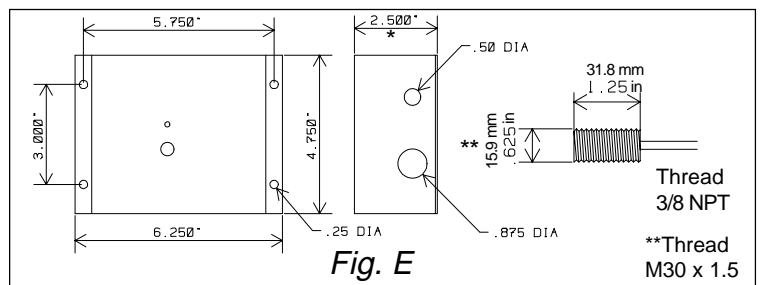

\* Dimension changes from 2.5" to 3.75" when ordered with 500 Analog Ranging card. \*\* Transducer Diameter changes to 30mm when ordered with the Teflon face or in the 72" range.

PART NUMBER	RANGE	OUTPUT
RPS-300-14 RPS-300-36 RPS-300-72	4" - 14" 5" - 36" 8" - 72"	Isolated form C Relay
RPS-300-14-500 RPS-300-36-500 RPS-300-72-500	4" - 14" 5" - 36" 8" - 72"	0 - 10VDC and 4 - 20mA Analog



(815) 338-5800 / FAX: (815) 338-5803

935 Dieckman Rd., Woodstock, IL 60098 USA  
http://www.migatron.com e-mail: info@migatron.com