



RPS-400-30

Features

- Self Contained
- Operates in Hostile Environments
- Sensing Range 5 - 30"
- Operating Voltage 12 - 30VDC
- Narrow Sensing Beam
- NPN Transistor Output
- High Frequency 222kHz
- Externally Adjustable Sensing Range

The RPS-400-30 has a 22mm barrel housing, completely self-contained, 12-30VDC powered ultrasonic proximity sensor. A sealed transducer provides protection in environments where dirt and moisture are a problem. The sensor is constructed of Delrin plastic with a silicon rubber sensing face. This sensor is range or distance sensitive, enabling the sensor to detect objects only within the desired range, and reject objects outside the desired range. The RPS-400-30 is a solid state sensor and has an NPN open collector transistor output. For initial setup purposes, a built in LED indicator illuminates when the ultrasonic wave from the sensor is reflected back to the unit within the preset range. The sensing range is fixed at less than 5 inches by



connecting the green lead to the black lead of the cable; or adjustable up to 30 inches by connecting a resistor/ potentiometer between the green and black leads. The resistor chart on the following page provides resistor values and approximate resulting sensing ranges. These sensors provide precise proximity or level sensing regardless of color, density, or transparency. They are equally effective on liquid, metal, plastic, and glass targets. Standard 6 foot cable is provided. Optional cable lengths are available.

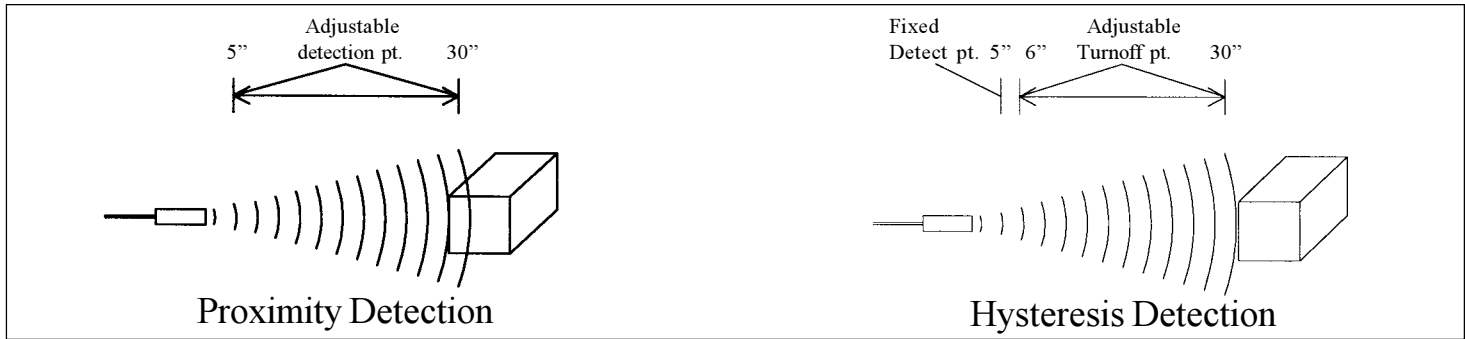

Proximity Detection

Proximity detection is the detection of an object at a given range. The detection range of the RPS-400-30 can be controlled by a resistor or potentiometer wired to the green and black leads of the unit, and is adjustable to the desired detect distance. Any object within the desired range is detected, while objects outside the desired range are ignored. The detect point is independent of size, material, or reflectivity. The proximity option is denoted by the part number RPS-400-30.

Hysteresis Detection

The RPS-400-30 can be furnished with Hysteresis Control capability. The Hysteresis sensor has a fixed detect point equal to the sensors minimum range and an adjustable turnoff point up to the sensors maximum range. Simply stated, an object will be detected at the minimum range, and will remain detected until the object is no longer within the adjustable turnoff point. (See Figure Above). The Hysteresis option is denoted by the part number RPS-400H-30.

SPECIFICATIONS

| | |
|------------------------------|-----------------------------------|
| Operational Range: | Adjustable 5 - 30" |
| Power Input: | 12-30VDC |
| Input Current: | 30mA |
| Ambient Temperature: | 0 - 50°C (32 - 122°F) |
| Humidity: | 0 - 95% Non-Condensing |
| Enclosure: | Delrin with Silicone sensing face |
| Output: | NPN Open Collector Transistor |
| Current Load: | 60mA continuous |
| Transducer Frequency: | 222kHz |
| Response Time: | 30ms - On / 30ms - Off |
| Cycle Rate: | 1000/minute |
| Weight: | 4 ounces |

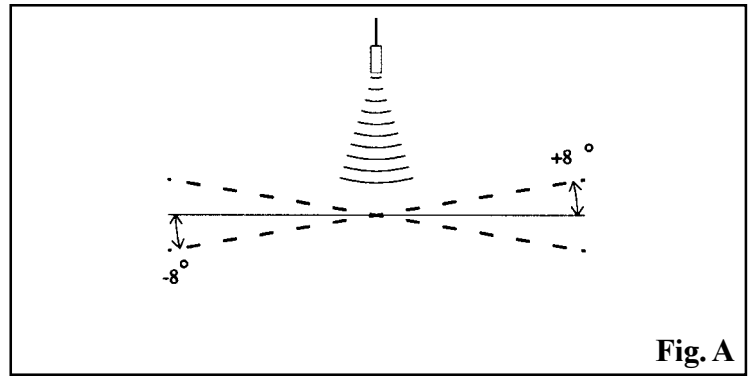

Fig. A

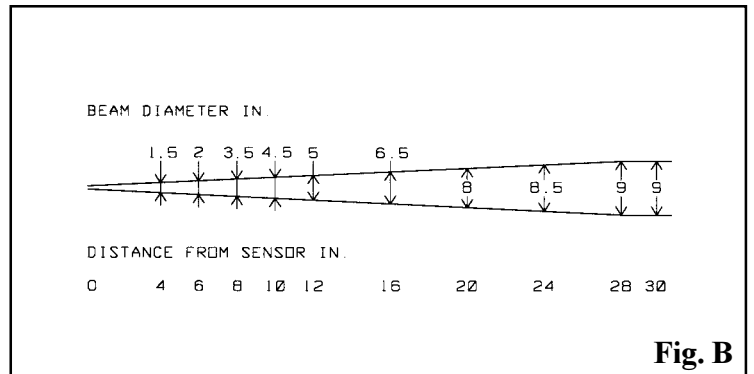

Fig. B

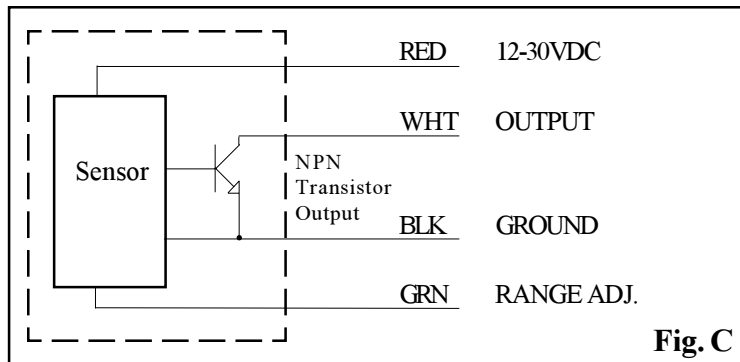

Fig. C

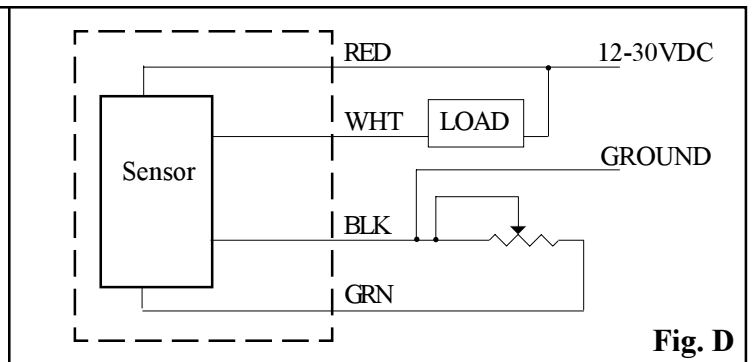

Fig. D

FIGURE:

- A- Angle of Tilt
- B- Beam Spread
- C- Wiring Dia. - Connect to NPN Output
- D- Wiring Dia. - Load and Range Control Pot
- E- Mounting Dimensions

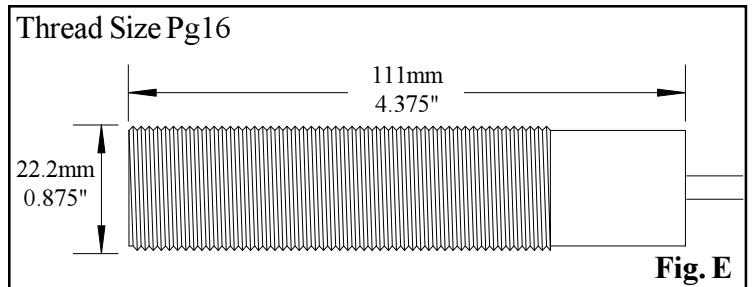

Fig. E

| Resistor Chart | | | | | | | | |
|------------------|-----|-----|-----|-----|------|------|------|------|
| Resistor Value | 10k | 22k | 47k | 68k | 100k | 150k | 220k | 330k |
| Approx. Distance | 5" | 6" | 7" | 9" | 11" | 15" | 20" | 30" |

| PARTNUMBER | RANGE | OUTPUT |
|------------|---------|---------------------------|
| RPS-400-30 | 5 - 30" | NPN Open Collector Output |



Phone: (815) 338-5800 / Fax: (815) 338-5803

935 Dieckman St., Woodstock, IL 60098, U.S.A.
 web: www.migatron.com / e-mail: info@migatron.com