

## MODEL CTD - DC CURRENT TRANSDUCER

- *THREE JUMPER SELECTABLE INPUT RANGES*
- *OUTPUT IS MAGNETICALLY ISOLATED FROM THE INPUT*
- *INTERNAL POWER REGULATION*
- *SPLIT-CORE CASE FOR EASY INSTALLATION*



### GENERAL DESCRIPTION

CTD transducer combines a Hall Effect sensor and a signal conditioner into a single package. This provides higher accuracy, lower wiring costs, easier installation and saves valuable panel space. The CTD has jumper selectable current input ranges and industry standard 4-20 mA output with a split-core case.

### SAFETY SUMMARY

All safety related regulations, local codes and instructions that appear in the literature or on equipment must be observed to ensure personal safety and to prevent damage to either the instrument or equipment connected to it. If equipment is used in a manner not specified by the manufacturer, the protection provided by the equipment may be impaired.

Do not use this unit to directly command motors, valves, or other actuators not equipped with safeguards. To do so, can be potentially harmful to persons or equipment in the event of a fault to the unit.

### SPECIFICATIONS

1. **OUTPUT SIGNAL:** 4-20 mA
2. **OUTPUT LIMIT:** 23 mA
3. **ACCURACY:** 1.0% FS
4. **REPEATABILITY:** 1.0% FS
5. **RESPONSE TIME:** to 90% of step change 100 msec
6. **FREQUENCY RANGE:** DC
7. **POWER SUPPLY:** 22 – 26 VAC/VDC  
 Power input and output signal are not isolated.
8. **POWER CONSUMPTION:** 2 VA
9. **LOADING:** 650Ω max.
10. **ISOLATION VOLTAGE:** 3 kV (monitored line to output)
11. **LINEARITY:** 0.75% FS
12. **CURRENT RANGES:** Three selectable Ranges: 0 – 50 A  
 0 – 75 A  
 0 – 100 A
13. **CASE:** UL 94V-0 Flammability rated thermoplastic
14. **ENVIRONMENTAL:** -4 to 122 °F (-20 to 50 °C)  
 0-95% RH, non-condensing

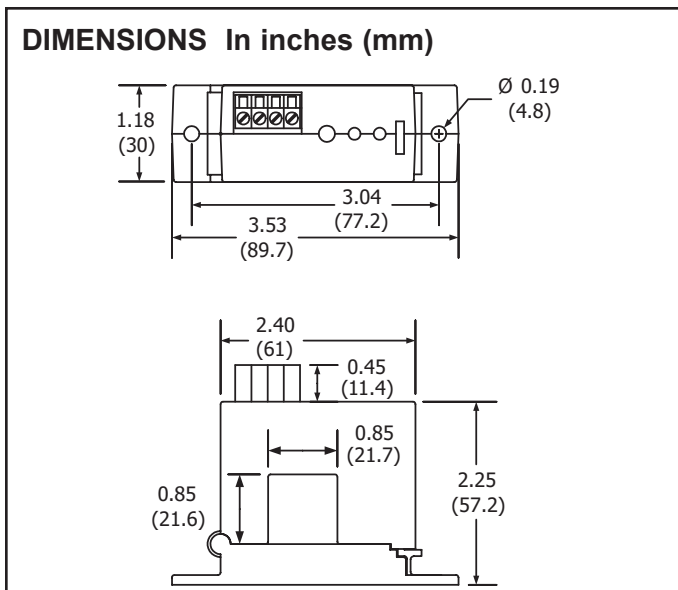
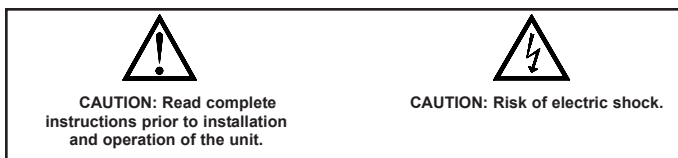

## INSTALLATION

Run wire to be monitored through opening in the sensor. Be sure the monitored current flows in the same direction as the arrow on the sensor. The arrow is just above the hinge, with the “+” symbol on the left, the “-” symbol on the right. The CTD transducers work in the same environment as motors, contactors, heaters, pull-boxes, and other electrical enclosures. They can be mounted in any position or hung directly on wires with a wire tie. Just leave at least one inch (25.4 mm) distance between sensor and other magnetic devices.

### Split-Core Versions

Press the tab in the direction as shown to open the sensor. After placing the wire in the opening, press the hinged portion firmly downward until a definite click is heard and the tab pops out fully.

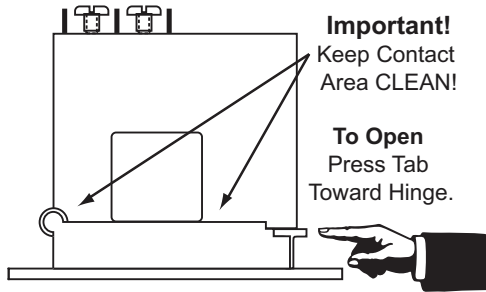

### KEEP SPLIT-CORE SENSORS CLEAN.

Silicone grease is factory applied on the mating surfaces to prevent rust and improve performance. Be careful not to allow grit or dirt onto the grease in the contact area. Operation can be impaired if the mating surfaces do not have good contact. Check visually before closing.

## OUTPUT WIRING

Connect control or monitoring wires to the sensor. Use up to 14 AWG copper wire and tighten terminals to 4 inch-pounds torque.

### 4-20mA:

The current loop is powered by the CTD Transducer.  
Maximum loop impedance is 650 Ω.

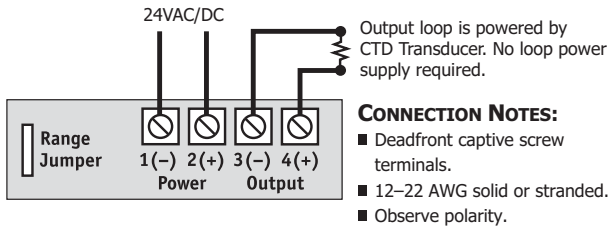

## RANGE SELECT

CTD transducers feature field selectable ranges. The ranges are factory calibrated, eliminating time consuming and inaccurate field setting of zero or span.

1. Determine the normal operating amperage of your monitored circuit.
2. Select the range that is equal to or slightly higher than the normal operating amperage.
3. Place the range jumper in the appropriate position.

## TROUBLE SHOOTING

### 1. Output Signal Too Low

- A. The jumper may be set in a range that is too high for current being monitored. Move jumper to the correct range.
- B. Power supply is inadequate. Check power supply. Make sure it is of sufficient voltage with all loads at maximum. CTD Series draw 2.0 VA.
- C. Output load too high. Check output load, be sure it is no more than 650 Ω.

### 2. Output Signal is always at maximum

- A. The jumper may be set in a range that is too low for current being monitored. Move jumper to the correct range.

### 3. Sensor has no output

- A. Polarity is not properly matched. Check and correct wiring polarity
- B. Monitored load is not DC or is not on. Check that the monitored load is DC and that it is actually on.
- C. Split Core models: The core contact area may be dirty. Open the sensor and clean the contact area.

## ORDERING INFORMATION

MODEL NO.	DESCRIPTION	PART NUMBERS
CTD	DC/DC, Split Case	CTD00000

## LIMITED WARRANTY

The Company warrants the products it manufactures against defects in materials and workmanship for a period limited to two years from the date of shipment, provided the products have been stored, handled, installed, and used under proper conditions. The Company's liability under this limited warranty shall extend only to the repair or replacement of a defective product, at The Company's option. The Company disclaims all liability for any affirmation, promise or representation with respect to the products.

The customer agrees to hold Red Lion Controls harmless from, defend, and indemnify RLC against damages, claims, and expenses arising out of subsequent sales of RLC products or products containing components manufactured by RLC and based upon personal injuries, deaths, property damage, lost profits, and other matters which Buyer, its employees, or sub-contractors are or may be to any extent liable, including without limitation penalties imposed by the Consumer Product Safety Act (P.L. 92-573) and liability imposed upon any person pursuant to the Magnuson-Moss Warranty Act (P.L. 93-637), as now in effect or as amended hereafter.

No warranties expressed or implied are created with respect to The Company's products except those expressly contained herein. The Customer acknowledges the disclaimers and limitations contained herein and relies on no other warranties or affirmations.

Red Lion Controls  
20 Willow Springs Circle  
York PA 17406  
Tel +1 (717) 767-6511  
Fax +1 (717) 764-0839

Red Lion Controls BV  
Basicweg 11b  
NL - 3821 BR Amersfoort  
Tel +31 (0) 334 723 225  
Fax +31 (0) 334 893 793

Red Lion Controls AP  
31, Kaki Bukit Road 3,  
#06-04/05 TechLink  
Singapore 417818  
Tel +65 6744-6613  
Fax +65 6743-3360