

MODEL CUB7 – MINIATURE ELECTRONIC 8 DIGIT COUNTER/TIMER



- 0.35" (8.9 mm) HIGH LCD DIGITS, REFLECTIVE OR TRANSMISSIVE WITH YELLOW/GREEN OR RED BACKLIGHTING (6-26 VDC power supply required for version with LED backlighting)
- INTERNAL LITHIUM BATTERY PROVIDES UP TO 7 YEARS OF TYPICAL UNINTERRUPTED OPERATION
- COUNT SPEEDS UP TO 10KHZ
- 9 PROGRAMMABLE TIME RANGES
- CONTACT, LOGIC, OPEN COLLECTOR, OR HIGH VOLTAGE INPUTS
- STANDARD WIRE CONNECTIONS OR OPTIONAL PLUG-IN TERMINAL BLOCK
- NEMA 4X/IP65 SEALED FRONT BEZEL THAT FITS 1/32 DIN CUT-OUT

DESCRIPTION

The CUB7 series is an 8-digit lithium battery powered miniature counter or timer with large 0.35" (8.9 mm) high digits. It has an LCD read-out available in Positive Image Reflective, Negative Image Transmissive with yellow/green or red backlighting. The backlight versions require an external 6-26 VDC power supply. The CUB7 series is housed in a lightweight, high impact plastic case with a clear viewing window. The sealed front panel with silicon rubber keypad meets NEMA 4X/IP65 specification for wash-down and/or dusty environments, when properly installed with supplied panel gasket and mounting clip.

Both counter and timer CUB7 models are available with a low voltage input (28 VDC max) or an isolated high voltage input (50-250 VDC/VAC). The low voltage input has DIP switch selections for SINKING or SOURCING along with a HIGH/LOW FREQUENCY selection (low frequency for contact inputs). Both units have front panel keypads that can be used to reset the display. The keypad can be enabled/disabled via a single DIP switch. The standard unit uses 22 gauge wires for external connections, an optional plug-in terminal block is available.

SAFETY SUMMARY

All safety related regulations, local codes and instructions that appear in the literature or on equipment must be observed to ensure personal safety and to prevent damage to either the instrument or equipment connected to it. If equipment is used in a manner not specified by the manufacturer, the protection provided by the equipment may be impaired.

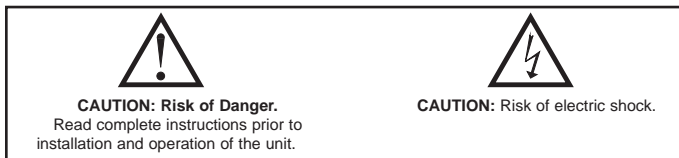

SPECIFICATIONS

1. **DISPLAY:** 8-digit LCD, 0.35" (8.90 mm) high digits
2. **POWER:** Non-replaceable internal 3.6 VDC lithium battery provides 7 years of typical continuous operation (high count speeds in SNK mode & extreme ambient temperatures will decrease battery life, use of SRC mode can extend battery life)
OPTIONAL LED BACKLIGHT POWER: 6-26 VDC @ 25 mA max.
3. **LOW VOLTAGE INPUT:**
 SNK mode (DIP switch 1 off) internal pull-up to battery
 V_{IN} High Min = 1.5 VDC
 V_{IN} Low Max = 0.5 VDC
 I_{IN} Max = 5 μ A
 V_{IN} Max = 3.6 VDC
 SRC mode (DIP switch 1 on) internal pull-down to common
 V_{IN} High Min = 1.5 VDC
 V_{IN} Low Max = 0.5 VDC
 I_{IN} Max = 5 mA
 V_{IN} Max = 28 VDC
COUNT SPEED:
 HIGH FREQUENCY mode (DIP switch 2 off): 10 kHz max (SRC mode) with 50% duty cycle
 LOW FREQUENCY mode (DIP switch 2 on): 30 Hz max with 50% duty cycle
 Note: Count input counts on negative edge
 Timer runs when input is low.
4. **HIGH VOLTAGE INPUT:**
 V_{IN} Range = 50-250 VDC/VAC 50/60 Hz, 5 mA max
 Isolation: 2500 VAC 1 min
 Note: Count input adds one count with voltage present
 Timer runs when voltage present
5. **RESET INPUT:**
 V_{IN} Low Max = 1.5 VDC (internal pull-up to battery)
 I_{IN} Max = 20 μ A
 5 msec min (active low)
 Note: Reset input is active low to clear display to zero

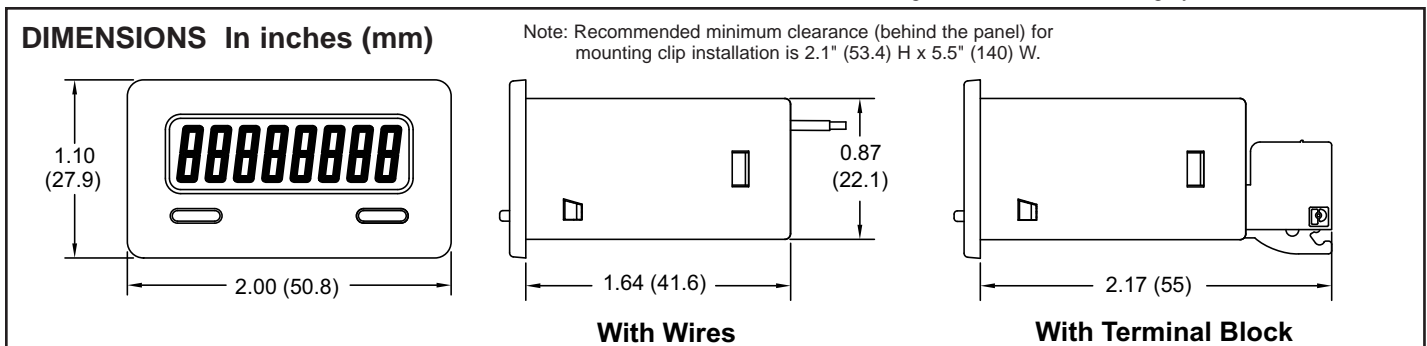

6. **TIMER ACCURACY:** 0.025%
7. **ENVIRONMENTAL CONDITIONS:**
 Operating Temperature: 0 to 50 °C
 Storage Temperature: -30 to 80 °C
 Operating and Storage Humidity: 85% max. (non-condensing)
8. **CERTIFICATIONS AND COMPLIANCES:**
 Contact the factory for EMC specifications.
 Refer to the EMC Installation Guidelines section of this bulletin for additional information.

9. **CONNECTIONS:** 22 gauge wire, wire length minimum 10"
10. **CONSTRUCTION:** High impact plastic case with clear viewing window.
 The front panel meets NEMA 4X/IP65 requirements for indoor use when properly installed. Installation Category II, Pollution Degree 2. Panel gasket and mounting clip are included.
11. **WEIGHT:** 0.11 lbs. (0.05 Kg)

ORDERING INFORMATION

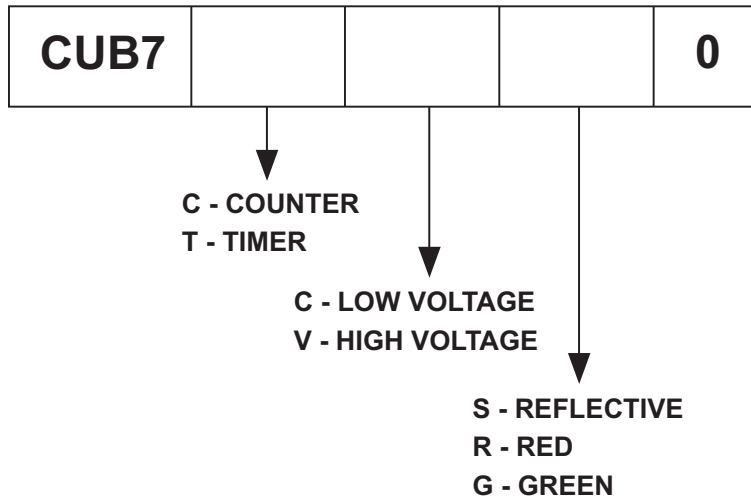

Accessories Part Numbers

TYPE	DESCRIPTION	PART NUMBER	USED WITH
Plug-in Terminal Block	3 Position Terminal Block	TB100003	CUB7CCS0, CUB7TCS0
	4 Position Terminal Block	TB100004	CUB7CCG0, CUB7TCG0, CUB7CCR0, CUB7TCR0, CUB7CVS0, CUB7TVS0
	5 Position Terminal Block	TB100005	CUB7CVG0, CUB7TVG0, CUB7CVR0, CUB7TVR0
Enclosure	CUB7 Enclosure	ENC13000	
Base Mount	CUB7 Base Mount	BMK80000	

See Wiring the Meter section to determine the terminal block needed.

1.0 INSTALLING THE METER

INSTALLATION ENVIRONMENT

The unit should be installed in a location that does not exceed the maximum operating temperature and provides good air circulation. Placing the unit near devices that generate excessive heat should be avoided.

The bezel should be cleaned only with a soft cloth and neutral soap product. Do NOT use solvents.

Continuous exposure to direct sunlight may accelerate the aging process of the bezel. Do not use tools of any kind (screwdrivers, pens, pencils, etc.) to operate the keypad of the unit.

Installation

The CUB7 series of products meets NEMA 4X/IP65 requirements for indoor use, when properly installed. The units are intended to be mounted into an enclosed panel. The viewing window and reset button are factory sealed for a washdown environment. A sponge rubber gasket and mounting clip are provided for installing the unit in the panel cut-out.

The following procedure assures proper installation:

1. Cut panel opening to specified dimensions. Remove burrs and clean around panel opening.
2. Carefully remove and discard the center section of the gasket. Slide the panel gasket over the rear of the unit to the back of the bezel. Insert the mounting screws onto both sides of mounting clip. The tip of the screw should **NOT** project from the hole in the mounting clip.
3. Install the CUB7 unit through the panel cut-out until the front bezel flange contacts the panel.
4. Slide the mounting clip over the rear of the unit until the clip is against the back of the panel. The mounting clip has latching features which engage into mating features on the CUB7 housing.
5. Alternately tighten each screw to ensure uniform gasket pressure. Visually inspect the front panel gasket. The gasket should be compressed to about 75 to 80% of its original thickness. If not, gradually turn mounting screws to further compress gasket.
6. If gasket is not adequately compressed and the mounting screws can no longer be turned, loosen mounting screws, and check that mounting clip is latched as close as possible to the panel.
7. Repeat from step #5 for tightening mounting screws.

Note: It is necessary to hold the unit in place when sliding mounting clip into position.

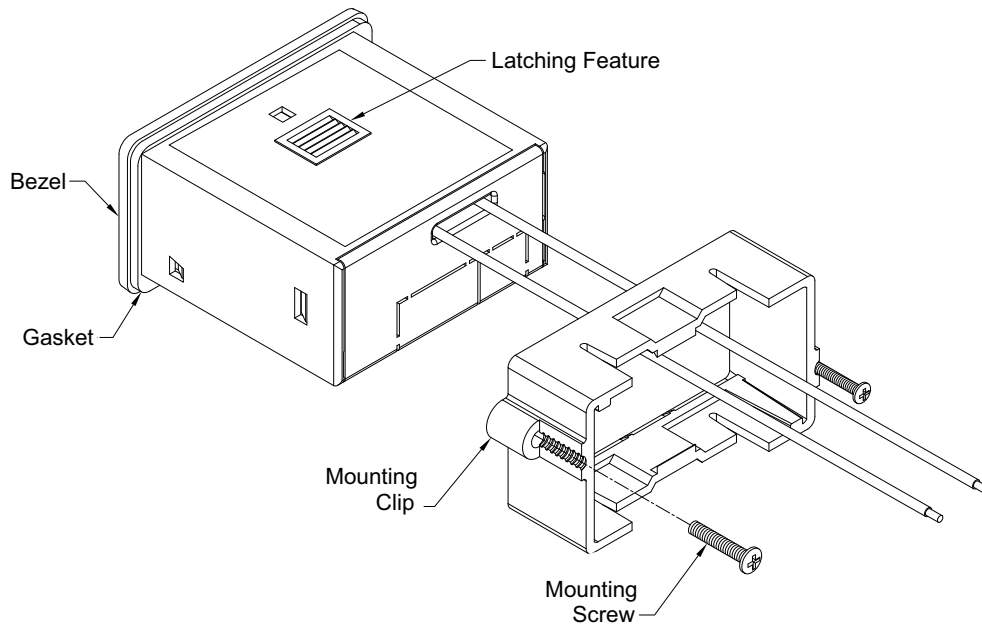
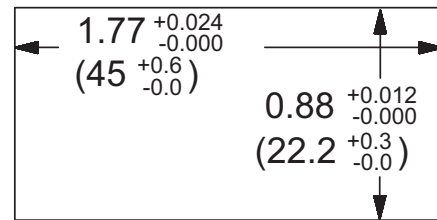

2.0 SETTING THE DIP SWITCHES

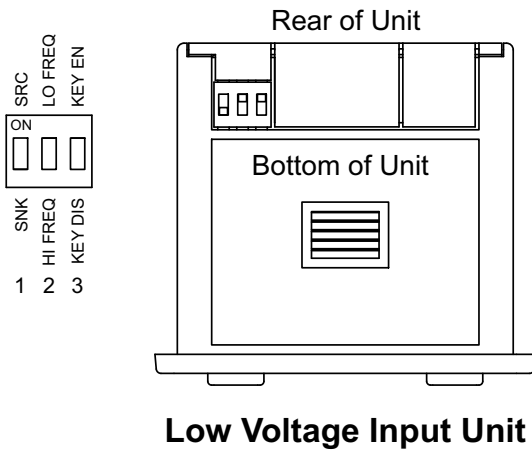

Low voltage input units have 3 DIP switches that must be positioned appropriately prior to wiring.

Note: Placing the KEY DISABLE/ENABLE DIP switch in the OFF position, disables all front panel keys.

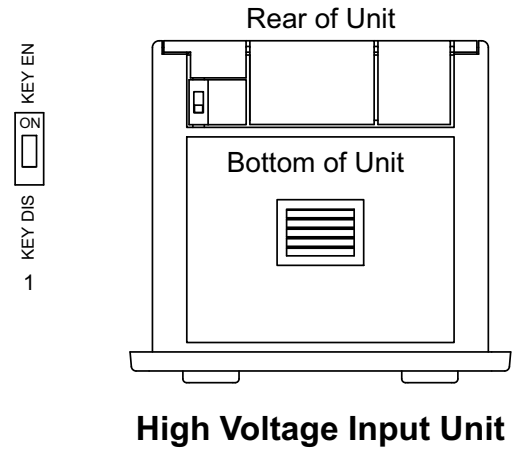

High voltage input units have 1 DIP switch to enable or disable the front bezel keypad.

3.0 PROGRAMMING THE TIME RANGE

The CUB7 Timer has 9 time ranges. To change ranges, enable the front keypad with the DIP switch and press the SEL key. The currently programmed time range will be displayed (example 222222.2 = time range 2). To change the range, press the RST key. The ranges will cycle from 0-8 and back to 0. To enter your time range, press the SEL key and the unit will retain the current time range and return back to normal.

DISPLAY DURING PROGRAMMING	TIMER RANGE
00000.000	0.001 SEC
111111.11	0.01 SEC
222222.2	0.1 SEC
333333333	1 SEC
4444444.4	0.1 MIN
555555555	1 MIN
666666.66	0.01 HR
7777777.7	0.1 HR
88888888	1 HR

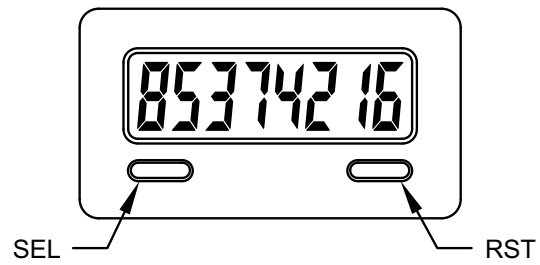

4.0 RESETTING THE DISPLAY

The display may be reset to zero via the front RST key, the remote reset input or both.

The front RST key must be enabled for front panel reset. DIP switch # 3 on the low voltage input units or the single DIP switch on the high voltage input units. (See 2.0 Setting the DIP Switches for switch location)

The remote reset is activated via an external momentary contact closure between the reset input (blue wire) and the common (black wire). When the optional terminal blocks are used, see 5.0 Wiring The Meter, for the appropriate reset input terminal and the common terminal.

5.0 WIRING THE METER

WIRING OVERVIEW

Electrical connections are made to the #22 AWG colored wires protruding from the rear of the unit. When using the optional terminal block, the #22 AWG colored wires are cut off and electrical connections are made via screwless type terminal block. All conductors should conform to the meter's voltage and current ratings. All cabling and wire terminations should conform to appropriate standards of good installation, local codes and regulations. It is recommended that the backlight power supplied to the meter (DC or AC) be protected by a fuse or circuit breaker.

EMC INSTALLATION GUIDELINES

Although this meter is designed with a high degree of immunity to Electro-Magnetic Interference (EMI), proper installation and wiring methods must be followed to ensure compatibility in each application. The type of the electrical noise, source or coupling method into the meter may be different for various installations. The meter becomes more immune to EMI with fewer I/O connections. Cable length, routing, and shield termination are very important and can mean the difference between a successful or troublesome installation. Listed below are some EMC guidelines for successful installation in an industrial environment.

1. The meter should be mounted in a metal enclosure, which is properly connected to protective earth.
2. Use shielded (screened) cables for all Signal and Control inputs. The shield (screen) pigtail connection should be made as short as possible. The connection point for the shield depends somewhat upon the application. Listed below are the recommended methods of connecting the shield, in order of their effectiveness.
 - a. Connect the shield only at the panel where the unit is mounted to earth ground (protective earth).
 - b. Connect the shield to earth ground at both ends of the cable, usually when the noise source frequency is above 1 MHz.
 - c. Connect the shield to common of the meter and leave the other end of the shield unconnected and insulated from earth ground.

3. Never run Signal or Control cables in the same conduit or raceway with AC power lines, conductors feeding motors, solenoids, SCR controls, and heaters, etc. The cables should be ran in metal conduit that is properly grounded. This is especially useful in applications where cable runs are long and portable two-way radios are used in close proximity or if the installation is near a commercial radio transmitter.
4. Signal or Control cables within an enclosure should be routed as far as possible from contactors, control relays, transformers, and other noisy components.
5. In extremely high EMI environments, the use of external EMI suppression devices, such as ferrite suppression cores, is effective. Install them on Signal and Control cables as close to the unit as possible. Loop the cable through the core several times or use multiple cores on each cable for additional protection. Install line filters on the power input cable to the unit to suppress power line interference. Install them near the power entry point of the enclosure. The following EMI suppression devices (or equivalent) are recommended:
 - Ferrite Suppression Cores for signal and control cables:
 - Fair-Rite # 0443167251 (RLC# FCOR0000)
 - TDK # ZCAT3035-1330A
 - Steward # 28B2029-0A0
 - Line Filters for input power cables:
 - Schaffner # FN610-1/07 (RLC# LFIL0000)
 - Schaffner # FN670-1.8/07
 - Corcom # 1 VR3

Note: Reference manufacturer's instructions when installing a line filter.
6. Long cable runs are more susceptible to EMI pickup than short cable runs. Therefore, keep cable runs as short as possible.
7. Switching of inductive loads produces high EMI. Use of snubbers across inductive loads suppresses EMI.
 - Snubber: RLC# SNUB0000.

USING THE COLOR CODED WIRES

The low voltage input units will contain three or four color coded wires depending on the backlight power requirements.

The high voltage input units will contain (2) orange wires and an additional two or three wires depending on the backlight power requirements.

The tables define the function of each colored wire.

LOW VOLTAGE INPUT

Wire Colors

WHITE	BLUE	BLACK	RED
Low Voltage Input	Reset	Common	+Backlight Power

HIGH VOLTAGE INPUT

Wire Colors

ORANGE	ORANGE	BLUE	BLACK	RED
High Voltage Input	High Voltage Input	Reset	Common	+Backlight Power

USING THE OPTIONAL TERMINAL BLOCK

1. Remove the rear cover. Refer to Figure 1. A small slotted screwdriver is required to release the side latches. Insert the screwdriver tip between the rear cover and the side of the unit. Leverage the screwdriver away from the case to unlatch the side latch and slightly lift the rear cover. Pinch the corners to hold the rear cover in place. Remove the screwdriver and repeat the same procedure on the other side of the rear cover.
2. For safety concerns, the wires should be cut off completely flush with the PC board to prevent a short.
3. Break out the break away tab(s) as required. Remove the left tab only for 3 position terminal block or both tabs for 4 and 5 position terminal blocks.
4. Reinstall the rear cover into CUB7 unit.
5. Mount the CUB7 into the panel (refer to 1.0 Installing The Meter)
6. Push the keyed terminal block onto the exposed PC board. The left most terminal, next to the DIP switch(s) is terminal #1.

Note: Wire sizes 16-24 AWG may be used with 0.25" length exposed. The screwless type terminal block requires a small slotted screwdriver engaged in the upper slot to open the wire clamp in the lower larger slot. Removing the screwdriver will lock the wire clamp onto the wire.

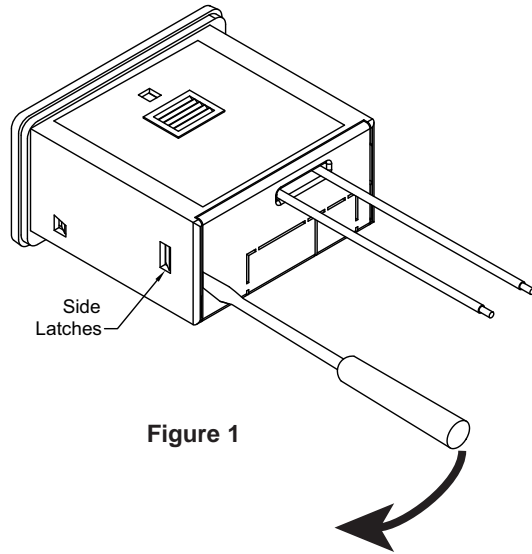
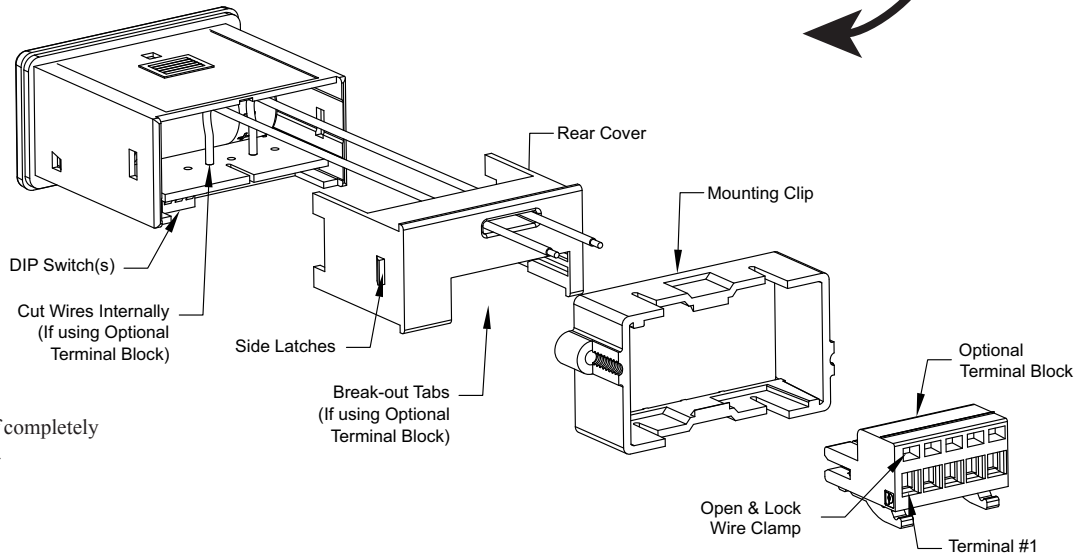
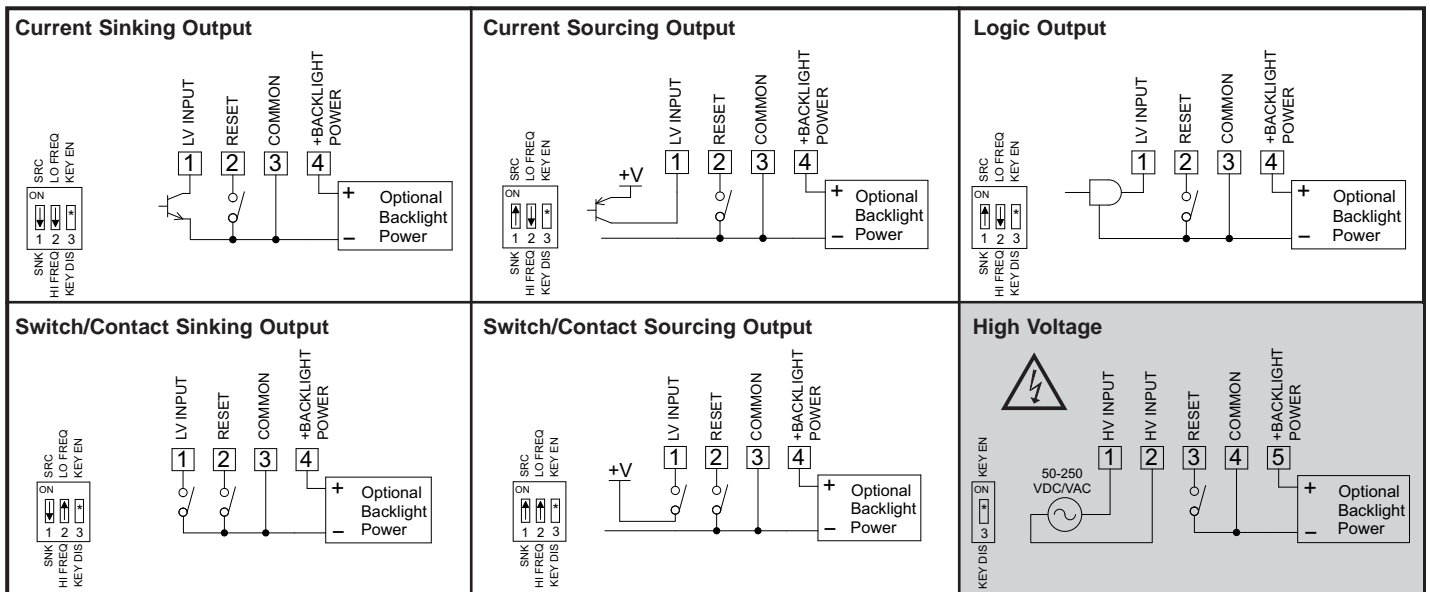

Figure 1



Wires must be cut off completely flush with PC board.



* Switch position is application dependent.

Shaded area for high voltage applications.

This page intentionally left blank.

LIMITED WARRANTY

The Company warrants the products it manufactures against defects in materials and workmanship for a period limited to two years from the date of shipment, provided the products have been stored, handled, installed, and used under proper conditions. The Company's liability under this limited warranty shall extend only to the repair or replacement of a defective product, at The Company's option. The Company disclaims all liability for any affirmation, promise or representation with respect to the products.

The customer agrees to hold Red Lion Controls harmless from, defend, and indemnify RLC against damages, claims, and expenses arising out of subsequent sales of RLC products or products containing components manufactured by RLC and based upon personal injuries, deaths, property damage, lost profits, and other matters which Buyer, its employees, or sub-contractors are or may be to any extent liable, including without limitation penalties imposed by the Consumer Product Safety Act (P.L. 92-573) and liability imposed upon any person pursuant to the Magnuson-Moss Warranty Act (P.L. 93-637), as now in effect or as amended hereafter.

No warranties expressed or implied are created with respect to The Company's products except those expressly contained herein. The Customer acknowledges the disclaimers and limitations contained herein and relies on no other warranties or affirmations.

Red Lion Controls
Headquarters
20 Willow Springs Circle
York PA 17406
Tel +1 (717) 767-6511
Fax +1 (717) 764-0839

Red Lion Controls
Europe
Printerweg 10
NL - 3821 AD Amersfoort
Tel +31 (0) 334 723 225
Fax +31 (0) 334 893 793

Red Lion Controls
India
54, Vishvas Tenement
GST Road, New Ranip,
Ahmedabad-382480 Gujarat, India
Tel +91 987 954 0503
Fax +91 79 275 31 350

Red Lion Controls
China
Unit 101, XinAn Plaza
Building 13, No.99 Tianzhou Road
ShangHai, P.R. China 200223
Tel +86 21 6113-3688
Fax +86 21 6113-3683