

GEMINI 3300 - 6-DIGIT PRESETTABLE BATCH COUNTER



- 6-DIGIT, 0.56" (14.2 mm) HIGH LED DISPLAY WITH NEGATIVE SIGN, OVERFLOW AND DISPLAY MODE INDICATORS
- 3 DISPLAYABLE COUNT VALUES (Process, Batch, Total)
- 3 PRESETS - 2 PROCESS AND 1 BATCH
- SERIAL COMMUNICATIONS OPTION
- INPUT SCALING
- ACCEPTS INPUT COUNT RATES UP TO 10 KHz
- BI-DIRECTIONAL COUNTING, UP/DOWN CONTROL
- ANTI-COINCIDENCE COUNT MODES
- QUADRATURE SENSING (Up to 4 Times Resolution)
- SOLID-STATE CURRENT SINKING OUTPUTS
- RELAY OUTPUTS (PROCESS) (Field Replaceable)
- PROGRAMMABLE TIMED OUTPUTS (0.01 sec. to 599.99 sec.)
- NON-VOLATILE MEMORY (E²PROM)
- SEALED FRONT PANEL CONSTRUCTION (NEMA 4/IP65)
- ABILITY TO LOCK OUT FRONT PANEL FUNCTIONS
- COUNT VALUE CAN BE CHANGED VIA FRONT PANEL
- PROGRAMMABILITY OF DECIMAL POINT LOCATION AND LEADING ZERO BLANKING

DESCRIPTION

The GEMINI 3300 is an extremely versatile unit that offers the user flexibility in batch counting applications. The unit features three integrated counters in one package; a Process Counter, a Batch Counter, and a Totalizing Counter. The Process Counter is used to monitor the progress of the count within the Batch. The Process Counter has 2 Presets associated with it, Preset 1 & Preset 2. Preset 1 is typically used as a "slow-down" output in cut-to-length applications. When the Process Counter reaches Preset 2 or zero (in Reset To Preset modes), the Process Counter will increment or decrement the Batch Counter and activate Output 2, and Relay 2 (optional). When the Batch Count equals the Batch Preset or Zero, the Batch output, Output B (Solid-state only), will activate. The Process and Batch count can be independently programmed to auto-cycle back to zero (or Preset) or be programmed for manual Reset To Zero (or Preset) operation. The Totalizing Counter increments for every Process Count received. It can be used as a running total per shift, day, etc.

The GEMINI 3300 offers a choice of programmable Input Response Modes to cover bi-directional, anti-coincidence, and quadrature applications. The input circuitry is switch selectable to accept signals from a wide variety of sources. The unit may be programmed to register counts on both edges of the input signal thus providing frequency doubling capability. Several reset cycle modes, along with the compatibility of count and control inputs to other RLC products, provides added versatility for both stand-alone and system counter requirements.

There are two ways to reset the count values of the GEMINI 3300. One method is with the Reset pushbutton or rear terminal which will reset the counters as selected in the programming of the Reset Button and Terminal Actuation Modes. The second method is available to provide means to reset each count individually. This method requires pressing two pushbuttons. First press and hold the "E" button, then press the "I" button for Process Count, or the "2" button for Batch Count.

A "Counter Load" feature is provided which allows changing any of the three count values utilizing the front panel pushbuttons.

The GEMINI 3300 20 mA Current Loop Communications option provides the capability of two-way serial communications between the GEMINI 3300 and a variety of equipment, such as a printer, remote terminal, programmable

controller, or host computer. The baud rate can be set to 300, 600, 1200, or 2400 baud. The format for transmitted and received data is 1 start bit, 7 data bits, 1 parity bit (odd), and a stop bit. When utilizing an external power supply (30 VDC max), up to sixteen units can be installed in the loop, each with an individual address. When utilizing the Gemini's 20 mA current source, up to seven units can be installed in a loop. The Count Values, Presets, and Scale Factor can be interrogated or changed by sending the proper command codes and numerical data (if required) to the unit. Other functions, such as resetting the various counters, can also be performed. Various "Print Options" can be selected to automatically interrogate the Count Values, Presets, and Scale Factor by activating the "Print Request" terminal or by sending a "Transmit Per Print Option" (P) command.

The construction of the GEMINI 3300 features a metal die-cast bezel offering maximum durability with a high quality appearance. The sealed front panel bezel meets NEMA 4/IP65 specifications for wash-down and/or dust when properly installed. Electrical connections are made via plug-in terminal strips. Clamp-type pressure plate terminals accept stripped #14 AWG wire without lugs.

SPECIFICATIONS

1. **DISPLAY:** 6-digit 0.56" (14.2 mm) High LED display.
2. **POWER REQUIREMENTS:**
AC Power: Switch selectable 115/230 VAC (±10%), 50/60 Hz, 20 VA
DC Power: 11 to 14 VDC @ 0.7 amp max.
3. **SENSOR POWER:** +12 VDC (±25%) @ 100 mA.
4. **MEMORY:** Non-volatile E²PROM memory retains all programming information, count values, and Counter Load Values when power is removed or interrupted.
Power Cycles (ON/OFF): 100,000 min.
Data Retention: 10 yrs min.
5. **INPUTS A AND B:** Switch selectable to accept count pulses from a variety of sources including switch contacts, outputs from CMOS or TTL circuits, and all standard RLC sensors.
Current Sourcing: Unit provides pull-down resistor for sensors with current sourcing output. (Max. input voltage = 28 VDC @ 7 mA.)

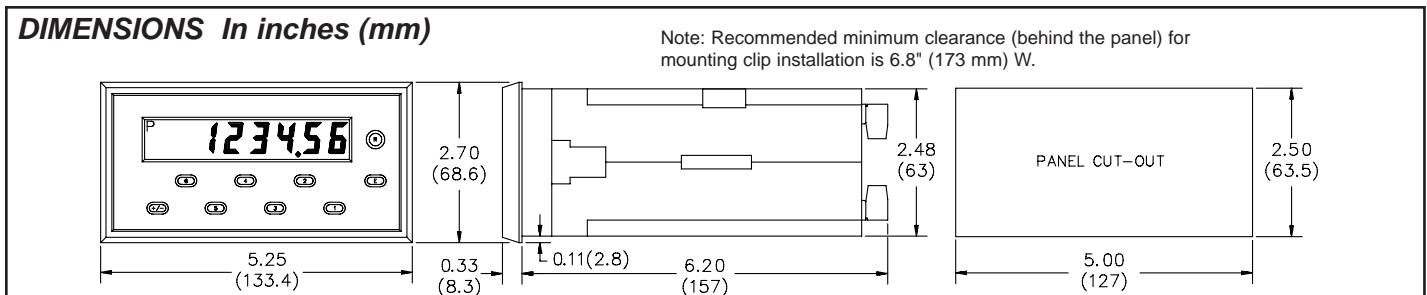

Current Sinking: Unit provides pull-up load for sensors with current sinking output. (Max. sensor current = 1.6 mA.)

Debounce: Damping capacitor provided for switch contact debounce. Limits count speed to 100 Hz max. with 50% duty cycle.

Lo Bias: Input trigger levels $V_{IL} = 1.5\text{ V}$, $V_{IH} = 3.75\text{ V}$.

Hi Bias: Input trigger levels $V_{IL} = 5.5\text{ V}$, $V_{IH} = 7.5\text{ V}$.

Note: Bias levels given are $\pm 10\%$ @ 12 VDC. They vary proportionally with sensor supply voltage at "DC OUT" terminal.

6. MAGNETIC PICKUP INPUT:

Sensitivity: 150 mV peak (typical @ 12 VDC)

Hysteresis: 100 mV

Input Impedance: 26.5 K Ω @ 60 Hz

Maximum Input Voltage: $\pm 50\text{ V}$ peak

7. MAXIMUM COUNT RATES:

| MODE | X1 | X2 | X4 |
|------------------------|----------|----------|-------|
| Uni- or Bi-Directional | 10 KHz | 6.5 KHz | |
| Anti-Coincidence | 9 KHz | 5 KHz | |
| Quadrature | 4.25 KHz | 4.25 KHz | 3 KHz |

8. CONTROL INPUTS:

Reset - Active low ($V_{IL} = 1.5\text{ V}$ max.) internally pulled up to +12 VDC ($I_{SNK} = 3\text{ mA}$), activation and deactivation response time = 10 msec.

Program Disable - Active low ($V_{IL} = 1.5\text{ V}$ max.) internally pulled up to +5 VDC ($I_{SNK} = 1\text{ mA}$).

Print Request - (GEM331XX only) Active low ($V_{IL} = 1.5\text{ V}$ max.) internally pulled up to +5 VDC ($I_{SNK} = 1\text{ mA}$).

9. SERIAL COMMUNICATIONS (Optional):

Type - Bi-directional 20 mA current loop, 20 mA source provided. (*Powers up to seven units in a loop with internal current source.*)

Baud Rate - Programmable 300 to 2400.

Maximum Address - 16 units (0 to 15). (*Actual number in a single loop is limited by serial hardware specifications.*)

Data Format - 1 bit frame, Odd parity (*one start bit, 7 data bits, one odd parity bit, and one stop bit.*)

Serial Hardware Specifications -

SO - Output Transistor Rating: $V_{MAX} = 30\text{ VDC}$,

$V_{SAT} = 1\text{ V}_{MAX}$ @ 20 mA. (*Can address 16 units in a loop*)

SI - Input Diode Rating: $V_F = 1.25\text{ V}_{TYP}$; 1.5 V_{MAX}

Note: The compliance voltage rating of the source must be greater than the sum of the voltage drops around the loop.

10. OUTPUT(S):

Solid-State - Current sinking NPN Open Collector Transistors. $I_{SNK} = 100\text{ mA}$ max. @ $V_{CE} = 1\text{ V}$. $V_{OH} = 30\text{ VDC}$ max. (*Internal Zener diode protection.*)

Relays - Mounted on a field-replaceable PC board. Form C contacts rated at 5 amps @ 120/240 VAC or 28 VDC (*resistive load*), 1/8 H.P. @ 120 VAC (*inductive load*).

Relay Life Expectancy - 100,000 cycles at max. rating. (*As load level decreases, life expectancy increases.*)

Programmable Timed Outputs - The timed outputs can be set from 0.01 to 599.99 seconds, $\pm(0.05\% + 10\text{ msec.})$.

11. CERTIFICATIONS AND COMPLIANCES:

SAFETY:

IEC 1010-1, EN 61010-1: Safety requirements for electrical equipment for measurement, control and laboratory use, Part 1.

IP65 Enclosure rating (Face only), IEC 529

Type 4 Enclosure rating (Face only), UL50

ELECTROMAGNETIC COMPATIBILITY:

Immunity to EN 50082-2

Electrostatic discharge EN 61000-4-2 Level 2; 4 Kv contact¹
Level 3; 8 Kv air

Electromagnetic RF fields EN 61000-4-3 Level 3; 10 V/m
80 MHz - 1 GHz

Fast transients (burst) EN 61000-4-4 Level 4; 2 Kv I/O
Level 3; 2 Kv power²

RF conducted interference EN 61000-4-6 Level 3; 10 V/rms
150 KHz - 80 MHz

Power frequency magnetic fields EN 61000-4-8 Level 4; 30 A/m

Emissions to EN 50081-2

RF interference EN 55011 Enclosure class A
Power mains class A

Notes:

1. Metal bezel of unit connected with ground lead from rear bezel screw to metal mounting panel.

2. When the unit is DC powered, a power line filter (RLC# LFIL0000 or equivalent) was installed, so as not to impair the function of the unit.

Refer to the EMC Compliance Installation section of the manual for additional information.

12. ENVIRONMENTAL CONDITIONS:

Operating Temperature: 0 to 50°C

Storage Temperature: -40 to 70°C

Operating and Storage Humidity: 85% max. relative humidity (non-condensing) from 0 to 50°C.

Altitude: Up to 2000 meters

13. CONSTRUCTION:

Metal die-cast bezel, plastic case. This unit is rated for NEMA 4/IP65 indoor use. Installation Category II, Pollution Degree 2

14. **WEIGHT:** 2.1 lbs. (0.9 kg)

PROGRAMMABLE FUNCTIONS

PRESET(S)

Range 0 to 999999

SCALE FACTOR

5-digit input scaling, 0.0001 to 5.9999 (*Process and total counters*).

SCALE MULTIPLIER

Multiplies the contents of the 9-digit internal Process and Total Counters by a factor of 1, 0.1, 0.01, or 0.001 to view the desired number of significant digits on the display.

INPUTS A & B RESPONSE MODES

Count (A) with Inhibit (B)

Count (A) with UP/DN Control (B)

2-Input Anti-coincidence Counting

Quadrature

FREQUENCY DOUBLING

Registers counts on both edges of input signal.

RESET ACTION (Automatic and Manual)

Reset-to-Zero: Output activates when counter equals the Preset value, counter returns to zero when reset.

Reset-to-Preset: Output activates when counter equals zero, counter returns to Preset value when reset.

RESET BUTTON AND TERMINAL ACTUATION MODES

Selects which counters will be reset when Reset button or terminal is activated.

2-BUTTON RESET

Allows individual counters to be reset independently, regardless of the Manual Reset mode selected.

COUNTER LOAD VALUE

Allows counter values to be changed via the front panel.

DECIMAL POINT AND LEADING ZERO BLANKING

Decimal point programmable to desired location. Leading zero blanking, when selected, begins with second digit to the left of the decimal point.

PROCESS OUTPUT 1 & 2 TERMINATION MODES

Terminate At "Other" Output Start

Terminate At "Other" Output End

Terminate At Manual Reset

Terminate At Manual Reset End

Terminate After Timed Output

BATCH OUTPUT TERMINATION MODES

Terminate At Manual Reset

Terminate At Manual Reset End

Terminate After Timed Output B

TIMED OUTPUTS

Programmable from 0.01 to 599.99 seconds. Accurate to $\pm(0.05\% + 10\text{ msec.})$.

FRONT PANEL LOCKOUT MODES

When the "Program Disable" control input is activated, the ability to change front panel programmed functions will be prevented as per the following modes:

Complete Front Panel Disable

Presets Enabled Only

Scale Factor Enabled Only

Both Presets and Scale Factor Enabled

Presets, Counter Load Values And 2-Button Reset Enabled

Presets, Counter Load Values, Scale Factor And 2-Button Reset Enabled

Note: In all the modes above, the Reset ("R") button and terminal can be enabled or disabled. The reset ("R") button may be disabled independently by the setting of a DIP switch.

SELF-TEST

Performs a complete check on the display and output circuitry along with a functional check on the microprocessor circuitry. Self-test is non-destructive and may be performed during a process without losing counts.

PROGRAMMING

The GEMINI 3300 input circuit set-up is programmed using DIP switches on the rear of the unit. All other functions are programmed through the front panel pushbuttons.

To program or interrogate a function, the user first enters a two-digit function code. The unit will then display that function code along with a single digit representing the present mode of operation. Programming changes are made by changing the single-digit mode identifier.

EXAMPLE: The function code representing the "Inputs A and B Response Modes" is 43. The mode identifiers for this function are:

- 1) Count (A) with Inhibit (B)
- 2) Count (A) with Up/Down Control (B)
- 3) 2-Input Anti-Coincidence Add (A)/Subtract (B)
- 4) 2-Input Anti-Coincidence Summing
- 5) Quadrature
- 6) Quadrature X 4

To interrogate the counting modes, press 43:
Unit displays the function code along with mode identifier 1 (Count with inhibit).

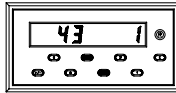

To change the counting mode to "Count with UP/DN control", press 2:

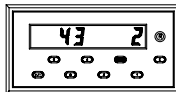

To enter and save the new mode, Press "E":
Unit enters new mode and returns display to the present count value.

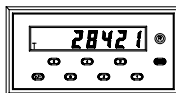

The GEMINI 3300 can display any of the three count values: The Process (P) Count, the Batch (B) Count, or the Total (T) Count.

Three indicator LEDs along the left side of the window indicate which count is currently being displayed.

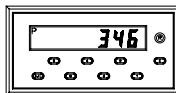

To display a different count value:
Press the "+/-" pushbutton repeatedly until the indicator corresponding to the desired count turns on.

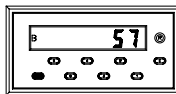

The most commonly used functions, Presets and Scale Factor, have dedicated pushbuttons associated with them. When the Process Count is on the display, pressing "1" or "2" will display Preset 1 or 2. When the Batch Count is on the display, pressing "1" will display the Batch Preset. Pressing the "3" key when viewing any count value, will display the Scale Factor. To change any digit of that value, the user presses the pushbutton directly below that particular digit, which is then scrolled until the desired value is obtained. Each digit is changed, if necessary, in the same manner until the complete Preset or Scale Factor value is registered on the display. Pressing the "E" pushbutton completes the entry sequence.

To interrogate the Batch Preset value, Press "+/-" if necessary, until the Batch Count value is on the display (B annunciator is lit);

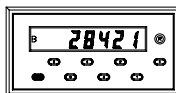

Press "1":
Unit displays the current Batch Preset value.

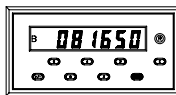

To change the Batch Preset value:
Any digit may be changed by pressing the pushbutton directly below it. Release the pushbutton when the digit reaches the desired value.

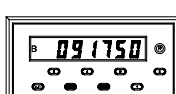

Press "E" to enter new Batch Preset value:
The GEMINI 3300 will then return to displaying the count value.

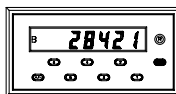

TYPICAL BATCH COUNTER APPLICATIONS

FORMS PACKAGING WITH COMMUNICATIONS

The system depicted below is an excellent example of the communications capability of the GEMINI 3300. The GEMINI is being employed to update an existing Process, in order to add indication, control, and monitoring of the machinery. The machine in question prints and packs business forms. The requirement exists for a control output when a specific number of forms are packaged. Another control output is needed when a specified number of packets have been manufactured. It is necessary to be able to change the two quantities via the central control system. The GEMINI's Process Counter counts input pulses from the form counting photo sensor. When Preset 2 is reached, Relay 2 and Solid-state Output 2 activate. The Form C relay contacts are used to signal the packaging mechanism that the desired number of forms have been accumulated. The GEMINI's Batch Count output is used in the same manner to stop the entire process when the desired amount of packages being produced in the line have been completed. The number of forms in each packet and the number of packets produced seldom remain the same for two consecutive runs. The capability to load the desired process and Batch presets remotely by an external control system is made possible by the optional 20 mA current loop of the GEMINI. The communications allow for remote monitoring and control of the GEMINI count and presets. Both of these factors account for a much improved production capability for this process.

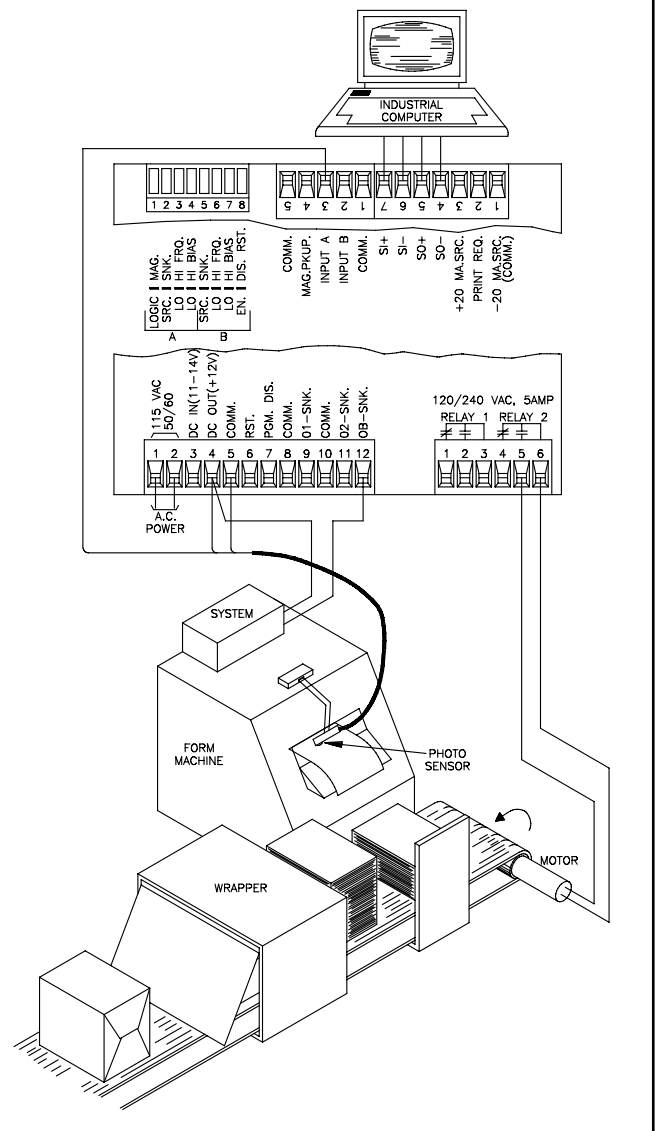

TYPICAL BATCH COUNTER APPLICATIONS (Cont'd)

CANDY BAR PACKAGING SYSTEM

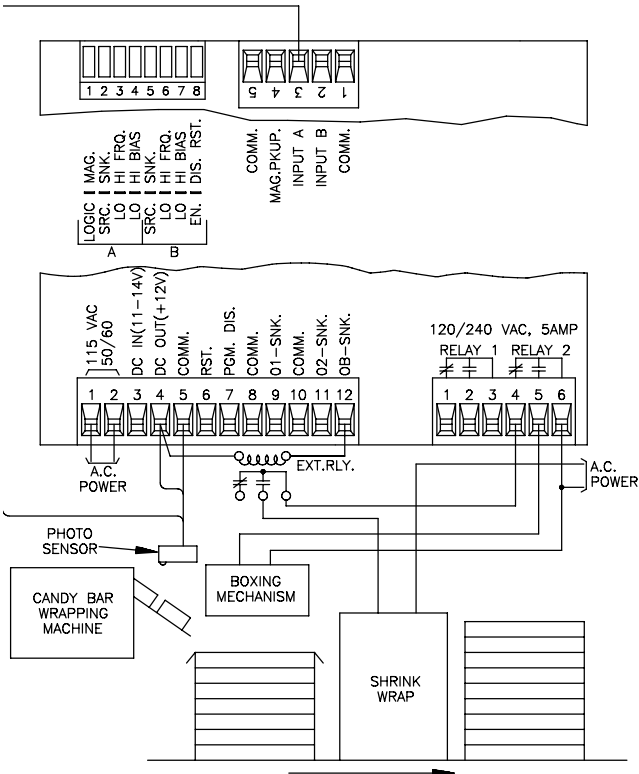

A typical batching application, shown above, requires two separate control functions. The first counts the production items in process (*candy bars*) and then provides a relay control output to the sealing mechanism (*when 24 candy bars are to be sealed in a distribution box and placed on a stack*). The Batch Counter of the GEMINI 3300 advances each time a distribution box is sealed. Another packaging mechanism is required to activate when 10 distribution boxes are stacked, ready to be shrink-wrapped with clear plastic. Both the Process and Batch Counters are programmed to reset and Run at the two preset numbers. For the shrink-wrap mechanism system to operate properly, it must not activate until the Process relay deactivates after the 24th bar of the 10th box. To achieve this, the power is fed to the Process Relay 2 common and the normally closed contact is connected to the common of the Batch Relay. When the process Output 2 fires, it disconnects power to the Batch relay which fires simultaneously with the Process Relay at the end of a batch. The batch timed output must be equal to the amount of time required for the shrink-wrap process plus the time required for the Process Output 2. The Process Output 2 energizes for 0.50 seconds and the required shrink-wrap process time is 4 seconds, so the batch timed output required is 4.50 seconds. The times are easily programmed via the front panel. The GEMINI 3300 allows the operator to maintain a watch on the Process, Batch, or Total Counts by simply pressing the "+/-" button to sequence the display to the desired count.

LENGTH PROCESSING UTILIZING SCALE FACTOR

Many times in web type processes it is necessary to scale the input to reflect the desired engineering units. In this application, a plastic bag webbing process is being measured with a 10 pulse LSC sensor (*length sensor and one foot circumference wheel*). The output of the LSC is the input to the GEMINI 3300. The requirements are for a readout and control in 10ths of yards. Thus for every additional yard, the display must increment by 10 counts. A decimal point in the 10ths position will be programmed to provide the desired display of 1.0 for each yard the process advances. In order to scale the existing input of 30 pulses per yard to the desired display reading of 10 (without decimal point), the scale multiplier is programmed as 0.1 and the scale factor is programmed to 3.3333. After this has been accomplished, the process control Output 2 is programmed to energize every 40.5 yards to cut the web in proper lengths. Ten yards before cut, process control Output 1 is to activate to provide a slow-down output. The Batch counter, which advances 1 count for each cut, can be set to stop the entire process at a desired production run limit. In this system, the production records require total yards produced every 24 hours regardless of the particular run in progress. The totalizing counter of the GEMINI 3300 solves the requirement. The unit can be programmed so that the Reset Button resets only the Process and Batch Counters and not the Total Count. This would prevent reset of the Total Count when setting up for each new production run. The daily tally of the total can be accomplished by a manual reading. To reset the total count, a count value of zero can be loaded into the Total Counter (*using "Counter Load Value"*), or a reset command can be issued if using the serial communication capability of the GEMINI 3300.

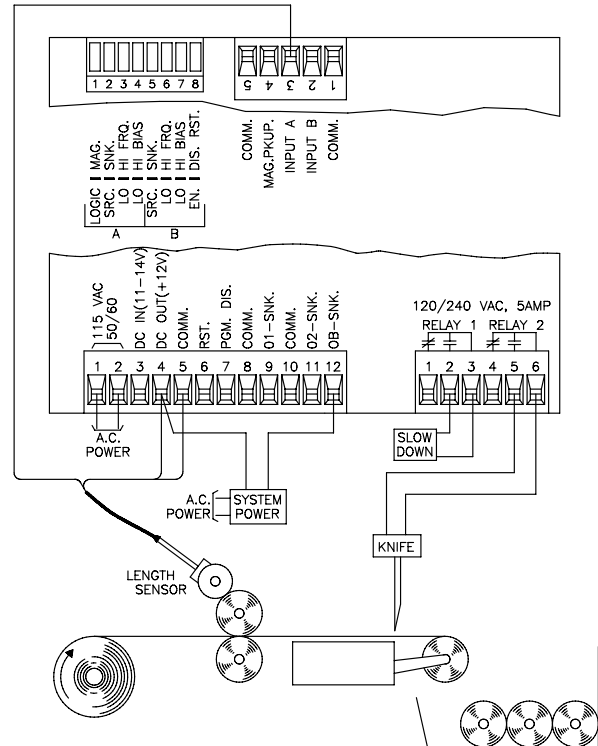

ORDERING INFORMATION

| MODEL NO. | DESCRIPTION | W/20 mA CURRENT LOOP | PART NUMBERS |
|-----------|------------------------------|-------------------------|--------------|
| | | | 115/230 VAC |
| GEM33 | Gemini 3300 | No | GEM33060 |
| | | Yes | GEM33160 |
| - | Gemini 2000/3300 Relay Board | N/A | RLYBD002 |

For more information on Pricing, Enclosures, & Panel Mount Kits, refer to the RLC Catalog or contact your local RLC distributor.

GEMINI 3300 BATCH COUNTER PROGRAMMING CHART

FEATURE & MODE SELECTION (See Programming Procedure)

DETAILED MODE MENUS

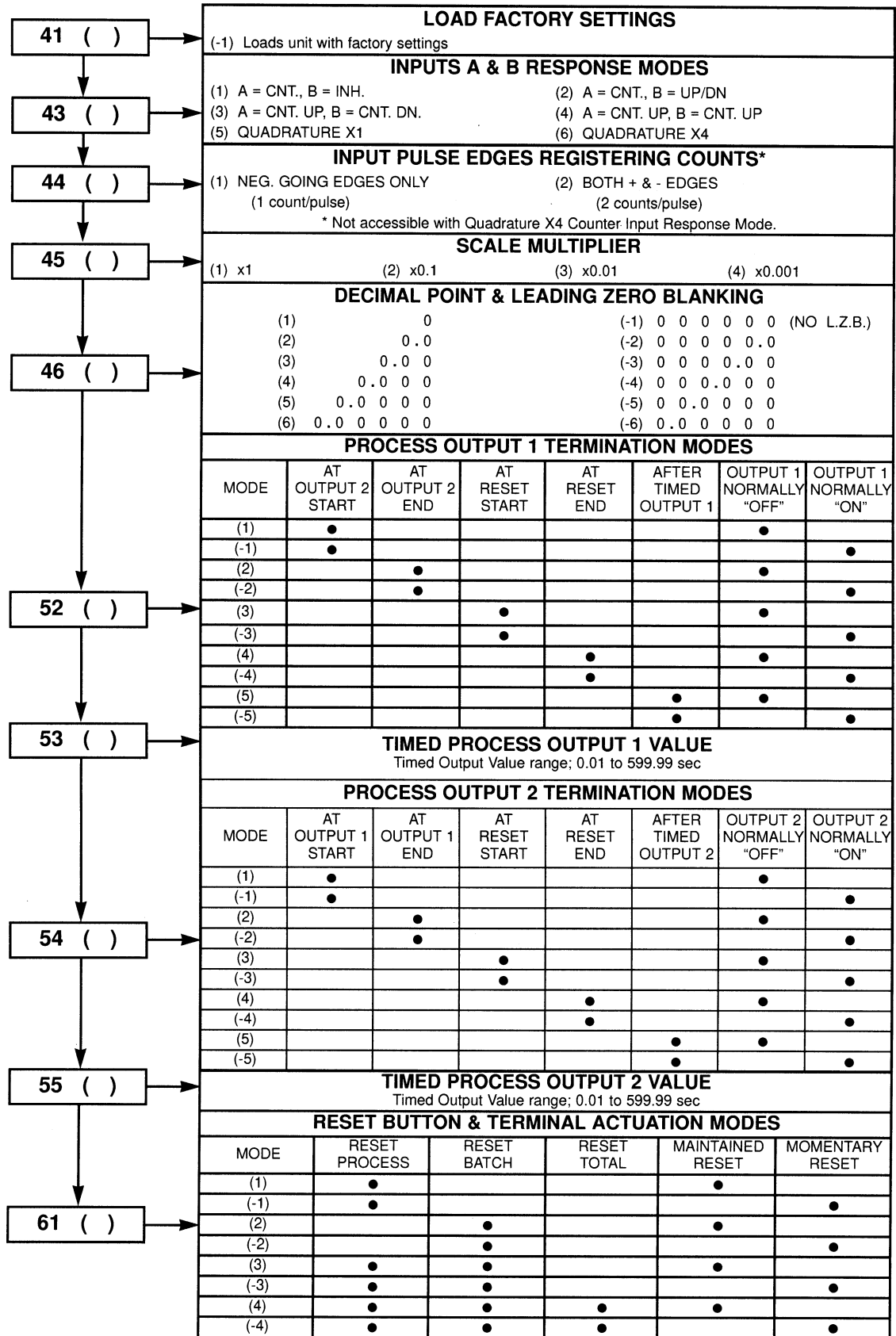

| PROCESS COUNTER RESET MODES | | | | | | |
|--|----------------|--------------------|--------------------------------|-----------------------------|--------------------------|-------------------------|
| MODE | RESET TO ZERO | RESET TO P.PRST 2 | AUTO RST AFTER TIMED OUT.2 | AUTO RST AT TIMED OUT.2 | PRESET TRACKING DISABLED | PRESET TRACKING ENABLED |
| (1) | • | | | | • | |
| (-1) | • | | | | | • |
| (2) | | • | | | • | |
| (-2) | | • | | | | • |
| (3) | • | | • | | • | |
| (-3) | • | | • | | | • |
| (4) | | • | • | | • | |
| (-4) | | • | • | | | • |
| (5) | • | | | • | • | |
| (-5) | • | | | • | | • |
| (6) | | • | | • | • | |
| (-6) | | • | | • | | • |
| BATCH COUNTER RESET MODES | | | | | | |
| MODE | RESET TO ZERO | RESET TO PRESET B. | AUTO RESET AFTER TIMED OUT. B. | AUTO RESET AT TIMED OUT. B. | | |
| (1) | • | | | | | |
| (2) | | • | | | | |
| (3) | • | | • | | | |
| (4) | | • | • | | | |
| (5) | • | | | | | • |
| (6) | | • | | | | • |
| BATCH OUTPUT TERMINATION MODES | | | | | | |
| MODE | AT RESET START | AT RESET END | AFTER TIMED OUTPUT B | OB-SNK NORMALLY "OFF" | OB-SNK NORMALLY "ON" | |
| (3) | • | | | • | | |
| (-3) | • | | | | • | |
| (4) | | • | | • | | |
| (-4) | | • | | | • | |
| (5) | | | • | • | | |
| (-5) | | | • | | • | |
| TIMED BATCH OUTPUT VALUE | | | | | | |
| Timed Output Value range; 0.01 to 599.99 sec | | | | | | |
| "OPERATOR ACCESSIBLE FUNCTIONS" MODES | | | | | | |
| (With "PGM. DIS." terminal to "COMM") | | | | | | |
| MODE | PRESET VALUES | SCALE FACTOR | COUNTER LOAD VALUES | 2-BUTTON RESET | RESET BUTTON & TERMINAL | |
| (1) | | | | | • | |
| (-1) | | | | | | • |
| (2) | • | | | | | • |
| (-2) | • | | | | | |
| (3) | | • | | | | • |
| (-3) | | • | | | | |
| (4) | • | • | | | | • |
| (-4) | • | • | | | | |
| (5) | • | | • | • | | • |
| (-5) | • | | • | • | | |
| (6) | • | • | • | • | | • |
| (-6) | • | • | • | • | | |

62 ()

63 ()

64 ()

65 ()

66 ()

GEMINI 3300 PROGRAMMING

SOME NOTES & HINTS ON PROGRAMMING THE GEMINI 3300

1. Be systematic about programming! Plan out the exact features & functions you need for your application. Write out the code entries you need from start to finish, and then enter the codes completely. Don't start in the middle of the program codes & make arbitrary entries to "see what it will do." This is a sure way to create confusing results. Finally, after you are done, record your program & file it where you can find it later if you want to make changes. You can use this card to write in your codes in the program ladder on the reverse side, together with any fixed data entries, for convenient future reference.

2. Watch out for conflicting modes! The programs in the GEMINI 3300 have been written to prevent illegal code entry.

However, to provide optimum flexibility, some reliance must be placed on the programmer to avoid conflicting codes.

3. The GEMINI 3300 can be interrogated at any time to see what modes & data entries have been made. Such interrogation can be made during a counting cycle or a sample time run without interrupting the normal counting process. In the lockout mode, all functions can also be interrogated, but those functions locked out cannot be changed. Making changes in program modes or data during a run is not recommended since mid-cycle changes can result in unanticipated outputs for that particular cycle.

PROGRAMMING PROCEDURE FOR FUNCTION & MODE SELECTION ☆ (Applies To Programming Chart)

To enter a programmable function or mode, enter the function selector code desired and then select the particular mode identifier required.

For example, to set up a decimal point to display a reading in 1/100ths with leading zero blanking, function selector code #46 must be entered. (See codes on reverse side.)

Press button #4, then button #6. The display will temporarily interrupt its normal readout (without interfering with the normal operation of the unit).

It will then display the entered code on the L.H. side.

[46] (DISPLAY READOUT)

Next, enter the mode identifier (button #3) that defines the decimal point location & LZB condition. This code is displayed on the right.

[46 3] (DISPLAY READOUT)

Now, enter this new selection by pressing the "E" button.

PROGRAMMING PROCEDURE FOR DATA ENTRY

In data entry, the front panel pushbuttons are identified by two different sets of references and will cause two different reactions in the course of making a data entry.

In the first phase of a data entry cycle, the particular data entry mode is called up by pushing the buttons identified by their panel markings. (i.e. Buttons "5", "3", or "1"). Once the data entry mode has been entered, the existing data appears on the display and the buttons below the display reference themselves to the digits directly above each button. The data can then be changed a digit at a time by depressing the button directly below the digits to be changed.

After the new data value is obtained, the "E" button is depressed to enter the new value.

[53, 55, 65] TIMED OUTPUT VALUES ☆

Entering Code "53, 55, or 65" will call up the Timed Output 1, 2, or B Value in seconds & hundredths. The value can be set to the new value by incrementing each digit with the button underneath that digit.

Press the "E" button to enter the new Timed Output value. (Max. Timed Output value = 599.99 sec.)

[3] SCALE FACTOR

One stroke of the "3" button calls up the current Scale Factor. (The Scale Factor is the multiplier used to convert the actual count to the direct readout display). The value can be changed by incrementing each digit with the button below it. Pressing the "E" key enters the new S.F. The S.F. can be set at any value from 0.0001 to 5.9999.

[1, 2] PRESETS

With the Process Count on the display, pressing the "1" or "2" button calls up the preset 1 or 2 value. With the Batch count on the display, pressing the "1" value calls up the Batch Preset value. They can then be changed by incrementing each digit with the button below it. Press the "E" button to enter the new Preset.

☆ Program before connecting "PGM. DIS." to "COMMON".

SELF TEST ROUTINE 6, +/-

Depressing "6" & then "+/-" starts the self test routine by lighting all decimal points, then all 9's, all 8's, all 7's etc., until alternate 8's & 9's are displayed. At this time, the output can be manually activated for testing by pressing the "1" or "2" button (Process only). (The

Output test is disabled when "PGM. DIS." terminal is pulled to "COMMON".) An automatic exit will occur six (6) seconds after the Test Mode is completed. Test Mode can be run at any time and will not interfere with the normal operation of the Gemini 3300.

LIMITED WARRANTY

The Company warrants the products it manufactures against defects in materials and workmanship for a period limited to one year from the date of shipment, provided the products have been stored, handled, installed, and used under proper conditions. The Company's liability under this limited warranty shall extend only to the repair or replacement of a defective product, at The Company's option. The Company disclaims all liability for any affirmation, promise or representation with respect to the products.

The customer agrees to hold Red Lion Controls harmless from, defend, and indemnify RLC against damages, claims, and expenses arising out of subsequent sales of RLC products or products containing components manufactured by RLC and based upon personal injuries, deaths, property damage, lost profits, and other matters which Buyer, its employees, or sub-contractors are or may be to any extent liable, including without limitation penalties imposed by the Consumer Product Safety Act (P.L. 92-573) and liability imposed upon any person pursuant to the Magnuson-Moss Warranty Act (P.L. 93-637), as now in effect or as amended hereafter.

No warranties expressed or implied are created with respect to The Company's products except those expressly contained herein. The Customer acknowledges the disclaimers and limitations contained herein and relies on no other warranties or affirmations.

Red Lion Controls
20 Willow Springs Circle
York PA 17402
Tel +1 (717) 767-6511
Fax +1 (717) 764-0839

Red Lion Controls BV
Basicweg 11b
NL - 3821 BR Amersfoort
Tel +31 (0) 334 723 225
Fax +31 (0) 334 893 793

Red Lion Controls AP
31, Kaki Bukit Road 3,
#06-04/05 TechLink
Singapore 417818
Tel +65 6744-6613
Fax +65 6743-3360