

MODEL PAXLCL - PAX LITE CURRENT LOOP METER



- DUAL RANGE, 4 to 20 mA or 10 to 50 mA *
- 3 1/2-DIGIT, 0.56" (14.2 mm) HIGH LED READOUT
- 24 VDC EXCITATION SUPPLY
- WIDE SPAN & OFFSET SCALING RANGE
- OVER-RANGE INDICATION
- SELECTABLE DECIMAL POINTS
- NEMA 4X/IP65 SEALED FRONT BEZEL
- OPTIONAL CUSTOM UNITS OVERLAY W/BACKLIGHT

* Also adapts to 0 to 50, 0 to 20, 0 to 10, 1 to 5 mA ranges as well as bi-polar inputs.



GENERAL DESCRIPTION

The premium features of the PAX Lite Series can now be applied to measurement of process variables. With its high sensitivity and programmability, the PAX Lite Current Loop Meter can be set up for a wide variety of applications. In most plants the PAXLCL can be used for 90 to 95% of current loop meter needs for readout of pressure, flow, temperature, level and other variables. The meter has been specifically designed for harsh industrial environments. With NEMA 4X/IP65 sealed bezel and extensive testing of noise effects to CE requirements, the meter provides a tough yet reliable application solution. This allows the PAXLCL to be used in dirty, hostile environments and in wash-down areas. The 3 1/2-digit bi-polar display (minus sign displayed when current or voltage is negative) features 0.56" (14.2 mm) high, 7-segment LEDs for easy reading.

SAFETY SUMMARY

All safety related regulations, local codes and instructions that appear in the literature or on equipment must be observed to ensure personal safety and to prevent damage to either the instrument or equipment connected to it. If equipment is used in a manner not specified by the manufacturer, the protection provided by the equipment may be impaired.



DIMENSIONS In inches (mm)

Note: Recommended minimum clearance (behind the panel) for mounting clip installation is 2.1" (53.4) H x 5.0" (127) W.

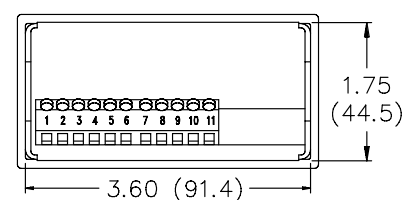
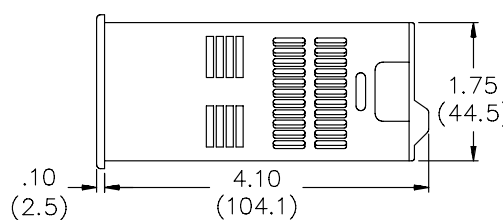
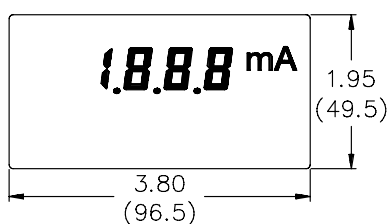
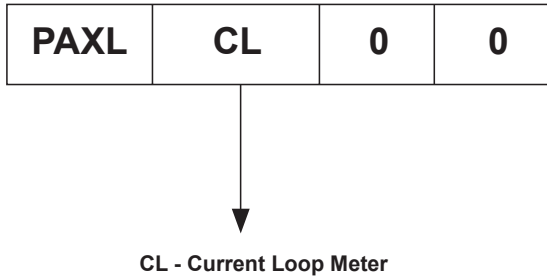

TABLE OF CONTENTS

Ordering Information	2	Wiring the Meter	4
General Meter Specifications	3	Scaling the Meter	6
Accessories	3	Calibrating the Meter.	7
Installing the Meter	4	Applications	8
Setting the Switches	4		

ORDERING INFORMATION

Meter Part Numbers



Accessories Part Numbers

TYPE	MODEL NO.	DESCRIPTION	PART NUMBERS
Accessories	PAXLBK	Units Label Kit Accessory	PAXLBK30

GENERAL METER SPECIFICATIONS

- DISPLAY:** 3 1/2-digit, 0.56" (14.2 mm) high, 7-segment LED, (-) minus sign displayed when current or voltage is negative. Decimal points inserted before 1st, 2nd, or 3rd least significant digits by DIP switch selection.
- OVER-RANGE INDICATION:** Indicated by blanking 3 least significant digits.
- POWER:**
 - AC Power:** 85 to 250 VAC, 50/60 HZ, 6 VA
 - Isolation:** 2300 Vrms for 1 min. between input and supply (300 V working voltage).
- INPUT SENSITIVITY:** (Numerical Readout Change/mA)
 - 260 units/mA @ 4 to 20 mA input
 - 105 units/mA @ 10 to 50 mA input
 - (max. allowable input current, 170 mA)
- COMPLIANCE:** Voltage drop across input at max. signal current, less than 600 mV for both 4 to 20 and 10 to 50 mA ranges.
- INPUT RESISTANCE:**
 - 4 to 20 mA** - 29.2 Ω
 - 10 to 50 mA** - 11.8 Ω
- SCALING RANGE:**
 - SPAN:** 32 coarse steps (binary progression with 5 DIP switches) Each step providing approx. 8.125 numerical units/mA/step sensitivity for 4 to 20 mA input and 3.25 units/mA/step for 10 to 50 mA input.
 - OFFSET:** 16 coarse steps (binary progression with 4 DIP switches) with \pm switch to add or subtract offset. Each step adds or subtracts approximately 175 from the numerical display for a total offset range of ± 2700 .
- LINEARITY:** $\pm(0.05\% \pm 1 \text{ digit})$
- READING RATE:** 2.5 updated readings/second, nominal.
- RESPONSE TIME:** 1 second to settle for step change.
- LOW FREQUENCY NOISE REJECTION:**
 - Normal Mode Rejection:** 63 dB @ 50/60 Hz
 - Common Mode Rejection:** 100 dB, DC to 50/60 Hz
- ENVIRONMENTAL CONDITIONS:**
 - Operating Temperature:** 0° to 60°C
 - Storage Temperature:** -40° to 80°C
 - Operating and Storage Humidity:** 85% max. relative humidity (non-condensing)
 - Span Temperature Coeff.:** 100 PPM/°C
 - Offset Temperature Coeff.:** 100 PPM/°C
 - Altitude:** Up to 2000 meters
- CERTIFICATIONS AND COMPLIANCES:**
 - SAFETY**
 - UL Recognized Component, File # E179259, UL3101-1, CSA C22.2 No. 1010-1
 - Recognized to U.S. and Canadian requirements under the Component Recognition Program of Underwriters Laboratories, Inc.
 - UL Listed, File # E137808, UL508, CSA C22.2 No. 14-M95
 - LISTED by Und. Lab. Inc. to U.S. and Canadian safety standards
 - Type 4X Enclosure rating (Face only), UL50
 - IECEE CB Scheme Test Certificate # UL/7470A/UL
 - CB Scheme Test Report # 03ME09282-08292003
 - Issued by Underwriters Laboratories, Inc.
 - IEC 1010-1, EN 61010-1: Safety requirements for electrical equipment for measurement, control, and laboratory use, Part 1.
 - IP65 Enclosure rating (Face only), IEC 529
 - IP20 Enclosure rating (Rear of unit), IEC 529

ELECTROMAGNETIC COMPATIBILITY

Emissions and Immunity to EN 61326: Electrical Equipment for Measurement, Control and Laboratory use.

Immunity:

Electrostatic discharge	EN 61000-4-2	Criterion A 4 kV contact discharge 8 kV air discharge
Electromagnetic RF fields	EN 61000-4-3	Criterion B 10 V/m
Fast transients (burst)	EN 61000-4-4	Criterion A 2 kV power 2 kV signal
Surge	EN 61000-4-5	Criterion A 1 kV L-L, 2 kV L&N-E power 1 kV signal
RF conducted interference	EN 61000-4-6	Criterion A 3 V/rms
Power frequency magnetic fields	EN 61000-4-8	Criterion A 30 A/m
Voltage dip/interruptions	EN 61000-4-11	Criterion A 0.5 cycle

Emissions:

Emissions	EN 55011	Class B
-----------	----------	---------

Notes:

1. Criterion A: Normal operation within specified limits.
2. Criterion B: Temporary loss of performance from which the unit self-recovers.

14. **EXCITATION SUPPLY:** 24 VDC @ 50 mA max. Regulated and isolated.
15. **CONNECTIONS:** High compression cage-clamp terminal block
 - Wire Strip Length: 0.3" (7.5 mm)
 - Wire Gauge: 30-14 AWG copper wire
 - Torque: 4.5 inch-lbs (0.51 N-m) max.
16. **CONSTRUCTION:** This unit is rated for NEMA 4X/IP65 use. IP20 Touch safe. Installation Category II, Pollution Degree 2. One piece bezel/case. Flame resistant. Panel gasket and mounting clip included.
17. **WEIGHT:** 0.65 lbs (0.24 kg)

ACCESSORIES

UNITS LABEL KIT (PAXLBK)

Each meter has a units indicator with backlighting that can be customized using the Units Label Kit (PAXLBK30). The backlight is controlled by a DIP switch.

1.0 INSTALLING THE METER

Installation

The PAX meets NEMA 4X/IP65 requirements when properly installed. The unit is intended to be mounted into an enclosed panel. Prepare the panel cutout to the dimensions shown. Remove the panel latch from the unit. Slide the panel gasket over the rear of the unit to the back of the bezel. The unit should be installed fully assembled. Insert the unit into the panel cutout.

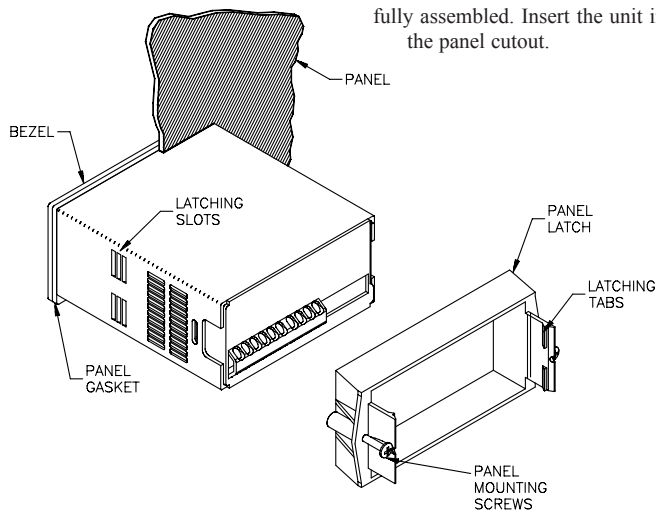

While holding the unit in place, push the panel latch over the rear of the unit so that the tabs of the panel latch engage in the slots on the case. The panel latch should be engaged in the farthest forward slot possible. To achieve a proper seal, tighten the latch screws evenly until the unit is snug in the panel (Torque to approximately 7 in-lbs [79N-cm]). Do not over-tighten the screws.

Installation Environment

The unit should be installed in a location that does not exceed the maximum operating temperature and provides good air circulation. Placing the unit near devices that generate excessive heat should be avoided.

The bezel should be cleaned only with a soft cloth and neutral soap product. Do NOT use solvents. Continuous exposure to direct sunlight may accelerate the aging process of the bezel.

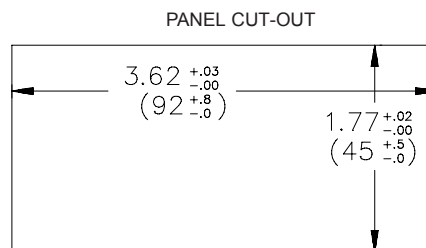

2.0 SETTING THE SWITCHES

The meter has switches, which must be checked and/or changed prior to applying power. To access the switches, remove the meter base from the case by firmly squeezing and pulling back on the side rear finger tabs. This should lower the latch below the case slot (which is located just in front of the finger tabs). It is recommended to release the latch on one side, then start the other side latch.

Set-Up DIP Switches

Two banks of DIP switches are located inside the meter. The 10 position bank of switches are used for calibrating the meter. The values of these switches are discussed in section 5.0 Calibrating the Meter.

The bank of 4 switches located near the front display are used for the selection of decimal points and backlight annunciator. Selecting "ON" position enables the function.

SWITCH	FUNCTION
1	Decimal Point 1 (000.0)
2	Decimal Point 2 (00.00)
3	Decimal Point 3 (0.000)
4	Backlight Annunciator for Units Label

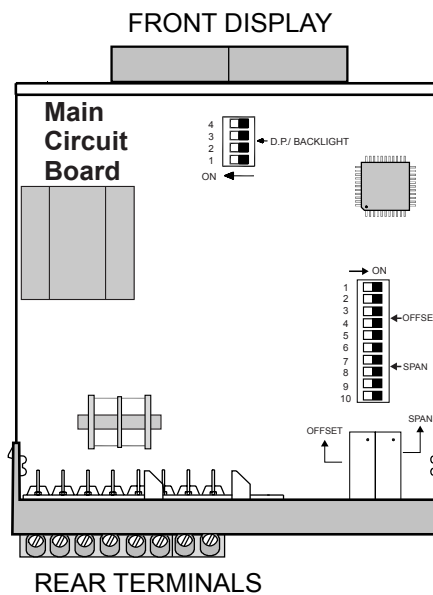

3.0 WIRING THE METER

WIRING OVERVIEW

Electrical connections are made via screw-clamp terminals located on the back of the meter. All conductors should conform to the meter's voltage and current ratings. All cabling should conform to appropriate standards of good installation, local codes and regulations. It is recommended that power supplied to the meter (AC) be protected by a fuse or circuit breaker.

When wiring the meter, compare the numbers embossed on the back of the meter case against those shown in wiring drawings for proper wire position. Strip the wire, leaving approximately 0.3" (7.5 mm) bare lead exposed (stranded wire should be tinned with solder). Insert the lead under the correct screw-clamp terminal and tighten until the wire is secure. (Pull wire to verify tightness.)

EMC INSTALLATION GUIDELINES

Although this meter is designed with a high degree of immunity to Electro-Magnetic Interference (EMI), proper installation and wiring methods must be followed to ensure compatibility in each application. The type of the electrical noise, its source or the method of coupling into the unit may be different for various installations. Listed below are some EMC guidelines for successful installation in an industrial environment.

1. The meter should be mounted in a metal enclosure, which is properly connected to protective earth.
2. Never run Signal or Control cables in the same conduit or raceway with AC power lines, conductors feeding motors, solenoids, SCR controls, and heaters, etc. The cables should be run in metal conduit that is properly grounded. This is especially useful in applications where cable runs are long and portable two-way radios are used in close proximity or if the installation is near a commercial radio transmitter.
3. Signal or Control cables within an enclosure should be routed as far away as possible from contactors, control relays, transformers, and other noisy components.
4. In extremely high EMI environments, the use of external EMI suppression devices, such as ferrite suppression cores, is effective. Install them on Signal and Control cables as close to the unit as possible. Loop the cable through the core several times or use multiple cores on each cable for additional protection.

Install line filters on the power input cable to the unit to suppress power line interference. Install them near the power entry point of the enclosure. The following EMI suppression devices (or equivalent) are recommended:

Ferrite Suppression Cores for signal and control cables:

Fair-Rite # 0443167251 (RLC #FCOR0000)

TDK # ZCAT3035-1330A

Steward #28B2029-0A0

Line Filters for input power cables:

Schaffner # FN610-1/07 (RLC #LFIL0000)

Schaffner # FN670-1.8/07

Corcom #1VR3

Note: Reference manufacturer's instructions when installing a line filter.

5. Long cable runs are more susceptible to EMI pickup than short cable runs. Therefore, keep cable runs as short as possible.

6. Switching of inductive loads produces high EMI. Use of snubbers across inductive loads suppresses EMI.

Snubber: RLC#SNUB0000.

3.1 POWER WIRING

AC Power

Terminal 1: VAC

Terminal 2: VAC

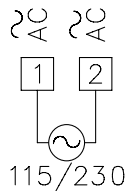

3.2 INPUT SIGNAL WIRING

2-WIRE, EXTERNAL EXCITATION

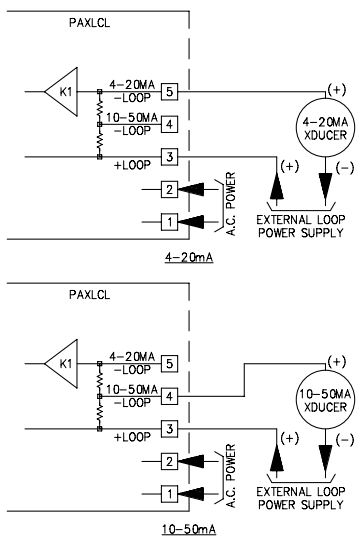

2-WIRE, WITH EXCITATION (Series Conn.)

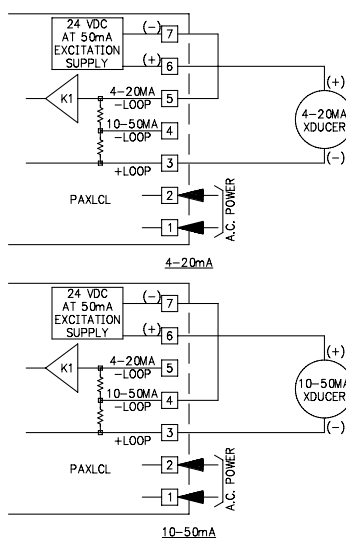

2-WIRE, WITH EXCITATION (Parallel Conn.)

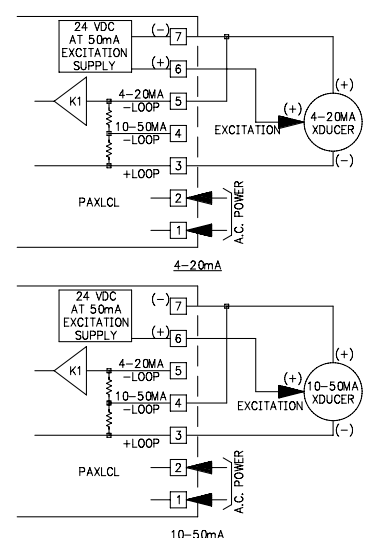

NOTES

1. When shielded wire leads are used, connect the shield to earth ground at the meter and insulate the other end to avoid contact with machine ground.
2. Never run signal leads in conduit, bundles, or race ways with power conductors. Avoid runs close to contactors, relays, solenoids, transformers, and other potential sources of electrical noise.

4.0 SCALING THE METER

PAXLCL SCHEMATIC

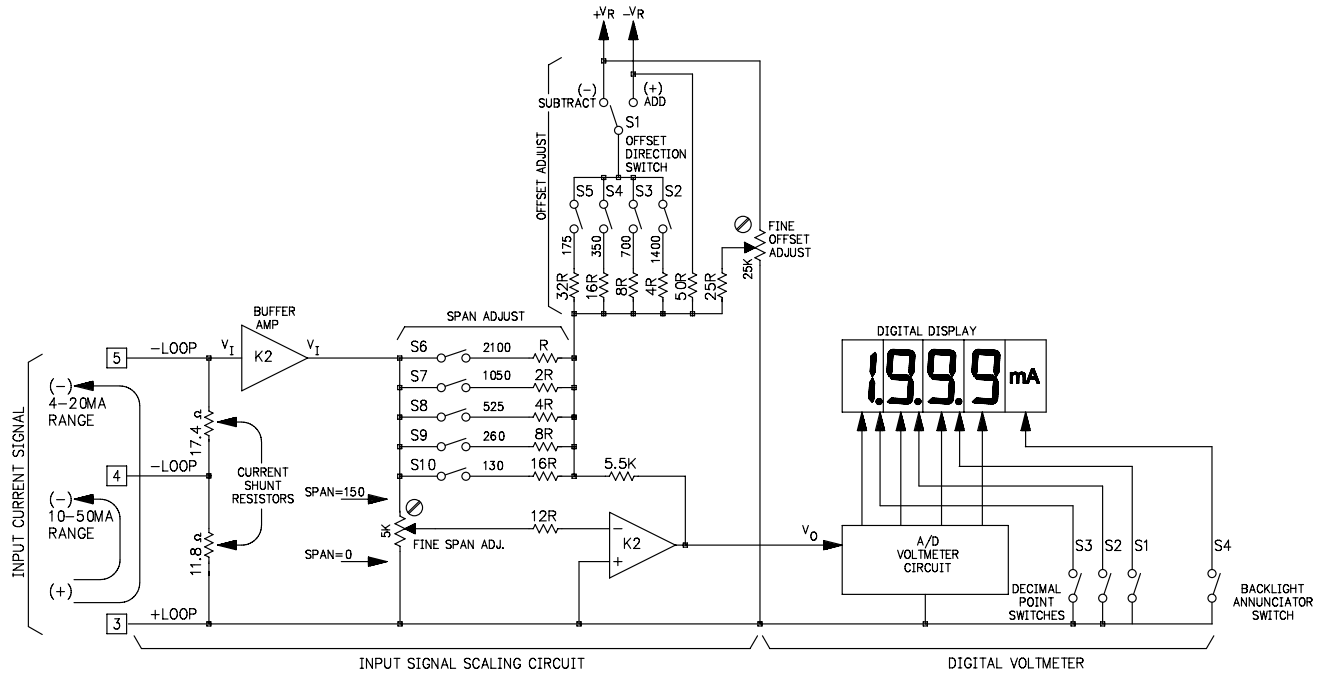

DESCRIPTION OF OPERATION

The PAX Lite Current Loop Meter consists of a digital volt meter combined with an analog scaling circuit (shown above). The unit was designed primarily for use with 4-20 mA and 10-50 mA current loop signal circuits. However, it can also be adapted to other current ranges, such as 0-50 mA, 0-20 mA, 0-10 mA, and in a great many applications it can be used even with 0-5 mA and 1-5 mA current loops. In addition, input current can be reversed in polarity resulting in negative numerical readout with a minus (-) sign displayed. Input terminals 3 and 4 are connected in series with 10-50 mA current loops, and Terminal 3 and 5 are series connected with 4-20 mA loops. In either case, the voltage drop generated across the shunt resistor(s) ranges from approximately 0.12 V min. (@ 4 or 10 mA) to 0.59 V max. (@ 20 or 50 mA). The buffer amplifier (K1) conditions and filters the input signal voltage and applies it to the input of the scaling circuit. The procedure for scaling PAX Lite Current Loop Meters is simplified by dividing the scaling process into two separate components, span adjustments and offset adjustments which are defined in the following discussion.

SPAN ADJUSTMENTS

Span is defined as the numerical range that the display traverses, disregarding decimal points, when the input signal current is varied from minimum (4 or 10 mA) to maximum (20 or 50 mA). For example, if a unit is to display 25.0 @ 4 mA and 100.0 @ 20 mA, the span is 750 (the difference between 250 and 1000). Had the minimum display been -25.0 @ 4 mA and +100.0 @ 20 mA, the span would be 1250 (1000 - (-250) = 1250). (Note: the terms "GAIN", "SCALE", and "SENSITIVITY" are also frequently used interchangeably with the term "SPAN.") The PAX Lite Current Loop Meter can be set up over a very wide span range by means of the coarse DIP switches S6-S10, and the fine screwdriver adjustment pot, located at the back cover. The coarse span switches add parallel input resistors to the summing amplifier (K2), thereby increasing its gain, or sensitivity, as more summing resistors are added. Effectively, adding more parallel input resistors, increases the slope of the transfer curve (at right) and increases the numerical readout for a given input signal current change. The input summing resistor values are weighted in a binary progression, so they can be switched in combinations to give 32 discrete steps of span. The fine adjust control brackets these coarse steps and can be adjusted to the exact span needed.

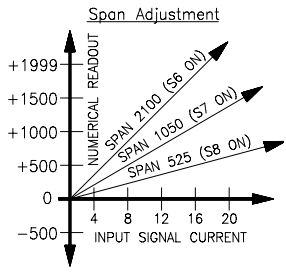

The approximate span contributed by each switch is shown on the rear label. These values are based on the standard current-loop spans of 4 to 20 mA (16 mA current variation) and 10-50 mA (40 mA current variation). In other words, if S7 only is turned "ON", the numerical readout will display a change approximately 1050 for a current swing of 16 mA (4-20 mA input) or 40 mA (10-50 mA input). If S8 were also turned "ON", the numerical readout would swing approximately 1575 (1050 for S7 + 525 for S8) for the same signal current variation. The fine control has a continuous span range of approximately 0-150.

OFFSET ADJUSTMENTS

In the foregoing discussion of span, the transfer curves were shown as "ZERO-BASED", i.e., the numerical readout displays "0" when the signal current goes to zero. With current loop ranges such as 0-5 or 0-10, or 0-20 mA, and with Bi-Polar (+/-) signals, this is often the desired condition. However, with 4-20 and 10-50 mA current loops, the minimum current level of 4 or 10 mA usually represents the zero level of the parameter being displayed. There are also many applications where the minimum (or zero level) represents some value that does not fall on a zero based transfer curve. To accommodate non-zero based applications, the PAX Lite Current Loop Meter has provisions for offsetting the transfer curve over a wide range. Essentially, offset moves the transfer curve up or down to change its intercept with the numerical readout axis, but it does not change the slope (SPAN) of the transfer curve. In the PAX Lite Current Loop Meter, offset is accomplished by adding (or subtracting) a constant at the input of the summing amplifier (K2). This offset constant is summed in with a switched binary resistor network and a fine adjust offset control in a similar manner to that used for span adjustment. Switches S2-S5 can be turned on in combinations to give 16 different coarse offset levels. Each switch is labeled to show the approximate amount of offset contributed when it is turned "ON". Switch 1 selects the polarity of the switched-in offset value and allows offsetting the transfer curve "UP" (adding the offset constant) or "DOWN" (subtracting). The fine offset control has a numerical readout range of ± 100 and brackets all the coarse switched ranges.

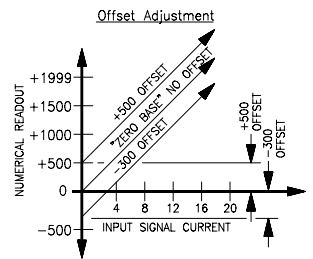

5.0 CALIBRATING THE METER

Direct calibration in the signal loop is usually not practical due to the difficulty in varying the measured parameter and the confusing interaction that occurs between span and offset adjustments. However, the PAXLCL can be quickly and easily bench calibrated using a commercially available current calibrator or the calibration set-up shown below.

CALIBRATION PROCEDURE

The procedure outlined below minimizes span/offset interaction and simplifies calibration. In Steps 1 to 4 the unit is “nulled” to zero readout with zero input signal current. In Steps 5 and 6, the span adjustments are made to establish the required slope of the transfer curve. Then in Step 7, the transfer curve is shifted up or down as required by setting the offset adjustments. In Step 8, the final “tweaking” adjustments are made at minimum and maximum signal current. Setting the decimal points in Step 9 completes the calibration.

Before calibrating, the READOUT SPAN (Rs) and SWING CURRENT (Is) must be determined.

WHERE:

$R_s = (\text{Max. Numerical Display}) - (\text{Min. Numerical Display})$ (Disregard Decimal Points)

$I_s = (\text{Current @ Max. Display}) - (\text{Current @ Min. Display})$

Example:

Readout is to be 0.00 @ 4 mA and 10.00 @ 20 mA.

READOUT SPAN (Rs) = 1000 - 0 = 1000

SWING CURRENT (Is) = 20 mA - 4 mA = 16

CALIBRATION STEPS

1. Power down the meter and remove it from its case. Turn off all offset and span adjustment switches (S2-S10 down). S1 has no effect when zeroing and can be in either position.
2. Turn the span control pot fully counter-clockwise (20 turns max.).
3. Turn on a combination of span adjust switches (6-10) to obtain a total value closest to (but not greater than) the READOUT SPAN (Rs) desired (1000 in this example). The following chart gives an approximate span adjustment value for each switch:

SWITCH NUMBER	SPAN VALUE
6	2100
7	1050
8	525
9	260
10	130

4. Place unit in its case and apply power. Apply zero current. Adjust the indicator to read zero using the offset adjustment pot.
5. Apply the SWING CURRENT (Is) (16 mA in the example) to the input. Set the exact READOUT SPAN value (1000) with span adj.pot.
6. Apply zero current to see if the zero value has shifted. If it has, re-zero with the offset pot, then repeat Step 5.
7. After the span has been adjusted, set the signal current to the minimum level (4 mA in the example). Record the meter reading (in this example the reading will be 250). Subtract the desired reading at minimum current value (0 in the example) from the recorded reading (0-250 = - 250). Power down the meter and remove it from its case. Set the offset add/subtract switch S1 (subtract = on), and the offset switches (S2-S5) to obtain a total value closest to (but no more than) the difference between the desired reading at minimum current value and the observed reading. The following chart gives an approximate offset adjustment value for each switch:

SWITCH NUMBER	OFFSET VALUE
2	1400
3	700
4	350
5	175

Place the meter in its case and apply power. Using the offset adjust pot, adjust the readout to equal the desired reading at the minimum current value (0 in the example).

8. Adjust the input signal current to its maximum value to see if the proper readout is obtained (1000 @ 20 mA in the example). If the readout is slightly off, adjust the span pot to obtain the true reading. Then, recheck the reading at the minimum input current (4 mA) and readjust the offset pot if necessary. Repeat the maximum and minimum readout adjustments until the unit displays the proper readout at both extremes.
9. Set decimal points as desired using the three decimal point switches. The unit can now be installed.

TROUBLESHOOTING

For further assistance, contact technical support at the appropriate company numbers listed.

LIMITED WARRANTY

The Company warrants the products it manufactures against defects in materials and workmanship for a period limited to one year from the date of shipment, provided the products have been stored, handled, installed, and used under proper conditions. The Company's liability under this limited warranty shall extend only to the repair or replacement of a defective product, at The Company's option. The Company disclaims all liability for any affirmation, promise or representation with respect to the products.

The customer agrees to hold Red Lion Controls harmless from, defend, and indemnify RLC against damages, claims, and expenses arising out of subsequent sales of RLC products or products containing components manufactured by RLC and based upon personal injuries, deaths, property damage, lost profits, and other matters which Buyer, its employees, or sub-contractors are or may be to any extent liable, including without limitation penalties imposed by the Consumer Product Safety Act (P.L. 92-573) and liability imposed upon any person pursuant to the Magnuson-Moss Warranty Act (P.L. 93-637), as now in effect or as amended hereafter.

No warranties expressed or implied are created with respect to The Company's products except those expressly contained herein. The Customer acknowledges the disclaimers and limitations contained herein and relies on no other warranties or affirmations.

6.0 APPLICATIONS

Example 1:

A PAXLCL is to be calibrated to match a flow transducer whose output is 10 mA @ 0 GPM and 50 mA @ 1375 GPM.

READOUT SPAN (Rs) = 1375 - 0 = 1375

SWING CURRENT (Is) = 50 mA - 10 mA = 40 mA

ADJUSTMENTS (Refer to the transfer curve below)

- Null the unit to zero readout @ 0 current per Steps 1 to 4 of the calibration steps.
- Set the coarse and fine span adjustments to get a readout of 1375 @ 40 mA per Steps 5 and 6. *Note: With the full standard swing of 40 mA, the coarse span switch reference markings can be used to determine settings as follows:
S7 ON (1050) + S9 ON (260) = 1310
Span set with switches.
375 (needed) - 1310 (with SW's) = 65 w. fine span adj.*
- Set offset to readout 0 @ 10 mA per Step 7. *Note: The read out observed when the 10 mA min. current is first applied can be used to determine the offset switch settings.)* In this example the readout will be (+) 344 when the 10 mA min. current is first applied. Applying -344 offset then reduces the readout to zero @ 10 mA.
- Check readout at max. (50 mA) and min. (10 mA) and fine tune (tweak) as required per Step 8.

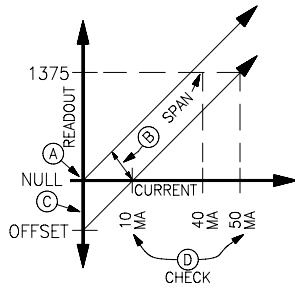

Example 2 (Negative Slope):

A level measuring device puts out 6 mA when a storage tank is full and 15 mA when the tank is empty. The PAXLCL is to readout 90.0 tons at full tank and zero when empty.

READOUT SPAN (Rs) = 900 - 0 = 900 (Disregard Decimal Points)

SWING CURRENT (Is) = 6 mA (@ max rdg) - 15 mA (@ min rdg) = -9 mA

In this case, the signal current is reverse [Term 3 (-) with respect to Term 5 (+)] causing the readout to go "down" (increasingly negative) as the negative current increases.

ADJUSTMENTS

- Null the unit per Steps 1 to 4.
- Set slope of transfer curve with span adjustments to get readout of -900 @ -9 mA per Steps 5 and 6.
- Move transfer curve up by applying (+) offset per Step 7 until readout is +900 @ -6 mA.
- Check extreme readings per Step 8, 0 readout @ -15 mA and +900 readout @ -6 mA. Set D.P. Switch S1 and replace unit in case.

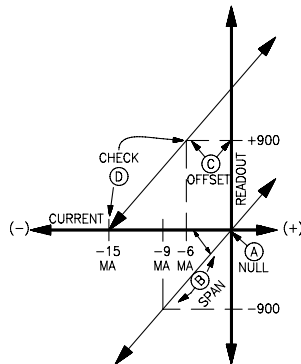

Example 3 (± Display):

A differential pressure transducer has a range of ±1500 PSI with a 4 to 20 mA output (-1500 @ 4 mA, +1500 @ 20 mA).

READOUT SPAN (Rs) = +1500 - (-1500) = 3000

SWING CURRENT (Is) = 20 mA(max) - 4 mA(min) = 16 mA

Note: Since the display readout is limited to 1999 numerical indication, the full READOUT SPAN of 3000 cannot be obtained during zero based span adjustment. However, dividing both the READOUT SPAN and SWING CURRENT by two, i.e. 1500 readout @ 8 mA, allows the span adjustment to be made for the proper transfer curve slope.

ADJUSTMENTS

- Null the unit per Steps 1 to 4.
- Set transfer curve slope with span adjustments per Steps 5 and 6, to get a readout of +1500 @ 8 mA.
- Apply (-) offset per Step 7 to get a reading of -1500 @ 4 mA.
- Check min. and max. extremes and tweak if required to get desired readout @ 4 and 20 mA per Step 8.

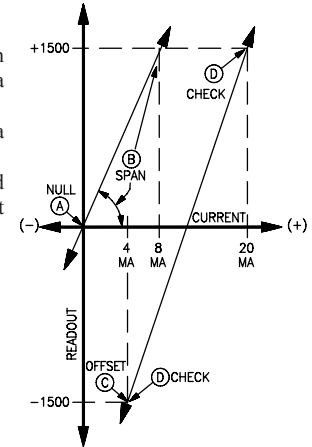

Red Lion Controls
20 Willow Springs Circle
York PA 17402
Tel +1 (717) 767-6511
Fax +1 (717) 764-0839

Red Lion Controls BV
Basicweg 11b
NL - 3821 BR Amersfoort
Tel +31 (0) 334 723 225
Fax +31 (0) 334 893 793

Red Lion Controls AP
31, Kaki Bukit Road 3,
#06-04/05 TechLink
Singapore 417818
Tel +65 6744-6613
Fax +65 6743-3360