

SERIES AZ415

Tamper-Resistant Movable Machine Guard Safety Interlock Switch



Features & Benefits

- **Highly tamper-resistant** ... difficult to defeat.
- **“Positive-break” NC contacts** ... assure circuit interruption upon key removal.
- **Watertight design** ... meets IP67 washdown requirements.
- **High-strength, metal actuator key** ... tolerates mechanical abuse without damage.
- **Rugged, enamel-coated metal housing** ... tolerates the most hostile environments.
- **Adjustable actuator key holding force up to 110 pounds** ... permits use of switch as door latch.
- **Meets rigid safety agency standards** ... UL, CSA, IEC, BG and VDE.

Description

The AZ415 Series is designed for movable machine guards/access gates which must be closed for operator safety. Their positive-opening NC contacts provide a significantly higher level of safety than conventional spring-driven switches whose contacts can weld or stick shut. And their tamper-resistant design prevents bypassing with simple tools, bent wires or other readily available means.

Operation

The AZ415 electromechanical safety interlock switch consists of a rugged switch mechanism and a geometrically-unique actuating key. The key is mounted to the movable guard. Upon opening of the guard, the NC contacts are forced to open through a direct (non-resilient) mechanical linkage with the actuating key. These NC contacts assure circuit interruption (and machine stoppage) upon removal of the actuator key. (The NO contacts close upon key removal.)

In the closed position, the guard is held shut by an adjustable ball catch integral to the AZ415 housing.

Typical Applications

The AZ415 is intended for use as a safety interlock switch on movable machine guards which, when open, expose the operator/maintenance personnel to machine hazards. Typical applications are the interlocking of protective gratings, access doors/gates, hinged covers, access panels and other movable guards.

AVAILABLE STANDARD MODELS (Actuator key sold separately ... see below)

Part Number (AZ415 - Switch Block S1*/ Switch Block S2)	Contact Configuration with actuator key inserted (Switch Block S1*/Switch Block S2)
AZ415-11/11zpk (formerly p/n AZ415-22zpk)	2 NO / 2 NC
AZ415-11/02zpk	1 NO & 1 NC / 2 NC
AZ415-02/11zpk	2 NC / 1 NO & 1 NC
AZ415-02/02zpk	2 NC / 2 NC

*Only Switch Block S1 has positive-break contacts.

ACTUATING KEYS & ACCESSORIES

Part Number	Description
AZM415-B1	Linear entry actuator key
AZM415-B2	Small radius x-axis entry actuator key (9.8" minimum closing radius)
AZM415-B3	Small radius y-radius entry actuator key (9.8" minimum closing radius)
AZ/AZM415-B4PS	Slide bolt actuator key

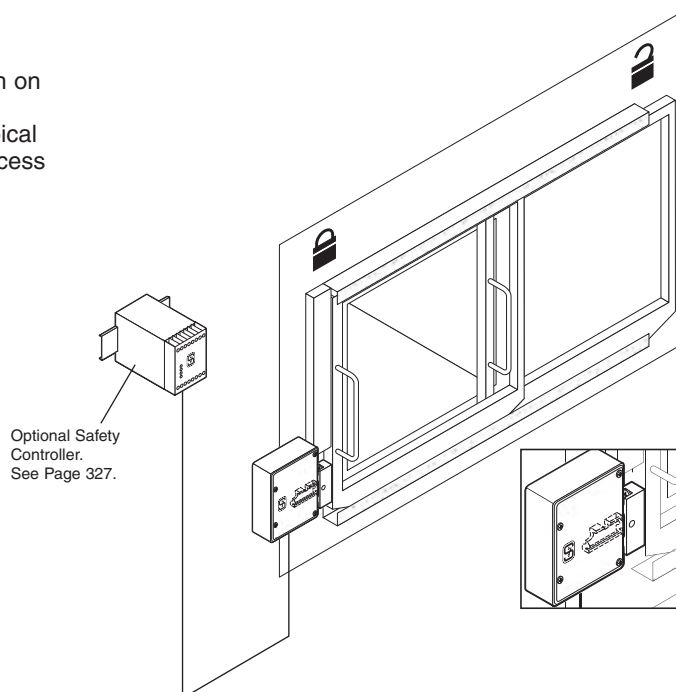

AZ415 TECHNICAL DATA

MECHANICAL SPECIFICATIONS

Housing	Die-cast aluminum with blue enamel finish
Actuator Key	Die-cast aluminum
Degree of Protection	IP67
Travel for Positive-Break	0.2 inches (5mm)
Force to Reach Positive-Break	Depending upon ball catch setting (3.5 pounds minimum)
Actuator Key Holding Force	Adjustable, 2.2 to 110 pounds
Operating Temperature	-13°F to +175°F
Mechanical Life	1 million operations
Conformity to Standards	IEC 947-5-1 BG-GS-ET-19 VDE 0660-200
Minimum Closing Radius	9.8" (250 mm) with B2 or B3 actuating key

ELECTRICAL SPECIFICATIONS

Contacts	Fine silver
Contact Configuration	Double-pole, double-break with electrically separated contact bridges
Contact Gap	2mm x 2mm
Contact Rating	4A (230VAC)
Switching Action	Slow-action, positive-break NC contacts
Short Circuit Protection	Fuse 6A (slow-blow)
Rated Insulation Voltage	250VAC
Rated Impulse Withstand	4kV
Type Terminals	Screw terminals with self-lifting clamps for up to 1.5mm ² (15AWG) flexible stranded wire

DIMENSIONS (mm)

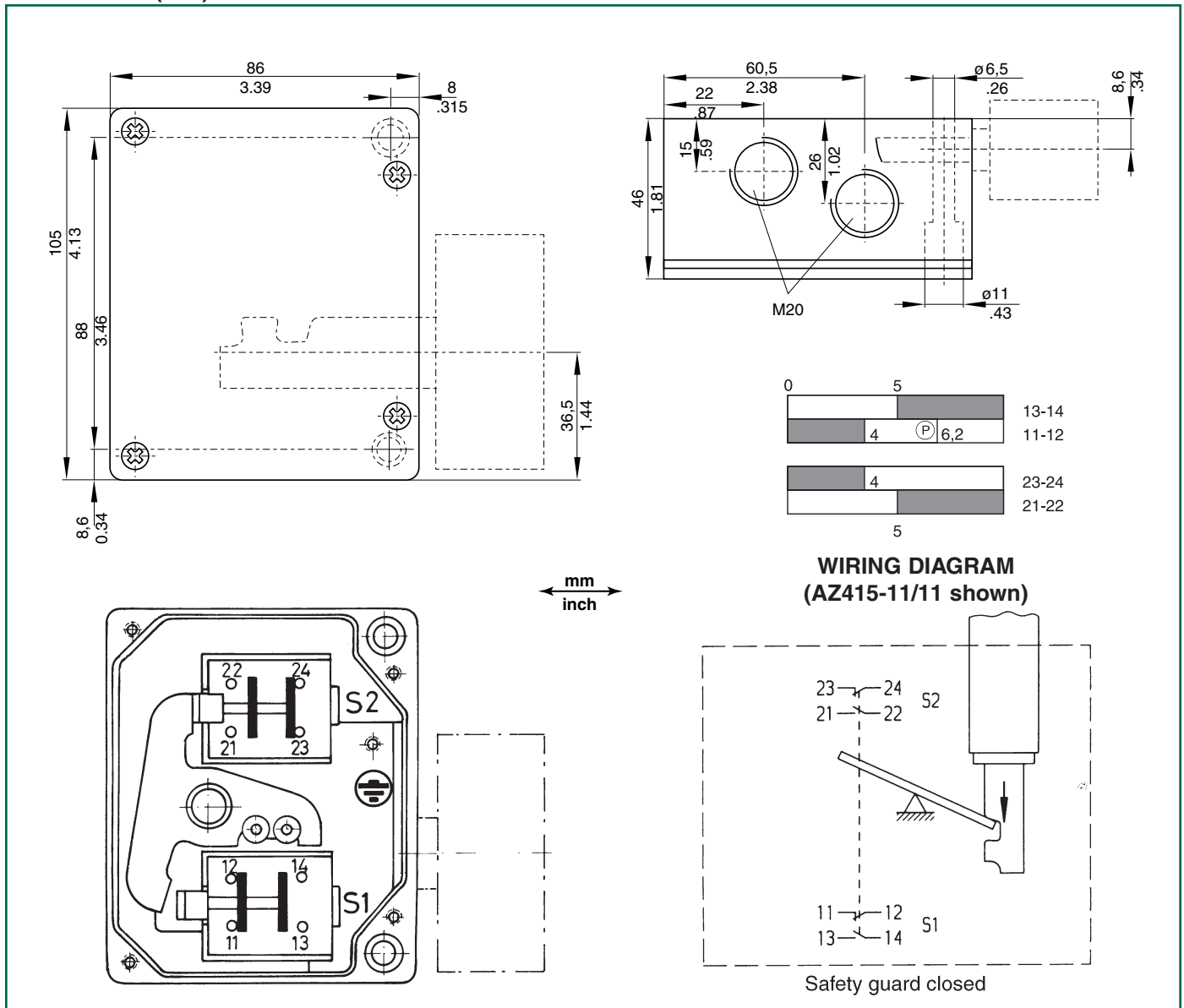

AZ415 TECHNICAL DATA

ACTUATOR KEY DIMENSIONS

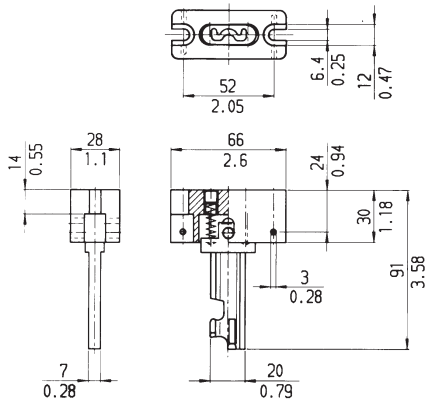

B2 Actuator

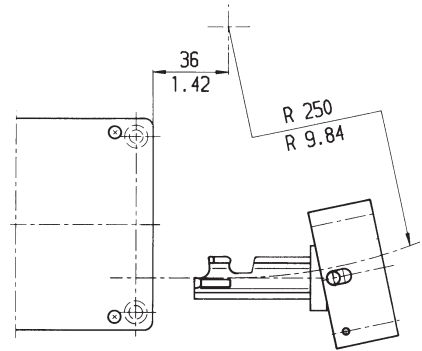
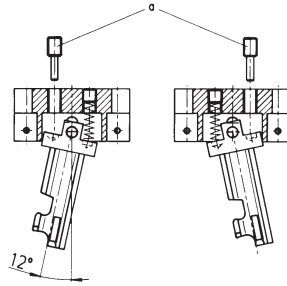

B2 Actuating radii
For hinged doors over the wide edge of the actuator

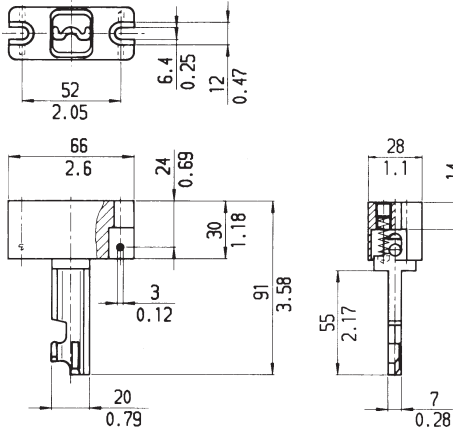

B3 Actuator

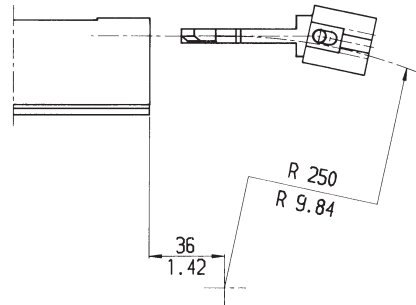
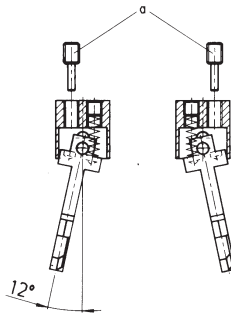

B3 Actuating radii
For hinged doors over the small edge of the actuator

Dowel holes are also provided in the actuator body. With the use of dowel pins the removal of the actuator can be prevented.

By turning the adjusting screw "a," the actuator can be brought into any desired position.

Both actuators can also be used on sliding doors.

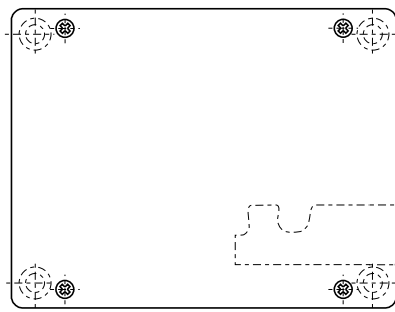

Recommended key clearance
greater than 3 mm

> 3 mm

AZ415 TECHNICAL DATA

ACTUATOR KEY DIMENSIONS

1

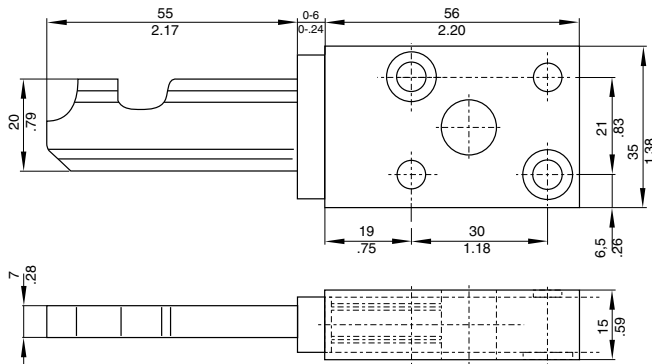

mm
inch

B1 Actuator

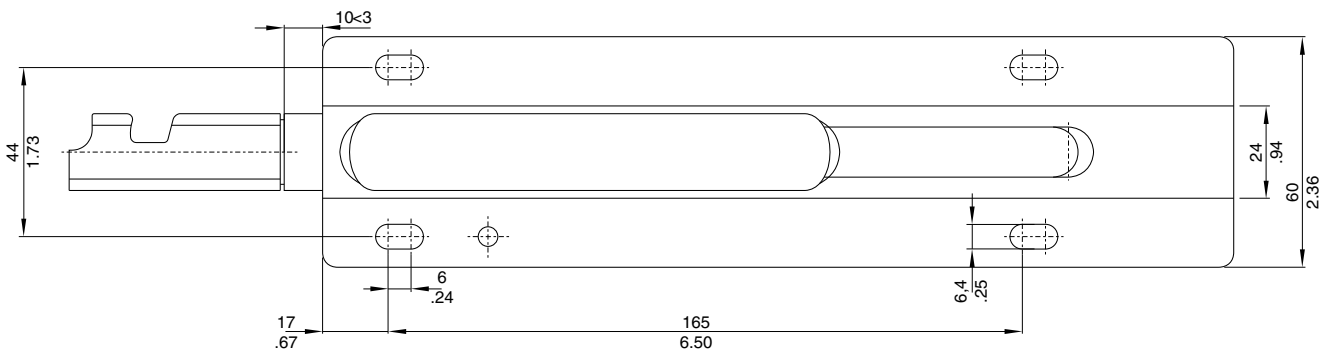
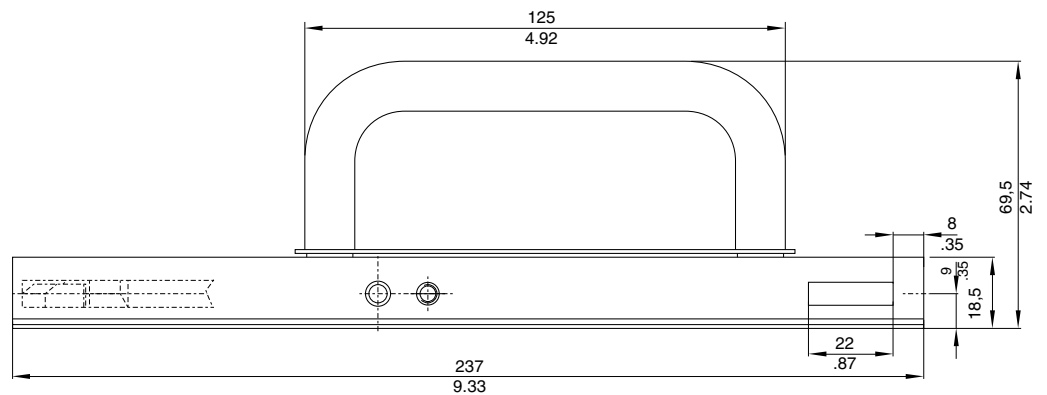

B4pS actuator for hand operated locking

Hand operated locking actuator

The hand operated lock bolt has the following advantages:

1. No further mechanical expenditures such as handles or levers are necessary.

2. The shearing forces on the actuator is 25,000 N (5,500 lbs.).

3. Simple installation of the unit.

4. Observing the actuating radius is not necessary.

5. An open guard door cannot fall shut and lock, causing the switch to be

actuated. The door must be manually closed and locked.

6. To insure personal safety when hazardous conditions are present, three holes are provided for padlocking which prevents the door from being locked.

41